



**THE DATASHEET OF  
SN65LBC174A16DWR**



# SNx5LBC174A Quadruple RS-485 Differential Line Drivers

## 1 Features

- Designed for TIA/EIA-485, TIA/EIA-422 and ISO 8482 applications
- Signaling Rates <sup>1</sup>up to 30 Mbps
- Propagation delay times < 11ns
- Low standby power consumption 1.5mA max
- Output ESD protection: 12kV
- Driver positive- and negative-current limiting
- Power-up and power-down glitch-free for line insertion applications
- Thermal shutdown protection
- Industry standard pin-out, compatible With SN75174, MC3487, DS96174, LTC487, and MAX3042

## 2 Applications

- [Motor drives](#)
- [Factory automation and control](#)

## 3 Description

The SN65LBC174A and SN75LBC174A are quadruple differential line drivers with 3-state outputs, designed for TIA/EIA-485 (RS-485), TIA/EIA-422 (RS-422), and ISO 8482 applications.

These devices are optimized for balanced multipoint bus transmission at signaling rates up to 30 million bits per second. The transmission media may be printed-circuit board traces, backplanes, or cables.

The ultimate rate and distance of data transfer is dependent upon the attenuation characteristics of the media and the noise coupling to the environment.

Each driver features current limiting and thermal-shutdown circuitry making it suitable for high-speed multipoint applications in noisy environments. These devices are designed using LinBiCMOS<sup>®</sup>, facilitating low power consumption and robustness.

The two EN inputs provide pair-wise driver enabling, or can be externally tied together to provide enable control of all four drivers with one signal. When disabled or powered off, the driver outputs present a high-impedance to the bus for reduced system loading.

The SN75LBC174A is characterized for operation over the temperature range of 0°C to 70°C. The SN65LBC174A is characterized for operation over the temperature range of -40°C to 85°C.

### Package Information

PART NUMBER	PACKAGE <sup>(1)</sup>	PACKAGE SIZE <sup>(2)</sup>
SN65LBC174A SN75LBC174A	SOIC (DW, 16)	10.3mm × 10.3mm
	SOIC (DW, 20)	12.8mm × 10.3mm
	PDIP (N, 16)	19.3mm × 9.4mm

(1) For more information, see [Section 11](#).

(2) The package size (length × width) is a nominal value and includes pins, where applicable.

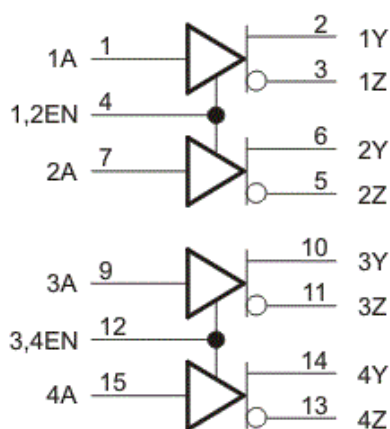

Logic Diagram (Positive Logic)

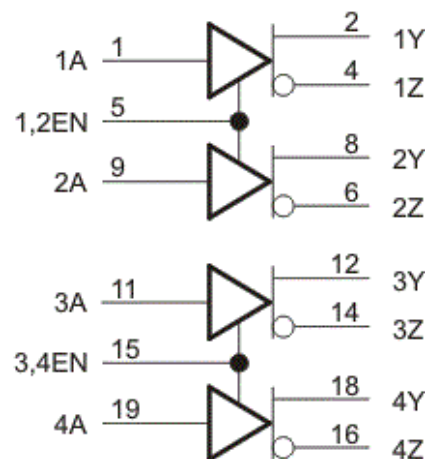

Logic Diagram (Positive Logic)

<sup>1</sup> The signaling rate of a line is the number of voltage transitions that are made per second expressed in the units bps (bits per second).



## Table of Contents

<b>1 Features</b> .....	<b>1</b>	<b>7 Device Functional Modes</b> .....	<b>13</b>
<b>2 Applications</b> .....	<b>1</b>	<b>8 Application and Implementation</b> .....	<b>14</b>
<b>3 Description</b> .....	<b>1</b>	8.1 Application Information.....	14
<b>4 Pin Configuration and Functions</b> .....	<b>3</b>	<b>9 Device and Documentation Support</b> .....	<b>15</b>
<b>5 Specifications</b> .....	<b>4</b>	9.1 Receiving Notification of Documentation Updates....	15
5.1 Absolute Maximum Ratings.....	4	9.2 Support Resources.....	15
5.2 Dissipation Rating Table.....	4	9.3 Trademarks.....	15
5.3 Recommended Operating Conditions.....	4	9.4 Electrostatic Discharge Caution.....	15
5.4 Thermal Information.....	5	9.5 Glossary.....	15
5.5 Electrical Characteristics.....	6	<b>10 Revision History</b> .....	<b>15</b>
5.6 Switching Characteristics.....	6	<b>11 Mechanical, Packaging, and Orderable</b>	
5.7 Typical Characteristics.....	7	<b>Information</b> .....	<b>16</b>
<b>6 Parameter Measure Information</b> .....	<b>8</b>		

## 4 Pin Configuration and Functions

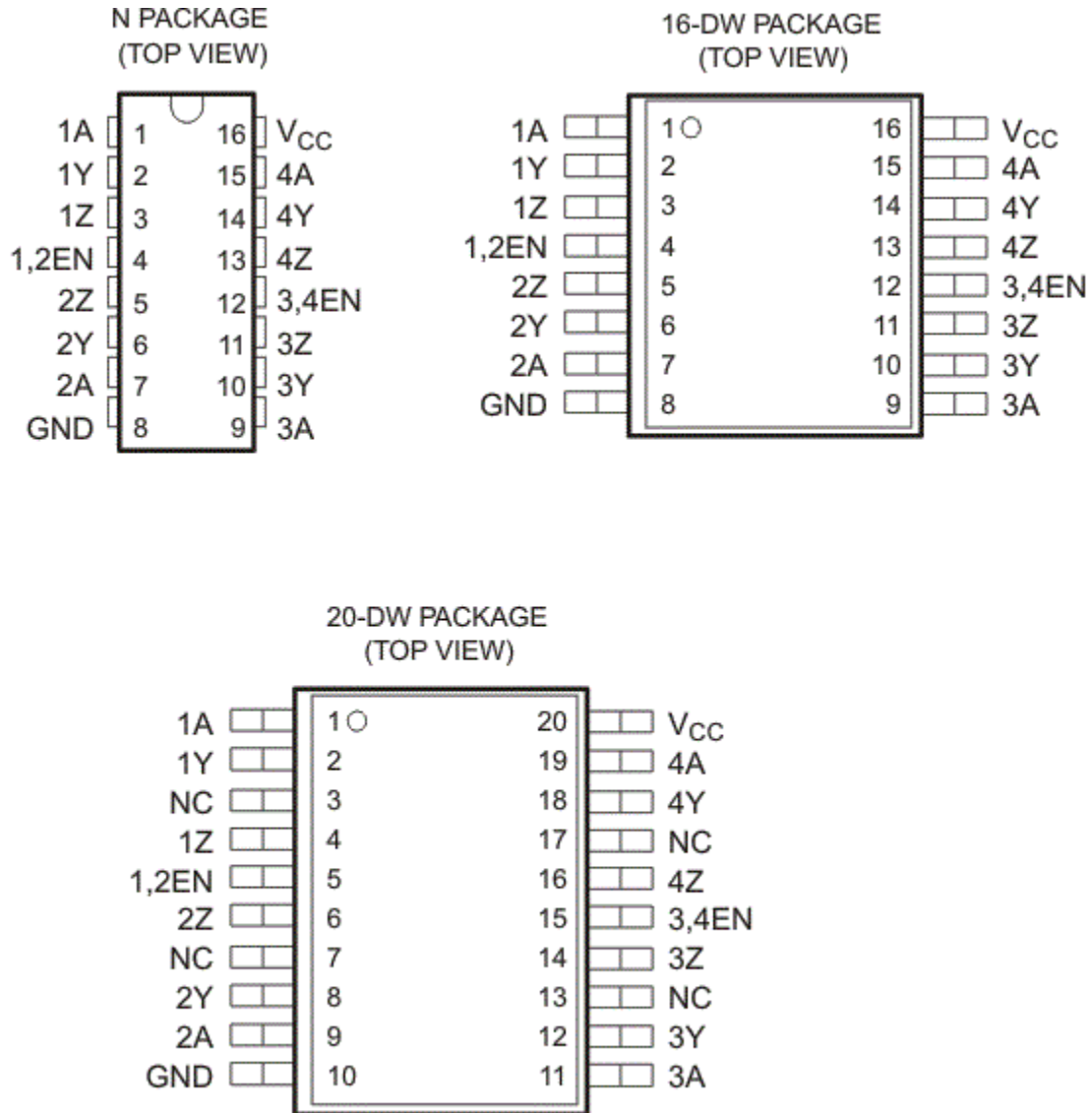

## 5 Specifications

### 5.1 Absolute Maximum Ratings

over operating free-air temperature range (unless otherwise noted)<sup>(1)</sup>

			VALUE / UNIT
Supply voltage range, $V_{CC}$ <sup>(2)</sup>			-0.3 V to 6 V
Voltage range at any bus (DC)			-10 V to 15 V
Voltage range at any bus (transient pulse through 100 $\Omega$ , see <a href="#">Figure 6-8</a> )			-30 V to 30 V
Input voltage range at any A or EN terminal, $V_I$			-0.5 V to $V_{CC} + 0.5$ V
Electrostatic discharge	Human body model <sup>(3)</sup>	Y, Z, and GND	$\pm 12$ kV
		All pins	$\pm 5$ kV
	Charged-device model <sup>(4)</sup>	All pins	$\pm 1$ kV
Storage temperature range, $T_{stg}$			-65°C to 150°C
Continuous power dissipation			See Dissipation Rating Table

- (1) Stresses beyond those listed under *Absolute Maximum Ratings* may cause permanent damage to the device. These are stress ratings only, and functional operation of the device at these or any other conditions beyond those indicated under *Recommended Operating Conditions* is not implied. Exposure to absolute-maximum-rated conditions for extended periods may affect device reliability.
- (2) All voltage values, except differential I/O bus voltages, are with respect to GND.
- (3) Tested in accordance with JEDEC standard 22, Test Method A114-A.
- (4) Tested in accordance with JEDEC standard 22, Test Method C101.

### 5.2 Dissipation Rating Table

**Table 5-1. Dissipation Rating Table**

PACKAGE <sup>(1)</sup>	JEDEC BOARD MODEL	$T_A \leq 25^\circ\text{C}$ POWER RATING	DERATING FACTOR ABOVE $T_A = 25^\circ\text{C}$ <sup>(2)</sup>	$T_A = 70^\circ\text{C}$ POWER RATING	$T_A = 85^\circ\text{C}$ POWER RATING
16 DW	LOW K	1200 mW	9.6 mW/°C	769 mW	625 mW
	HIGH K	2240 mW	17.9 mW/°C	1434 mW	1165 mW
20 DW	LOW K	1483 mW	11.86 mW/°C	949 mW	771 mW
	HIGH K	2753 mW	22 mW/°C	1762 mW	1432 mW
16 N	LOW K	1150 mW	9.2 mW/°C	736 mW	598 mW

- (1) For the most current package and ordering information, see the Package Option Addendum at the end of this document, or see the TI website at [www.ti.com](http://www.ti.com).
- (2) This is the inverse of the junction-to-ambient thermal resistance when board-mounted and with no air flow.

### 5.3 Recommended Operating Conditions

		MIN	NOM	MAX	UNIT
Supply voltage, $V_{CC}$		4.75	5	5.25	V
Voltage at any bus terminal	Y, Z	-7		12	V
High-level input voltage, $V_{IH}$	A, EN	2		$V_{CC}$	V
Low-level input voltage, $V_{IL}$		0		0.8	
Output current		-60		60	mA
Operating free-air temperature, $T_A$	SN75LBC174A	0		70	°C
	SN65LBC174A	-40		85	

## 5.4 Thermal Information

THERMAL METRIC <sup>(1)</sup>		SN75ALS174A			UNIT
		N (PDIP)	DW (SOIC)	DW	
		16 PINS	16 PINS	20 PINS	
$R_{\theta JA}$	Junction-to-ambient thermal resistance	60.6	71.1	66.8	°C/W
$R_{\theta JC(top)}$	Junction-to-case (top) thermal resistance	48.1	37.4	34.4	°C/W
$R_{\theta JB}$	Junction-to-board thermal resistance	40.6	36.8	39.7	°C/W
$\psi_{JT}$	Junction-to-top characterization parameter	27.5	13.3	8.9	°C/W
$\psi_{JB}$	Junction-to-board characterization parameter	40.3	36.4	39	°C/W
$R_{\theta JC(bot)}$	Junction-to-case (bottom) thermal resistance	n/a	n/a	n/a	°C/W

- (1) For more information about traditional and new thermal metrics, see the [Semiconductor and IC Package Thermal Metrics](#) application report.

## 5.5 Electrical Characteristics

over recommended operating conditions

PARAMETER		TEST CONDITIONS	MIN	TYP <sup>(1)</sup>	MAX	UNIT
V <sub>IK</sub>	Input clamp voltage	I <sub>I</sub> = -18 mA	-1.5	-0.77		V
V <sub>O</sub>	Open-circuit output voltage	Y or Z, No load	0		V <sub>CC</sub>	V
V <sub>OD(SS)</sub>	Steady-state differential output voltage magnitude <sup>(2)</sup>	No load (open circuit)	3		V <sub>CC</sub>	V
		R <sub>L</sub> = 54Ω, See Figure 6-1	1	1.6	2.5	
		With common-mode loading, See Figure 6-2	1	1.6	2.5	
ΔV <sub>OD(SS)</sub>	Change in steady-state differential output voltage between logic states	See Figure 6-1	-0.1		0.1	V
V <sub>OC(SS)</sub>	Steady-state common-mode output voltage	See Figure 6-3	2	2.4	2.8	V
ΔV <sub>OC(SS)</sub>	Change in steady-state common-mode output voltage between logic states	See Figure 6-3	-0.02		0.02	V
I <sub>I</sub>	Input current	A, EN	-50		50	μA
I <sub>OS</sub>	Short-circuit output current	V <sub>TEST</sub> = -7V to 12V, See Figure 6-7	-200		200	mA
I <sub>OZ</sub>	High-impedance-state output current					
I <sub>O(OFF)</sub>	Output current with power off	V <sub>CC</sub> = 0V	-10		10	μA
I <sub>CC</sub>	Supply current	V <sub>I</sub> = 0V or V <sub>CC</sub> , No load	All drivers enabled		23	mA
			All drivers disabled		1.5	
C <sub>IN</sub>	Input Capacitance	A inputs		13		pF
		EN inputs		21		pF

(1) All typical values are at V<sub>CC</sub> = 5V and 25°C.

(2) The minimum V<sub>OD</sub> may not fully comply with TIA/EIA-485-A at operating temperatures below 0°C. System designers should take the possibly lower output signal into account in determining the maximum signal transmission distance.

## 5.6 Switching Characteristics

over recommended operating conditions

PARAMETER	TEST CONDITIONS	MIN	TYP	MAX	UNIT	
t <sub>PLH</sub>	Propagation delay time, low-to-high level output	5.5	8	11	ns	
t <sub>PHL</sub>	Propagation delay time, high-to-low level output	5.5	8	11	ns	
t <sub>r</sub>	Differential output voltage rise time	2	7.5	11	ns	
t <sub>f</sub>	Differential output voltage fall time	2	7.5	11	ns	
t <sub>sk(p)</sub>	Pulse skew  t <sub>PLH</sub> - t <sub>PHL</sub>	R <sub>L</sub> = 54Ω, C <sub>L</sub> = 50pF, See Figure 6-4		0.6	2	ns
				0.6	2	
t <sub>sk(o)</sub>	Output skew <sup>(1)</sup>			2	ns	
t <sub>sk(pp)</sub>	Part-to-part skew <sup>(2)</sup>			3	ns	
t <sub>PZH</sub>	Propagation delay time, high-impedance-to-high-level output	See Figure 6-5		25	ns	
t <sub>PHZ</sub>	Propagation delay time, high-level-output-to-high impedance			25	ns	
t <sub>PZL</sub>	Propagation delay time, high-impedance-to-low-level output	See Figure 6-6		30	ns	
t <sub>PLZ</sub>	Propagation delay time, low-level-output-to-high impedance			20	ns	

(1) Output skew (t<sub>sk(o)</sub>) is the magnitude of the time delay difference between the outputs of a single device with all of the inputs connected together.

(2) Part-to-part skew (t<sub>sk(pp)</sub>) is the magnitude of the difference in propagation delay times between any specified terminals of two devices when both devices operate with the same input signals, the same supply voltages, at the same temperature, and have identical packages and test circuits.

### 5.7 Typical Characteristics

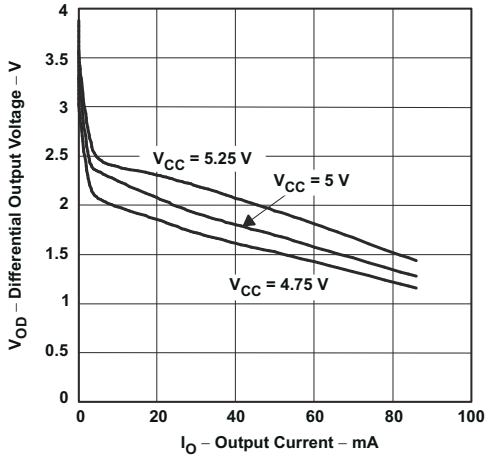

Figure 5-1. Differential Output Voltage vs Output Current

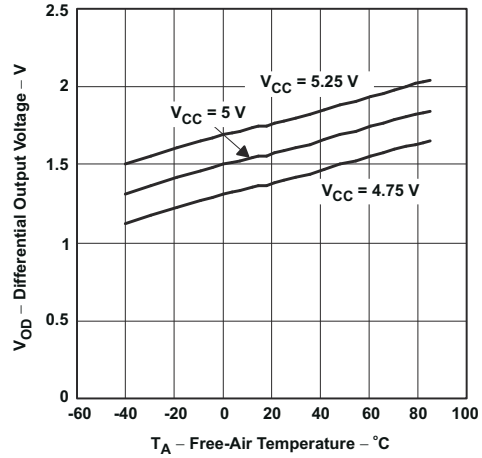

Figure 5-2. Differential Output Voltage vs Free-air Temperature

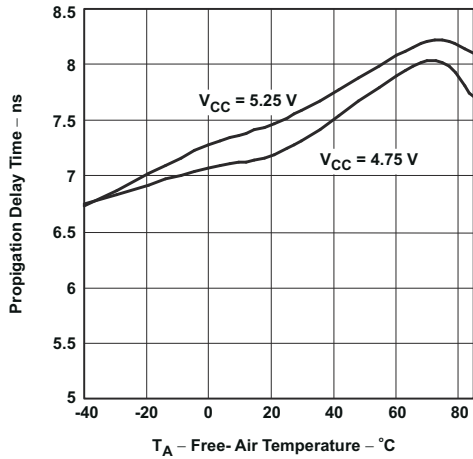

Figure 5-3. Propagation Delay Time vs Free-air Temperature

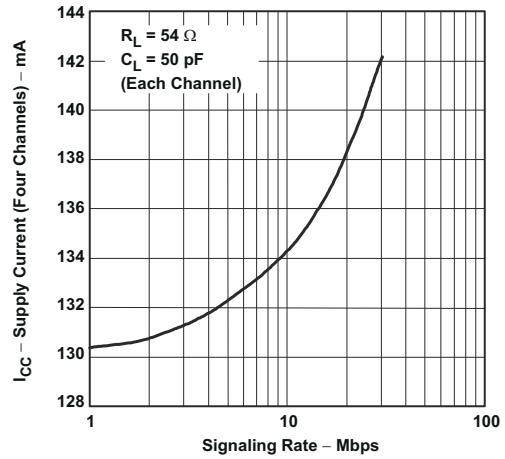

Figure 5-4. Supply Current (Four Channels) vs Signaling Rate

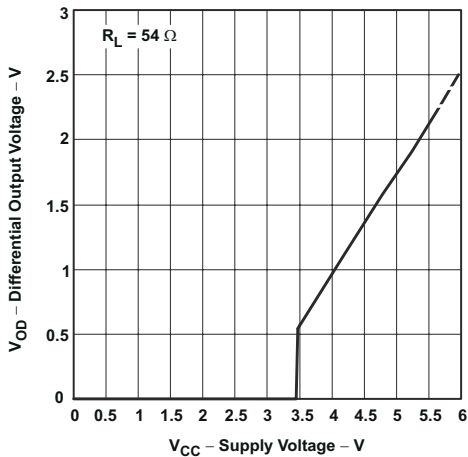

Figure 5-5. Differential Output Voltage vs Supply Voltage

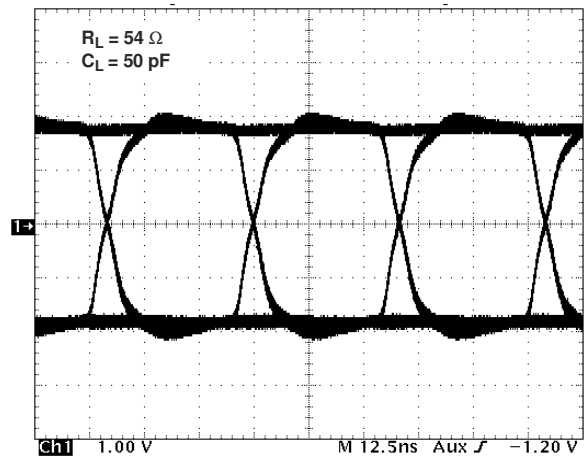
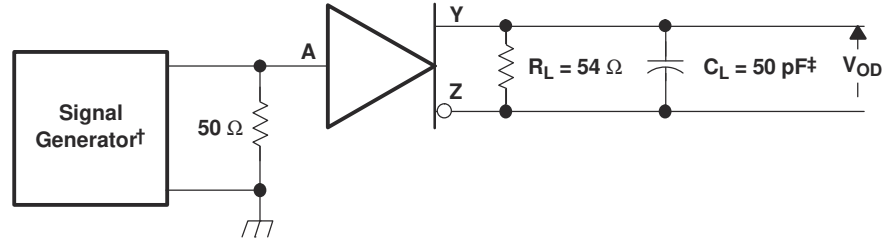
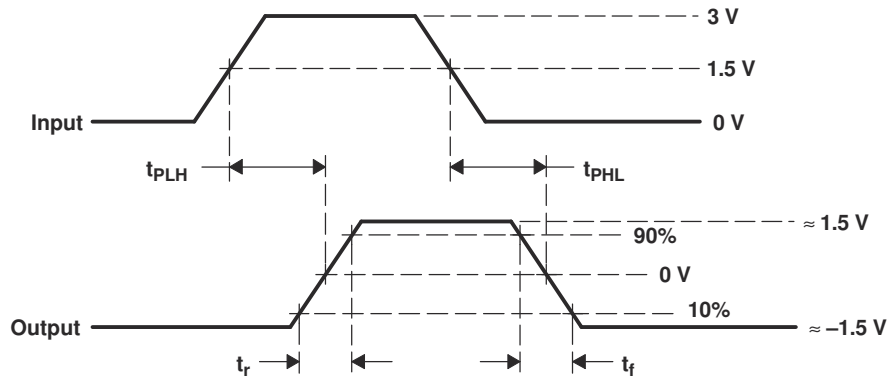

Figure 5-6. Eye Pattern, Pseudorandom Data at +30Mbps





† PRR = 1 MHz, 50% Duty Cycle,  $t_r < 6$  ns,  $t_f < 6$  ns,  $Z_O = 50 \Omega$   
 ‡ Includes probe and jig capacitance



**Figure 6-4. Output Switching Test Circuit and Waveforms**

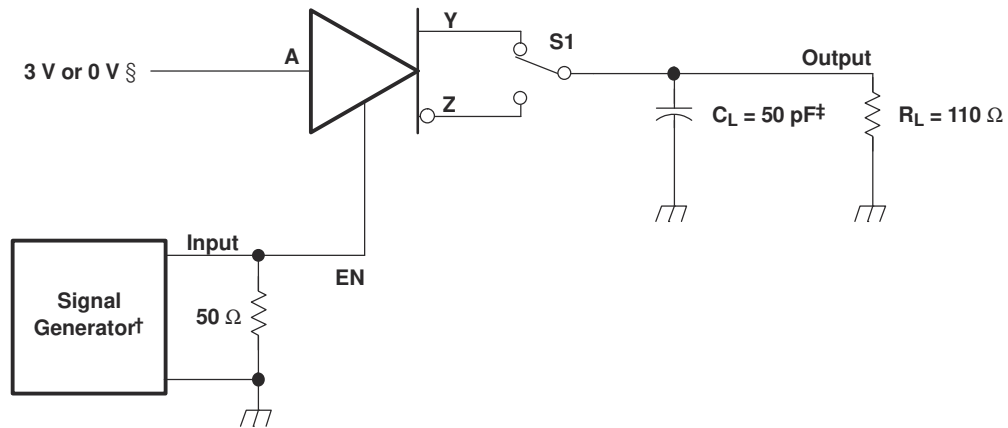

† PRR = 1 MHz, 50% Duty Cycle,  $t_r < 6$  ns,  $t_f < 6$  ns,  $Z_O = 50 \Omega$

‡ Includes probe and jig capacitance

§ 3 V if testing Y output, 0 V if testing Z output

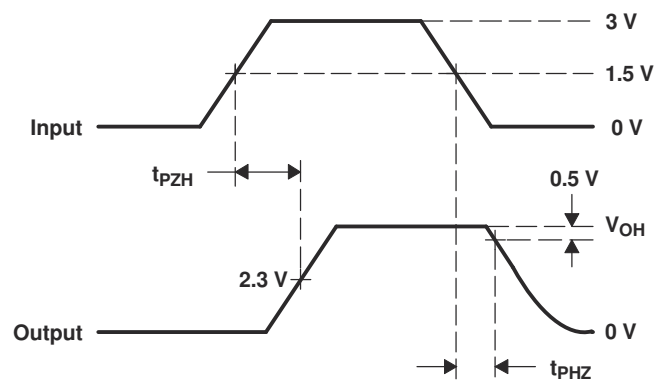
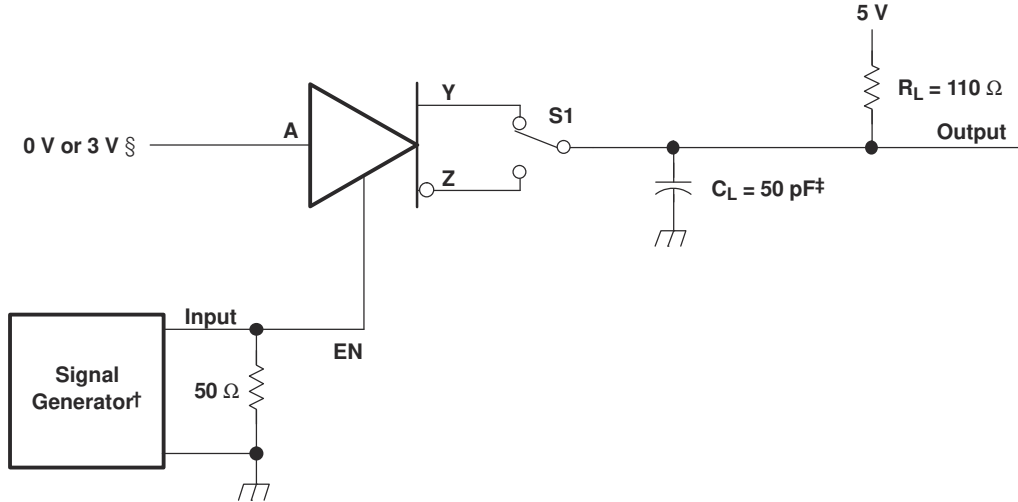
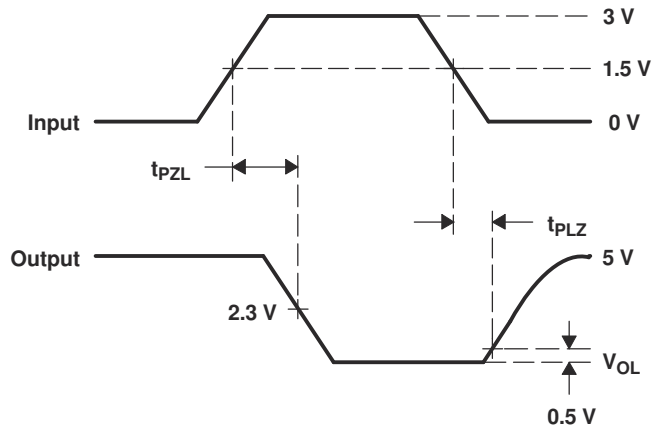

Figure 6-5. Enable Timing Test Circuit and Waveforms,  $t_{pZH}$  and  $t_{pHZ}$



† PRR = 1 MHz, 50% Duty Cycle,  $t_r < 6$  ns,  $t_f < 6$  ns,  $Z_O = 50 \Omega$   
 ‡ Includes probe and jig capacitance  
 § 3 V if testing Y output, 0 V if testing Z output



**Figure 6-6. Enable Timing Test Circuit and Waveforms,  $t_{pZL}$  and  $t_{pLZ}$**

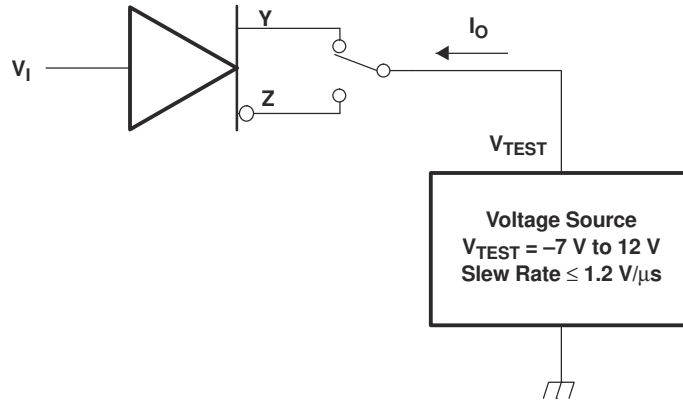

Figure 6-7. Test Circuit, Short-Circuit Output Current

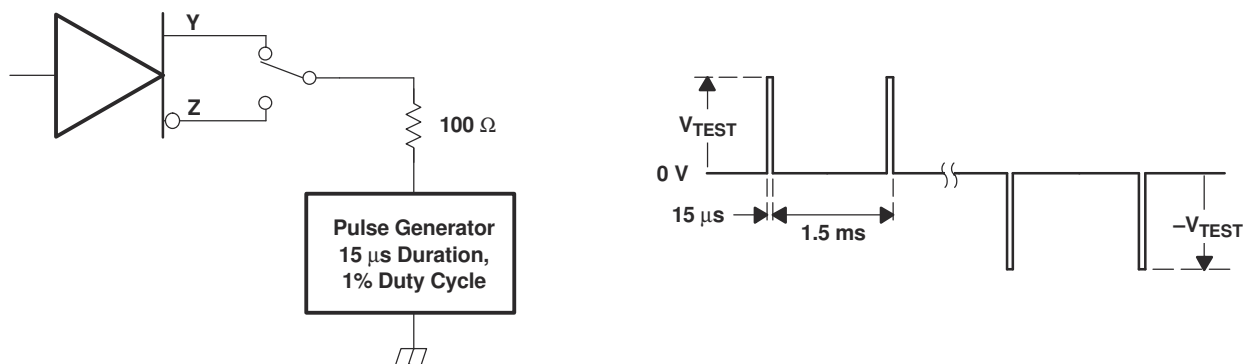

Figure 6-8. Test Circuit Waveform, Transient Overvoltage Test

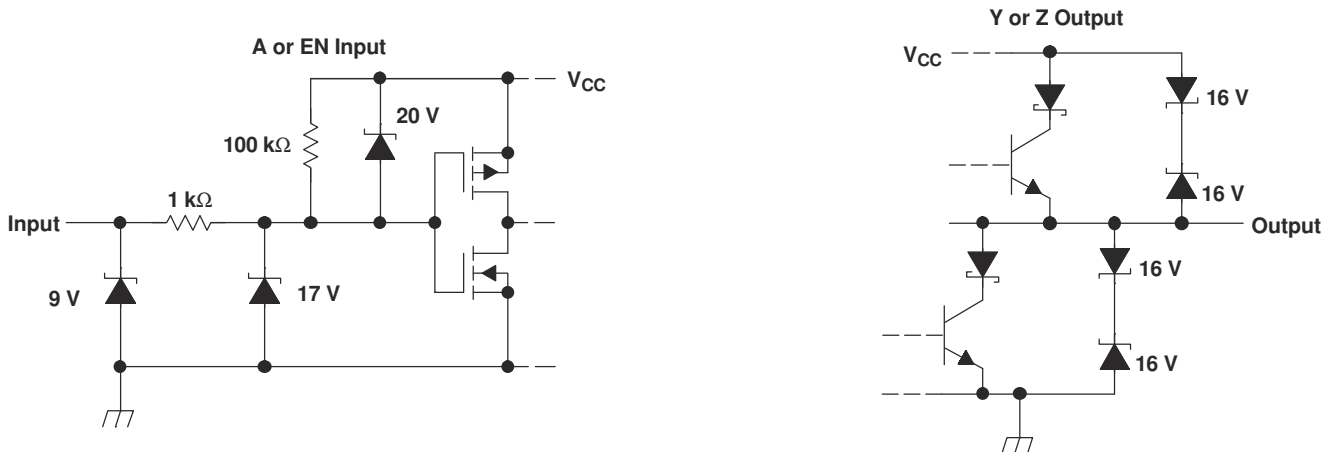

Figure 6-9. Equivalent Input and Output Schematic Diagrams

## 7 Device Functional Modes

**Table 7-1. Function table (each driver)**

INPUT <sup>(1)</sup>	ENABLE	OUTPUT	OUTPUT
A	EN	Y	Z
L	H	L	H
H	H	H	L
OPEN	H	H	L
L	OPEN	L	H
H	OPEN	H	L
OPEN	OPEN	H	L
X	L	Z	Z

(1) H = high level, L = low level, X = irrelevant, Z = high impedance (off)

## 8 Application and Implementation

### Note

Information in the following applications sections is not part of the TI component specification, and TI does not warrant its accuracy or completeness. TI's customers are responsible for determining suitability of components for their purposes, as well as validating and testing their design implementation to confirm system functionality.

### 8.1 Application Information

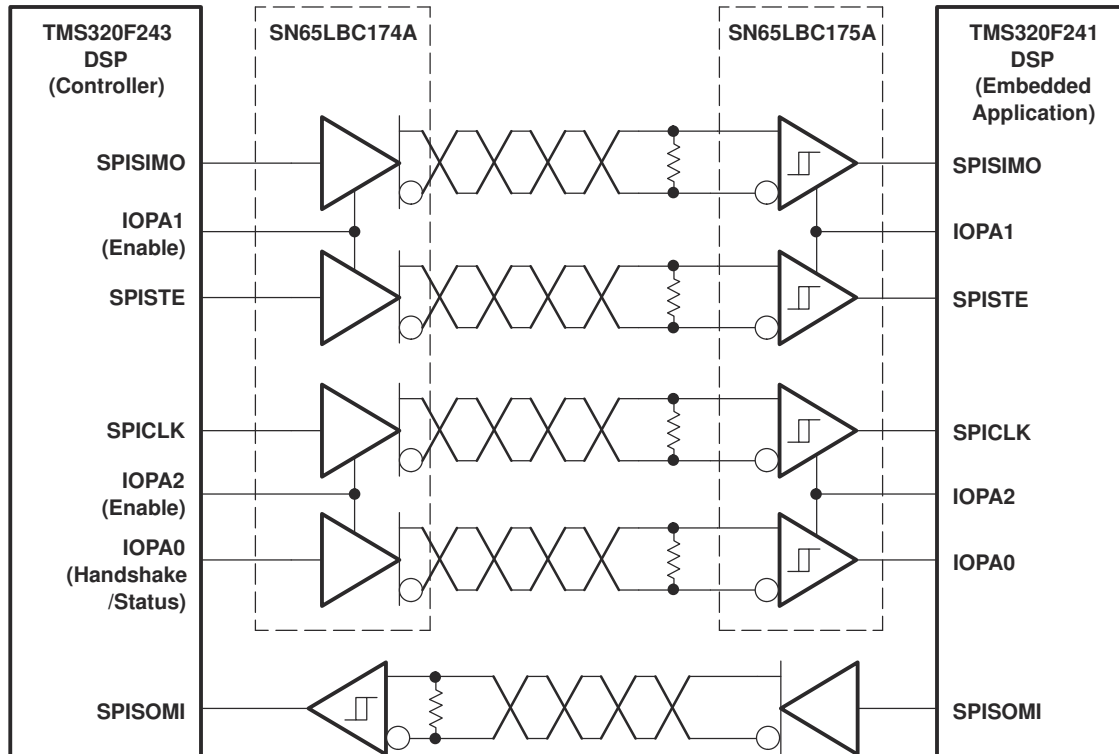

Figure 8-1. Typical Application Circuit, DSP-to-DSP Link via Serial Peripheral Interface

## 9 Device and Documentation Support

TI offers an extensive line of development tools. Tools and software to evaluate the performance of the device, generate code, and develop solutions are listed below.

### 9.1 Receiving Notification of Documentation Updates

To receive notification of documentation updates, navigate to the device product folder on [ti.com](http://ti.com). Click on *Notifications* to register and receive a weekly digest of any product information that has changed. For change details, review the revision history included in any revised document.

### 9.2 Support Resources

[TI E2E™ support forums](#) are an engineer's go-to source for fast, verified answers and design help — straight from the experts. Search existing answers or ask your own question to get the quick design help you need.

Linked content is provided "AS IS" by the respective contributors. They do not constitute TI specifications and do not necessarily reflect TI's views; see TI's [Terms of Use](#).

### 9.3 Trademarks

TI E2E™ is a trademark of Texas Instruments.

LinBiCMOS® is a registered trademark of Texas Instruments.

All trademarks are the property of their respective owners.

### 9.4 Electrostatic Discharge Caution



This integrated circuit can be damaged by ESD. Texas Instruments recommends that all integrated circuits be handled with appropriate precautions. Failure to observe proper handling and installation procedures can cause damage.

ESD damage can range from subtle performance degradation to complete device failure. Precision integrated circuits may be more susceptible to damage because very small parametric changes could cause the device not to meet its published specifications.

### 9.5 Glossary

[TI Glossary](#) This glossary lists and explains terms, acronyms, and definitions.

## 10 Revision History

NOTE: Page numbers for previous revisions may differ from page numbers in the current version.

### Changes from Revision F (October 2009) to Revision G (April 2024) Page

- Changed the numbering format for tables, figures, and cross-references throughout the document..... 1
- Added the *Thermal Information* table..... 5

### Changes from Revision E (July 2008) to Revision F (October 2009) Page

- Added C<sub>IN</sub> - Input Capacitance to the Electrical Characteristics table..... 6
- Changed the location of [Figure 6-9](#) ..... 8
- Changed [Table 7-1](#) header From: ENABLE G To: ENABLE EN..... 13

### Changes from Revision D (June 2008) to Revision E (July 2008) Page

- Changed Features bullet From: Output ESD Protection Exceeds 11 kV To: Output ESD Protection: 12 kV..... 1
- Changed Electrostatic discharge-Human body model-Y, Z, and GND From: 11kV To: 12kV..... 4
- From: A, G,  $\bar{G}$  To: A, EN..... 6

---

<b>Changes from Revision C (June 2008) to Revision D (July 2008)</b>	<b>Page</b>
• Changed Electrostatic discharge-Human body model-Y, Z, and GND From: 13kV To: 11kV.....	4
• Changed the <i>Dissipation Rating Table</i> .....	4

---

<b>Changes from Revision B (June 2001) to Revision C (May 2003)</b>	<b>Page</b>
• Changed Features bullet From: Output ESD Protection Exceeds 13 kV To: Output ESD Protection: 11 kV.....	1
• Changed Features bullet for Industry Standard From: Compatible With SN75174, MC3487, and DS96174 To: Compatible With SN75174, MC3487, DS96174, LTC487, and MAX3042.....	1

---

<b>Changes from Revision A (February 2001) to Revision B (June 2001)</b>	<b>Page</b>
• Changed DW Package appearance.....	3
• Added <a href="#">Figure 5-5</a> .....	7

---

<b>Changes from Revision * (October 2000) to Revision A (February 2001)</b>	<b>Page</b>
• Changed multiple items throughout the data sheet.....	1

---

## 11 Mechanical, Packaging, and Orderable Information

The following pages include mechanical, packaging, and orderable information. This information is the most current data available for the designated devices. This data is subject to change without notice and revision of this document. For browser-based versions of this data sheet, refer to the left-hand navigation.

**PACKAGING INFORMATION**

Orderable Device	Status (1)	Package Type	Package Drawing	Pins	Package Qty	Eco Plan (2)	Lead finish/ Ball material (6)	MSL Peak Temp (3)	Op Temp (°C)	Device Marking (4/5)	Samples
SN65LBC174A16DW	LIFEBUY	SOIC	DW	16	40	RoHS & Green	NIPDAU	Level-1-260C-UNLIM	-40 to 85	65LBC174A	
SN65LBC174A16DWR	ACTIVE	SOIC	DW	16	2000	RoHS & Green	NIPDAU	Level-1-260C-UNLIM	-40 to 85	65LBC174A	Samples
SN65LBC174A16DWRG4	ACTIVE	SOIC	DW	16	2000	RoHS & Green	NIPDAU	Level-1-260C-UNLIM	-40 to 85	65LBC174A	Samples
SN65LBC174ADW	LIFEBUY	SOIC	DW	20	25	RoHS & Green	NIPDAU	Level-1-260C-UNLIM	-40 to 85	65LBC174A	
SN65LBC174ADWR	ACTIVE	SOIC	DW	20	2000	RoHS & Green	NIPDAU	Level-1-260C-UNLIM	-40 to 85	65LBC174A	Samples
SN65LBC174AN	ACTIVE	PDIP	N	16	25	RoHS & Green	NIPDAU	N / A for Pkg Type	-40 to 85	65LBC174A	Samples
SN75LBC174A16DW	LIFEBUY	SOIC	DW	16	40	RoHS & Green	NIPDAU	Level-1-260C-UNLIM	0 to 70	75LBC174A	
SN75LBC174A16DWR	LIFEBUY	SOIC	DW	16	2000	RoHS & Green	NIPDAU	Level-1-260C-UNLIM	0 to 70	75LBC174A	
SN75LBC174ADW	ACTIVE	SOIC	DW	20	25	RoHS & Green	NIPDAU	Level-1-260C-UNLIM	0 to 70	75LBC174A	Samples
SN75LBC174ADWR	ACTIVE	SOIC	DW	20	2000	RoHS & Green	NIPDAU	Level-1-260C-UNLIM	0 to 70	75LBC174A	Samples
SN75LBC174AN	LIFEBUY	PDIP	N	16	25	RoHS & Green	NIPDAU	N / A for Pkg Type	0 to 70	75LBC174A	

(1) The marketing status values are defined as follows:

**ACTIVE:** Product device recommended for new designs.

**LIFEBUY:** TI has announced that the device will be discontinued, and a lifetime-buy period is in effect.

**NRND:** Not recommended for new designs. Device is in production to support existing customers, but TI does not recommend using this part in a new design.

**PREVIEW:** Device has been announced but is not in production. Samples may or may not be available.

**OBSELETE:** TI has discontinued the production of the device.

(2) **RoHS:** TI defines "RoHS" to mean semiconductor products that are compliant with the current EU RoHS requirements for all 10 RoHS substances, including the requirement that RoHS substance do not exceed 0.1% by weight in homogeneous materials. Where designed to be soldered at high temperatures, "RoHS" products are suitable for use in specified lead-free processes. TI may reference these types of products as "Pb-Free".

**RoHS Exempt:** TI defines "RoHS Exempt" to mean products that contain lead but are compliant with EU RoHS pursuant to a specific EU RoHS exemption.

**Green:** TI defines "Green" to mean the content of Chlorine (Cl) and Bromine (Br) based flame retardants meet JS709B low halogen requirements of <=1000ppm threshold. Antimony trioxide based flame retardants must also meet the <=1000ppm threshold requirement.

(3) MSL, Peak Temp. - The Moisture Sensitivity Level rating according to the JEDEC industry standard classifications, and peak solder temperature.

(4) There may be additional marking, which relates to the logo, the lot trace code information, or the environmental category on the device.

(5) Multiple Device Markings will be inside parentheses. Only one Device Marking contained in parentheses and separated by a "~" will appear on a device. If a line is indented then it is a continuation of the previous line and the two combined represent the entire Device Marking for that device.

(6) Lead finish/Ball material - Orderable Devices may have multiple material finish options. Finish options are separated by a vertical ruled line. Lead finish/Ball material values may wrap to two lines if the finish value exceeds the maximum column width.

**Important Information and Disclaimer:**The information provided on this page represents TI's knowledge and belief as of the date that it is provided. TI bases its knowledge and belief on information provided by third parties, and makes no representation or warranty as to the accuracy of such information. Efforts are underway to better integrate information from third parties. TI has taken and continues to take reasonable steps to provide representative and accurate information but may not have conducted destructive testing or chemical analysis on incoming materials and chemicals. TI and TI suppliers consider certain information to be proprietary, and thus CAS numbers and other limited information may not be available for release.

In no event shall TI's liability arising out of such information exceed the total purchase price of the TI part(s) at issue in this document sold by TI to Customer on an annual basis.

**OTHER QUALIFIED VERSIONS OF SN65LBC174A :**

- Enhanced Product : [SN65LBC174A-EP](#)

NOTE: Qualified Version Definitions:

- Enhanced Product - Supports Defense, Aerospace and Medical Applications

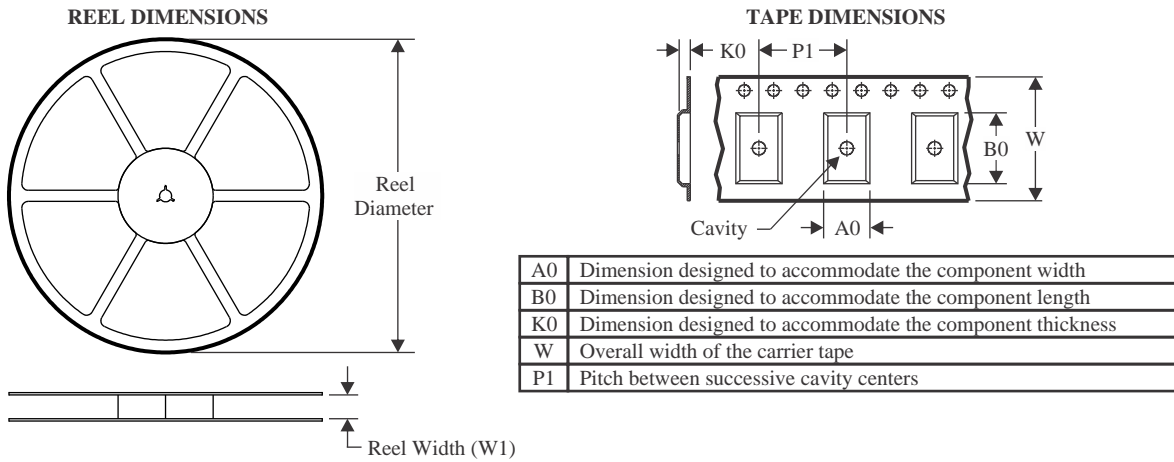
**TAPE AND REEL INFORMATION**

**QUADRANT ASSIGNMENTS FOR PIN 1 ORIENTATION IN TAPE**

\*All dimensions are nominal

Device	Package Type	Package Drawing	Pins	SPQ	Reel Diameter (mm)	Reel Width W1 (mm)	A0 (mm)	B0 (mm)	K0 (mm)	P1 (mm)	W (mm)	Pin1 Quadrant
SN65LBC174A16DWR	SOIC	DW	16	2000	330.0	16.4	10.75	10.7	2.7	12.0	16.0	Q1
SN65LBC174ADWR	SOIC	DW	20	2000	330.0	24.4	10.8	13.3	2.7	12.0	24.0	Q1
SN75LBC174A16DWR	SOIC	DW	16	2000	330.0	16.4	10.75	10.7	2.7	12.0	16.0	Q1
SN75LBC174ADWR	SOIC	DW	20	2000	330.0	24.4	10.8	13.3	2.7	12.0	24.0	Q1

## TAPE AND REEL BOX DIMENSIONS



\*All dimensions are nominal

Device	Package Type	Package Drawing	Pins	SPQ	Length (mm)	Width (mm)	Height (mm)
SN65LBC174A16DWR	SOIC	DW	16	2000	350.0	350.0	43.0
SN65LBC174ADWR	SOIC	DW	20	2000	367.0	367.0	45.0
SN75LBC174A16DWR	SOIC	DW	16	2000	350.0	350.0	43.0
SN75LBC174ADWR	SOIC	DW	20	2000	350.0	350.0	43.0

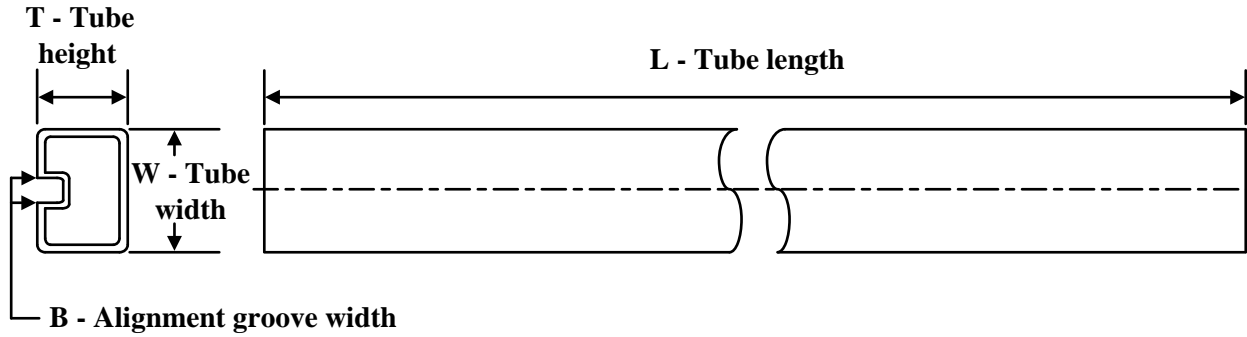
**TUBE**

\*All dimensions are nominal

Device	Package Name	Package Type	Pins	SPQ	L (mm)	W (mm)	T (μm)	B (mm)
SN65LBC174A16DW	DW	SOIC	16	40	506.98	12.7	4826	6.6
SN65LBC174ADW	DW	SOIC	20	25	507	12.83	5080	6.6
SN65LBC174ADW	DW	SOIC	20	25	506.98	12.7	4826	6.6
SN65LBC174AN	N	PDIP	16	25	506	13.97	11230	4.32
SN75LBC174A16DW	DW	SOIC	16	40	506.98	12.7	4826	6.6
SN75LBC174ADW	DW	SOIC	20	25	507	12.83	5080	6.6
SN75LBC174ADW	DW	SOIC	20	25	506.98	12.7	4826	6.6
SN75LBC174AN	N	PDIP	16	25	506	13.97	11230	4.32

## GENERIC PACKAGE VIEW

**DW 16**

**SOIC - 2.65 mm max height**

7.5 x 10.3, 1.27 mm pitch

SMALL OUTLINE INTEGRATED CIRCUIT

This image is a representation of the package family, actual package may vary.  
Refer to the product data sheet for package details.



4224780/A



# DW0016A

# PACKAGE OUTLINE SOIC - 2.65 mm max height

SOIC

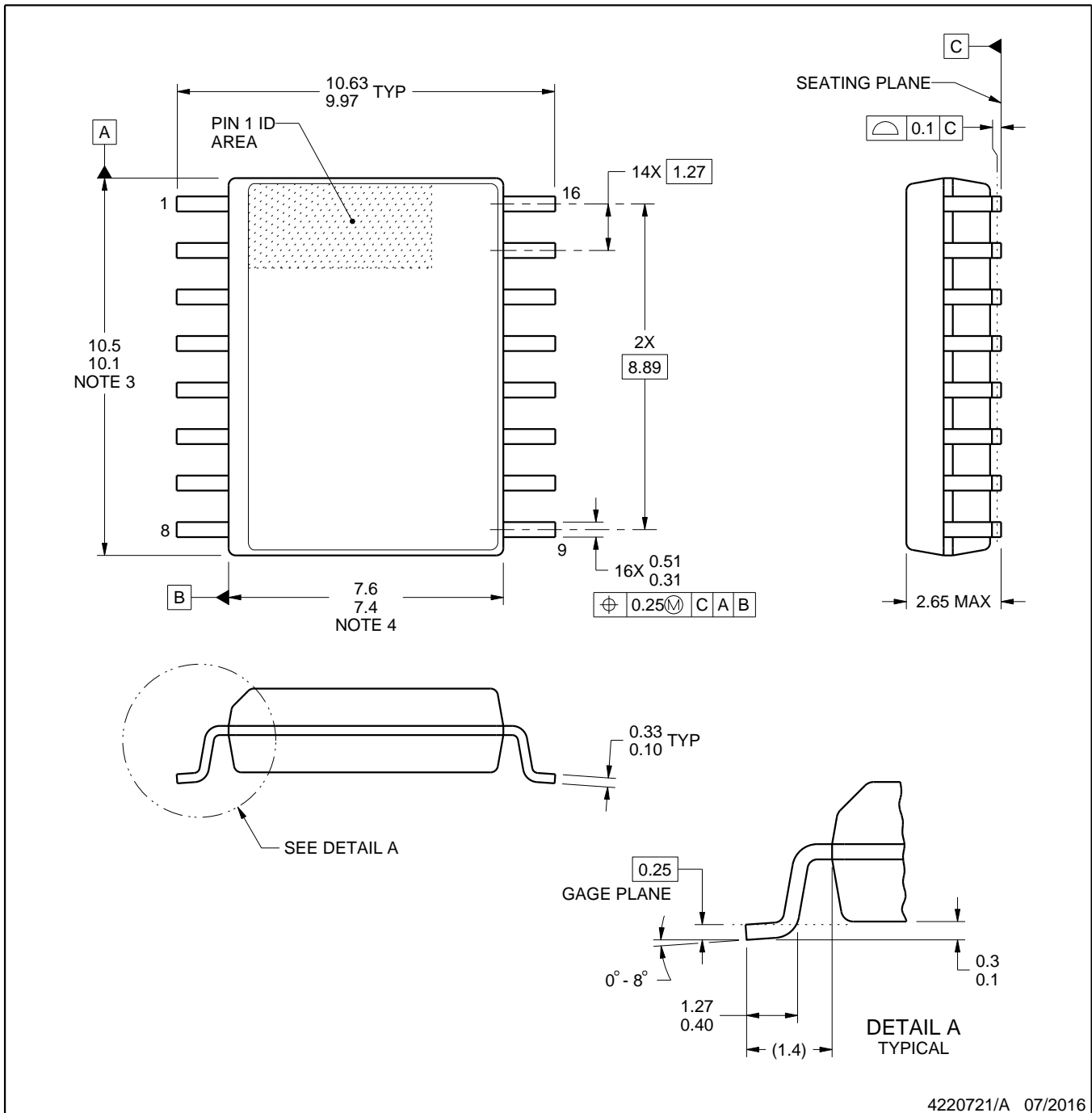

4220721/A 07/2016

## NOTES:

1. All linear dimensions are in millimeters. Dimensions in parenthesis are for reference only. Dimensioning and tolerancing per ASME Y14.5M.
2. This drawing is subject to change without notice.
3. This dimension does not include mold flash, protrusions, or gate burrs. Mold flash, protrusions, or gate burrs shall not exceed 0.15 mm, per side.
4. This dimension does not include interlead flash. Interlead flash shall not exceed 0.25 mm, per side.
5. Reference JEDEC registration MS-013.

# EXAMPLE BOARD LAYOUT

DW0016A

SOIC - 2.65 mm max height

SOIC



LAND PATTERN EXAMPLE  
SCALE:7X



SOLDER MASK DETAILS

4220721/A 07/2016

NOTES: (continued)

6. Publication IPC-7351 may have alternate designs.

7. Solder mask tolerances between and around signal pads can vary based on board fabrication site.

# EXAMPLE STENCIL DESIGN

DW0016A

SOIC - 2.65 mm max height

SOIC



SOLDER PASTE EXAMPLE  
BASED ON 0.125 mm THICK STENCIL  
SCALE:7X

4220721/A 07/2016

NOTES: (continued)

8. Laser cutting apertures with trapezoidal walls and rounded corners may offer better paste release. IPC-7525 may have alternate design recommendations.
9. Board assembly site may have different recommendations for stencil design.

N (R-PDIP-T\*\*)

PLASTIC DUAL-IN-LINE PACKAGE

16 PINS SHOWN



- NOTES:
- A. All linear dimensions are in inches (millimeters).
  - B. This drawing is subject to change without notice.
  - C Falls within JEDEC MS-001, except 18 and 20 pin minimum body length (Dim A).
  - D The 20 pin end lead shoulder width is a vendor option, either half or full width.

4040049/E 12/2002

# DW0020A



# PACKAGE OUTLINE

## SOIC - 2.65 mm max height

SOIC



**NOTES:**

1. All linear dimensions are in millimeters. Dimensions in parenthesis are for reference only. Dimensioning and tolerancing per ASME Y14.5M.
2. This drawing is subject to change without notice.
3. This dimension does not include mold flash, protrusions, or gate burrs. Mold flash, protrusions, or gate burrs shall not exceed 0.15 mm per side.
4. This dimension does not include interlead flash. Interlead flash shall not exceed 0.43 mm per side.
5. Reference JEDEC registration MS-013.

4220724/A 05/2016

# EXAMPLE BOARD LAYOUT

DW0020A

SOIC - 2.65 mm max height

SOIC



LAND PATTERN EXAMPLE  
SCALE:6X



SOLDER MASK DETAILS

4220724/A 05/2016

NOTES: (continued)

- 6. Publication IPC-7351 may have alternate designs.
- 7. Solder mask tolerances between and around signal pads can vary based on board fabrication site.

# EXAMPLE STENCIL DESIGN

DW0020A

SOIC - 2.65 mm max height

SOIC



SOLDER PASTE EXAMPLE  
BASED ON 0.125 mm THICK STENCIL  
SCALE:6X

4220724/A 05/2016

NOTES: (continued)

- 8. Laser cutting apertures with trapezoidal walls and rounded corners may offer better paste release. IPC-7525 may have alternate design recommendations.
- 9. Board assembly site may have different recommendations for stencil design.

## IMPORTANT NOTICE AND DISCLAIMER

TI PROVIDES TECHNICAL AND RELIABILITY DATA (INCLUDING DATA SHEETS), DESIGN RESOURCES (INCLUDING REFERENCE DESIGNS), APPLICATION OR OTHER DESIGN ADVICE, WEB TOOLS, SAFETY INFORMATION, AND OTHER RESOURCES "AS IS" AND WITH ALL FAULTS, AND DISCLAIMS ALL WARRANTIES, EXPRESS AND IMPLIED, INCLUDING WITHOUT LIMITATION ANY IMPLIED WARRANTIES OF MERCHANTABILITY, FITNESS FOR A PARTICULAR PURPOSE OR NON-INFRINGEMENT OF THIRD PARTY INTELLECTUAL PROPERTY RIGHTS.

These resources are intended for skilled developers designing with TI products. You are solely responsible for (1) selecting the appropriate TI products for your application, (2) designing, validating and testing your application, and (3) ensuring your application meets applicable standards, and any other safety, security, regulatory or other requirements.

These resources are subject to change without notice. TI grants you permission to use these resources only for development of an application that uses the TI products described in the resource. Other reproduction and display of these resources is prohibited. No license is granted to any other TI intellectual property right or to any third party intellectual property right. TI disclaims responsibility for, and you will fully indemnify TI and its representatives against, any claims, damages, costs, losses, and liabilities arising out of your use of these resources.

TI's products are provided subject to [TI's Terms of Sale](#) or other applicable terms available either on [ti.com](https://www.ti.com) or provided in conjunction with such TI products. TI's provision of these resources does not expand or otherwise alter TI's applicable warranties or warranty disclaimers for TI products.

TI objects to and rejects any additional or different terms you may have proposed.

Mailing Address: Texas Instruments, Post Office Box 655303, Dallas, Texas 75265  
Copyright © 2024, Texas Instruments Incorporated

## Looking for pricing, stock, or lifecycle information?

Click below to explore more details on WIN SOURCE:

 [View SN65LBC174A16DWR on WIN SOURCE](#)

 [Texas Instruments](#) Information

## Optimize Your Supply Chain with WIN SOURCE Solutions

-  Global Sourcing Solution
-  Obsolete Management
-  Cost Control Management
-  Shortage Management
-  Alternative Solution
-  Excess Inventory Management