



**THE DATASHEET OF
SN65HVD07DR**



SN65HVD0x, SN75HVD0x High Output RS-485 Transceivers

1 Features

- Minimum differential output voltage of 2.5 V Into a 54-Ω load
- Open-circuit, short-circuit, and idle-bus failsafe receiver
- 1/8th Unit-load option available (Up to 256 nodes on the bus)
- Bus-pin ESD protection exceeds 16 kV HBM
- Driver output slew rate control options
- Electrically compatible with ANSI TIA/EIA-485-A standard
- Low-current standby mode: 1 μA typical
- Glitch-free power-up and power-down protection for hot-plugging applications
- Pin compatible with industry standard SN75176

2 Applications

- Data transmission over long or lossy lines or electrically noisy environments
- Profibus line interface
- Industrial process control networks
- Point-of-sale (POS) networks
- Electric utility metering
- Building automation
- Digital motor control

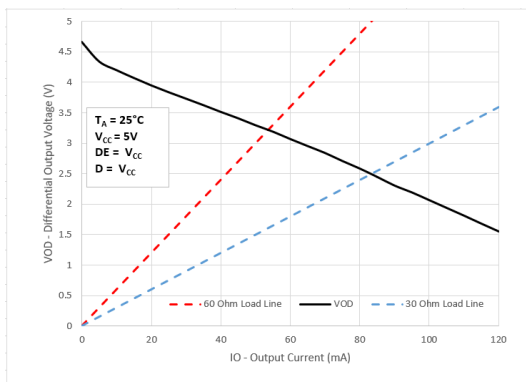

Figure 3-1. Differential Output Voltage vs Differential Output Current

3 Description

The SN65HVD05, SN75HVD05, SN65HVD06, SN75HVD06, SN65HVD07, and SN75HVD07 combine a 3-state differential line driver and differential line receiver. They are designed for balanced data transmission and interoperate with ANSI TIA/EIA-485-A and ISO 8482E standard-compliant devices. The driver is designed to provide a differential output voltage greater than that required by these standards for increased noise margin. The drivers and receivers have active-high and active-low enables respectively, which can be externally connected together to function as direction control.

The driver differential outputs and receiver differential inputs connect internally to form a differential input/output (I/O) bus port that is designed to offer minimum loading to the bus whenever the driver is disabled or not powered. These devices feature wide positive and negative common-mode voltage ranges, making them suitable for party-line applications.

D OR P PACKAGE (TOP VIEW)

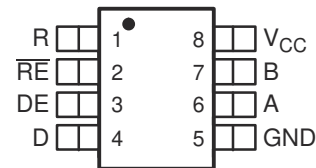

LOGIC DIAGRAM (POSITIVE LOGIC)

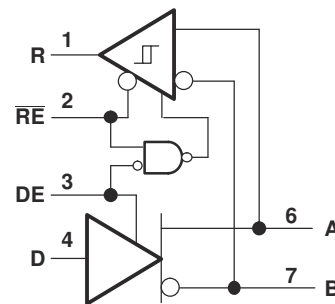

Table of Contents

1 Features	1	Parameter Measurement Information	12
2 Applications	1	6 Function Tables	16
3 Description	1	6.1 Receiver Failsafe.....	16
4 Revision History	2	7 Equivalent Input and Output Schematic Diagrams	17
5 Specifications	3	8 Application and Implementation	18
5.1 Absolute Maximum Ratings.....	3	Typical Application.....	18
5.2 Recommended Operating Conditions.....	3	9 Device and Documentation Support	19
5.3 Thermal Information.....	4	9.1 Receiving Notification of Documentation Updates....	19
5.4 Package Dissipation Ratings.....	4	9.2 Support Resources.....	19
5.5 Driver Electrical Characteristics.....	5	9.3 Trademarks.....	19
5.6 Driver Switching Characteristics.....	6	9.4 Electrostatic Discharge Caution.....	19
5.7 Receiver Electrical Characteristics.....	7	9.5 Glossary.....	19
5.8 Receiver Switching Characteristics.....	8	10 Mechanical, Packaging, and Orderable	
5.9 Typical Characteristics.....	9	Information	19

4 Revision History

NOTE: Page numbers for previous revisions may differ from page numbers in the current version.

Changes from Revision E (August 2009) to Revision F (March 2023)	Page
• Deleted the <i>Ordering Information</i> table.....	1
• Added the <i>Thermal Information</i> table.....	4
• Changed the <i>Typical Characteristics</i>	9

Changes from Revision D (July 2006) to Revision E (August 2009)	Page
• Added IDLE Bus to the Receivers Function Table.....	16
• Added the Receiver Failsafe paragraph.....	16

5 Specifications

5.1 Absolute Maximum Ratings

over operating free-air temperature range unless otherwise noted^{(1) (2)}

			SN65HVD05, SN65HVD06, SN65HVD07 SN75HVD05, SN75HVD06, SN75HVD07
Supply voltage range, V_{CC}			-0.3 V to 6 V
Voltage range at A or B			-9 V to 14 V
Input voltage range at D, DE, R or \overline{RE}			-0.5 V to $V_{CC} + 0.5$ V
Voltage input range, transient pulse, A and B, through 100 Ω (see Figure 6-11)			-50 V to 50 V
Receiver output current, I_O			-11 mA to 11mA
Electrostatic discharge	Human body model ⁽³⁾	A, B, and GND	16 kV
		All pins	4 kV
	Charged-device model ⁽⁴⁾	All pins	1 kV
Continuous total power dissipation			See Dissipation Rating Table

- (1) Stresses beyond those listed under "absolute maximum ratings" may cause permanent damage to the device. These are stress ratings only, and functional operation of the device at these or any other conditions beyond those indicated under "recommended operating conditions" is not implied. Exposure to absolute-maximum-rated conditions for extended periods may affect device reliability.
- (2) All voltage values, except differential I/O bus voltages, are with respect to network ground terminal.
- (3) Tested in accordance with JEDEC Standard 22, Test Method A114-A.
- (4) Tested in accordance with JEDEC Standard 22, Test Method C101.

5.2 Recommended Operating Conditions

		MIN	NOM	MAX	UNIT
Supply voltage, V_{CC}		4.5		5.5	V
Voltage at any bus terminal (separately or common mode) V_I or V_{IC}		-7 ⁽¹⁾		12	V
High-level input voltage, V_{IH}	D, DE, \overline{RE}	2			V
Low-level input voltage, V_{IL}	D, DE, \overline{RE}			0.8	V
Differential input voltage, V_{ID} (see Figure 6-7)		-12		12	V
High-level output current, I_{OH}	Driver	-100			mA
	Receiver	-8			
Low-level output current, I_{OL}	Driver			100	mA
	Receiver			8	
Operating free-air temperature, T_A	SN65HVD05	-40		85	$^{\circ}\text{C}$
	SN65HVD06				
	SN65HVD07				
	SN75HVD05	0		70	$^{\circ}\text{C}$
	SN75HVD06				
	SN75HVD07				

- (1) The algebraic convention, in which the least positive (most negative) limit is designated as minimum is used in this data sheet.

5.3 Thermal Information

THERMAL METRIC ⁽¹⁾		D (SOIC) SN65 Variation	D (SOIC) SN75 Variation	P (PDIP)	UNIT
		8 PINS	8 PINS	8 PINS	
R _{θJA}	Junction-to-ambient thermal resistance	116.7	175.4	125	°C/W
R _{θJC(top)}	Junction-to-case (top) thermal resistance	56.3	53.6	34.9	°C/W
R _{θJB}	Junction-to-board thermal resistance	63.4	45.1	23.7	°C/W
ψ _{JT}	Junction-to-top characterization parameter	8.8	10.1	12.1	°C/W
ψ _{JB}	Junction-to-board characterization parameter	62.6	44.4	23.6	°C/W

(1) For more information about traditional and new thermal metrics, see the *Semiconductor and IC Package Thermal Metrics* application report, [SPRA953](#).

5.4 Package Dissipation Ratings

(See [Figure 5-1](#) and [Figure 5-2](#))

PACKAGE	T _A ≤ 25°C POWER RATING	DERATING FACTOR ⁽¹⁾ ABOVE T _A = 25°C	T _A = 70°C POWER RATING	T _A = 85°C POWER RATING
D ⁽²⁾	710 mW	5.7 mW/°C	455 mW	369 mW
D ⁽³⁾	1282 mW	10.3 mW/°C	821 mW	667 mW
P	1000 mW	8.0 m W/°C	640 mW	520 mW

(1) This is the inverse of the junction-to-ambient thermal resistance when board-mounted and with no air flow.

(2) Tested in accordance with the Low-K thermal metric definitions of EIA/JESD51-3

(3) Tested in accordance with the High-K thermal metric definitions of EIA/JESD51-7

5.5 Driver Electrical Characteristics

over operating free-air temperature range unless otherwise noted

PARAMETER		TEST CONDITIONS		MIN	TYP ⁽¹⁾	MAX	UNIT
V _{IK}	Input clamp voltage	I _I = -18 mA		-1.5			V
V _{OD}	Differential output voltage	No Load				V _{CC}	V
		R _L = 54 Ω, See Figure 6-4		2.5			
		V _{test} = -7 V to 12 V, See Figure 6-2		2.2			
Δ V _{OD}	Change in magnitude of differential output voltage	See Figure 6-4 and Figure 6-2		-0.2		0.2	V
V _{OC(SS)}	Steady-state common-mode output voltage	See Figure 6-3		2.2		3.3	V
ΔV _{OC(SS)}	Change in steady-state common-mode output voltage	See Figure 6-3		-0.1		0.1	V
V _{OC(PP)}	Peak-to-peak common-mode output voltage	HVD05	See Figure 6-3		600		mV
		HVD06		500			
		HVD07		900			
I _{OZ}	High-impedance output current	See receiver input currents					
I _I	Input current	D		-100		0	μA
		DE		0		100	
I _{OS}	Short-circuit output current	-7 V ≤ V _O ≤ 12 V		-250		250	mA
C _(diff)	Differential output capacitance	V _{ID} = 0.4 sin(4E6πt) + 0.5 V, DE at 0 V			16		pF
I _{CC}	Supply current	RE at V _{CC} , D and DE at V _{CC} , No load	Receiver disabled and driver enabled		9	15	mA
		RE at V _{CC} , D at V _{CC} DE at 0 V, No load	Receiver disabled and driver disabled (standby)		1	5	μA
		RE at 0 V, D and DE at V _{CC} , No load	Receiver enabled and driver enabled		9	15	mA

(1) All typical values are at 25°C and with a 5-V supply.

5.6 Driver Switching Characteristics

over operating free-air temperature range unless otherwise noted

PARAMETER		TEST CONDITIONS	MIN	TYP ⁽¹⁾	MAX	UNIT		
t _{PLH}	Propagation delay time, low-to-high-level output	R _L = 54 Ω, C _L = 50 pF, See Figure 6-4	HVD05	6.5	11	ns		
				HVD06	27		40	
				HVD07	250		400	
t _{PHL}	Propagation delay time, high-to-low-level output		HVD05	6.5	11	ns		
				HVD06	27		40	
				HVD07	250		400	
t _r	Differential output signal rise time		HVD05	2.7	3.6	6	ns	
				HVD06	18	28		55
				HVD07	150	300		450
t _f	Differential output signal fall time	HVD05	2.7	3.6	6	ns		
			HVD06	18	28		55	
			HVD07	150	300		450	
t _{sk(p)}	Pulse skew ((t _{PHL} - t _{PLH}))	HVD05			2	ns		
			HVD06				2.5	
			HVD07				10	
t _{sk(pp)} ⁽²⁾	Part-to-part skew	HVD05			3.5	ns		
			HVD06				14	
			HVD07				100	
t _{PZH1}	Propagation delay time, high-impedance-to-high-level output	HVD05			25	ns		
			HVD06				45	
			HVD07				250	
t _{PHZ}	Propagation delay time, high-level-to-high-impedance output	HVD05			25	ns		
			HVD06				60	
			HVD07				250	
t _{PZL1}	Propagation delay time, high-impedance-to-low-level output	HVD05			15	ns		
			HVD06				45	
			HVD07				200	
t _{PLZ}	Propagation delay time, low-level-to-high-impedance output	HVD05			14	ns		
			HVD06				90	
			HVD07				550	
t _{PZH2}	Propagation delay time, standby-to-high-level output	R _L = 110 Ω, \overline{RE} at 3 V, See Figure 6-5			6	μs		
t _{PZL2}	Propagation delay time, standby-to-low-level output	R _L = 110 Ω, \overline{RE} at 3 V, See Figure 6-6			6	μs		

(1) All typical values are at 25°C and with a 5-V supply.

(2) t_{sk(pp)} is the magnitude of the difference in propagation delay times between any specified terminals of two devices when both devices operate with the same supply voltages, at the same temperature, and have identical packages and test circuits.

5.7 Receiver Electrical Characteristics

over operating free-air temperature range unless otherwise noted

PARAMETER		TEST CONDITIONS		MIN	TYP ⁽¹⁾	MAX	UNIT	
V_{IT+}	Positive-going input threshold voltage	$I_O = -8 \text{ mA}$				-0.01	V	
V_{IT-}	Negative-going input threshold voltage	$I_O = 8 \text{ mA}$		-0.2				
V_{hys}	Hysteresis voltage ($V_{IT+} - V_{IT-}$)				35		mV	
V_{IK}	Enable-input clamp voltage	$I_I = -18 \text{ mA}$		-1.5			V	
V_{OH}	High-level output voltage	$V_{ID} = 200 \text{ mV}$,	$I_{OH} = -8 \text{ mA}$,	See Figure 6-7		4	V	
V_{OL}	Low-level output voltage	$V_{ID} = -200 \text{ mV}$,	$I_{OL} = 8 \text{ mA}$,	See Figure 6-7		0.4	V	
I_{OZ}	High-impedance-state output current	$V_O = 0 \text{ or } V_{CC}$	\overline{RE} at V_{CC}	-1		1	μA	
I_I	Bus input current	HVD05	Other input at 0 V	$V_A \text{ or } V_B = 12 \text{ V}$		0.23	0.5	mA
				$V_A \text{ or } V_B = 12 \text{ V}, V_{CC} = 0 \text{ V}$		0.3	0.5	
				$V_A \text{ or } V_B = -7 \text{ V}$		-0.4	0.13	
				$V_A \text{ or } V_B = -7 \text{ V}, V_{CC} = 0 \text{ V}$		-0.4	0.15	
		HVD06 HVD07	Other input at 0 V	$V_A \text{ or } V_B = 12 \text{ V}$		0.06	0.1	mA
				$V_A \text{ or } V_B = 12 \text{ V}, V_{CC} = 0 \text{ V}$		0.08	0.13	
				$V_A \text{ or } V_B = -7 \text{ V}$		-0.1	0.05	
				$V_A \text{ or } V_B = -7 \text{ V}, V_{CC} = 0 \text{ V}$		-0.05	0.03	
I_{IH}	High-level input current, \overline{RE}	$V_{IH} = 2 \text{ V}$		-60	26.4		μA	
I_{IL}	Low-level input current, \overline{RE}	$V_{IL} = 0.8 \text{ V}$		-60	27.4		μA	
$C_{(diff)}$	Differential input capacitance	$V_I = 0.4 \sin(4E6\pi t) + 0.5 \text{ V}$, DE at 0 V			16		pF	
I_{CC}	Supply current	\overline{RE} at 0 V, D and DE at 0 V, No load	Receiver enabled and driver disabled	5	10		mA	
		\overline{RE} at V_{CC} , DE at 0 V, D at V_{CC} , No load	Receiver disabled and driver disabled (standby)	1	5		μA	
		\overline{RE} at 0 V, D and DE at V_{CC} , No load	Receiver enabled and driver enabled	9	15		mA	

(1) All typical values are at 25°C and with a 5-V supply.

5.8 Receiver Switching Characteristics

over operating free-air temperature range unless otherwise noted

PARAMETER			TEST CONDITIONS	MIN	TYP ⁽¹⁾	MAX	UNIT	
t_{PLH}	Propagation delay time, low-to-high-level output 1/2 UL	HVD05	$V_{ID} = -1.5\text{ V to }1.5\text{ V},$ $C_L = 15\text{ pF},$ See Figure 6-8		14.6	25	ns	
t_{PHL}	Propagation delay time, high-to-low-level output 1/2 UL	HVD05			14.6	25	ns	
t_{PLH}	Propagation delay time, low-to-high-level output 1/8 UL	HVD06			55	70	ns	
		HVD07			55	70		
t_{PHL}	Propagation delay time, high-to-low-level output 1/8 UL	HVD06			55	70	ns	
		HVD07			55	70		
$t_{sk(p)}$	Pulse skew ($ t_{PHL} - t_{PLH} $)	HVD05					2	ns
		HVD06					4.5	
		HVD07					4.5	
$t_{sk(pp)}$ ⁽²⁾	Part-to-part skew	HVD05					6.5	ns
		HVD06				14		
		HVD07				14		
t_r	Output signal rise time		$C_L = 15\text{ pF},$ See Figure 6-8		2	3	ns	
t_f	Output signal fall time				2	3		
t_{PZH1}	Output enable time to high level		$C_L = 15\text{ pF},$ DE at 3 V, See Figure 6-9			10	ns	
t_{PZL1}	Output enable time to low level					10		
t_{PHZ}	Output disable time from high level					15		
t_{PLZ}	Output disable time from low level					15		
t_{PZH2}	Propagation delay time, standby-to-high-level output		$C_L = 15\text{ pF},$ DE at 0, See Figure 6-10			6	μs	
t_{PZL2}	Propagation delay time, standby-to-low-level output					6		

(1) All typical values are at 25°C and with a 5-V supply.

(2) $t_{sk(pp)}$ is the magnitude of the difference in propagation delay times between any specified terminals of two devices when both devices operate with the same supply voltages, at the same temperature, and have identical packages and test circuits.

5.9 Typical Characteristics

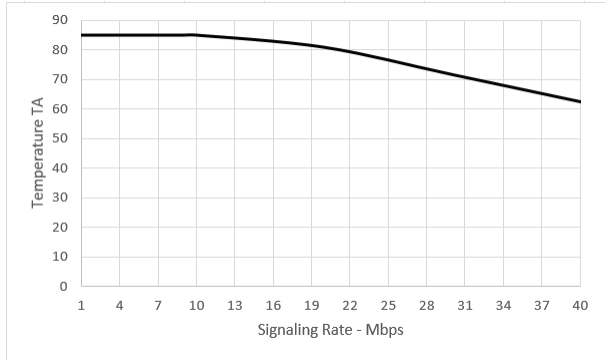

Figure 5-1. HVD05 Maximum Recommended Still-Air Operating Temperature vs Signaling Rate (D-Package)

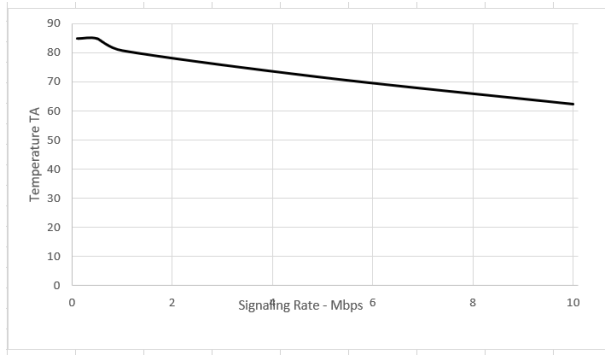

Figure 5-2. HVD06 Maximum Recommended Still-Air Operating Temperature vs Signaling Rate (D-Package)

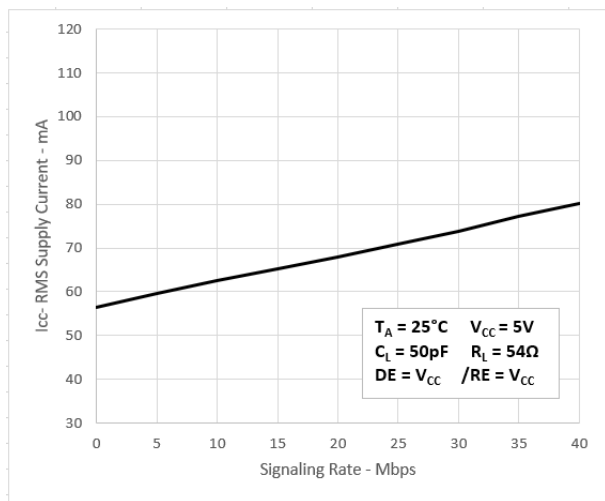

Figure 5-3. HVD05 RMS Supply Current vs Signaling Rate

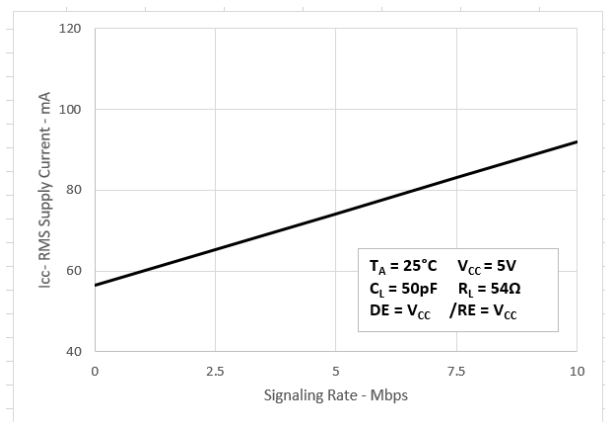

Figure 5-4. HVD06 RMS Supply Current vs Signaling Rate

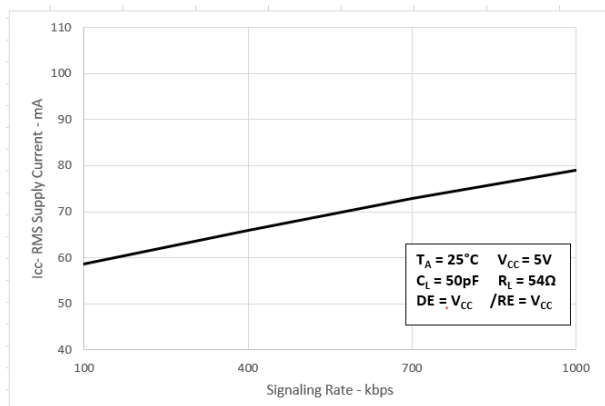

Figure 5-5. HVD07 RMS Supply Current vs Signaling Rate

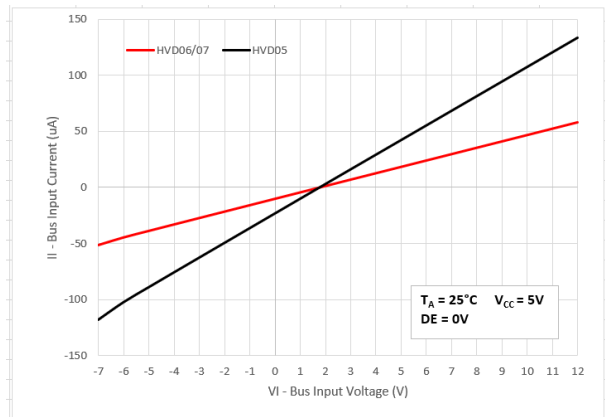

Figure 5-6. BUS Input Current vs BUS Input Voltage

5.9 Typical Characteristics (continued)

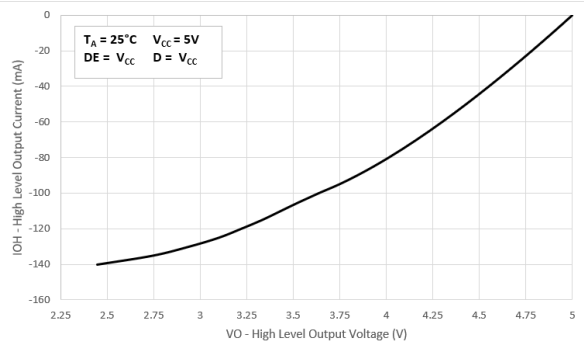

Figure 5-7. Driver High-Level Output Current vs High-Level Output Voltage

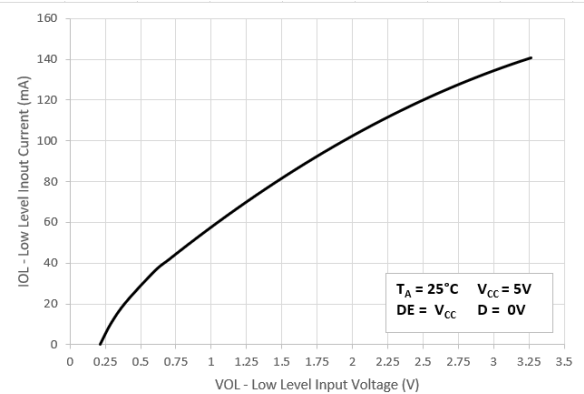

Figure 5-8. Driver Low-Level Output Current vs Low-Level Output Voltage

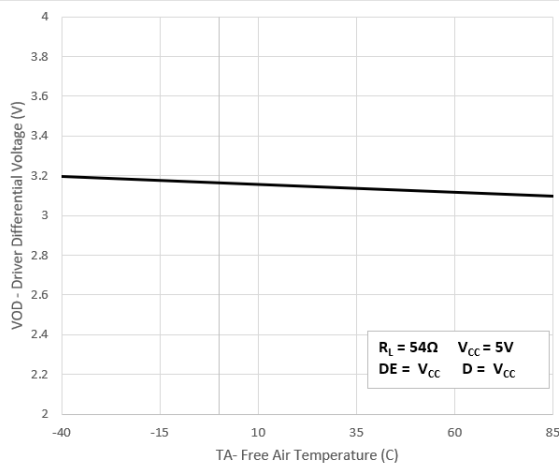

Figure 5-9. Differential Output Voltage vs Free-Air Temperature

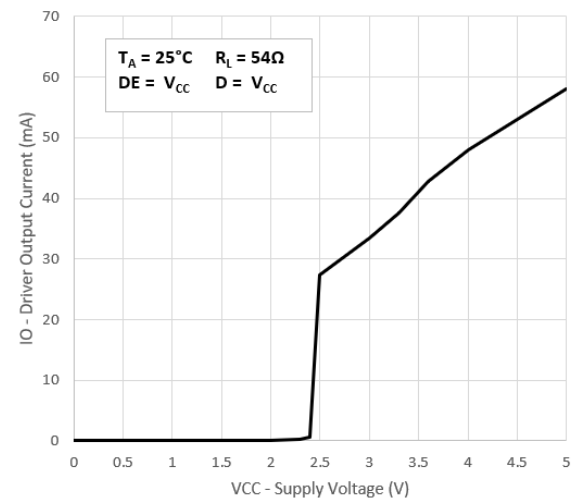

Figure 5-10. Driver Output Current vs Supply Voltage

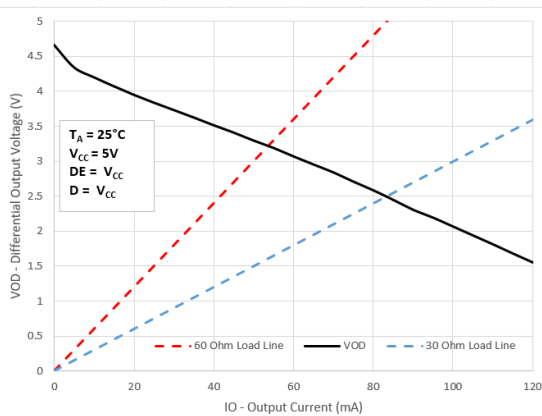
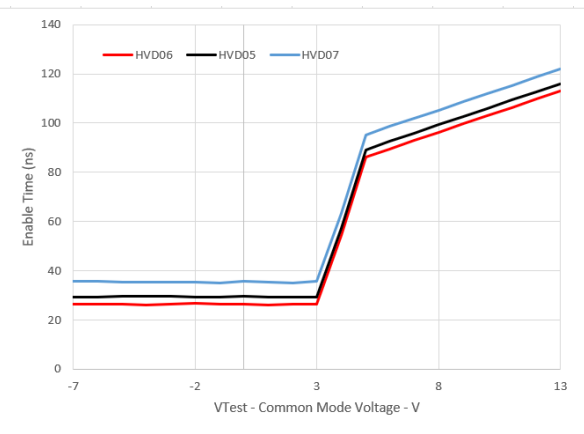

Figure 5-11. Differential Output Voltage vs Differential Output Current



**Figure 5-12. Enable Time vs Common-Mode Voltage
(See Figure 5-13)**

5.9 Typical Characteristics (continued)

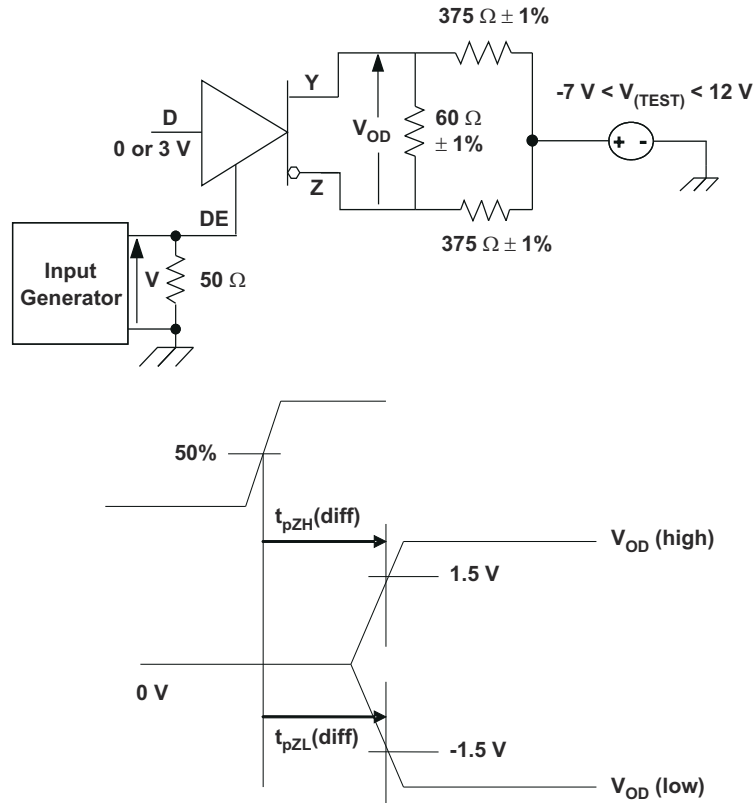

Figure 5-13. Driver Enable Time From DE to V_{OD}

Parameter Measurement Information

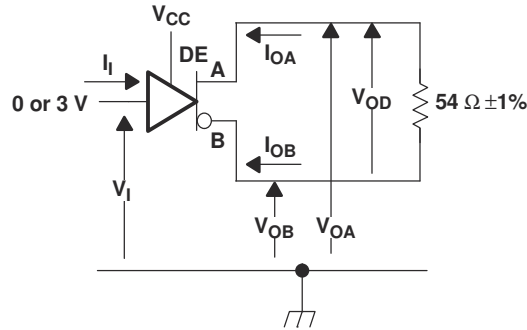

Figure 6-1. Driver V_{OD} Test Circuit and Voltage and Current Definitions

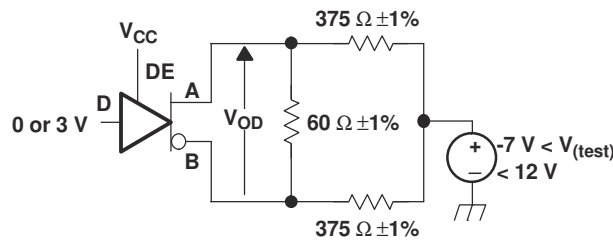

Figure 6-2. Driver V_{OD} With Common-Mode Loading Test Circuit

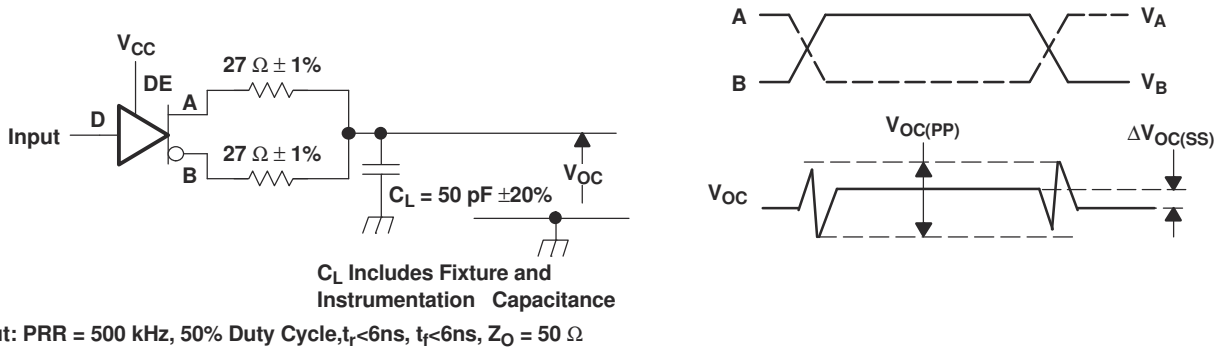

Figure 6-3. Test Circuit and Definitions for the Driver Common-Mode Output Voltage

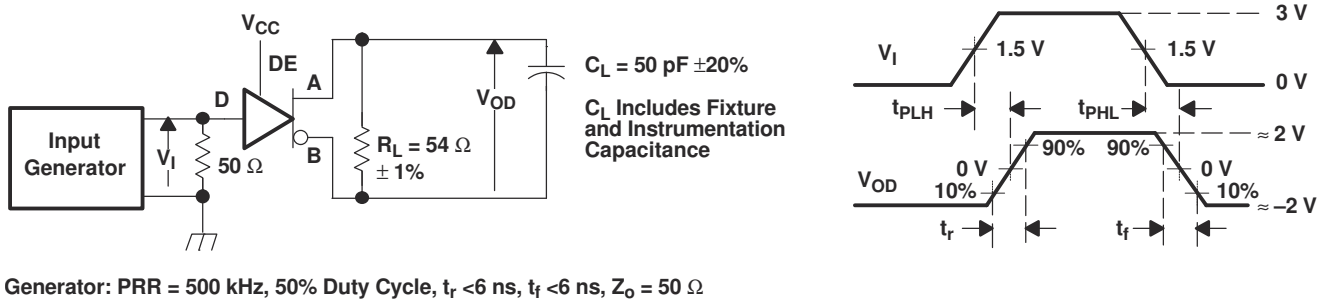
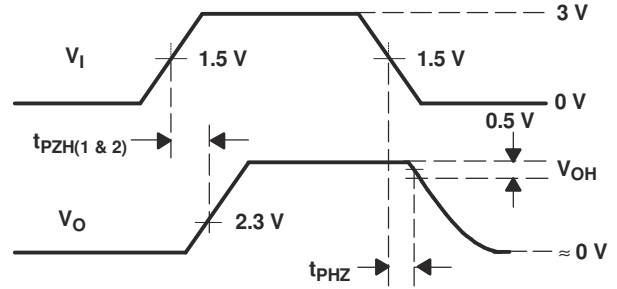
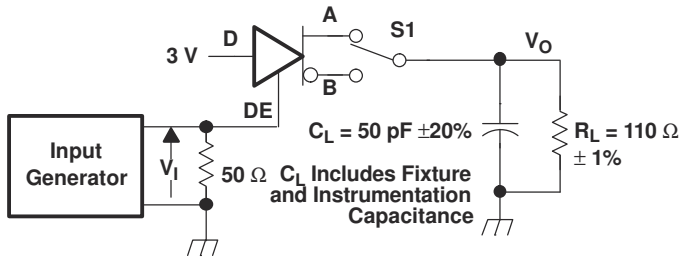
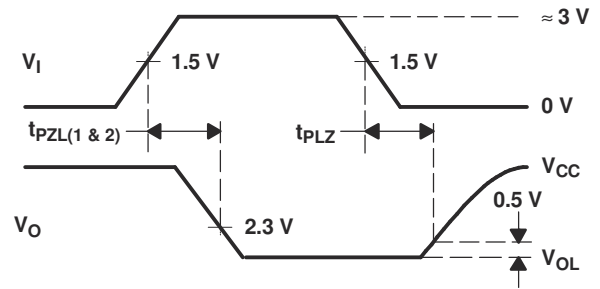
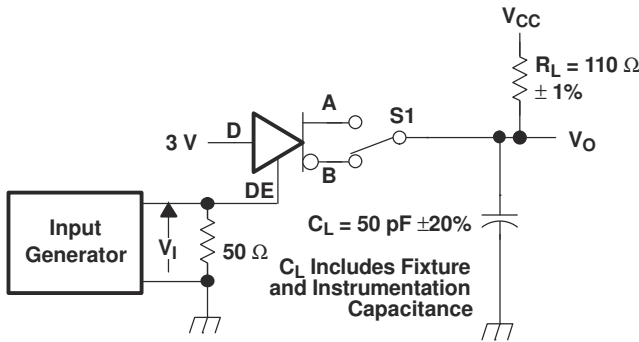

Figure 6-4. Driver Switching Test Circuit and Voltage Waveforms



Generator: PRR = 100 kHz, 50% Duty Cycle, $t_r < 6$ ns, $t_f < 6$ ns, $Z_o = 50 \Omega$

Figure 6-5. Driver High-Level Enable and Disable Time Test Circuit and Voltage Waveforms



Generator: PRR = 100 kHz, 50% Duty Cycle, $t_r < 6$ ns, $t_f < 6$ ns, $Z_o = 50 \Omega$

Figure 6-6. Driver Low-Level Output Enable and Disable Time Test Circuit and Voltage Waveforms

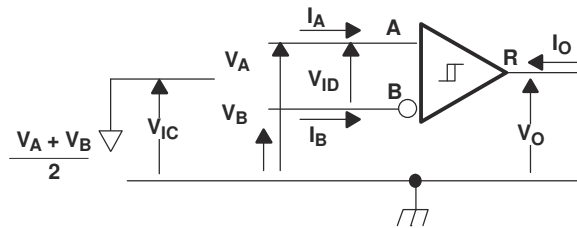
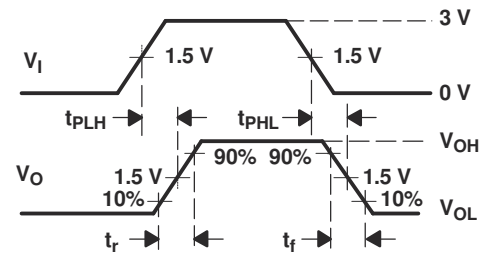
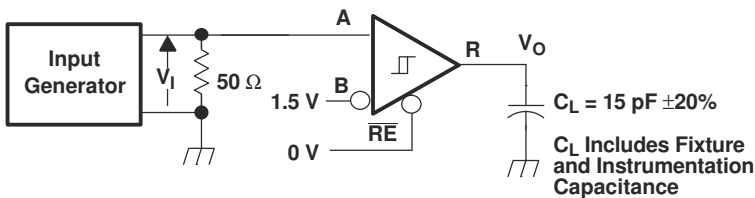

Figure 6-7. Receiver Voltage and Current Definitions



Generator: PRR = 100 kHz, 50% Duty Cycle, $t_r < 6$ ns, $t_f < 6$ ns, $Z_o = 50 \Omega$

Figure 6-8. Receiver Switching Test Circuit and Voltage Waveforms

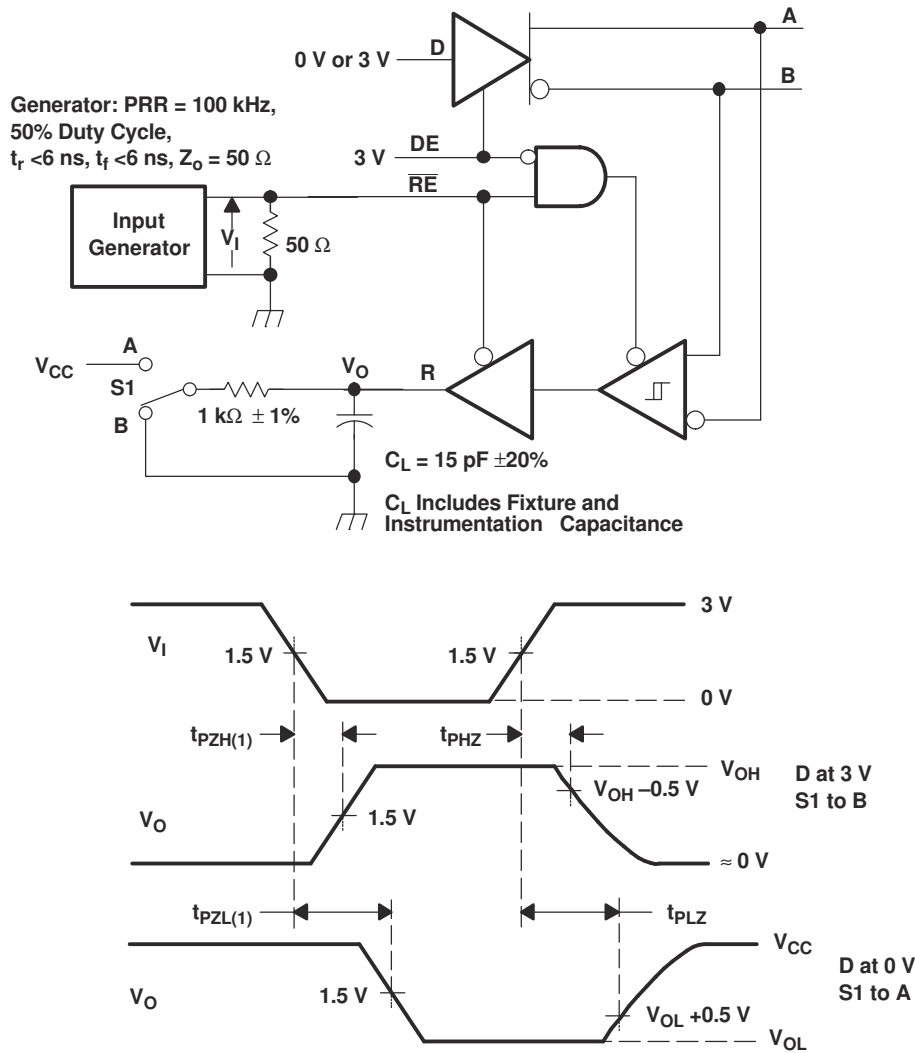

Figure 6-9. Receiver Enable and Disable Time Test Circuit and Voltage Waveforms With Drivers Enabled

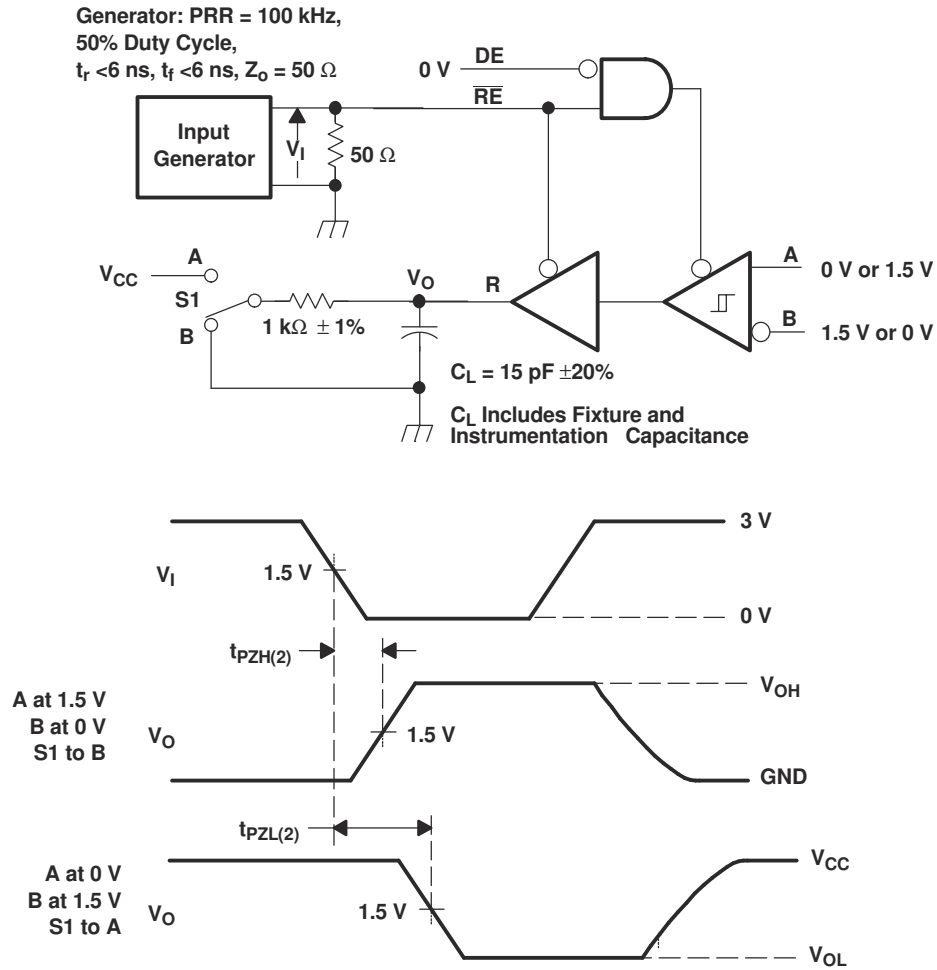
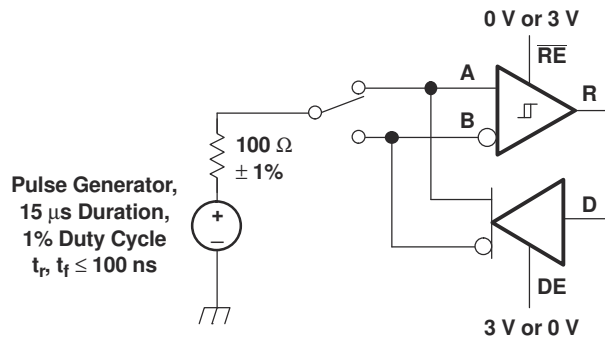

Figure 6-10. Receiver Enable Time From Standby (Driver Disabled)



NOTE: This test is conducted to test survivability only. Data stability at the R output is not specified.

Figure 6-11. Test Circuit, Transient Over Voltage Test

6 Function Tables

Table 6-1. DRIVER

INPUT	ENABLE	OUTPUTS	
	DE	A	B
H	H	H	L
L	H	L	H
X	L	Z	Z
Open	H	H	L
X	Open	Z	Z

Table 6-2. RECEIVER

DIFFERENTIAL INPUTS ⁽¹⁾	ENABLE	OUTPUT
$V_{ID} = V_A - V_B$	\overline{RE}	R
$V_{ID} \leq -0.2\text{ V}$	L	L
$-0.2\text{ V} < V_{ID} < -0.01\text{ V}$	L	?
$-0.01\text{ V} \leq V_{ID}$	L	H
X	H	Z
Open Circuit	L	H
Short Circuit	L	H
IDLE Bus	L	H
X	Open	Z

(1) H = high level; L = low level; Z = high impedance; X = irrelevant;
 ? = indeterminate

6.1 Receiver Failsafe

The differential receiver is “failsafe” to invalid bus states caused by:

- open bus conditions such as a disconnected connector,
- shorted bus conditions such as cable damage shorting the twisted-pair together, or
- idle bus conditions that occur when no driver on the bus is actively driving

In any of these cases, the differential receiver outputs a failsafe logic High state, so that the output of the receiver is not indeterminate.

Receiver failsafe is accomplished by offsetting the receiver thresholds so that the “input indeterminate” range does not include zero volts differential. To comply with the RS-422 and RS-485 standards, the receiver output *must* output a High when the differential input V_{ID} is more positive than +200 mV, and *must* output a Low when the V_{ID} is more negative than -200 mV. The receiver parameters which determine the failsafe performance are V_{IT+} and V_{IT-} and V_{HYS} . As seen in the [Receiver Electrical Characteristics](#) table, differential signals more negative than -200 mV will always cause a Low receiver output. Similarly, differential signals more positive than +200 mV will *always* cause a High receiver output.

When the differential input signal is close to zero, it will still be above the V_{IT+} threshold, and the receiver output is High. Only when the differential input is more negative than V_{IT-} will the receiver output transition to a Low state. So, the noise immunity of the receiver inputs during a bus fault condition includes the receiver hysteresis value V_{HYS} (the separation between V_{IT+} and V_{IT-}) as well as the value of V_{IT+} .

7 Equivalent Input and Output Schematic Diagrams

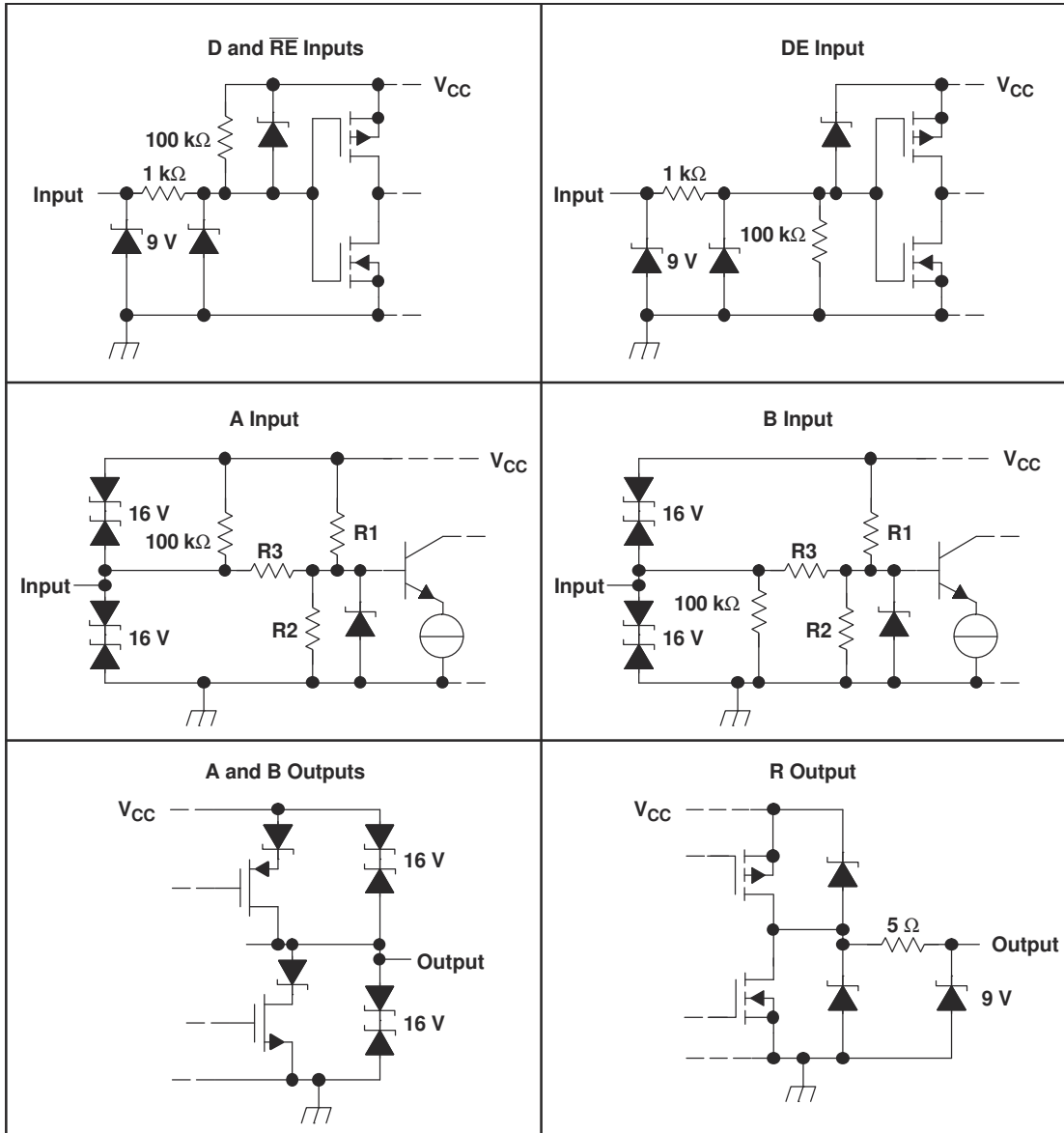

	R1/R2	R3
SN65HVD05	9 kΩ	45 kΩ
SN65HVD06	36 kΩ	180 kΩ
SN65HVD07	36 kΩ	180 kΩ

8 Application and Implementation

Note

Information in the following applications sections is not part of the TI component specification, and TI does not warrant its accuracy or completeness. TI's customers are responsible for determining suitability of components for their purposes, as well as validating and testing their design implementation to confirm system functionality.

Typical Application

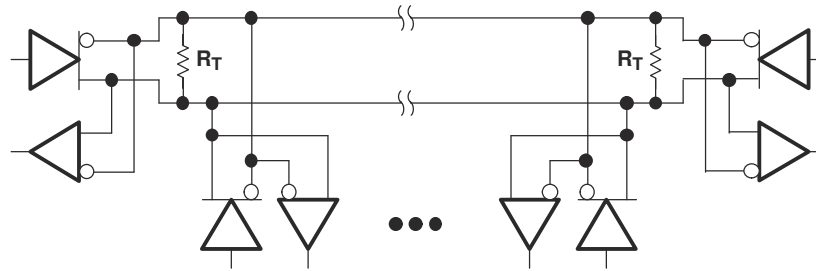

Device	Number of Devices on Bus
HVD05	64
HVD06	256
HVD07	256

NOTE: The line should be terminated at both ends with its characteristic impedance ($R_T = Z_0$).
 Stub lengths off the main line should be kept as short as possible.

Figure 8-1. Typical Application Circuit

9 Device and Documentation Support

9.1 Receiving Notification of Documentation Updates

To receive notification of documentation updates, navigate to the device product folder on ti.com. Click on *Subscribe to updates* to register and receive a weekly digest of any product information that has changed. For change details, review the revision history included in any revised document.

9.2 Support Resources

[TI E2E™ support forums](#) are an engineer's go-to source for fast, verified answers and design help — straight from the experts. Search existing answers or ask your own question to get the quick design help you need.

Linked content is provided "AS IS" by the respective contributors. They do not constitute TI specifications and do not necessarily reflect TI's views; see TI's [Terms of Use](#).

9.3 Trademarks

TI E2E™ is a trademark of Texas Instruments.
All trademarks are the property of their respective owners.

9.4 Electrostatic Discharge Caution



This integrated circuit can be damaged by ESD. Texas Instruments recommends that all integrated circuits be handled with appropriate precautions. Failure to observe proper handling and installation procedures can cause damage.

ESD damage can range from subtle performance degradation to complete device failure. Precision integrated circuits may be more susceptible to damage because very small parametric changes could cause the device not to meet its published specifications.

9.5 Glossary

[TI Glossary](#) This glossary lists and explains terms, acronyms, and definitions.

10 Mechanical, Packaging, and Orderable Information

The following pages include mechanical, packaging, and orderable information. This information is the most current data available for the designated devices. This data is subject to change without notice and revision of this document. For browser-based versions of this data sheet, refer to the left-hand navigation.

PACKAGING INFORMATION

Orderable Device	Status (1)	Package Type	Package Drawing	Pins	Package Qty	Eco Plan (2)	Lead finish/ Ball material (6)	MSL Peak Temp (3)	Op Temp (°C)	Device Marking (4/5)	Samples
SN65HVD05DR	ACTIVE	SOIC	D	8	2500	RoHS & Green	NIPDAU	Level-1-260C-UNLIM	-40 to 85	VP05	Samples
SN65HVD05P	ACTIVE	PDIP	P	8	50	RoHS & Green	NIPDAU	N / A for Pkg Type	-40 to 85	65HVD05	Samples
SN65HVD06DR	ACTIVE	SOIC	D	8	2500	RoHS & Green	NIPDAU	Level-1-260C-UNLIM	-40 to 85	VP06	Samples
SN65HVD06P	ACTIVE	PDIP	P	8	50	RoHS & Green	NIPDAU	N / A for Pkg Type	-40 to 85	65HVD06	Samples
SN65HVD07DR	ACTIVE	SOIC	D	8	2500	RoHS & Green	NIPDAU	Level-1-260C-UNLIM	-40 to 85	VP07	Samples
SN65HVD07P	ACTIVE	PDIP	P	8	50	RoHS & Green	NIPDAU	N / A for Pkg Type	-40 to 85	65HVD07	Samples
SN75HVD06D	ACTIVE	SOIC	D	8	75	RoHS & Green	NIPDAU	Level-1-260C-UNLIM	0 to 70	VN06	Samples
SN75HVD06DR	ACTIVE	SOIC	D	8	2500	RoHS & Green	NIPDAU	Level-1-260C-UNLIM	0 to 70	VN06	Samples
SN75HVD07D	ACTIVE	SOIC	D	8	75	RoHS & Green	NIPDAU	Level-1-260C-UNLIM	0 to 70	VN07	Samples
SN75HVD07DR	ACTIVE	SOIC	D	8	2500	RoHS & Green	NIPDAU	Level-1-260C-UNLIM	0 to 70	VN07	Samples
SN75HVD07P	ACTIVE	PDIP	P	8	50	RoHS & Green	NIPDAU	N / A for Pkg Type	0 to 70	75HVD07	Samples

(1) The marketing status values are defined as follows:

ACTIVE: Product device recommended for new designs.

LIFEBUY: TI has announced that the device will be discontinued, and a lifetime-buy period is in effect.

NRND: Not recommended for new designs. Device is in production to support existing customers, but TI does not recommend using this part in a new design.

PREVIEW: Device has been announced but is not in production. Samples may or may not be available.

OBSOLETE: TI has discontinued the production of the device.

(2) **RoHS:** TI defines "RoHS" to mean semiconductor products that are compliant with the current EU RoHS requirements for all 10 RoHS substances, including the requirement that RoHS substance do not exceed 0.1% by weight in homogeneous materials. Where designed to be soldered at high temperatures, "RoHS" products are suitable for use in specified lead-free processes. TI may reference these types of products as "Pb-Free".

RoHS Exempt: TI defines "RoHS Exempt" to mean products that contain lead but are compliant with EU RoHS pursuant to a specific EU RoHS exemption.

Green: TI defines "Green" to mean the content of Chlorine (Cl) and Bromine (Br) based flame retardants meet JS709B low halogen requirements of <=1000ppm threshold. Antimony trioxide based flame retardants must also meet the <=1000ppm threshold requirement.

(3) MSL, Peak Temp. - The Moisture Sensitivity Level rating according to the JEDEC industry standard classifications, and peak solder temperature.

(4) There may be additional marking, which relates to the logo, the lot trace code information, or the environmental category on the device.

(5) Multiple Device Markings will be inside parentheses. Only one Device Marking contained in parentheses and separated by a "~" will appear on a device. If a line is indented then it is a continuation of the previous line and the two combined represent the entire Device Marking for that device.

(6) Lead finish/Ball material - Orderable Devices may have multiple material finish options. Finish options are separated by a vertical ruled line. Lead finish/Ball material values may wrap to two lines if the finish value exceeds the maximum column width.

Important Information and Disclaimer:The information provided on this page represents TI's knowledge and belief as of the date that it is provided. TI bases its knowledge and belief on information provided by third parties, and makes no representation or warranty as to the accuracy of such information. Efforts are underway to better integrate information from third parties. TI has taken and continues to take reasonable steps to provide representative and accurate information but may not have conducted destructive testing or chemical analysis on incoming materials and chemicals. TI and TI suppliers consider certain information to be proprietary, and thus CAS numbers and other limited information may not be available for release.

In no event shall TI's liability arising out of such information exceed the total purchase price of the TI part(s) at issue in this document sold by TI to Customer on an annual basis.

TAPE AND REEL INFORMATION

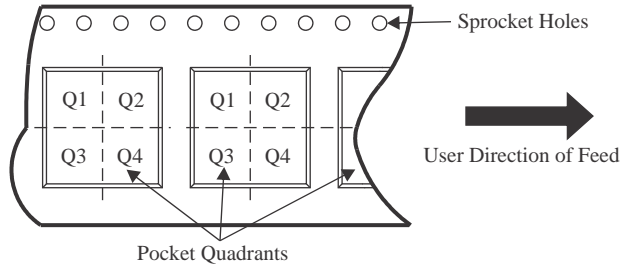
QUADRANT ASSIGNMENTS FOR PIN 1 ORIENTATION IN TAPE

*All dimensions are nominal

Device	Package Type	Package Drawing	Pins	SPQ	Reel Diameter (mm)	Reel Width W1 (mm)	A0 (mm)	B0 (mm)	K0 (mm)	P1 (mm)	W (mm)	Pin1 Quadrant
SN65HVD05DR	SOIC	D	8	2500	330.0	12.4	6.4	5.2	2.1	8.0	12.0	Q1
SN65HVD06DR	SOIC	D	8	2500	330.0	12.4	6.4	5.2	2.1	8.0	12.0	Q1
SN65HVD07DR	SOIC	D	8	2500	330.0	12.4	6.4	5.2	2.1	8.0	12.0	Q1
SN75HVD06DR	SOIC	D	8	2500	330.0	12.4	6.4	5.2	2.1	8.0	12.0	Q1
SN75HVD07DR	SOIC	D	8	2500	330.0	12.4	6.4	5.2	2.1	8.0	12.0	Q1

TAPE AND REEL BOX DIMENSIONS



*All dimensions are nominal

Device	Package Type	Package Drawing	Pins	SPQ	Length (mm)	Width (mm)	Height (mm)
SN65HVD05DR	SOIC	D	8	2500	356.0	356.0	35.0
SN65HVD06DR	SOIC	D	8	2500	356.0	356.0	35.0
SN65HVD07DR	SOIC	D	8	2500	356.0	356.0	35.0
SN75HVD06DR	SOIC	D	8	2500	340.5	336.1	25.0
SN75HVD07DR	SOIC	D	8	2500	340.5	338.1	20.6

TUBE

*All dimensions are nominal

Device	Package Name	Package Type	Pins	SPQ	L (mm)	W (mm)	T (μm)	B (mm)
SN65HVD05P	P	PDIP	8	50	506	13.97	11230	4.32
SN65HVD06P	P	PDIP	8	50	506	13.97	11230	4.32
SN65HVD07P	P	PDIP	8	50	506	13.97	11230	4.32
SN75HVD06D	D	SOIC	8	75	507	8	3940	4.32
SN75HVD07D	D	SOIC	8	75	507	8	3940	4.32
SN75HVD07P	P	PDIP	8	50	506	13.97	11230	4.32



D0008A

PACKAGE OUTLINE

SOIC - 1.75 mm max height

SMALL OUTLINE INTEGRATED CIRCUIT



4214825/C 02/2019

NOTES:

- Linear dimensions are in inches [millimeters]. Dimensions in parenthesis are for reference only. Controlling dimensions are in inches. Dimensioning and tolerancing per ASME Y14.5M.
- This drawing is subject to change without notice.
- This dimension does not include mold flash, protrusions, or gate burrs. Mold flash, protrusions, or gate burrs shall not exceed $.006$ [0.15] per side.
- This dimension does not include interlead flash.
- Reference JEDEC registration MS-012, variation AA.

EXAMPLE BOARD LAYOUT

D0008A

SOIC - 1.75 mm max height

SMALL OUTLINE INTEGRATED CIRCUIT



LAND PATTERN EXAMPLE
 EXPOSED METAL SHOWN
 SCALE:8X



SOLDER MASK DETAILS

4214825/C 02/2019

NOTES: (continued)

- 6. Publication IPC-7351 may have alternate designs.
- 7. Solder mask tolerances between and around signal pads can vary based on board fabrication site.

EXAMPLE STENCIL DESIGN

D0008A

SOIC - 1.75 mm max height

SMALL OUTLINE INTEGRATED CIRCUIT



SOLDER PASTE EXAMPLE
BASED ON .005 INCH [0.125 MM] THICK STENCIL
SCALE:8X

4214825/C 02/2019

NOTES: (continued)

8. Laser cutting apertures with trapezoidal walls and rounded corners may offer better paste release. IPC-7525 may have alternate design recommendations.
9. Board assembly site may have different recommendations for stencil design.

P (R-PDIP-T8)

PLASTIC DUAL-IN-LINE PACKAGE

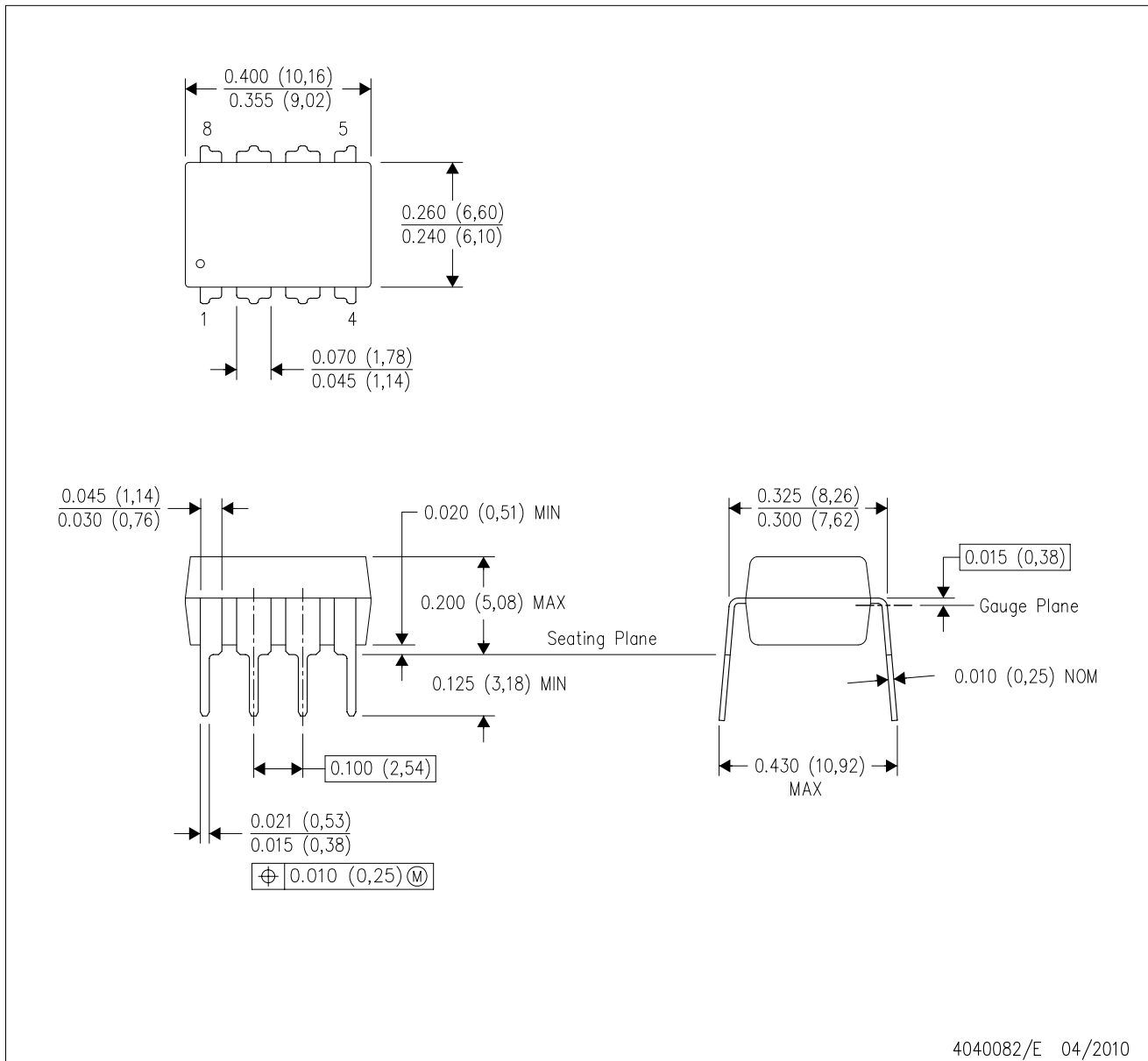

4040082/E 04/2010

- NOTES:
- A. All linear dimensions are in inches (millimeters).
 - B. This drawing is subject to change without notice.
 - C. Falls within JEDEC MS-001 variation BA.

IMPORTANT NOTICE AND DISCLAIMER

TI PROVIDES TECHNICAL AND RELIABILITY DATA (INCLUDING DATA SHEETS), DESIGN RESOURCES (INCLUDING REFERENCE DESIGNS), APPLICATION OR OTHER DESIGN ADVICE, WEB TOOLS, SAFETY INFORMATION, AND OTHER RESOURCES "AS IS" AND WITH ALL FAULTS, AND DISCLAIMS ALL WARRANTIES, EXPRESS AND IMPLIED, INCLUDING WITHOUT LIMITATION ANY IMPLIED WARRANTIES OF MERCHANTABILITY, FITNESS FOR A PARTICULAR PURPOSE OR NON-INFRINGEMENT OF THIRD PARTY INTELLECTUAL PROPERTY RIGHTS.

These resources are intended for skilled developers designing with TI products. You are solely responsible for (1) selecting the appropriate TI products for your application, (2) designing, validating and testing your application, and (3) ensuring your application meets applicable standards, and any other safety, security, regulatory or other requirements.

These resources are subject to change without notice. TI grants you permission to use these resources only for development of an application that uses the TI products described in the resource. Other reproduction and display of these resources is prohibited. No license is granted to any other TI intellectual property right or to any third party intellectual property right. TI disclaims responsibility for, and you will fully indemnify TI and its representatives against, any claims, damages, costs, losses, and liabilities arising out of your use of these resources.

TI's products are provided subject to [TI's Terms of Sale](#) or other applicable terms available either on [ti.com](https://www.ti.com) or provided in conjunction with such TI products. TI's provision of these resources does not expand or otherwise alter TI's applicable warranties or warranty disclaimers for TI products.

TI objects to and rejects any additional or different terms you may have proposed.

Mailing Address: Texas Instruments, Post Office Box 655303, Dallas, Texas 75265
Copyright © 2024, Texas Instruments Incorporated

Looking for pricing, stock, or lifecycle information?

Click below to explore more details on WIN SOURCE:

 [View SN65HVD07DR](#) on WIN SOURCE

 [Texas Instruments](#) Information

Optimize Your Supply Chain with WIN SOURCE Solutions

-  Global Sourcing Solution
-  Obsolete Management
-  Cost Control Management
-  Shortage Management
-  Alternative Solution
-  Excess Inventory Management