



THE DATASHEET OF SN65C3232PWR



3-V to 5.5-V Multichannel RS-232 Compatible Line Driver and Receiver

1 Features

- Operate with 3-V to 5.5-V V_{CC} supply
- Operate up to 1 Mbit/s
- Low supply current: 300 μ A typical
- External capacitors: $4 \times 0.1 \mu$ F
- Accept 5-V logic input with 3.3-V supply
- RS-232 bus-pin ESD protection exceeds ± 15 kV using human-body model (HBM)

2 Applications

- [Industrial PCs](#)
- [Wired networking](#)
- [Data center and enterprise computing](#)
- [Battery-powered systems](#)
- [Notebooks](#)
- [Laptops](#)
- [Palmtop PCs](#)
- [Hand-held equipment](#)

3 Description

The SN65C3232 and SN75C3232 consist of two line drivers, two line receivers, and a dual charge-pump circuit with ± 15 -kV ESD protection pin-to-pin (serial-port connection pins, including GND). These devices provide the electrical interface between an asynchronous communication controller and the serial-port connector. The charge pump and four small external capacitors allow operation from a single 3-V to 5.5-V supply. The devices operate at typical data signaling rates up to 1 Mbit/s and a driver output slew rate of 24 V/ μ s to 150 V/ μ s.

Device Information

PART NUMBER	PACKAGE ⁽¹⁾	BODY SIZE (NOM)
SN65C3232 SN75C3232	D (SOIC) (16)	9.90 mm x 3.91 mm
	DB (SSOP) (16)	6.20 mm x 5.30 mm
	DW (SOIC) (16)	10.3 mm x 7.50 mm
	PW (TSSOP) (16)	5.00 mm v 4.40 mm

(1) For all available packages, see the orderable addendum at the end of the data sheet.

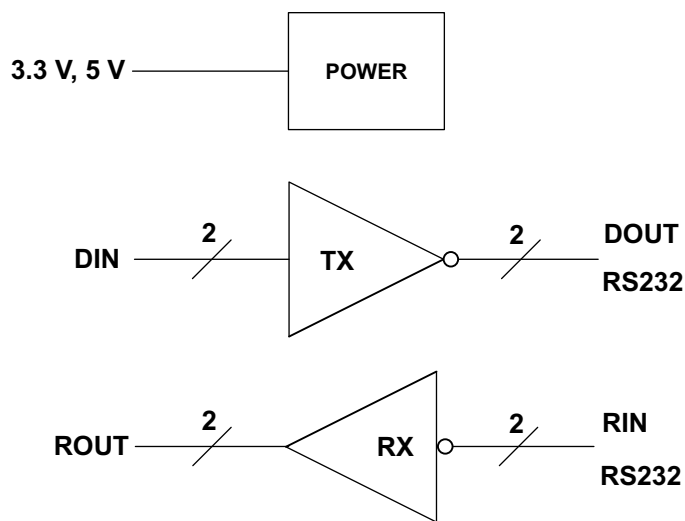

Simplified Diagram



Table of Contents

1 Features	1	8.1 Overview.....	10
2 Applications	1	8.2 Functional Block Diagram.....	10
3 Description	1	8.3 Feature Description.....	10
4 Revision History	2	8.4 Device Functional Modes.....	11
5 Pin Configuration and Functions	3	9 Application and Implementation	12
6 Specifications	4	9.1 Application Information.....	12
6.1 Absolute Maximum Ratings.....	4	10 Layout	14
6.2 ESD Ratings.....	4	10.1 Layout Guidelines.....	14
6.3 Recommended Operating Conditions.....	4	10.2 Layout Example.....	14
6.4 Thermal Information.....	5	11 Device and Documentation Support	15
6.5 Electrical Characteristics.....	5	11.1 Documentation Support.....	15
6.6 Driver Section - Electrical Characteristics.....	6	11.2 Receiving Notification of Documentation Updates..	15
6.7 Switching Characteristics.....	6	11.3 Support Resources.....	15
6.8 Receiver Section - Electrical Characteristics.....	7	11.4 Trademarks.....	15
6.9 Switching Characteristics.....	7	11.5 Electrostatic Discharge Caution.....	15
6.10 Typical Characteristics.....	8	11.6 Glossary.....	15
7 Parameter Measurement Information	9	12 Mechanical, Packaging, and Orderable Information	15
8 Detailed Description	10		

4 Revision History

NOTE: Page numbers for previous revisions may differ from page numbers in the current version.

Changes from Revision B (November 2004) to Revision C (June 2021)

Page

- Added *Device Information* table, *Pin Configuration and Functions* section, *ESD Ratings* table, *Feature Description* section, *Device Functional Modes*, *Application and Implementation* section, *Power Supply Recommendations* section, *Layout* section, *Device and Documentation Support* section, and *Mechanical, Packaging, and Orderable Information* section 1
- Added *Applications*: Industrial PCs, Wired networking, and Data center and enterprise computing..... 1
- Added thermal parameter values for all packages and changed the thermal parameters for D package in the *Thermal Information* table..... 5

5 Pin Configuration and Functions

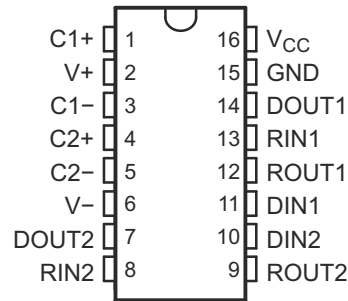

Figure 5-1. D, DW, DB and PW Package, 16-Pin SOIC, SSOP and TSSOP, Top View

PIN		I/O	DESCRIPTION
NAME	NO.		
C1+	1	—	Positive lead of C1 capacitor
V+	2	O	Positive charge pump output for storage capacitor only
C1-	3	—	Negative lead of C1 capacitor
C2+	4	—	Positive lead of C2 capacitor
C2-	5	—	Negative lead of C2 capacitor
V-	6	O	Negative charge pump output for storage capacitor only
DOUT2	7	O	RS232 line data output (to remote RS232 system)
RIN2	8	I	RS232 line data input (from remote RS232 system)
ROUT2	9	O	Logic data output (to UART)
DIN2	10	I	Logic data input (from UART)
DIN1	11	I	Logic data input (from UART)
ROUT1	12	O	Logic data output (to UART)
RIN1	13	I	RS232 line data input (from remote RS232 system)
DOUT1	14	O	RS232 line data output (to remote RS232 system)
GND	15	—	Ground
V _{CC}	16	—	Supply Voltage, Connect to external 3-V to 5.5-V power supply

6 Specifications

6.1 Absolute Maximum Ratings

over operating free-air temperature range (unless otherwise noted) ⁽¹⁾

		MIN	MAX	UNIT	
V _{CC}	Supply voltage range ⁽²⁾	-0.3	6	V	
V+	Positive-output supply voltage range ⁽²⁾	-0.3	7	V	
V-	Negative-output supply voltage range ⁽²⁾	0.3	-7	V	
V+ - V-	Supply voltage difference ⁽²⁾		13	V	
V _I	Input voltage range	Drivers	-0.3	6	V
		Receivers	-25	25	
V _O	Output voltage range	Drivers	-13.2	13.2	V
		Receivers	-0.3	V _{CC} + 0.3	
T _J	Operating virtual junction temperature		150	°C	
T _{stg}	Storage temperature range	-65	150	°C	

(1) Operation outside the Absolute Maximum Ratings may cause permanent device damage. Absolute Maximum Ratings do not imply functional operation of the device at these or any other conditions beyond those listed under Recommended Operating Conditions. If used outside the Recommended Operating Conditions but within the Absolute Maximum Ratings, the device may not be fully functional, and this may affect device reliability, functionality, performance, and shorten the device lifetime.

(2) All voltages are with respect to network GND.

6.2 ESD Ratings

			VALUE	UNIT	
V _(ESD)	Electrostatic discharge	Human body model (HBM), per ANSI/ESDA/JEDEC JS-001 ⁽¹⁾	All pins except RIN and DOUT	±3000	V
			RIN and DOUT Pins	±15,000	
		Charged-device model (CDM), per JEDEC specification JESD22-C101 ⁽²⁾	All pins	±1500	

(1) JEDEC document JEP155 states that 500-V HBM allows safe manufacturing with a standard ESD control process.

(2) JEDEC document JEP157 states that 250-V CDM allows safe manufacturing with a standard ESD control process.

6.3 Recommended Operating Conditions

See [Typical Operating Circuit and Capacitor Values](#), See ⁽¹⁾

		MIN	NOM	MAX	UNIT
Supply voltage	V _{CC} = 3.3 V	3	3.3	3.6	V
	V _{CC} = 5 V	4.5	5	5.5	
V _{IH}	Driver high-level input voltage	DIN	V _{CC} = 3.3 V	2	V
			V _{CC} = 5 V	2.4	
V _{IL}	Driver low-level input voltage	DIN		0.8	V
V _I	Driver input voltage	DIN	0	5.5	V
	Receiver input voltage		-25	25	
T _A	Operating free-air temperature	SN75C3232	0	70	°C
		SN65C3232	-40	85	

(1) Test conditions are C1–C4 = 0.1 μF at V_{CC} = 3.3 V ± 0.3 V; C1 = 0.047 μF, C2–C4 = 0.33 μF at V_{CC} = 5 V ± 0.5 V.

6.4 Thermal Information

THERMAL METRIC ⁽¹⁾		SN65C3232, SN75C3232				UNIT
		PW (TSSOP)	D (SOIC)	DW (SOIC)	DB (SSOP)	
		16 PINS	16 PINS	16 PINS	16 PINS	
R _{θJA}	Junction-to-ambient thermal resistance	108.0	85.9	57.0	46.0	°C/W
R _{θJCTop}	Junction-to-case (top) thermal resistance	20.8	43.1	33.5	36.2	°C/W
R _{θJB}	Junction-to-board thermal resistance	45.1	44.5	37.1	43.8	°C/W
Ψ _{JT}	Junction-to-top characterization parameter	0.6	10.1	7.5	4.2	°C/W
Ψ _{JB}	Junction-to-board characterization parameter	45.1	44.1	37.1	42.9	°C/W
R _{θJCbott}	Junction-to-case (bottom) thermal resistance	–	–	–	–	°C/W

(1) For more information about traditional and new thermal metrics, see the [Semiconductor and IC Package Thermal Metrics](#) application report.

6.5 Electrical Characteristics

over recommended ranges of supply voltage and operating free-air temperature (unless otherwise noted) (see [Typical Operating Circuit and Capacitor Values](#))

PARAMETER ⁽²⁾		TEST CONDITIONS	MIN	TYP ⁽¹⁾	MAX	UNIT
I _{CC}	Supply current	No load, V _{CC} = 3.3 V or 5 V		0.3	1	mA

(1) All typical values are at V_{CC} = 3.3 V or V_{CC} = 5 V, and T_A = 25°C.

(2) Test conditions are C1–C4 = 0.1 μF at V_{CC} = 3.3 V ± 0.3 V; C1 = 0.047 μF, C2–C4 = 0.33 μF at V_{CC} = 5 V ± 0.5 V.

6.6 Driver Section - Electrical Characteristics

over recommended ranges of supply voltage and operating free-air temperature (unless otherwise noted) (see [Typical Operating Circuit and Capacitor Values](#))

PARAMETER		TEST CONDITIONS ⁽³⁾		MIN	TYP ⁽¹⁾	MAX	UNIT
V _{OH}	High-level output voltage	DOUT at R _L = 3 kΩ to GND,	DIN = GND	5	5.4		V
V _{OL}	Low-level output voltage	DOUT at R _L = 3 kΩ to GND,	DIN = V _{CC}	-5	-5.4		V
I _{IH}	High-level input current	V _I = V _{CC}			±0.01	±1	μA
I _{IL}	Low-level input current	V _I at GND			±0.01	±1	μA
I _{OS}	Short-circuit output current ⁽²⁾	V _O = 0 V	V _{CC} = 3.6 V		±35	±60	mA
			V _{CC} = 5.5 V		±35	±90	
r _o	Output resistance	V _{CC} , V+, and V- = 0 V,	V _O = ±2 V	300	10M		Ω

(1) All typical values are at V_{CC} = 3.3 V or V_{CC} = 5 V, and T_A = 25°C.

(2) Short-circuit durations should be controlled to prevent exceeding the device absolute power dissipation ratings, and not more than one output should be shorted at a time.

(3) Test conditions are C1–C4 = 0.1 μF at V_{CC} = 3.3 V ± 0.3 V; C1 = 0.047 μF, C2–C4 = 0.33 μF at V_{CC} = 5 V ± 0.5 V.

6.7 Switching Characteristics

over recommended ranges of supply voltage and operating free-air temperature (unless otherwise noted) (see [Typical Operating Circuit and Capacitor Values](#))

PARAMETER		TEST CONDITIONS ⁽³⁾		MIN	TYP ⁽¹⁾	MAX	UNIT
Maximum data rate (see Figure 7-1)	R _L = 3 kΩ, One DOUT switching	C _L = 1000 pF		250			kbit/s
		C _L = 250 pF,	V _{CC} = 3 V to 4.5 V	1000			
		C _L = 1000 pF,	V _{CC} = 4.5 V to 5.5 V	1000			
t _{sk(p)}	Pulse skew ⁽²⁾	C _L = 150 pF to 2500 pF,	R _L = 3 kΩ to 7 kΩ, See Figure 7-2		300		ns
SR(tr)	Slew rate, transition region (see Figure 7-1)	R _L = 3 kΩ to 7 kΩ,	C _L = 150 pF to 1000 pF, V _{CC} = 3.3 V		18	150	V/μs

(1) All typical values are at V_{CC} = 3.3 V or V_{CC} = 5 V, and T_A = 25°C.

(2) Pulse skew is defined as |t_{PLH} - t_{PHL}| of each channel of the same device.

(3) Test conditions are C1–C4 = 0.1 μF at V_{CC} = 3.3 V ± 0.3 V; C1 = 0.047 μF, C2–C4 = 0.33 μF at V_{CC} = 5 V ± 0.5 V.

6.8 Receiver Section - Electrical Characteristics

over recommended ranges of supply voltage and operating free-air temperature (unless otherwise noted) (see [Typical Operating Circuit and Capacitor Values](#))

PARAMETER		TEST CONDITIONS ⁽²⁾	MIN	TYP ⁽¹⁾	MAX	UNIT
V _{OH}	High-level output voltage	I _{OH} = -1 mA	V _{CC} - 0.6	V _{CC} - 0.1		V
V _{OL}	Low-level output voltage	I _{OL} = 1.6 mA			0.4	V
V _{IT+}	Positive-going input threshold voltage	V _{CC} = 3.3 V		1.5	2.4	V
		V _{CC} = 5 V		1.8	2.4	
V _{IT-}	Negative-going input threshold voltage	V _{CC} = 3.3 V	0.6	1.2		V
		V _{CC} = 5 V	0.8	1.5		
V _{hys}	Input hysteresis (V _{IT+} - V _{IT-})			0.3		V
r _i	Input resistance	V _I = ±3 V to ±25 V	3	5	7	kΩ

(1) All typical values are at V_{CC} = 3.3 V or V_{CC} = 5 V, and T_A = 25°C.

(2) Test conditions are C1–C4 = 0.1 μF at V_{CC} = 3.3 V ± 0.3 V; C1 = 0.047 μF, C2–C4 = 0.33 μF at V_{CC} = 5 V ± 0.5 V.

6.9 Switching Characteristics

over recommended ranges of supply voltage and operating free-air temperature (unless otherwise noted) (see [Typical Operating Circuit and Capacitor Values](#))

PARAMETER		TEST CONDITIONS ⁽³⁾	TYP ⁽¹⁾	UNIT
t _{PLH}	Propagation delay time, low- to high-level output	C _L = 150 pF	300	ns
t _{PHL}	Propagation delay time, high- to low-level output	C _L = 150 pF	300	ns
t _{sk(p)}	Pulse skew ⁽²⁾		300	ns

(1) All typical values are at V_{CC} = 3.3 V or V_{CC} = 5 V, and T_A = 25°C.

(2) Pulse skew is defined as |t_{PLH} - t_{PHL}| of each channel of the same device.

(3) Test conditions are C1–C4 = 0.1 μF at V_{CC} = 3.3 V ± 0.3 V; C1 = 0.047 μF, C2–C4 = 0.33 μF at V_{CC} = 5 V ± 0.5 V.

6.10 Typical Characteristics

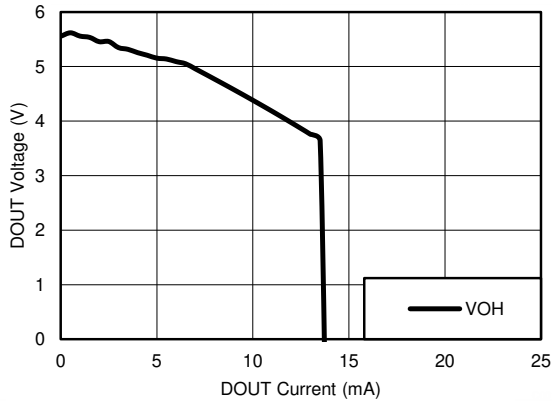

$V_{CC} = 3.3\text{ V}$

Figure 6-1. DOUT V_{OH} vs Load Current, Both Drivers Loaded

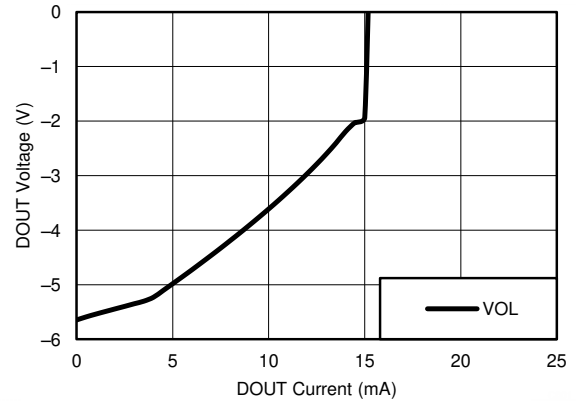

$V_{CC} = 3.3\text{ V}$

Figure 6-2. DOUT V_{OL} vs Load Current, Both Drivers Loaded

7 Parameter Measurement Information

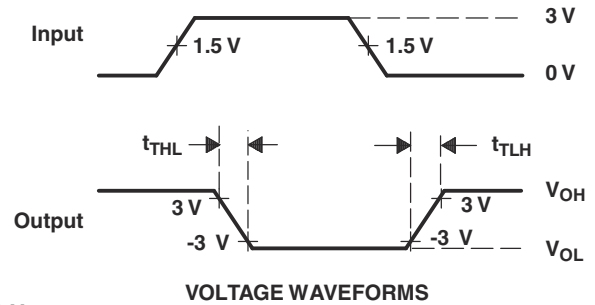
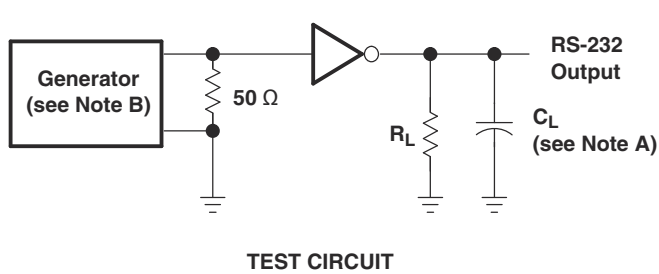

$$SR(tr) = \frac{6\text{ V}}{t_{THL} \text{ or } t_{TLH}}$$

- A. C_L includes probe and jig capacitance.
 B. The pulse generator has the following characteristics: PRR = 250 kbit/s, $Z_O = 50\ \Omega$, 50% duty cycle, $t_r \leq 10\text{ ns}$, $t_f \leq 10\text{ ns}$.

Figure 7-1. Driver Slew Rate

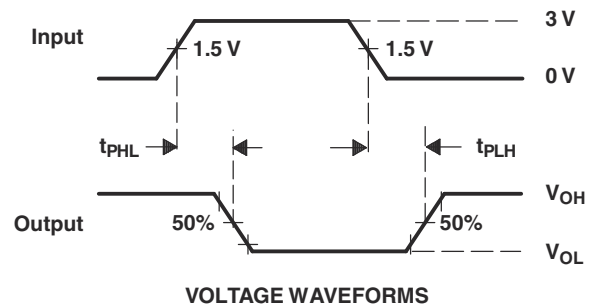
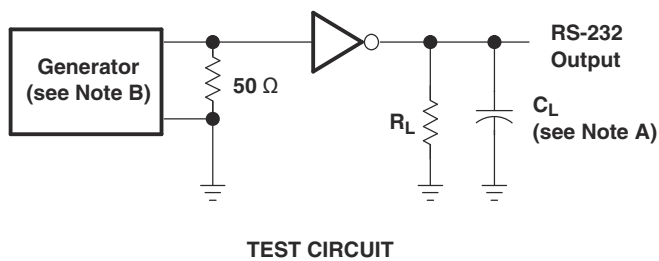

- A. C_L includes probe and jig capacitance.
 B. The pulse generator has the following characteristics: PRR = 250 kbit/s, $Z_O = 50\ \Omega$, 50% duty cycle, $t_r \leq 10\text{ ns}$, $t_f \leq 10\text{ ns}$.

Figure 7-2. Driver Pulse Skew

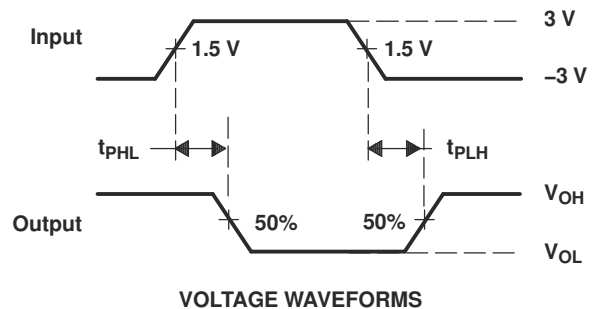
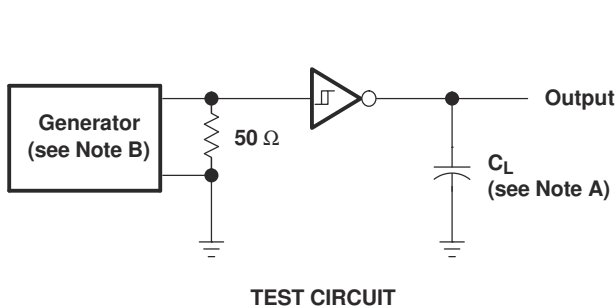

- A. C_L includes probe and jig capacitance.
 B. The pulse generator has the following characteristics: $Z_O = 50\ \Omega$, 50% duty cycle, $t_r \leq 10\text{ ns}$, $t_f \leq 10\text{ ns}$.

Figure 7-3. Receiver Propagation Delay Times

8 Detailed Description

8.1 Overview

The device consists of two line drivers, two-line receivers, and a dual charge-pump circuit with IEC61000-4-2 ESD protection terminal to terminal (serial-port connection terminals, including GND). The device meets the requirements of TIA/EIA-232-F and provides the electrical interface between an asynchronous communication controller and the serial-port connector. The charge pump and four small external capacitors allow operation from a single 3-V to 5.5-V supply. The device operates at data signaling rates up to 250 kbit/s and a maximum of 30-V/ μ s driver output slew rate. Outputs are protected against shorts to ground.

8.2 Functional Block Diagram

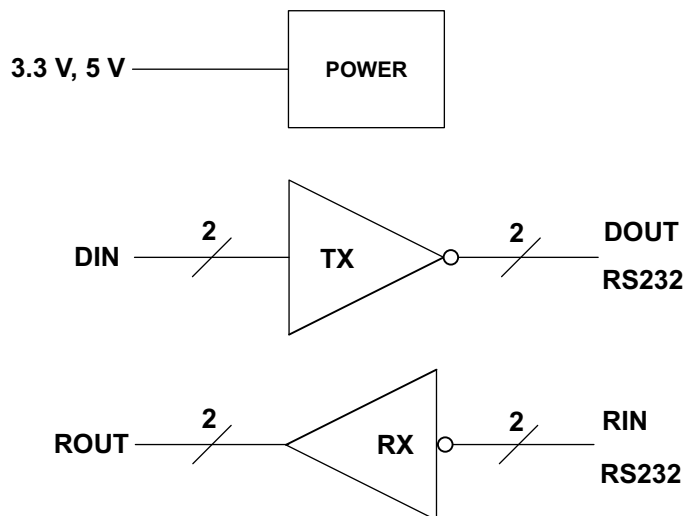

8.3 Feature Description

8.3.1 Power

The power block increases, inverts, and regulates voltage at V+ and V– pins using a charge pump that requires four external capacitors.

8.3.2 RS232 Driver

Two drivers interface standard logic level to RS232 levels. Both DIN inputs must be valid high or low.

8.3.3 RS232 Receiver

Two receivers interface RS232 levels to standard logic levels. An open input will result in a high output on ROUT. Each RIN input includes an internal standard RS232 load.

8.4 Device Functional Modes

Table 8-1 and Table 8-2 list the functional modes of the drivers and receivers of MAX3232E.

Table 8-1. Each Driver⁽¹⁾

INPUT DIN	OUTPUT DOUT
L	H
H	L

(1) H = high level, L = low level

Table 8-2. Each Receiver⁽¹⁾

INPUT RIN	OUTPUT ROUT
L	H
H	L
Open	H

(1) H = high level, L = low level,
Open = input disconnected or connected driver off

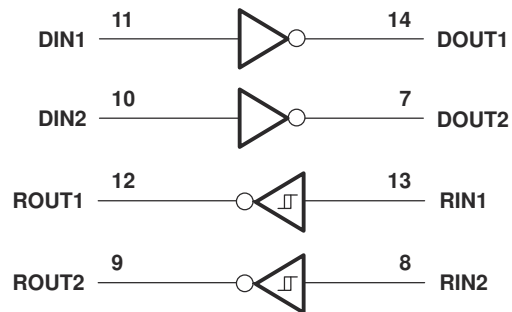

Figure 8-1. Logic Diagram

8.4.1 V_{CC} Powered by 3 V to 5.5 V

The device is in normal operation.

8.4.2 V_{CC} Unpowered, V_{CC} = 0 V

When the device is unpowered, it can be safely connected to an active remote RS232 device.

9 Application and Implementation

Note

Information in the following applications sections is not part of the TI component specification, and TI does not warrant its accuracy or completeness. TI's customers are responsible for determining suitability of components for their purposes, as well as validating and testing their design implementation to confirm system functionality.

9.1 Application Information

For proper operation, add capacitors as shown in [Table 9-1](#).

9.1.1 Typical Application

ROUT and DIN connect to UART or general-purpose logic lines. RIN and DOUT lines connect to a RS232 connector or cable.

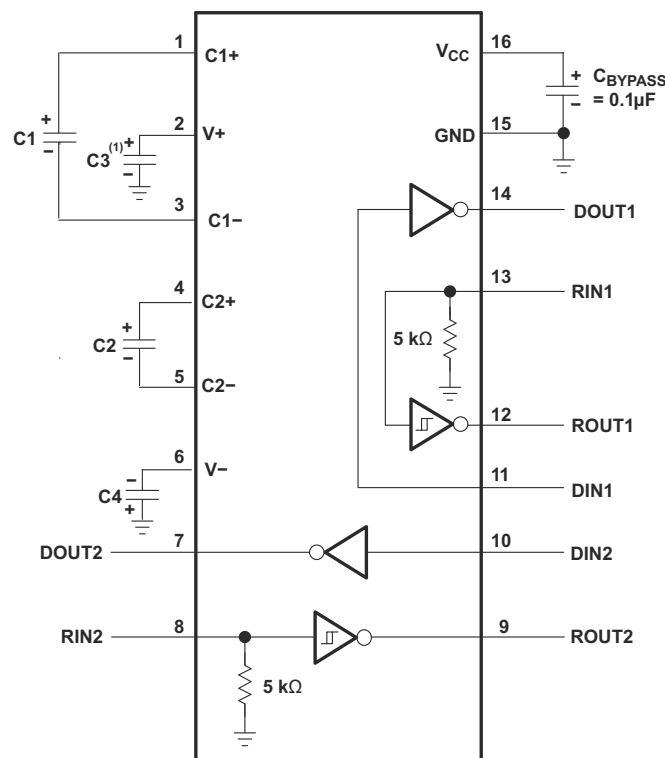

- A. C3 can be connected to V_{CC} or GND
- A. Resistor values shown are nominal.
- B. Nonpolarized ceramic capacitors are acceptable. If polarized tantalum or electrolytic capacitors are used, they should be connected as shown.

Figure 9-1. Typical Operating Circuit and Capacitor Values

Table 9-1. VCC vs Capacitor Values

V_{CC}	C1	C2, C3, C4
3.3 V \pm 0.3 V	0.1 μ F	0.1 μ F
5 V \pm 0.5 V	0.047 μ F	0.33 μ F
3 V to 5.5 V	0.1 μ F	0.47 μ F

9.1.1.1 Design Requirements

The recommended V_{CC} is 3.3 V or 5 V. 3 V to 5.5 V is also possible

The maximum recommended bit rate is 250 kbit/s.

9.1.1.2 Detailed Design Procedure

All DIN inputs must be connected to valid low or high logic levels.

Select capacitor values based on V_{CC} level for best performance.

9.1.1.3 Application Performance Plots

Figure 9-2 curves are for 3.3-V V_{CC} and 250-kbit/s alternative bit data stream.

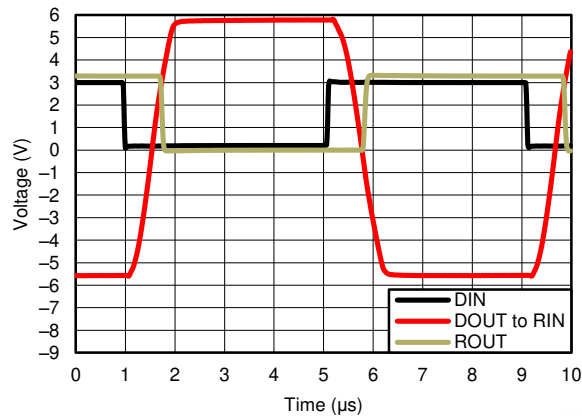

Figure 9-2. 250 kbit/s Driver to Receiver Loopback Timing Waveform, $V_{CC} = 3.3$ V

10 Layout

10.1 Layout Guidelines

Keep the external capacitor traces short, specifically on the C1 and C2 nodes that have the fastest rise and fall times.

10.2 Layout Example

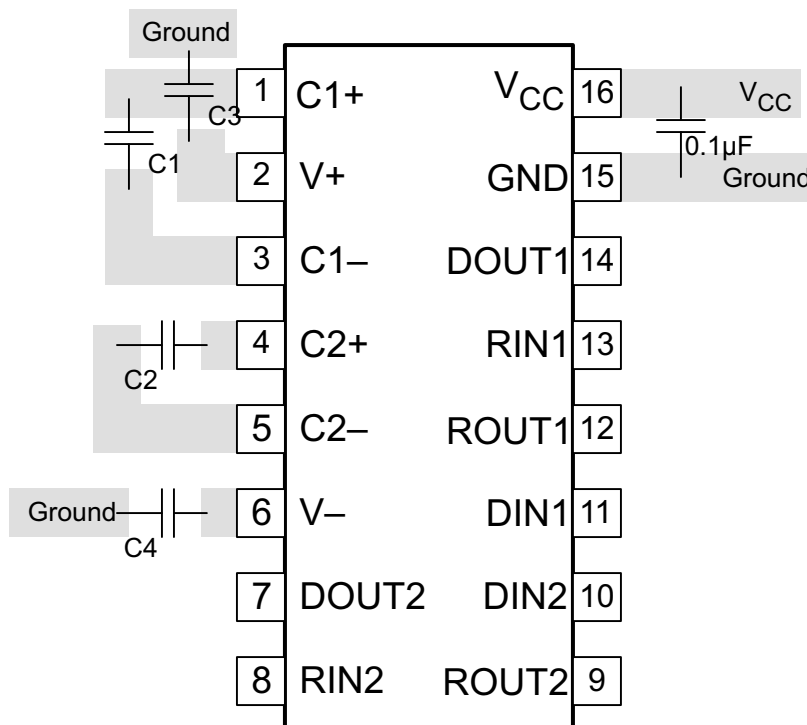

Figure 10-1. Layout Diagram

11 Device and Documentation Support

TI offers an extensive line of development tools. Tools and software to evaluate the performance of the device, generate code, and develop solutions are listed below.

11.1 Documentation Support

11.1.1 Related Documentation

11.1.1.1 Related Links

The table below lists quick access links. Categories include technical documents, support and community resources, tools and software, and quick access to order now.

11.2 Receiving Notification of Documentation Updates

To receive notification of documentation updates, navigate to the device product folder on ti.com. Click on *Subscribe to updates* to register and receive a weekly digest of any product information that has changed. For change details, review the revision history included in any revised document.

11.3 Support Resources

[TI E2E™ support forums](#) are an engineer's go-to source for fast, verified answers and design help — straight from the experts. Search existing answers or ask your own question to get the quick design help you need.

Linked content is provided "AS IS" by the respective contributors. They do not constitute TI specifications and do not necessarily reflect TI's views; see TI's [Terms of Use](#).

11.4 Trademarks

TI E2E™ is a trademark of Texas Instruments.

All trademarks are the property of their respective owners.

11.5 Electrostatic Discharge Caution



This integrated circuit can be damaged by ESD. Texas Instruments recommends that all integrated circuits be handled with appropriate precautions. Failure to observe proper handling and installation procedures can cause damage.

ESD damage can range from subtle performance degradation to complete device failure. Precision integrated circuits may be more susceptible to damage because very small parametric changes could cause the device not to meet its published specifications.

11.6 Glossary

[TI Glossary](#) This glossary lists and explains terms, acronyms, and definitions.

12 Mechanical, Packaging, and Orderable Information

The following pages include mechanical, packaging, and orderable information. This information is the most current data available for the designated devices. This data is subject to change without notice and revision of this document. For browser-based versions of this data sheet, refer to the left-hand navigation.

PACKAGING INFORMATION

Orderable Device	Status (1)	Package Type	Package Drawing	Pins	Package Qty	Eco Plan (2)	Lead finish/ Ball material (6)	MSL Peak Temp (3)	Op Temp (°C)	Device Marking (4/5)	Samples
SN65C3232DBR	ACTIVE	SSOP	DB	16	2000	RoHS & Green	NIPDAU	Level-1-260C-UNLIM	-40 to 85	65C3232	Samples
SN65C3232DR	ACTIVE	SOIC	D	16	2500	RoHS & Green	NIPDAU	Level-1-260C-UNLIM	-40 to 85	65C3232	Samples
SN65C3232DW	ACTIVE	SOIC	DW	16	40	RoHS & Green	NIPDAU	Level-1-260C-UNLIM	-40 to 85	65C3232	Samples
SN65C3232DWR	ACTIVE	SOIC	DW	16	2000	RoHS & Green	NIPDAU	Level-1-260C-UNLIM	-40 to 85	65C3232	Samples
SN65C3232PWR	ACTIVE	TSSOP	PW	16	2000	RoHS & Green	NIPDAU	Level-1-260C-UNLIM	-40 to 85	CB3232	Samples
SN75C3232DBR	ACTIVE	SSOP	DB	16	2000	RoHS & Green	NIPDAU	Level-1-260C-UNLIM	0 to 70	CA3232	Samples
SN75C3232DR	ACTIVE	SOIC	D	16	2500	RoHS & Green	NIPDAU	Level-1-260C-UNLIM	0 to 70	75C3232	Samples
SN75C3232DW	ACTIVE	SOIC	DW	16	40	RoHS & Green	NIPDAU	Level-1-260C-UNLIM	0 to 70	75C3232	Samples
SN75C3232DWR	ACTIVE	SOIC	DW	16	2000	RoHS & Green	NIPDAU	Level-1-260C-UNLIM	0 to 70	75C3232	Samples

(1) The marketing status values are defined as follows:

ACTIVE: Product device recommended for new designs.

LIFEBUY: TI has announced that the device will be discontinued, and a lifetime-buy period is in effect.

NRND: Not recommended for new designs. Device is in production to support existing customers, but TI does not recommend using this part in a new design.

PREVIEW: Device has been announced but is not in production. Samples may or may not be available.

OBSELETE: TI has discontinued the production of the device.

(2) **RoHS:** TI defines "RoHS" to mean semiconductor products that are compliant with the current EU RoHS requirements for all 10 RoHS substances, including the requirement that RoHS substance do not exceed 0.1% by weight in homogeneous materials. Where designed to be soldered at high temperatures, "RoHS" products are suitable for use in specified lead-free processes. TI may reference these types of products as "Pb-Free".

RoHS Exempt: TI defines "RoHS Exempt" to mean products that contain lead but are compliant with EU RoHS pursuant to a specific EU RoHS exemption.

Green: TI defines "Green" to mean the content of Chlorine (Cl) and Bromine (Br) based flame retardants meet JS709B low halogen requirements of <=1000ppm threshold. Antimony trioxide based flame retardants must also meet the <=1000ppm threshold requirement.

(3) MSL, Peak Temp. - The Moisture Sensitivity Level rating according to the JEDEC industry standard classifications, and peak solder temperature.

(4) There may be additional marking, which relates to the logo, the lot trace code information, or the environmental category on the device.

⁽⁵⁾ Multiple Device Markings will be inside parentheses. Only one Device Marking contained in parentheses and separated by a "~" will appear on a device. If a line is indented then it is a continuation of the previous line and the two combined represent the entire Device Marking for that device.

⁽⁶⁾ Lead finish/Ball material - Orderable Devices may have multiple material finish options. Finish options are separated by a vertical ruled line. Lead finish/Ball material values may wrap to two lines if the finish value exceeds the maximum column width.

Important Information and Disclaimer:The information provided on this page represents TI's knowledge and belief as of the date that it is provided. TI bases its knowledge and belief on information provided by third parties, and makes no representation or warranty as to the accuracy of such information. Efforts are underway to better integrate information from third parties. TI has taken and continues to take reasonable steps to provide representative and accurate information but may not have conducted destructive testing or chemical analysis on incoming materials and chemicals. TI and TI suppliers consider certain information to be proprietary, and thus CAS numbers and other limited information may not be available for release.

In no event shall TI's liability arising out of such information exceed the total purchase price of the TI part(s) at issue in this document sold by TI to Customer on an annual basis.

TAPE AND REEL INFORMATION

QUADRANT ASSIGNMENTS FOR PIN 1 ORIENTATION IN TAPE

*All dimensions are nominal

Device	Package Type	Package Drawing	Pins	SPQ	Reel Diameter (mm)	Reel Width W1 (mm)	A0 (mm)	B0 (mm)	K0 (mm)	P1 (mm)	W (mm)	Pin1 Quadrant
SN65C3232DBR	SSOP	DB	16	2000	330.0	16.4	8.35	6.6	2.4	12.0	16.0	Q1
SN65C3232DR	SOIC	D	16	2500	330.0	16.4	6.5	10.3	2.1	8.0	16.0	Q1
SN65C3232DWR	SOIC	DW	16	2000	330.0	16.4	10.75	10.7	2.7	12.0	16.0	Q1
SN65C3232PWR	TSSOP	PW	16	2000	330.0	12.4	6.9	5.6	1.6	8.0	12.0	Q1
SN65C3232PWR	TSSOP	PW	16	2000	330.0	12.4	6.9	5.6	1.6	8.0	12.0	Q1
SN75C3232DBR	SSOP	DB	16	2000	330.0	16.4	8.35	6.6	2.4	12.0	16.0	Q1
SN75C3232DR	SOIC	D	16	2500	330.0	16.4	6.5	10.3	2.1	8.0	16.0	Q1
SN75C3232DWR	SOIC	DW	16	2000	330.0	16.4	10.75	10.7	2.7	12.0	16.0	Q1

TAPE AND REEL BOX DIMENSIONS



*All dimensions are nominal

Device	Package Type	Package Drawing	Pins	SPQ	Length (mm)	Width (mm)	Height (mm)
SN65C3232DBR	SSOP	DB	16	2000	356.0	356.0	35.0
SN65C3232DR	SOIC	D	16	2500	356.0	356.0	35.0
SN65C3232DWR	SOIC	DW	16	2000	350.0	350.0	43.0
SN65C3232PWR	TSSOP	PW	16	2000	356.0	356.0	35.0
SN65C3232PWR	TSSOP	PW	16	2000	356.0	356.0	35.0
SN75C3232DBR	SSOP	DB	16	2000	356.0	356.0	35.0
SN75C3232DR	SOIC	D	16	2500	356.0	356.0	35.0
SN75C3232DWR	SOIC	DW	16	2000	350.0	350.0	43.0

TUBE

*All dimensions are nominal

Device	Package Name	Package Type	Pins	SPQ	L (mm)	W (mm)	T (μm)	B (mm)
SN65C3232DW	DW	SOIC	16	40	506.98	12.7	4826	6.6
SN75C3232DW	DW	SOIC	16	40	506.98	12.7	4826	6.6

D (R-PDSO-G16)

PLASTIC SMALL OUTLINE



4040047-6/M 06/11

- NOTES:
- A. All linear dimensions are in inches (millimeters).
 - B. This drawing is subject to change without notice.
 - C. Body length does not include mold flash, protrusions, or gate burrs. Mold flash, protrusions, or gate burrs shall not exceed 0.006 (0,15) each side.
 - D. Body width does not include interlead flash. Interlead flash shall not exceed 0.017 (0,43) each side.
 - E. Reference JEDEC MS-012 variation AC.



4220204/A 02/2017

NOTES:

1. All linear dimensions are in millimeters. Any dimensions in parenthesis are for reference only. Dimensioning and tolerancing per ASME Y14.5M.
2. This drawing is subject to change without notice.
3. This dimension does not include mold flash, protrusions, or gate burrs. Mold flash, protrusions, or gate burrs shall not exceed 0.15 mm per side.
4. This dimension does not include interlead flash. Interlead flash shall not exceed 0.25 mm per side.
5. Reference JEDEC registration MO-153.

EXAMPLE BOARD LAYOUT

PW0016A

TSSOP - 1.2 mm max height

SMALL OUTLINE PACKAGE



LAND PATTERN EXAMPLE
EXPOSED METAL SHOWN
SCALE: 10X



SOLDER MASK DETAILS

4220204/A 02/2017

NOTES: (continued)

- 6. Publication IPC-7351 may have alternate designs.
- 7. Solder mask tolerances between and around signal pads can vary based on board fabrication site.

EXAMPLE STENCIL DESIGN

PW0016A

TSSOP - 1.2 mm max height

SMALL OUTLINE PACKAGE



SOLDER PASTE EXAMPLE
BASED ON 0.125 mm THICK STENCIL
SCALE: 10X

4220204/A 02/2017

NOTES: (continued)

8. Laser cutting apertures with trapezoidal walls and rounded corners may offer better paste release. IPC-7525 may have alternate design recommendations.
9. Board assembly site may have different recommendations for stencil design.

DB0016A



PACKAGE OUTLINE

SSOP - 2 mm max height

SMALL OUTLINE PACKAGE



4220763/A 05/2022

NOTES:

1. All linear dimensions are in millimeters. Any dimensions in parenthesis are for reference only. Dimensioning and tolerancing per ASME Y14.5M.
2. This drawing is subject to change without notice.
3. This dimension does not include mold flash, protrusions, or gate burrs. Mold flash, protrusions, or gate burrs shall not exceed 0.15 mm per side.
4. Reference JEDEC registration MO-150.

EXAMPLE BOARD LAYOUT

DB0016A

SSOP - 2 mm max height

SMALL OUTLINE PACKAGE



LAND PATTERN EXAMPLE
EXPOSED METAL SHOWN
SCALE: 10X



4220763/A 05/2022

NOTES: (continued)

5. Publication IPC-7351 may have alternate designs.
6. Solder mask tolerances between and around signal pads can vary based on board fabrication site.

EXAMPLE STENCIL DESIGN

DB0016A

SSOP - 2 mm max height

SMALL OUTLINE PACKAGE



SOLDER PASTE EXAMPLE
BASED ON 0.125 mm THICK STENCIL
SCALE: 10X

4220763/A 05/2022

NOTES: (continued)

7. Laser cutting apertures with trapezoidal walls and rounded corners may offer better paste release. IPC-7525 may have alternate design recommendations.
8. Board assembly site may have different recommendations for stencil design.

GENERIC PACKAGE VIEW

DW 16

SOIC - 2.65 mm max height

7.5 x 10.3, 1.27 mm pitch

SMALL OUTLINE INTEGRATED CIRCUIT

This image is a representation of the package family, actual package may vary.
Refer to the product data sheet for package details.

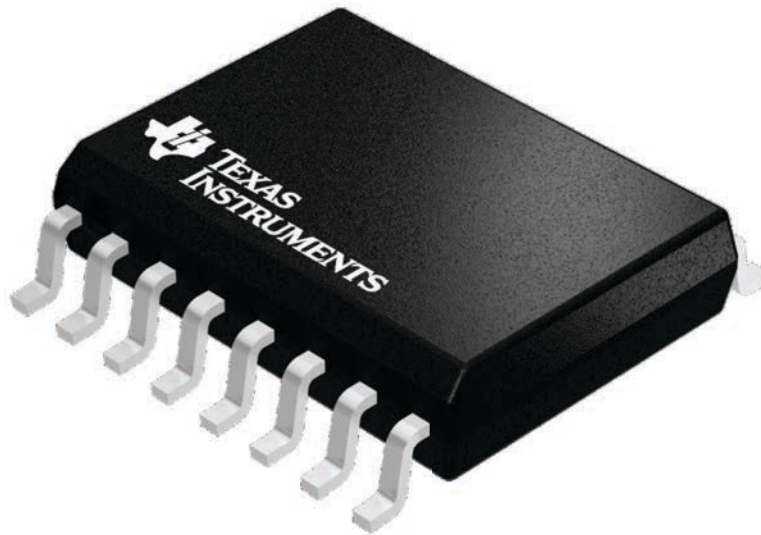

4224780/A



DW0016A

PACKAGE OUTLINE SOIC - 2.65 mm max height

SOIC

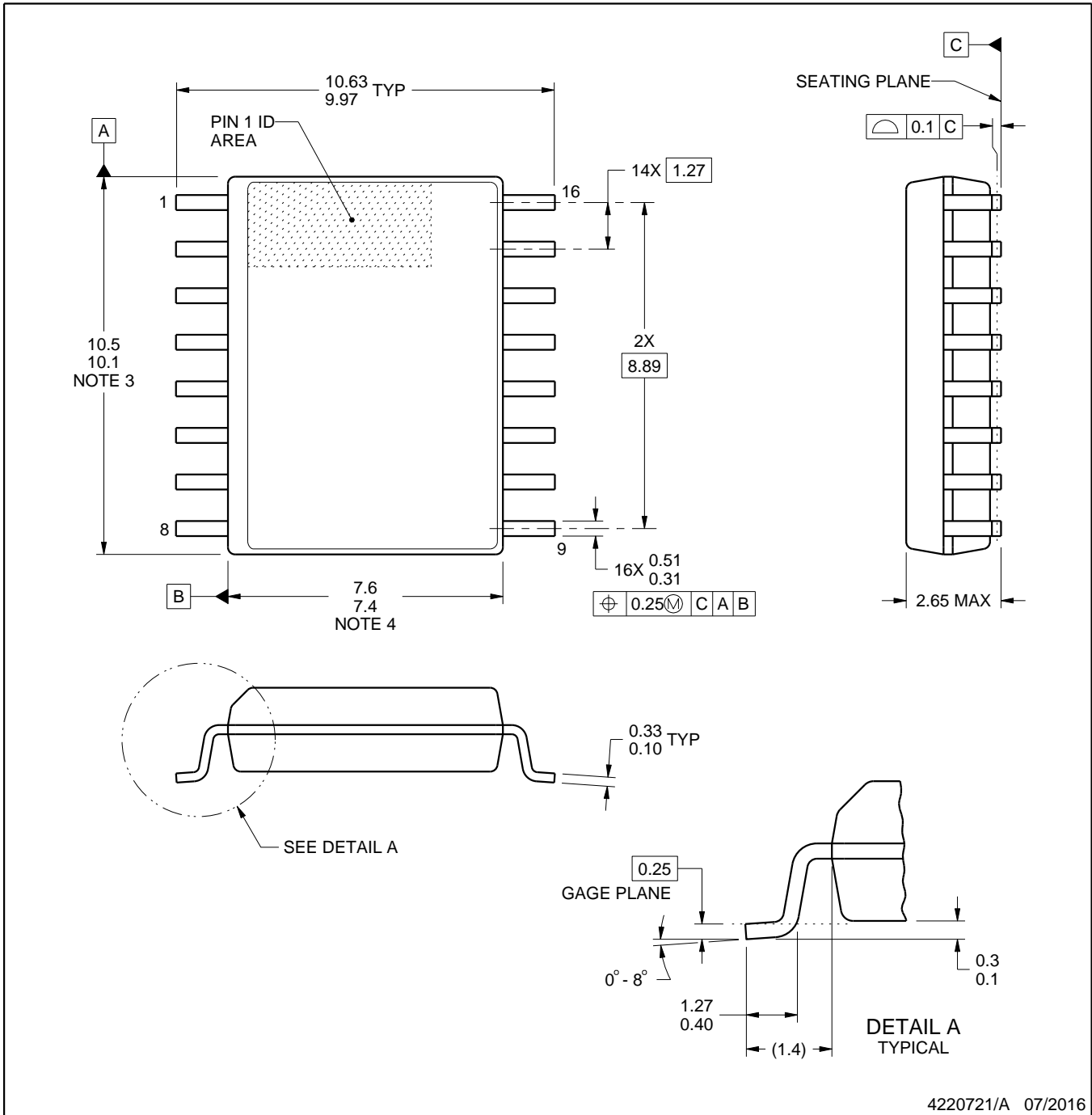

4220721/A 07/2016

NOTES:

1. All linear dimensions are in millimeters. Dimensions in parenthesis are for reference only. Dimensioning and tolerancing per ASME Y14.5M.
2. This drawing is subject to change without notice.
3. This dimension does not include mold flash, protrusions, or gate burrs. Mold flash, protrusions, or gate burrs shall not exceed 0.15 mm, per side.
4. This dimension does not include interlead flash. Interlead flash shall not exceed 0.25 mm, per side.
5. Reference JEDEC registration MS-013.

EXAMPLE BOARD LAYOUT

DW0016A

SOIC - 2.65 mm max height

SOIC



LAND PATTERN EXAMPLE
SCALE:7X



SOLDER MASK DETAILS

4220721/A 07/2016

NOTES: (continued)

6. Publication IPC-7351 may have alternate designs.

7. Solder mask tolerances between and around signal pads can vary based on board fabrication site.

EXAMPLE STENCIL DESIGN

DW0016A

SOIC - 2.65 mm max height

SOIC



SOLDER PASTE EXAMPLE
BASED ON 0.125 mm THICK STENCIL
SCALE:7X

4220721/A 07/2016

NOTES: (continued)

8. Laser cutting apertures with trapezoidal walls and rounded corners may offer better paste release. IPC-7525 may have alternate design recommendations.
9. Board assembly site may have different recommendations for stencil design.

IMPORTANT NOTICE AND DISCLAIMER

TI PROVIDES TECHNICAL AND RELIABILITY DATA (INCLUDING DATA SHEETS), DESIGN RESOURCES (INCLUDING REFERENCE DESIGNS), APPLICATION OR OTHER DESIGN ADVICE, WEB TOOLS, SAFETY INFORMATION, AND OTHER RESOURCES "AS IS" AND WITH ALL FAULTS, AND DISCLAIMS ALL WARRANTIES, EXPRESS AND IMPLIED, INCLUDING WITHOUT LIMITATION ANY IMPLIED WARRANTIES OF MERCHANTABILITY, FITNESS FOR A PARTICULAR PURPOSE OR NON-INFRINGEMENT OF THIRD PARTY INTELLECTUAL PROPERTY RIGHTS.

These resources are intended for skilled developers designing with TI products. You are solely responsible for (1) selecting the appropriate TI products for your application, (2) designing, validating and testing your application, and (3) ensuring your application meets applicable standards, and any other safety, security, regulatory or other requirements.

These resources are subject to change without notice. TI grants you permission to use these resources only for development of an application that uses the TI products described in the resource. Other reproduction and display of these resources is prohibited. No license is granted to any other TI intellectual property right or to any third party intellectual property right. TI disclaims responsibility for, and you will fully indemnify TI and its representatives against, any claims, damages, costs, losses, and liabilities arising out of your use of these resources.

TI's products are provided subject to [TI's Terms of Sale](#) or other applicable terms available either on [ti.com](https://www.ti.com) or provided in conjunction with such TI products. TI's provision of these resources does not expand or otherwise alter TI's applicable warranties or warranty disclaimers for TI products.

TI objects to and rejects any additional or different terms you may have proposed.

Mailing Address: Texas Instruments, Post Office Box 655303, Dallas, Texas 75265
Copyright © 2024, Texas Instruments Incorporated

Looking for pricing, stock, or lifecycle information?

Click below to explore more details on WIN SOURCE:

 [View SN65C3232PWR on WIN SOURCE](#)

 [Texas Instruments](#) Information

Optimize Your Supply Chain with WIN SOURCE Solutions

-  Global Sourcing Solution
-  Obsolete Management
-  Cost Control Management
-  Shortage Management
-  Alternative Solution
-  Excess Inventory Management