



**THE DATASHEET OF
SN65C3221PWR**



SN65C3221, SN75C3221

3-V TO 5.5-V SINGLE-CHANNEL RS-232 COMPATIBLE LINE DRIVER/RECEIVER

SLLS351E – APRIL 2002 – REVISED OCTOBER 2004

- Operate With 3-V to 5.5-V V_{CC} Supply
- Operate Up To 1 Mbit/s
- Low Standby Current . . . 1 μ A Typ
- External Capacitors . . . $4 \times 0.1 \mu$ F
- Accepts 5-V Logic Input With 3.3-V Supply
- RS-232 Bus-Pin ESD Protection Exceeds ± 15 kV Using Human-Body Model (HBM)
- Auto-Powerdown Feature Automatically Disables Drivers for Power Savings
- Applications
 - Battery-Powered, Hand-Held, and Portable Equipment
 - PDAs and Palmtop PCs
 - Notebooks, Sub-Notebooks, and Laptops
 - Digital Cameras
 - Mobile Phones and Wireless Devices

DB OR PW PACKAGE
(TOP VIEW)

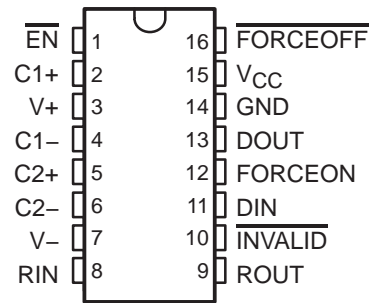

description/ordering information

The SN65C3221 and SN75C3221 consist of one line driver, one line receiver, and a dual charge-pump circuit with ± 15 -kV ESD protection pin to pin (serial-port connection pins, including GND). These devices provide the electrical interface between an asynchronous communication controller and the serial-port connector. The charge pump and four small external capacitors allow operation from a single 3-V to 5.5-V supply. These devices operate at data signaling rates up to 1 Mbit/s and a driver output slew rate of 24 V/ μ s to 150 V/ μ s.

Flexible control options for power management are available when the serial port is inactive. The auto-powerdown feature functions when FORCEON is low and FORCEOFF is high. During this mode of operation, if the devices do not sense a valid RS-232 signal on the receiver input, the driver output is disabled. If FORCEOFF is set low and EN is high, both the driver and receiver are shut off, and the supply current is reduced to 1 μ A. Disconnecting the serial port or turning off the peripheral drivers causes the auto-powerdown condition to occur. Auto-powerdown can be disabled when FORCEON and FORCEOFF are high. With auto-powerdown enabled, the device is activated automatically when a valid signal is applied to the receiver input. The INVALID output notifies the user if an RS-232 signal is present at the receiver input. INVALID is high (valid data) if the receiver input voltage is greater than 2.7 V or less than -2.7 V, or has been between -0.3 V and 0.3 V for less than 30 μ s. INVALID is low (invalid data) if the receiver input voltage is between -0.3 V and 0.3 V for more than 30 μ s. Refer to Figure 5 for receiver input levels.

ORDERING INFORMATION

T _A	PACKAGE†		ORDERABLE PART NUMBER	TOP-SIDE MARKING
-0°C to 70°C	SSOP (DB)	Reel of 2000	SN75C3221DBR	CA3221
	TSSOP (PW)	Tube of 90	SN75C3221PW	CA3221
		Reel of 2000	SN75C3221PWR	
-40°C to 85°C	SSOP (DB)	Reel of 2000	SN65C3221DBR	CB3221
	TSSOP (PW)	Tube of 90	SN65C3221PW	CB3221
		Reel of 2000	SN65C3221PWR	

† Package drawings, standard packing quantities, thermal data, symbolization, and PCB design guidelines are available at www.ti.com/sc/package.



Please be aware that an important notice concerning availability, standard warranty, and use in critical applications of Texas Instruments semiconductor products and disclaimers thereto appears at the end of this data sheet.

PRODUCTION DATA information is current as of publication date. Products conform to specifications per the terms of Texas Instruments standard warranty. Production processing does not necessarily include testing of all parameters.

**TEXAS
INSTRUMENTS**

POST OFFICE BOX 655303 • DALLAS, TEXAS 75265

Copyright © 2004, Texas Instruments Incorporated

SN65C3221, SN75C3221 3-V TO 5.5-V SINGLE-CHANNEL RS-232 COMPATIBLE LINE DRIVER/RECEIVER

SLLS351E – APRIL 2002 – REVISED OCTOBER 2004

Function Tables

EACH DRIVER

INPUTS			VALID RIN RS-232 LEVEL	OUTPUT DOUT	DRIVER STATUS
DIN	FORCEON	FORCEOFF			
X	X	L	X	Z	Powered off
L	H	H	X	H	Normal operation with auto-powerdown disabled
H	H	H	X	L	
L	L	H	Yes	H	Normal operation with auto-powerdown enabled
H	L	H	Yes	L	
L	L	H	No	Z	Powered off by auto-powerdown feature
H	L	H	No	Z	

H = high level, L = low level, X = irrelevant, Z = high impedance

EACH RECEIVER

INPUTS			VALID RIN RS-232 LEVEL	OUTPUT ROUT
RIN	EN			
L	L		X	H
H	L		X	L
X	H		X	Z
Open	L		No	H

H = high level, L = low level, X = irrelevant,
Z = high impedance (off), Open = disconnected
input or connected driver off

logic diagram (positive logic)

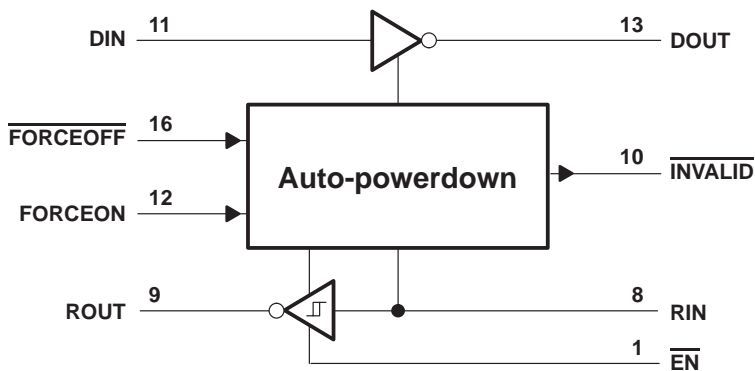

SN65C3221, SN75C3221

3-V TO 5.5-V SINGLE-CHANNEL RS-232 COMPATIBLE LINE DRIVER/RECEIVER

SLLS351E – APRIL 2002 – REVISED OCTOBER 2004

absolute maximum ratings over operating free-air temperature range (unless otherwise noted)†

Supply voltage range, V_{CC} (see Note 1)	–0.3 V to 6 V
Positive output supply voltage range, $V+$ (see Note 1)	–0.3 V to 7 V
Negative output supply voltage range, $V-$ (see Note 1)	0.3 V to –7 V
Supply voltage difference, $V+ - V-$ (see Note 1)	13 V
Input voltage range, V_I : Driver ($\overline{\text{FORCEOFF}}$, FORCEON , $\overline{\text{EN}}$)	–0.3 V to 6 V
Receiver	–25 V to 25 V
Output voltage range, V_O : Driver	–13.2 V to 13.2 V
Receiver ($\overline{\text{INVALID}}$)	–0.3 V to $V_{CC} + 0.3$ V
Package thermal impedance, θ_{JA} (see Notes 2 and 3): DB package	82°C/W
PW package	108°C/W
Operating virtual junction temperature, T_J	150°C
Storage temperature range, T_{stg}	–65°C to 150°C

† Stresses beyond those listed under “absolute maximum ratings” may cause permanent damage to the device. These are stress ratings only, and functional operation of the device at these or any other conditions beyond those indicated under “recommended operating conditions” is not implied. Exposure to absolute-maximum-rated conditions for extended periods may affect device reliability.

- NOTES:
- All voltages are with respect to network GND.
 - Maximum power dissipation is a function of $T_J(\text{max})$, θ_{JA} , and T_A . The maximum allowable power dissipation at any allowable ambient temperature is $P_D = (T_J(\text{max}) - T_A)/\theta_{JA}$. Operating at the absolute maximum T_J of 150°C can affect reliability.
 - The package thermal impedance is calculated in accordance with JESD 51-7.

recommended operating conditions (see Note 4 and Figure 6)

			MIN	NOM	MAX	UNIT
Supply voltage		$V_{CC} = 3.3$ V	3	3.3	3.6	V
		$V_{CC} = 5$ V	4.5	5	5.5	
V_{IH} Driver and control high-level input voltage	DIN, $\overline{\text{FORCEOFF}}$, FORCEON , $\overline{\text{EN}}$	$V_{CC} = 3.3$ V	2		V	
		$V_{CC} = 5$ V	2.4			
V_{IL} Driver and control low-level input voltage	DIN, $\overline{\text{FORCEOFF}}$, FORCEON , $\overline{\text{EN}}$			0.8	V	
V_I Driver and control input voltage	DIN, $\overline{\text{FORCEOFF}}$, FORCEON	0			5.5	V
V_I Receiver input voltage		–25			25	V
T_A Operating free-air temperature	SN65C3221	–40			85	°C
	SN75C3221	0			70	

NOTE 4: Test conditions are C1–C4 = 0.1 μ F at $V_{CC} = 3.3$ V \pm 0.3 V; C1 = 0.047 μ F, C2–C4 = 0.33 μ F at $V_{CC} = 5$ V \pm 0.5 V.

electrical characteristics over recommended ranges of supply voltage and operating free-air temperature (unless otherwise noted) (see Note 4 and Figure 6)

PARAMETER		TEST CONDITIONS	MIN	TYP‡	MAX	UNIT	
I_I	Input leakage current	$\overline{\text{FORCEOFF}}$, FORCEON , $\overline{\text{EN}}$		± 0.01	± 1	μ A	
I_{CC}	Supply current ($T_A = 25^\circ\text{C}$)	Auto-powerdown disabled	No load, $\overline{\text{FORCEOFF}}$ and FORCEON at V_{CC}		0.3	1	mA
		Powered off	No load, $\overline{\text{FORCEOFF}}$ at GND		1	10	
		Auto-powerdown enabled	No load, $\overline{\text{FORCEOFF}}$ at V_{CC} , FORCEON at GND, All RIN are open or grounded		1	10	μ A

‡ All typical values are at $V_{CC} = 3.3$ V or $V_{CC} = 5$ V, and $T_A = 25^\circ\text{C}$.

NOTE 4: Test conditions are C1–C4 = 0.1 μ F at $V_{CC} = 3.3$ V \pm 0.3 V; C1 = 0.047 μ F, C2–C4 = 0.33 μ F at $V_{CC} = 5$ V \pm 0.5 V.



SN65C3221, SN75C3221

3-V TO 5.5-V SINGLE-CHANNEL RS-232 COMPATIBLE LINE DRIVER/RECEIVER

SLLS351E – APRIL 2002 – REVISED OCTOBER 2004

DRIVER SECTION

electrical characteristics over recommended ranges of supply voltage and operating free-air temperature (unless otherwise noted) (see Note 4 and Figure 6)

PARAMETER		TEST CONDITIONS	MIN	TYP†	MAX	UNIT
V _{OH}	High-level output voltage	DOUT at R _L = 3 kΩ to GND, DIN = GND	5	5.4		V
V _{OL}	Low-level output voltage	DOUT at R _L = 3 kΩ to GND, DIN = V _{CC}	-5	-5.4		V
I _{IH}	High-level input current	V _I = V _{CC}		±0.01	±1	μA
I _{IL}	Low-level input current	V _I at GND		±0.01	±1	μA
I _{OS}	Short-circuit output current‡	V _{CC} = 3.6 V, V _O = 0 V		±35	±60	mA
		V _{CC} = 5.5 V, V _O = 0 V		±35	±90	
r _o	Output resistance	V _{CC} , V ₊ , and V ₋ = 0 V, V _O = ±2 V	300	10M		Ω
I _{off}	Output leakage current	FORCEOFF = GND	V _O = ±12 V, V _{CC} = 3 V to 3.6 V		±25	μA
			V _O = ±10 V, V _{CC} = 4.5 V to 5.5 V		±25	

† All typical values are at V_{CC} = 3.3 V or V_{CC} = 5 V, and T_A = 25°C.

‡ Short-circuit durations should be controlled to prevent exceeding the device absolute power-dissipation ratings, and not more than one output should be shorted at a time.

NOTE 4: Test conditions are C1–C4 = 0.1 μF at V_{CC} = 3.3 V ± 0.3 V; C1 = 0.047 μF, C2–C4 = 0.33 μF at V_{CC} = 5 V ± 0.5 V.

switching characteristics over recommended ranges of supply voltage and operating free-air temperature (unless otherwise noted) (see Note 4 and Figure 6)

PARAMETER		TEST CONDITIONS	MIN	TYP†	MAX	UNIT
Maximum data rate (see Figure 1)	R _L = 3 kΩ	C _L = 1000 pF	250			kbit/s
		C _L = 250 pF, V _{CC} = 3 V to 4.5 V	1000			
		C _L = 1000 pF, V _{CC} = 4.5 V to 5.5 V	1000			
t _{sk(p)}	Pulse skew§	C _L = 150 pF to 2500 pF, R _L = 3 kΩ to 7 kΩ, See Figure 2	100			ns
SR(tr)	Slew rate, transition region (see Figure 1)	V _{CC} = 3.3 V, R _L = 3 kΩ to 7 kΩ, C _L = 150 pF to 1000 pF	18		150	V/μs

† All typical values are at V_{CC} = 3.3 V or V_{CC} = 5 V, and T_A = 25°C.

§ Pulse skew is defined as |t_{pLH} - t_{pHL}| of each channel of the same device.

NOTE 4: Test conditions are C1–C4 = 0.1 μF at V_{CC} = 3.3 V ± 0.3 V; C1 = 0.047 μF, C2–C4 = 0.33 μF at V_{CC} = 5 V ± 0.5 V.

ESD protection

TERMINAL		TEST CONDITIONS	TYP	UNIT
NAME	NO.			
DOUT	13	HBM	±15	kV



SN65C3221, SN75C3221

3-V TO 5.5-V SINGLE-CHANNEL RS-232 COMPATIBLE LINE DRIVER/RECEIVER

SLLS351E – APRIL 2002 – REVISED OCTOBER 2004

RECEIVER SECTION

electrical characteristics over recommended ranges of supply voltage and operating free-air temperature (unless otherwise noted) (see Note 4 and Figure 6)

PARAMETER		TEST CONDITIONS	MIN	TYP†	MAX	UNIT
V _{OH}	High-level output voltage	I _{OH} = -1 mA	V _{CC} - 0.6 V	V _{CC} - 0.1 V		V
V _{OL}	Low-level output voltage	I _{OL} = 1.6 mA			0.4	V
V _{IT+}	Positive-going input threshold voltage	V _{CC} = 3.3 V		1.6	2.4	V
		V _{CC} = 5 V		1.9	2.4	
V _{IT-}	Negative-going input threshold voltage	V _{CC} = 3.3 V	0.6	1.1		V
		V _{CC} = 5 V	0.8	1.4		
V _{hys}	Input hysteresis (V _{IT+} - V _{IT-})			0.5		V
I _{off}	Output leakage current	FORCEOFF = 0 V		±0.05	±10	μA
r _i	Input resistance	V _I = ±3 V to ±25 V	3	5	7	kΩ

† All typical values are at V_{CC} = 3.3 V or V_{CC} = 5 V, and T_A = 25°C.

NOTE 4: Test conditions are C1-C4 = 0.1 μF at V_{CC} = 3.3 V ± 0.3 V; C1 = 0.047 μF, C2-C4 = 0.33 μF at V_{CC} = 5 V ± 0.5 V.

switching characteristics over recommended ranges of supply voltage and operating free-air temperature (unless otherwise noted) (see Note 4)

PARAMETER		TEST CONDITIONS	MIN	TYP†	MAX	UNIT
t _{PLH}	Propagation delay time, low- to high-level output	C _L = 150 pF, See Figure 3		150		ns
t _{PHL}	Propagation delay time, high- to low-level output	C _L = 150 pF, See Figure 3		150		ns
t _{en}	Output enable time	C _L = 150 pF, R _L = 3 kΩ, See Figure 4		200		ns
t _{dis}	Output disable time	C _L = 150 pF, R _L = 3 kΩ, See Figure 4		200		ns
t _{sk(p)}	Pulse skew‡	See Figure 3		50		ns

† All typical values are at V_{CC} = 3.3 V or V_{CC} = 5 V, and T_A = 25°C.

‡ Pulse skew is defined as |t_{PLH} - t_{PHL}| of each channel of the same device.

NOTE 4: Test conditions are C1-C4 = 0.1 μF at V_{CC} = 3.3 V ± 0.3 V; C1 = 0.047 μF, C2-C4 = 0.33 μF at V_{CC} = 5 V ± 0.5 V.

ESD protection

TERMINAL		TEST CONDITIONS	TYP	UNIT
NAME	NO.			
RIN	8	HBM	±15	kV

SN65C3221, SN75C3221
3-V TO 5.5-V SINGLE-CHANNEL RS-232 COMPATIBLE LINE DRIVER/RECEIVER

SLLS351E – APRIL 2002 – REVISED OCTOBER 2004

AUTO-POWERDOWN SECTION

electrical characteristics over recommended ranges of supply voltage and operating free-air temperature (unless otherwise noted) (see Figure 5)

PARAMETER		TEST CONDITIONS	MIN	MAX	UNIT
$V_{T+}(\text{valid})$	Receiver input threshold for $\overline{\text{INVALID}}$ high-level output voltage	FORCEON = GND, $\overline{\text{FORCEOFF}} = V_{CC}$		2.7	V
$V_{T-}(\text{valid})$	Receiver input threshold for $\overline{\text{INVALID}}$ high-level output voltage	FORCEON = GND, $\overline{\text{FORCEOFF}} = V_{CC}$	-2.7		V
$V_{T}(\text{invalid})$	Receiver input threshold for $\overline{\text{INVALID}}$ low-level output voltage	FORCEON = GND, $\overline{\text{FORCEOFF}} = V_{CC}$	-0.3	0.3	V
V_{OH}	$\overline{\text{INVALID}}$ high-level output voltage	$I_{OH} = -1 \text{ mA}$, FORCEON = GND, $\overline{\text{FORCEOFF}} = V_{CC}$	$V_{CC}-0.6$		V
V_{OL}	$\overline{\text{INVALID}}$ low-level output voltage	$I_{OL} = 1.6 \text{ mA}$, FORCEON = GND, $\overline{\text{FORCEOFF}} = V_{CC}$		0.4	V

switching characteristics over recommended ranges of supply voltage and operating free-air temperature (unless otherwise noted) (see Figure 5)

PARAMETER		MIN	TYP†	MAX	UNIT
t_{valid}	Propagation delay time, low- to high-level output		1		μs
t_{invalid}	Propagation delay time, high- to low-level output		30		μs
t_{en}	Supply enable time		100		μs

† All typical values are at $V_{CC} = 3.3 \text{ V}$ or $V_{CC} = 5 \text{ V}$, and $T_A = 25^\circ\text{C}$.



SN65C3221, SN75C3221

3-V TO 5.5-V SINGLE-CHANNEL RS-232 COMPATIBLE LINE DRIVER/RECEIVER

SLLS351E – APRIL 2002 – REVISED OCTOBER 2004

PARAMETER MEASUREMENT INFORMATION

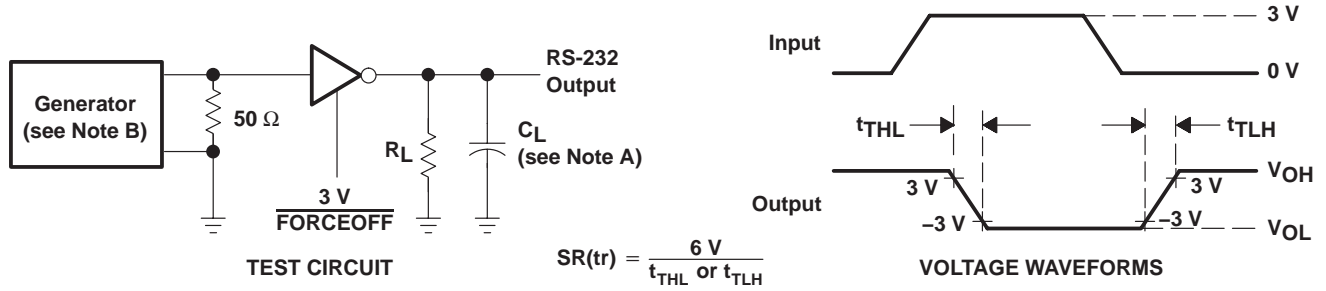

NOTES: A. C_L includes probe and jig capacitance.
 B. The pulse generator has the following characteristics: PRR = 250 kbit/s, $Z_O = 50\ \Omega$, 50% duty cycle, $t_r \leq 10\text{ ns}$, $t_f \leq 10\text{ ns}$.

Figure 1. Driver Slew Rate

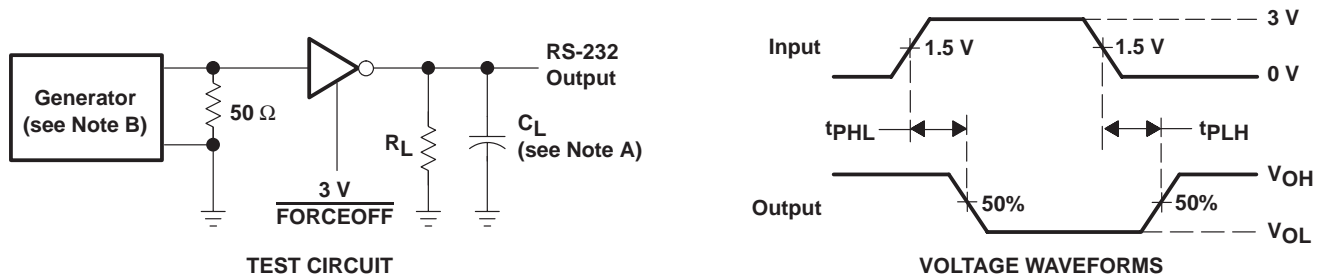

NOTES: A. C_L includes probe and jig capacitance.
 B. The pulse generator has the following characteristics: PRR = 250 kbit/s, $Z_O = 50\ \Omega$, 50% duty cycle, $t_r \leq 10\text{ ns}$, $t_f \leq 10\text{ ns}$.

Figure 2. Driver Pulse Skew

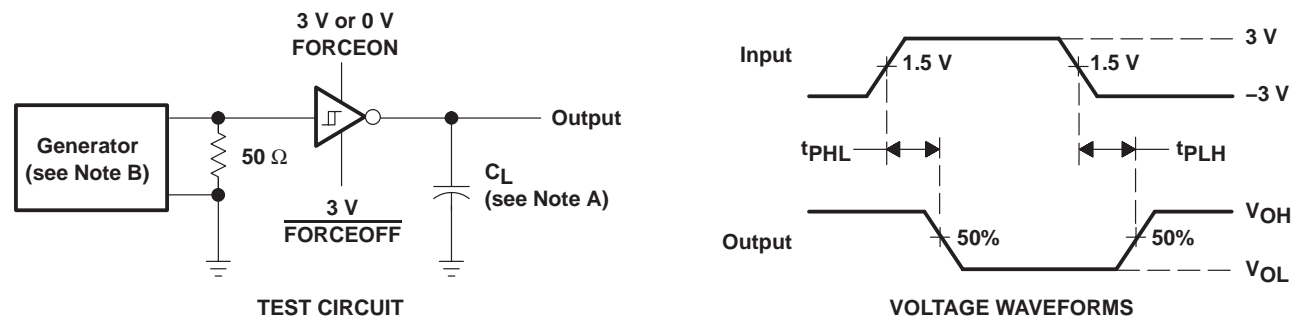

NOTES: A. C_L includes probe and jig capacitance.
 B. The pulse generator has the following characteristics: $Z_O = 50\ \Omega$, 50% duty cycle, $t_r \leq 10\text{ ns}$, $t_f \leq 10\text{ ns}$.

Figure 3. Receiver Propagation Delay Times

SN65C3221, SN75C3221 3-V TO 5.5-V SINGLE-CHANNEL RS-232 COMPATIBLE LINE DRIVER/RECEIVER

SLLS351E – APRIL 2002 – REVISED OCTOBER 2004

PARAMETER MEASUREMENT INFORMATION

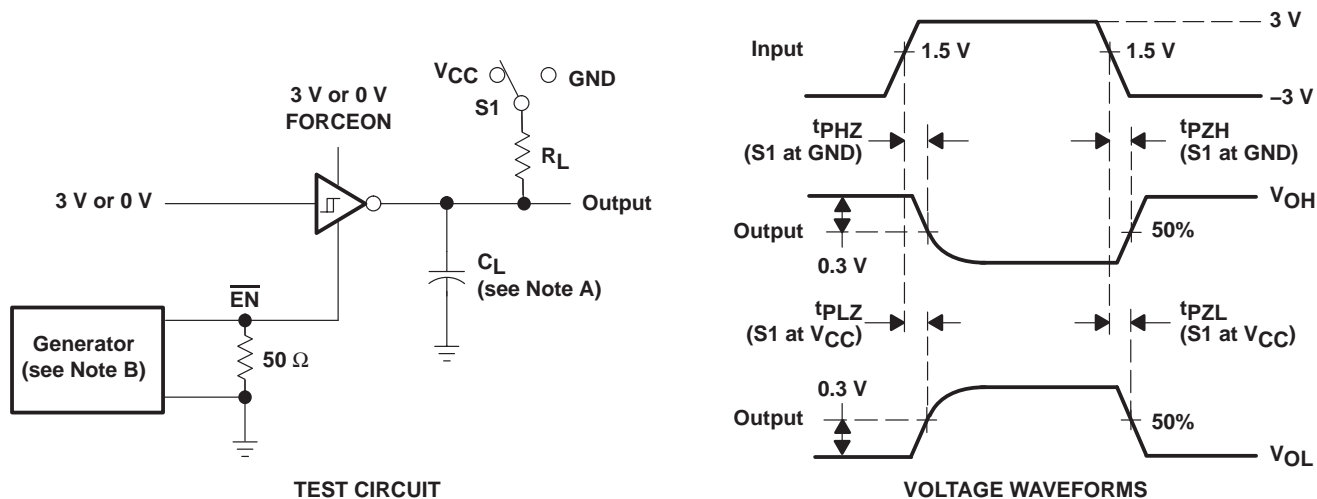

- NOTES:
- A. C_L includes probe and jig capacitance.
 - B. The pulse generator has the following characteristics: $Z_O = 50 \Omega$, 50% duty cycle, $t_r \leq 10 \text{ ns}$, $t_f \leq 10 \text{ ns}$.
 - C. t_{PLZ} and t_{PHZ} are the same as t_{dis} .
 - D. t_{PZL} and t_{PZH} are the same as t_{en} .

Figure 4. Receiver Enable and Disable Times

PARAMETER MEASUREMENT INFORMATION

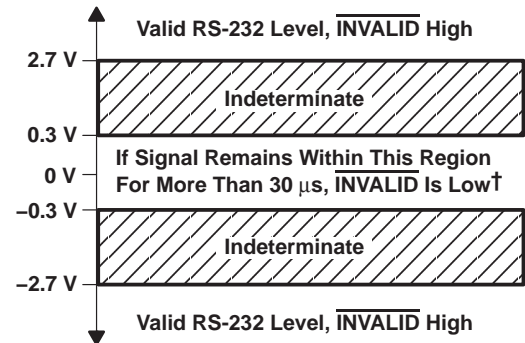
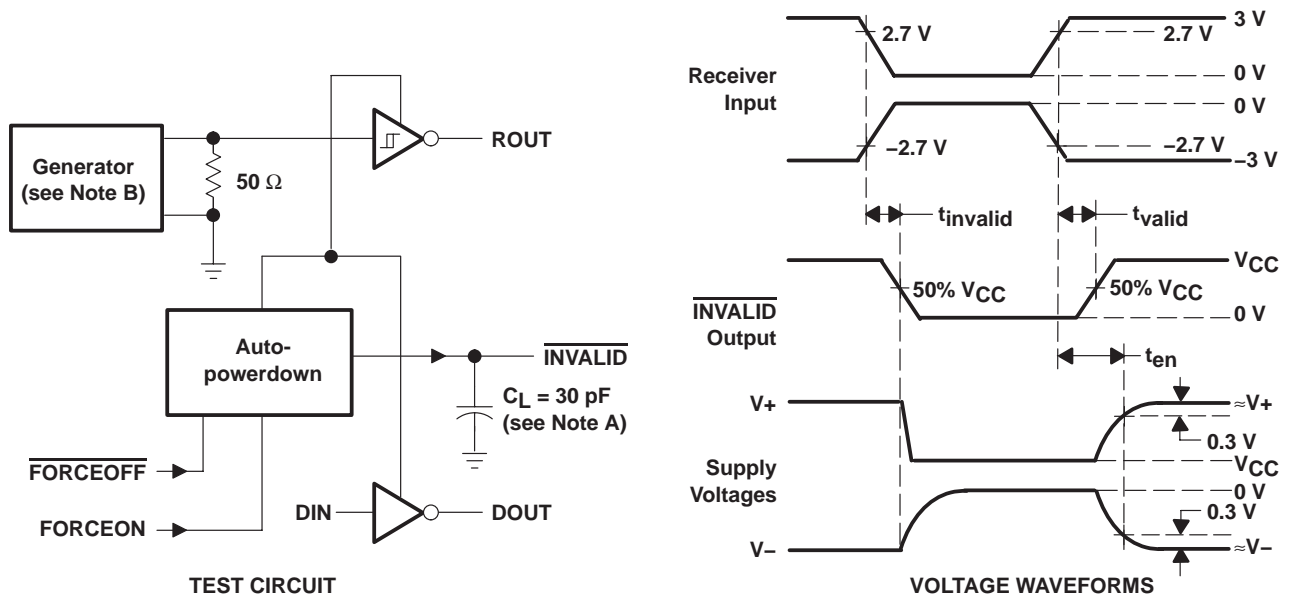

† Auto-powerdown disables drivers and reduces supply current to 1 μA.

- NOTES: A. C_L includes probe and jig capacitance.
 B. The pulse generator has the following characteristics: PRR = 5 kbit/s, $Z_O = 50 \Omega$, 50% duty cycle, $t_r \leq 10$ ns, $t_f \leq 10$ ns.

Figure 5. $\overline{\text{INVALID}}$ Propagation Delay Times and Driver Enabling Time

SN65C3221, SN75C3221 3-V TO 5.5-V SINGLE-CHANNEL RS-232 COMPATIBLE LINE DRIVER/RECEIVER

SLLS351E – APRIL 2002 – REVISED OCTOBER 2004

APPLICATION INFORMATION

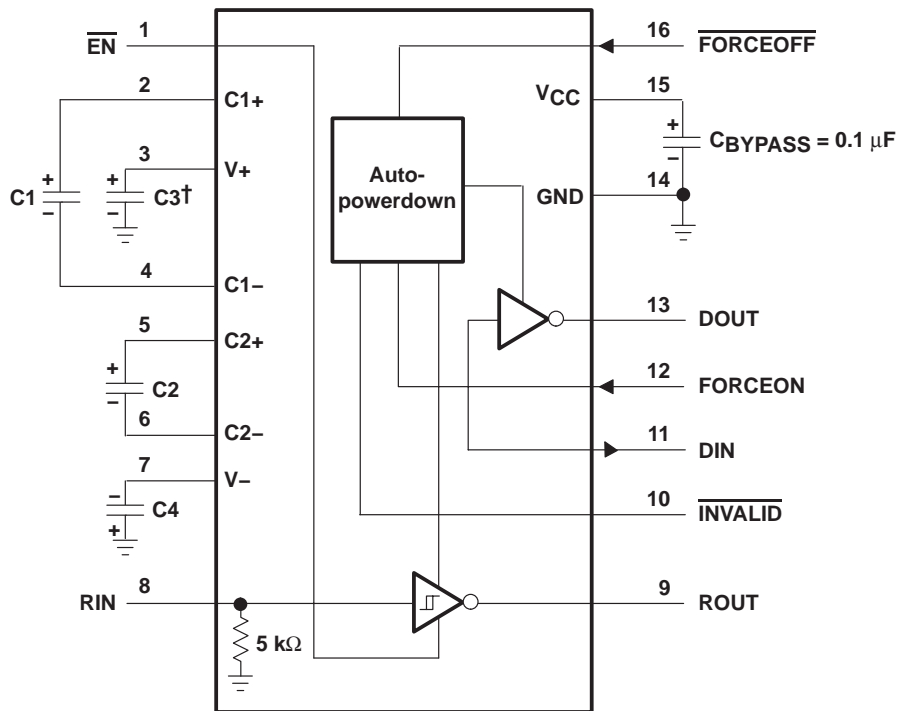

† C3 can be connected to V_{CC} or GND.
NOTE A: Resistor values shown are nominal.

V_{CC} vs CAPACITOR VALUES

V _{CC}	C1	C2, C3, and C4
3.3 V ± 0.3 V	0.1 μF	0.1 μF
5 V ± 0.5 V	0.047 μF	0.33 μF
3 V to 5.5 V	0.1 μF	0.47 μF

Figure 6. Typical Operating Circuit and Capacitor Values

PACKAGING INFORMATION

Orderable Device	Status (1)	Package Type	Package Drawing	Pins	Package Qty	Eco Plan (2)	Lead/Ball Finish (6)	MSL Peak Temp (3)	Op Temp (°C)	Device Marking (4/5)	Samples
SN65C3221DB	ACTIVE	SSOP	DB	16	80	Green (RoHS & no Sb/Br)	CU NIPDAU	Level-1-260C-UNLIM	-40 to 85	CB3221	Samples
SN65C3221DBR	ACTIVE	SSOP	DB	16	2000	Green (RoHS & no Sb/Br)	CU NIPDAU	Level-1-260C-UNLIM	-40 to 85	CB3221	Samples
SN65C3221DBRE4	ACTIVE	SSOP	DB	16	2000	Green (RoHS & no Sb/Br)	CU NIPDAU	Level-1-260C-UNLIM	-40 to 85	CB3221	Samples
SN65C3221PW	ACTIVE	TSSOP	PW	16	90	Green (RoHS & no Sb/Br)	CU NIPDAU	Level-1-260C-UNLIM	-40 to 85	CB3221	Samples
SN65C3221PWR	ACTIVE	TSSOP	PW	16	2000	Green (RoHS & no Sb/Br)	CU NIPDAU	Level-1-260C-UNLIM	-40 to 85	CB3221	Samples
SN65C3221PWRE4	ACTIVE	TSSOP	PW	16	2000	Green (RoHS & no Sb/Br)	CU NIPDAU	Level-1-260C-UNLIM	-40 to 85	CB3221	Samples
SN75C3221DBR	ACTIVE	SSOP	DB	16	2000	Green (RoHS & no Sb/Br)	CU NIPDAU	Level-1-260C-UNLIM	0 to 70	CA3221	Samples
SN75C3221DW	PREVIEW	SOIC	DW	16	40	TBD	Call TI	Call TI	0 to 70		
SN75C3221PW	ACTIVE	TSSOP	PW	16	90	Green (RoHS & no Sb/Br)	CU NIPDAU	Level-1-260C-UNLIM	0 to 70	CA3221	Samples
SN75C3221PWE4	ACTIVE	TSSOP	PW	16	90	Green (RoHS & no Sb/Br)	CU NIPDAU	Level-1-260C-UNLIM	0 to 70	CA3221	Samples
SN75C3221PWR	ACTIVE	TSSOP	PW	16	2000	Green (RoHS & no Sb/Br)	CU NIPDAU	Level-1-260C-UNLIM	0 to 70	CA3221	Samples
SN75C3221PWRG4	ACTIVE	TSSOP	PW	16	2000	Green (RoHS & no Sb/Br)	CU NIPDAU	Level-1-260C-UNLIM	0 to 70	CA3221	Samples

(1) The marketing status values are defined as follows:

ACTIVE: Product device recommended for new designs.

LIFEBUY: TI has announced that the device will be discontinued, and a lifetime-buy period is in effect.

NRND: Not recommended for new designs. Device is in production to support existing customers, but TI does not recommend using this part in a new design.

PREVIEW: Device has been announced but is not in production. Samples may or may not be available.

OBSOLETE: TI has discontinued the production of the device.

(2) **RoHS:** TI defines "RoHS" to mean semiconductor products that are compliant with the current EU RoHS requirements for all 10 RoHS substances, including the requirement that RoHS substance do not exceed 0.1% by weight in homogeneous materials. Where designed to be soldered at high temperatures, "RoHS" products are suitable for use in specified lead-free processes. TI may reference these types of products as "Pb-Free".

RoHS Exempt: TI defines "RoHS Exempt" to mean products that contain lead but are compliant with EU RoHS pursuant to a specific EU RoHS exemption.

Green: TI defines "Green" to mean the content of Chlorine (Cl) and Bromine (Br) based flame retardants meet JS709B low halogen requirements of ≤ 1000 ppm threshold. Antimony trioxide based flame retardants must also meet the ≤ 1000 ppm threshold requirement.

(3) MSL, Peak Temp. - The Moisture Sensitivity Level rating according to the JEDEC industry standard classifications, and peak solder temperature.

(4) There may be additional marking, which relates to the logo, the lot trace code information, or the environmental category on the device.

(5) Multiple Device Markings will be inside parentheses. Only one Device Marking contained in parentheses and separated by a "~" will appear on a device. If a line is indented then it is a continuation of the previous line and the two combined represent the entire Device Marking for that device.

(6) Lead/Ball Finish - Orderable Devices may have multiple material finish options. Finish options are separated by a vertical ruled line. Lead/Ball Finish values may wrap to two lines if the finish value exceeds the maximum column width.

Important Information and Disclaimer: The information provided on this page represents TI's knowledge and belief as of the date that it is provided. TI bases its knowledge and belief on information provided by third parties, and makes no representation or warranty as to the accuracy of such information. Efforts are underway to better integrate information from third parties. TI has taken and continues to take reasonable steps to provide representative and accurate information but may not have conducted destructive testing or chemical analysis on incoming materials and chemicals. TI and TI suppliers consider certain information to be proprietary, and thus CAS numbers and other limited information may not be available for release.

In no event shall TI's liability arising out of such information exceed the total purchase price of the TI part(s) at issue in this document sold by TI to Customer on an annual basis.

OTHER QUALIFIED VERSIONS OF SN65C3221 :

- Automotive: [SN65C3221-Q1](#)

NOTE: Qualified Version Definitions:

- Automotive - Q100 devices qualified for high-reliability automotive applications targeting zero defects

TAPE AND REEL INFORMATION

QUADRANT ASSIGNMENTS FOR PIN 1 ORIENTATION IN TAPE

*All dimensions are nominal

Device	Package Type	Package Drawing	Pins	SPQ	Reel Diameter (mm)	Reel Width W1 (mm)	A0 (mm)	B0 (mm)	K0 (mm)	P1 (mm)	W (mm)	Pin1 Quadrant
SN65C3221PWR	TSSOP	PW	16	2000	330.0	12.4	6.9	5.6	1.6	8.0	12.0	Q1
SN75C3221PWR	TSSOP	PW	16	2000	330.0	12.4	6.9	5.6	1.6	8.0	12.0	Q1

TAPE AND REEL BOX DIMENSIONS

*All dimensions are nominal

Device	Package Type	Package Drawing	Pins	SPQ	Length (mm)	Width (mm)	Height (mm)
SN65C3221PWR	TSSOP	PW	16	2000	367.0	367.0	35.0
SN75C3221PWR	TSSOP	PW	16	2000	367.0	367.0	35.0



4220204/A 02/2017

NOTES:

1. All linear dimensions are in millimeters. Any dimensions in parenthesis are for reference only. Dimensioning and tolerancing per ASME Y14.5M.
2. This drawing is subject to change without notice.
3. This dimension does not include mold flash, protrusions, or gate burrs. Mold flash, protrusions, or gate burrs shall not exceed 0.15 mm per side.
4. This dimension does not include interlead flash. Interlead flash shall not exceed 0.25 mm per side.
5. Reference JEDEC registration MO-153.

EXAMPLE BOARD LAYOUT

PW0016A

TSSOP - 1.2 mm max height

SMALL OUTLINE PACKAGE



LAND PATTERN EXAMPLE
EXPOSED METAL SHOWN
SCALE: 10X



SOLDER MASK DETAILS

4220204/A 02/2017

NOTES: (continued)

- 6. Publication IPC-7351 may have alternate designs.
- 7. Solder mask tolerances between and around signal pads can vary based on board fabrication site.

EXAMPLE STENCIL DESIGN

PW0016A

TSSOP - 1.2 mm max height

SMALL OUTLINE PACKAGE



SOLDER PASTE EXAMPLE
BASED ON 0.125 mm THICK STENCIL
SCALE: 10X

4220204/A 02/2017

NOTES: (continued)

8. Laser cutting apertures with trapezoidal walls and rounded corners may offer better paste release. IPC-7525 may have alternate design recommendations.
9. Board assembly site may have different recommendations for stencil design.

DB (R-PDSO-G**)

PLASTIC SMALL-OUTLINE

28 PINS SHOWN



- NOTES: A. All linear dimensions are in millimeters.
 B. This drawing is subject to change without notice.
 C. Body dimensions do not include mold flash or protrusion not to exceed 0,15.
 D. Falls within JEDEC MO-150

IMPORTANT NOTICE AND DISCLAIMER

TI PROVIDES TECHNICAL AND RELIABILITY DATA (INCLUDING DATASHEETS), DESIGN RESOURCES (INCLUDING REFERENCE DESIGNS), APPLICATION OR OTHER DESIGN ADVICE, WEB TOOLS, SAFETY INFORMATION, AND OTHER RESOURCES "AS IS" AND WITH ALL FAULTS, AND DISCLAIMS ALL WARRANTIES, EXPRESS AND IMPLIED, INCLUDING WITHOUT LIMITATION ANY IMPLIED WARRANTIES OF MERCHANTABILITY, FITNESS FOR A PARTICULAR PURPOSE OR NON-INFRINGEMENT OF THIRD PARTY INTELLECTUAL PROPERTY RIGHTS.

These resources are intended for skilled developers designing with TI products. You are solely responsible for (1) selecting the appropriate TI products for your application, (2) designing, validating and testing your application, and (3) ensuring your application meets applicable standards, and any other safety, security, or other requirements. These resources are subject to change without notice. TI grants you permission to use these resources only for development of an application that uses the TI products described in the resource. Other reproduction and display of these resources is prohibited. No license is granted to any other TI intellectual property right or to any third party intellectual property right. TI disclaims responsibility for, and you will fully indemnify TI and its representatives against, any claims, damages, costs, losses, and liabilities arising out of your use of these resources.

TI's products are provided subject to TI's Terms of Sale (www.ti.com/legal/termsofsale.html) or other applicable terms available either on ti.com or provided in conjunction with such TI products. TI's provision of these resources does not expand or otherwise alter TI's applicable warranties or warranty disclaimers for TI products.

Mailing Address: Texas Instruments, Post Office Box 655303, Dallas, Texas 75265
Copyright © 2019, Texas Instruments Incorporated

Looking for pricing, stock, or lifecycle information?

Click below to explore more details on WIN SOURCE:

 [View SN65C3221PWR on WIN SOURCE](#)

 [Texas Instruments](#) Information

Optimize Your Supply Chain with WIN SOURCE Solutions

-  Global Sourcing Solution
-  Obsolete Management
-  Cost Control Management
-  Shortage Management
-  Alternative Solution
-  Excess Inventory Management