



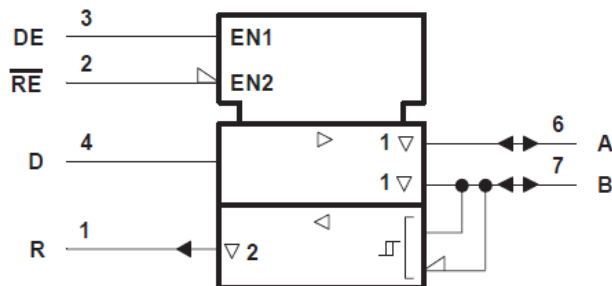
# SNx5ALS176, SN75ALS176A, and SN75ALS176B Differential Bus Transceivers

## 1 Features

- Meet or exceed the requirements of TIA/EIA-422-B, TIA/EIA-485-A<sup>1</sup> and ITU recommendations V.11 and X.27
- Operate at data rates up to 35 Mbaud
- Four skew limits available:
  - SN65ALS176: 15 ns
  - SN75ALS176: 10 ns
  - SN75ALS176A: 7.5 ns
  - SN75ALS176B: 5 ns
- Designed for multipoint transmission on long bus lines in noisy environments
- Low supply-current requirements: 30 mA max
- Wide positive and negative input/output bus-voltage ranges
- Thermal shutdown protection
- Driver positive and negative current limiting
- Receiver input hysteresis
- Glitch-free power-up and power-down protection
- Receiver open-circuit fail-safe design

## 2 Description

The SN65ALS176 and SN75ALS176 series differential bus transceivers are designed for bidirectional data communication on multipoint bus transmission lines. The devices are designed for balanced transmission lines and meet TIA/EIA-422-B, TIA/EIA-485-A, and ITU Recommendations V.11 and X.27.



A. This symbol is in accordance with ANSI/IEEE Std 91-1984 and IEC Publication 617-12.

**Logic Symbol**

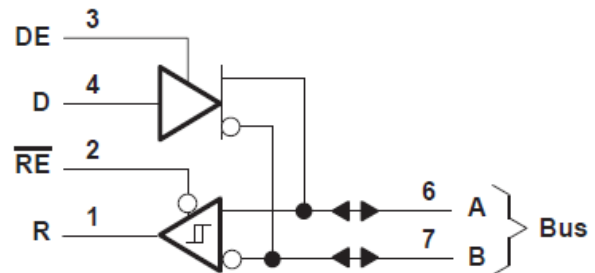
The SN65ALS176 and SN75ALS176 series combine a 3-state, differential line driver and a differential input line receiver, both of which operate from a single 5-V power supply. The driver and receiver have active-high and active-low enables, respectively, that can be connected together externally to function as a direction control. The driver differential outputs and the receiver differential inputs are connected internally to form a differential input/output (I/O) bus port that is designed to offer minimum loading to the bus when the driver is disabled or  $V_{CC} = 0$ . This port features wide positive and negative common-mode voltage ranges, making the device suitable for party-line applications.

The SN65ALS176 is characterized for operation from  $-40^{\circ}\text{C}$  to  $85^{\circ}\text{C}$ . The SN75ALS176 series is characterized for operation from  $0^{\circ}\text{C}$  to  $70^{\circ}\text{C}$ .

### Package Information

PART NUMBER	PACKAGE <sup>(1)</sup>	BODY SIZE (NOM)
SNx5ALS176	D (SOIC)	4.9 mm x 3.91 mm
	P (PDIP)	9.81 mm x 6.35 mm
SN75ALS176A	D (SOIC)	4.9 mm x 3.91 mm
	P (PDIP)	9.81 mm x 6.35 mm
SN75ALS176B	D (SOIC)	4.9 mm x 3.91 mm
	P (PDIP)	9.81 mm x 6.35 mm

(1) For all available packages, see the orderable addendum at the end of the data sheet.



**Logic Diagram (Positive Logic)**

<sup>1</sup> These devices meet or exceed the requirements of TIA/EIA-485-A, except for the Generator Contention Test (para. 3.4.2) and the Generator Current Limit (para. 3.4.3). The applied test voltage ranges are  $-6\text{ V}$  to  $8\text{ V}$  for the SN75ALS176, SN75ALS176A, and SN75ALS176B and  $-4\text{ V}$  to  $8\text{ V}$  for the SN65ALS180.



## Table of Contents

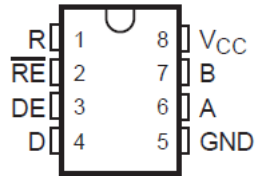
<b>1 Features</b> .....	<b>1</b>	<b>6 Parameter Measurement Information</b> .....	<b>11</b>
<b>2 Description</b> .....	<b>1</b>	<b>7 Detailed Description</b> .....	<b>14</b>
<b>3 Revision History</b> .....	<b>2</b>	7.1 Functional Block Diagram.....	14
<b>4 Pin Configuration and Functions</b> .....	<b>3</b>	7.2 Device Functional Modes.....	14
<b>5 Specifications</b> .....	<b>4</b>	<b>8 Application and Implementation</b> .....	<b>15</b>
5.1 Absolute Maximum Ratings .....	4	8.1 Application Information.....	15
5.2 Recommended Operating Conditions.....	4	8.2 Typical Application.....	15
5.3 Thermal Information.....	4	<b>9 Device and Documentation Support</b> .....	<b>16</b>
5.4 Electrical Characteristics - Driver.....	5	9.1 Documentation Support.....	16
5.5 Switching Characteristics - Driver.....	5	9.2 Receiving Notification of Documentation Updates....	16
5.6 Switching Characteristics - Driver.....	6	9.3 Support Resources.....	16
5.7 Symbol Equivalents.....	6	9.4 Trademarks.....	16
5.8 Electrical Characteristics - Receiver.....	7	9.5 Electrostatic Discharge Caution.....	16
5.9 Switching Characteristics - Receiver.....	7	9.6 Glossary.....	16
5.10 Switching Characteristics - Receiver.....	8	<b>10 Mechanical, Packaging, and Orderable</b>	
5.11 Typical Characteristics.....	9	<b>Information</b> .....	<b>16</b>

### 3 Revision History

NOTE: Page numbers for previous revisions may differ from page numbers in the current version.

<b>Changes from Revision H (June 2000) to Revision I (January 2023)</b>	<b>Page</b>
• Changed the document to the latest TI format.....	1
• Deleted the Package thermal impedance from the <i>Absolute Maximum Ratings</i> .....	4
• Added the <i>Thermal Information</i> table.....	4
• Changed the <i>Typical Characteristics</i> graphs.....	9

## 4 Pin Configuration and Functions



**Figure 4-1. D or P Package (Top View)**

**Table 4-1. Pin Functions**

NO	Name	Type	Description
1	R	O	Receive data output
2	$\overline{RE}$	I	Receiver enable, active low
3	DE	i	Driver enable, active high
4	D	I	Driver data input
5	GND	GND	Local device ground
6	A	I/O	Driver output or receiver input (complementary to B)
7	B	I/O	Driver output or receiver input (complementary to A)
8	V <sub>CC</sub>	SUPPLY	4.75-V to 5.25-V supply

## 5 Specifications

### 5.1 Absolute Maximum Ratings

over operating free-air temperature range (unless otherwise noted)<sup>(1)</sup>

		MIN	MAX	UNIT
V <sub>CC</sub>	Supply voltage <sup>(2)</sup>		7	V
	Voltage range at any bus terminal	-7	12	V
V <sub>I</sub>	Enable input voltage		5.5	V
	Lead temperature 1,6 mm (1/16 inch) from case for 10 seconds		260	°C
T <sub>stg</sub>	Storage temperature range	-65	150	°C

- (1) Stresses beyond those listed under “absolute maximum ratings” may cause permanent damage to the device. These are stress ratings only, and functional operation of the device at these or any other conditions beyond those indicated under “recommended operating conditions” is not implied. Exposure to absolute-maximum-rated conditions for extended periods may affect device reliability.
- (2) All voltage values, except differential I/O bus voltage, are with respect to network ground terminal.

### 5.2 Recommended Operating Conditions

(unless otherwise noted)

		MIN	NOM	MAX	UNIT
V <sub>CC</sub>	Supply voltage	4.75	5	5.25	V
V <sub>I</sub> or V <sub>IC</sub>	Input voltage at any bus terminal (separately or common mode)			12	V
				-7	
V <sub>IH</sub>	High-level input voltage	D, DE, and $\overline{RE}$	2		V
V <sub>IL</sub>	Low-level input voltage	D, DE, and $\overline{RE}$		0.8	V
V <sub>ID</sub>	Differential input voltage <sup>(1)</sup>			±12	V
I <sub>OH</sub>	High-level output current	Driver		-60	mA
		Receiver		-400	µA
I <sub>OL</sub>	Low-level output current	Driver		60	mA
		Receiver		8	
T <sub>A</sub>	Operating free-air temperature	SN65ALS176	-40	85	°C
		SN75ALS176 series	0	70	

- (1) Differential input/output bus voltage is measured at the noninverting terminal A with respect to the inverting terminal B.

### 5.3 Thermal Information

THERMAL METRIC <sup>(1)</sup>		P (PDIP)	D (SOIC) SN65 Devices	D (SOIC) SN75 Devices	UNIT
		8-Pins	8-Pins	8-Pin	
R <sub>θJA</sub>	Junction-to-ambient thermal resistance	65.7	116.7	110	°C/W
R <sub>θJC(top)</sub>	Junction-to-case thermal resistance	54.7	56.3	44.1	°C/W
R <sub>θJB</sub>	Junction-to-board thermal resistance	42.1	63.4	53.5	°C/W
Ψ <sub>JT</sub>	Junction-to-top characterization parameter	23	8.8	4.8	°C/W
Ψ <sub>JB</sub>	Junction-to-board characterization parameter	41.7	62.6	52.7	°C/W
R <sub>θJC(bot)</sub>	Junction-to-case (bottom) thermal resistance	N/A	N/A	N/A	°C/W

- (1) For more information about traditional and new thermal metrics, see the [Semiconductor and IC package thermal metrics](#) application report.

## 5.4 Electrical Characteristics - Driver

over recommended ranges of supply voltage and operating free-air temperature range (unless otherwise noted)

PARAMETER		TEST CONDITIONS <sup>(1)</sup>		MIN	TYP <sup>(2)</sup>	MAX	UNIT
V <sub>IK</sub>	Input clamp voltage	I <sub>I</sub> = -18 mA				-1.5	V
V <sub>O</sub>	Output voltage	I <sub>O</sub> = 0		0		6	V
V <sub>OD1</sub>	Differential output voltage	I <sub>O</sub> = 0		1.5		6	V
V <sub>OD2</sub>	Differential output voltage	R <sub>L</sub> = 100 Ω	See Figure 6-1	½ V <sub>OD1</sub> or 2 <sup>(3)</sup>			V
		R <sub>L</sub> = 54 Ω	See Figure 6-1	1.5	2.5	5	V
V <sub>OD3</sub>	Differential output voltage	V <sub>test</sub> = -7 V to 12 V,	See Figure 6-2	1.5		5	V
Δ V <sub>OD</sub>	Change in magnitude of differential output voltage <sup>(4)</sup>	R <sub>L</sub> = 54 Ω or 100 Ω	See Figure 6-1			±0.2	V
V <sub>Oc</sub>	Common-mode output voltage	R <sub>L</sub> = 54 Ω or 100 Ω	See Figure 6-1			3 -1	V
Δ V <sub>Oc</sub>	Change in magnitude of common-mode output voltage <sup>(4)</sup>	R <sub>L</sub> = 54 Ω or 100 Ω	See Figure 6-1			±0.2	V
I <sub>O</sub>	Output current	Outputs disabled <sup>(6)</sup>		V <sub>O</sub> = 12 V		1	mA
				V <sub>O</sub> = -7 V		-0.8	
I <sub>IH</sub>	High-level input current	V <sub>I</sub> = 2.4 V				20	μA
I <sub>IL</sub>	Low-level input current	V <sub>I</sub> = 0.4 V				-400	μA
I <sub>OS</sub>	Short-circuit output current <sup>(5)</sup>	V <sub>O</sub> = -4 V	SN65ALS176			-250	mA
		V <sub>O</sub> = -6 V	SN75ALS176			-250	
		V <sub>O</sub> = 0				-150	
		V <sub>O</sub> = V <sub>CC</sub>				250	
		V <sub>O</sub> = 8 V				250	
I <sub>CC</sub>	Supply current	No load	Outputs enabled		23	30	mA
			Outputs disabled		19	26	

- (1) The power-off measurement in TIA/EIA-422-B applies to disabled outputs only and is not applied to combined inputs and outputs.
- (2) All typical values are at V<sub>CC</sub> = 5 V and T<sub>A</sub> = 25°C.
- (3) The minimum V<sub>OD2</sub> with a 100-Ω load is either 1/2 V<sub>OD1</sub> or 2 V, whichever is greater.
- (4) Δ|V<sub>OD</sub>| and Δ|V<sub>Oc</sub>| are the changes in magnitude of VOD and VOC, respectively, that occur when the input is changed from one logic state to the other.
- (5) Duration of the short circuit should not exceed one second for this test.
- (6) This applies for power on and power off. Refer to TIA/EIA-485-A for exact conditions. The TIA/EIA-422-B limit does not apply for a combined driver and receiver terminal.

## 5.5 Switching Characteristics - Driver

### SN65ALS176

over recommended ranges of supply voltage and operating free-air temperature range (unless otherwise noted)

PARAMETER		TEST CONDITIONS			MIN	TYP <sup>(1)</sup>	MAX	UNIT
t <sub>d(OD)</sub>	Differential output delay time	R <sub>L</sub> = 54 Ω	C <sub>L</sub> = 50 pF,	See Figure 6-3			15	ns
t <sub>sk(p)</sub>	Pulse skew <sup>(2)</sup>	R <sub>L</sub> = 54 Ω	C <sub>L</sub> = 50 pF,	See Figure 6-3		0	2	ns
t <sub>sk(lim)</sub>	Pulse skew <sup>(3)</sup>	R <sub>L</sub> = 54 Ω	C <sub>L</sub> = 50 pF,	See Figure 6-3			15	ns
t <sub>t(OD)</sub>	Differential output transition time	R <sub>L</sub> = 54 Ω	C <sub>L</sub> = 50 pF,	See Figure 6-3		8		ns
t <sub>PZH</sub>	Output enable time to high level	R <sub>L</sub> = 110 Ω	C <sub>L</sub> = 50 pF,	See Figure 6-4			80	ns
t <sub>PZL</sub>	Output enable time to low level	R <sub>L</sub> = 110 Ω	C <sub>L</sub> = 50 pF,	See Figure 6-5			30	ns
t <sub>PHZ</sub>	Output disable time from high level	R <sub>L</sub> = 110 Ω	C <sub>L</sub> = 50 pF,	See Figure 6-4			50	ns
t <sub>PLZ</sub>	Output disable time from low level	R <sub>L</sub> = 110 Ω	C <sub>L</sub> = 50 pF,	See Figure 6-5			30	ns

- (1) All typical values are at V<sub>CC</sub> = 5 V, T<sub>A</sub> = 25°C.

- (2) Pulse skew is defined as the  $|t_{PLH} - t_{PHL}|$  of each channel of the same device.
- (3) Skew limit is the maximum difference in propagation delay times between any two channels of any two devices.

## 5.6 Switching Characteristics - Driver

### SN75ALS176, SN75ALS176A, SN75ALS176B

over recommended ranges of supply voltage and operating free-air temperature range (unless otherwise noted)

PARAMETER		TEST CONDITIONS			MIN	TYP <sup>(1)</sup>	MAX	UNIT	
$t_{d(OD)}$	Differential output delay time	'ALS176	$R_L = 54 \Omega$	$C_L = 50 \text{ pF}$	See <a href="#">Figure 6-3</a>	3	8	13	ns
		'ALS176A				4	7	11.5	
		'ALS176B				5	8	10	
$t_{sk(p)}$	Pulse skew <sup>(2)</sup>		$R_L = 54 \Omega$	$C_L = 50 \text{ pF}$	See <a href="#">Figure 6-3</a>	0	2	ns	
$t_{sk(lim)}$	Pulse skew <sup>(3)</sup>	'ALS176	$R_L = 54 \Omega$	$C_L = 50 \text{ pF}$	See <a href="#">Figure 6-3</a>			10	ns
		'ALS176A						7.5	
		'ALS176B						5	
$t_{i(OD)}$	Differential output transition time		$R_L = 54 \Omega$	$C_L = 50 \text{ pF}$	See <a href="#">Figure 6-3</a>	8		ns	
$t_{PZH}$	Output enable time to high level		$R_L = 110 \Omega$	$C_L = 50 \text{ pF}$	See <a href="#">Figure 6-4</a>	23	50	ns	
$t_{PZL}$	Output enable time to low level		$R_L = 110 \Omega$	$C_L = 50 \text{ pF}$	See <a href="#">Figure 6-5</a>	14	20	ns	
$t_{PHZ}$	Output disable time from high level		$R_L = 110 \Omega$	$C_L = 50 \text{ pF}$	See <a href="#">Figure 6-4</a>	20	35	ns	
$t_{PLZ}$	Output disable time from low level		$R_L = 110 \Omega$	$C_L = 50 \text{ pF}$	See <a href="#">Figure 6-5</a>	8	17	ns	

- (1) All typical values are at  $V_{CC} = 5 \text{ V}$ ,  $T_A = 25^\circ\text{C}$ .
- (2) Pulse skew is defined as the  $|t_{PLH} - t_{PHL}|$  of each channel of the same device.
- (3) Skew limit is the maximum difference in propagation delay times between any two channels of any two devices.

## 5.7 Symbol Equivalents

DATA-SHEET PARAMETER	TIA/EIA-422-B	TIA/EIA-485-A
$V_O$	$V_{oa}, V_{ob}$	$V_{oa}, V_{ob}$
$ V_{OD1} $	$V_o$	$V_o$
$ V_{OD2} $	$V_t(R_L = 100 \Omega)$	$V_t(R_L = 54 \Omega)$
$ V_{OD3} $	None	$V_t$ (test termination measurement 2)
$\Delta V_{OD} $	$  V_t  -  V_t  $	$  V_t  -  V_t  $
$V_{OC}$	$ V_{os} $	$ V_{os} $
$\Delta V_{OC} $	$ V_{os} - V_{os} $	$ V_{os} - V_{os} $
$I_{OS}$	$ I_{sa} ,  I_{sb} $	None
$I_O$	$ I_{xa} ,  I_{xb} $	$I_{ia}, I_{ib}$

## 5.8 Electrical Characteristics - Receiver

over recommended ranges of common-mode input voltage, supply voltage, and operating free-air temperature range (unless otherwise noted)

PARAMETER		TEST CONDITIONS		MIN	TYP <sup>(1)</sup>	MAX	UNIT
V <sub>IT+</sub>	Positive-going input threshold voltage	V <sub>O</sub> = 2.7 V,	I <sub>O</sub> = -0.4 mA			0.2	V
V <sub>IT-</sub>	Negative-going input threshold voltage	V <sub>O</sub> = 0.5 V,	I <sub>O</sub> = 8 mA	-0.2 <sup>(2)</sup>			V
V <sub>hys</sub>	Hysteresis voltage (V <sub>IT+</sub> - V <sub>IT-</sub> )				60		mV
V <sub>IK</sub>	Enable-input clamp voltage	I <sub>I</sub> = -18 mA				-1.5	V
V <sub>OH</sub>	High-level output voltage	V <sub>ID</sub> = 200 mV, See Figure 6-6	I <sub>OH</sub> = -400 mA,	2.7			V
V <sub>OL</sub>	Low-level output voltage	V <sub>ID</sub> = -200 mV, See Figure 6	I <sub>OL</sub> = 8 mA,			0.45	V
I <sub>OZ</sub>	High-impedance-state output current	V <sub>O</sub> = 0.4 V to 2.4 V				±20	µA
V <sub>I</sub>	Line input current	Other input = 0 V <sup>(3)</sup>	V <sub>I</sub> = 12 V			1	mA
			V <sub>I</sub> = -7 V			-0.8	
I <sub>IH</sub>	High-level-enable input current	V <sub>IH</sub> = 2.7 V				20	µA
I <sub>IL</sub>	Low-level-enable input current	V <sub>IL</sub> = 0.4 V				-100	µA
r <sub>I</sub>	Input resistance			12	20		kΩ
I <sub>OS</sub>	Short-circuit output current	V <sub>ID</sub> = 200 mV,	V <sub>O</sub> = 0	-15		-85	mA
I <sub>CC</sub>	Supply current	No load	Outputs enabled		23	30	mA
			Outputs disabled		19	26	

(1) All typical values are at V<sub>CC</sub> = 5 V, T<sub>A</sub> = 25°C.

(2) The algebraic convention, in which the less positive (more negative) limit is designated minimum, is used in this data sheet for common-mode input voltage and threshold voltage levels only.

(3) This applies for power on and power off. Refer to TIA/EIA-485-A for exact conditions.

## 5.9 Switching Characteristics - Receiver

### SN65ALS176

over recommended ranges of supply voltage and operating free-air temperature range (unless otherwise noted)

PARAMETER		TEST CONDITIONS		MIN	TYP <sup>(1)</sup>	MAX	UNIT
t <sub>pd</sub>	Propagation time	V <sub>ID</sub> = -1.5 V to 1.5 V, See Figure 6-7	C <sub>L</sub> = 15 pF,			25	ns
t <sub>sk(p)</sub>	Pulse skew <sup>(2)</sup>	V <sub>ID</sub> = -1.5 V to 1.5 V, See Figure 6-7	C <sub>L</sub> = 15 pF,		0	2	ns
t <sub>sk(lim)</sub>	Pulse skew <sup>(3)</sup>	R <sub>L</sub> = 54 Ω See Figure 6-3	C <sub>L</sub> = 50 pF,			15	ns
t <sub>PZH</sub>	Output enable time to high level	C <sub>L</sub> = 15 pF,	See Figure 6-8		11	18	ns
t <sub>PZL</sub>	Output enable time to low level	C <sub>L</sub> = 15 pF,	See Figure 6-8		11	18	ns
t <sub>PHZ</sub>	Output disable time from high level	C <sub>L</sub> = 15 pF,	See Figure 6-8			50	ns
t <sub>PLZ</sub>	Output disable time from low level	C <sub>L</sub> = 15 pF,	See Figure 6-8			30	ns

(1) All typical values are at V<sub>CC</sub> = 5 V, T<sub>A</sub> = 25°C.

(2) Pulse skew is defined as the |t<sub>PLH</sub> - t<sub>PHL</sub>| of each channel of the same device.

(3) Skew limit is the maximum difference in propagation delay times between any two channels of any two devices.

## 5.10 Switching Characteristics - Receiver

### SN75ALS176, SN75ALS176A, SN75ALS176B

over recommended ranges of supply voltage and operating free-air temperature range (unless otherwise noted)

PARAMETER		TEST CONDITIONS		MIN	TYP <sup>(1)</sup>	MAX	UNIT	
t <sub>pd</sub>	Propagation time	'ALS176	V <sub>ID</sub> = -1.5 V to 1.5 V, See <a href="#">Figure 6-7</a>	C <sub>L</sub> = 15 pF,	9	14	19	ns
		'ALS176A			10.5	14	18	
		'ALS176B			11.5	13	16.5	
t <sub>sk(p)</sub>	Pulse skew <sup>(2)</sup>		V <sub>ID</sub> = -1.5 V to 1.5 V, See <a href="#">Figure 6-7</a>	C <sub>L</sub> = 15 pF,		0	2	ns
t <sub>sk(lim)</sub>	Pulse skew <sup>(3)</sup>	'ALS176	R <sub>L</sub> = 54 Ω See <a href="#">Figure 6-3</a>	C <sub>L</sub> = 50 pF,			10	ns
		'ALS176A					7.5	
		'ALS176B					5	
t <sub>PZH</sub>	Output enable time to high level		C <sub>L</sub> = 15 pF,	See <a href="#">Figure 6-8</a>		7	14	ns
t <sub>PZL</sub>	Output enable time to low level		C <sub>L</sub> = 15 pF,	See <a href="#">Figure 6-8</a>		20	35	ns
t <sub>PHZ</sub>	Output disable time from high level		C <sub>L</sub> = 15 pF,	See <a href="#">Figure 6-8</a>		20	35	ns
t <sub>PLZ</sub>	Output disable time from low level		C <sub>L</sub> = 15 pF,	See <a href="#">Figure 6-8</a>		8	17	ns

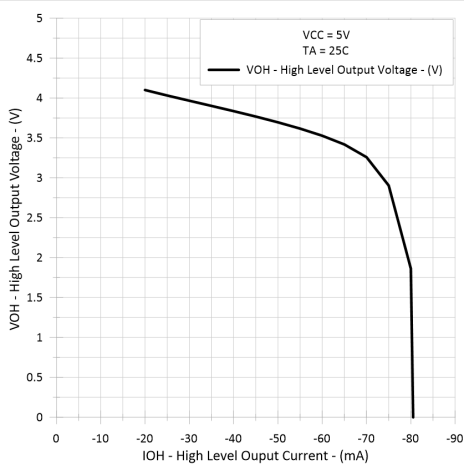
(1) All typical values are at V<sub>CC</sub> = 5 V, T<sub>A</sub> = 25°C.

(2) Pulse skew is defined as the |t<sub>PLH</sub> - t<sub>PHL</sub>| of each channel of the same device.

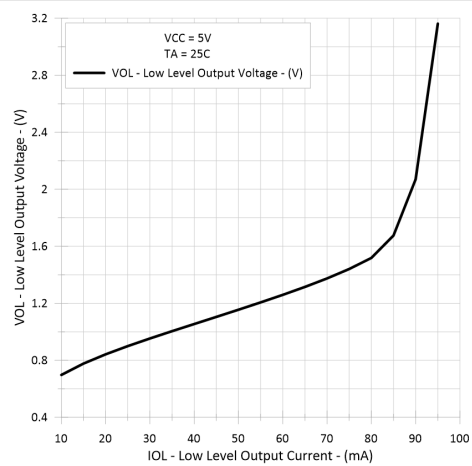
(3) Skew limit is the maximum difference in propagation delay times between any two channels of any two devices.

### 5.11 Typical Characteristics

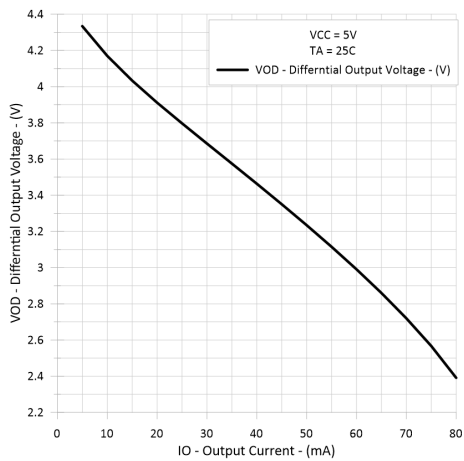
Operation of the device at these or any other conditions beyond those indicated under “recommended operating conditions” is not implied.



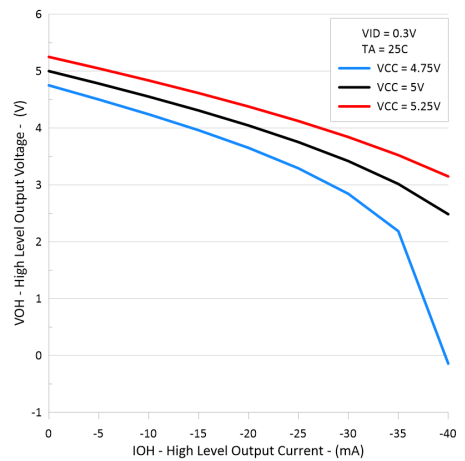
**Figure 5-1. Driver High-Level Output Voltage vs High-Level Output Current**



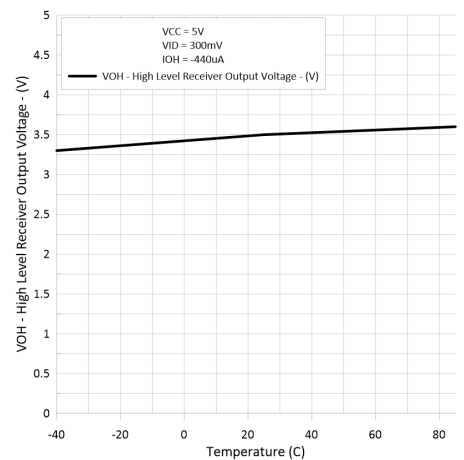
**Figure 5-2. Driver Low-Level Output Voltage vs Low-Level Output Current**



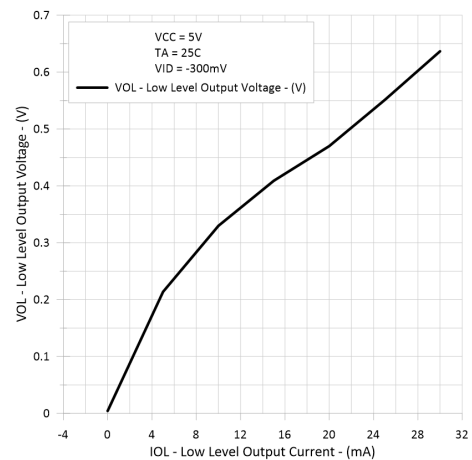
**Figure 5-3. Driver Differential Output Voltage vs Output Current**



**Figure 5-4. Receiver High-Level Output Voltage vs High-Level Output Current**



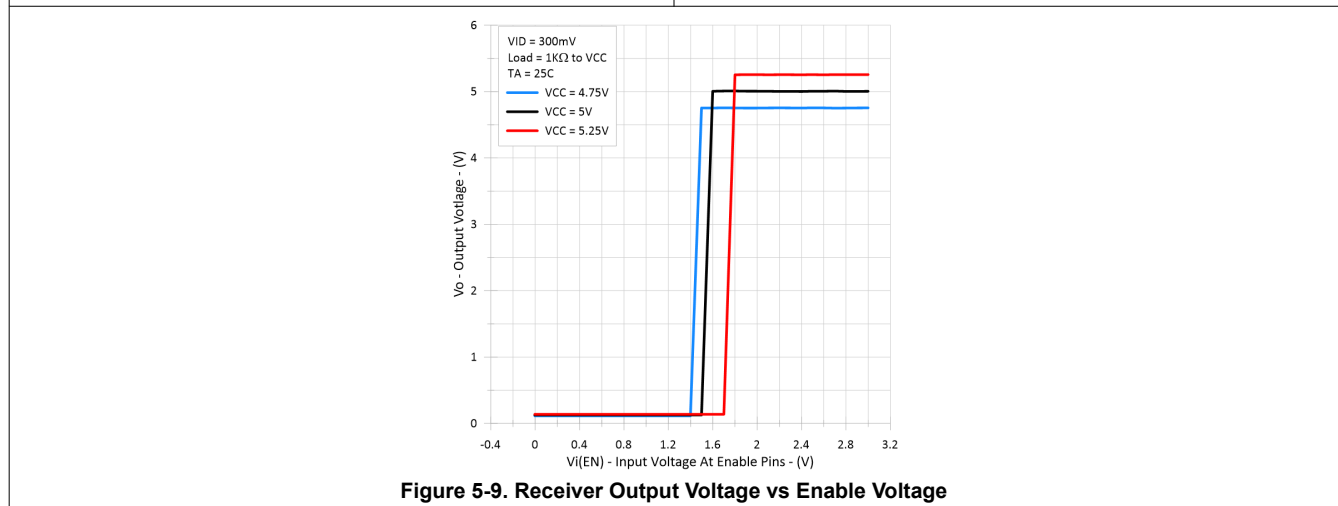
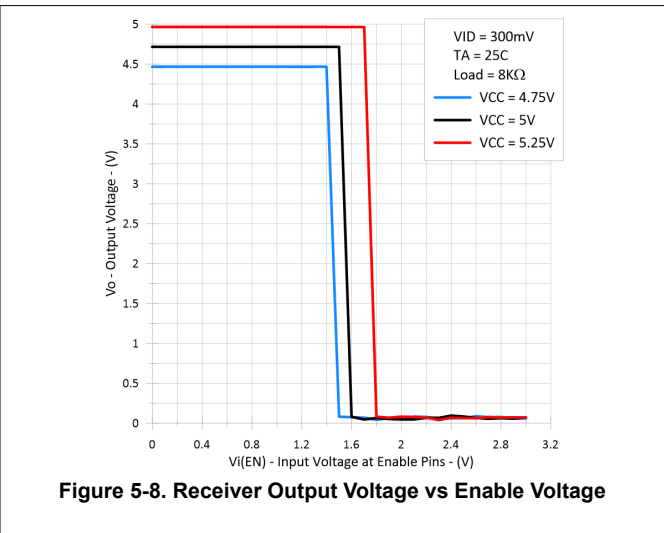
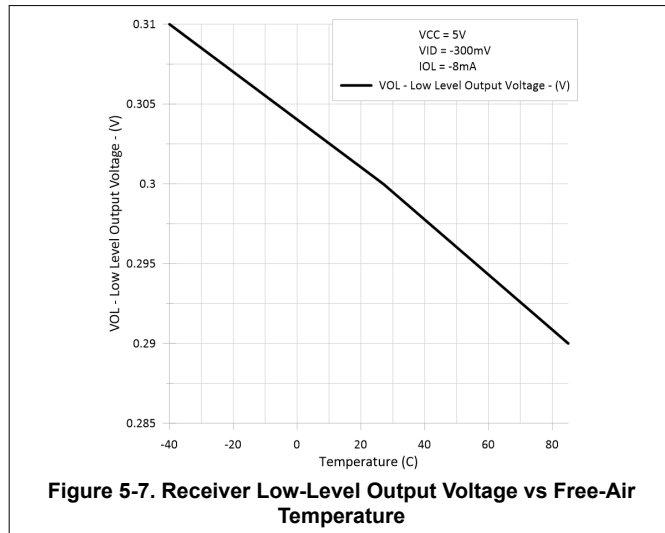
**Figure 5-5. Receiver High-Level Output Voltage vs Free-Air Temperature**



**Figure 5-6. Receiver Low-Level Output Voltage vs Low-Level Output Current**

### 5.11 Typical Characteristics (continued)

Operation of the device at these or any other conditions beyond those indicated under “recommended operating conditions” is not implied.



## 6 Parameter Measurement Information

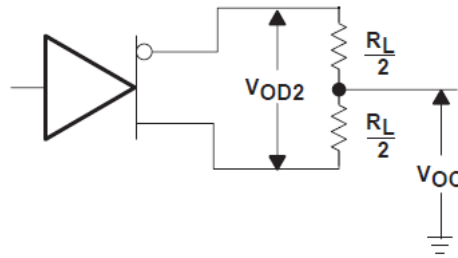


Figure 6-1. Driver  $V_{OD2}$  and  $V_{OC}$

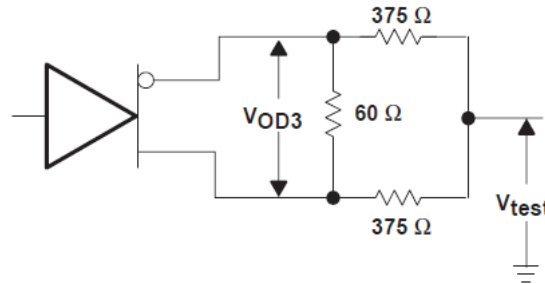
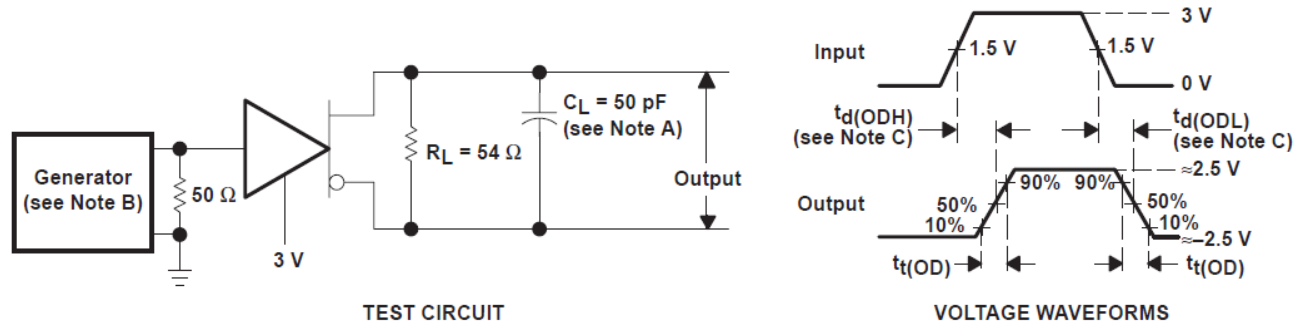
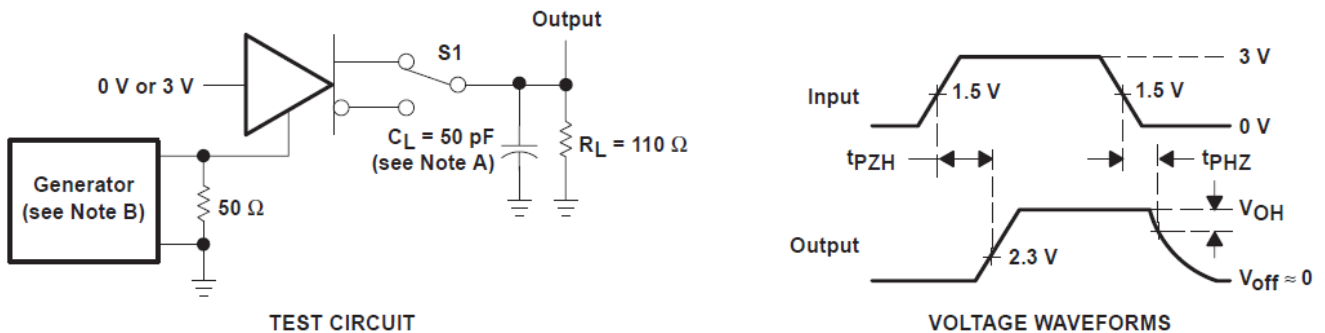


Figure 6-2. Driver  $V_{OD3}$



- A.  $C_L$  includes probe and jig capacitance.
- B. The input pulse is supplied by a generator having the following characteristics:  $PRR \leq 1$  MHz, 50% duty cycle,  $t_r \leq 6$  ns,  $t_f \leq 6$  ns,  $Z_O = 50 \Omega$ .

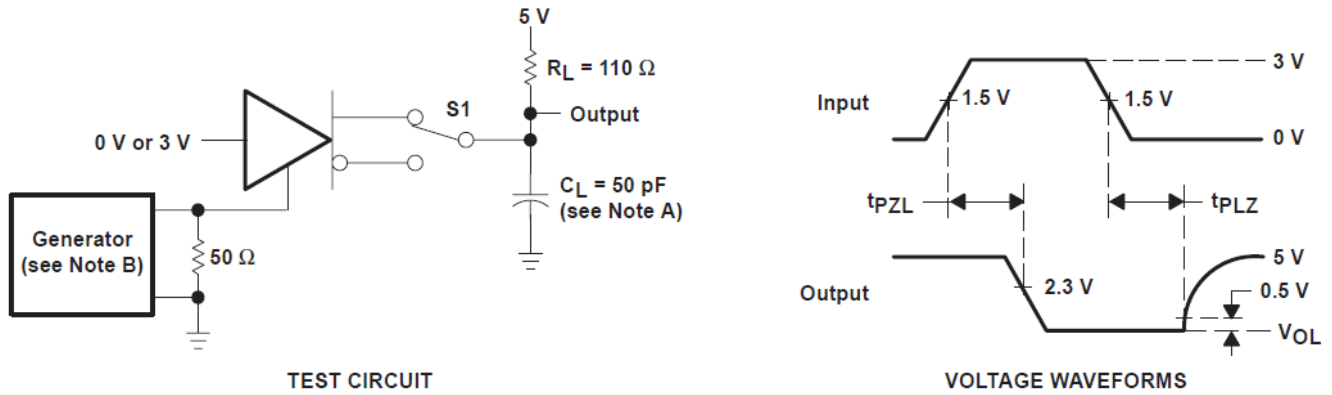
Figure 6-3. Driver Test Circuit and Voltage Waveforms



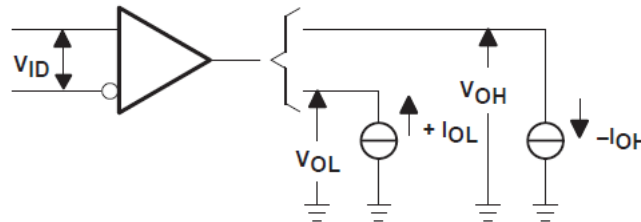
- A.  $C_L$  includes probe and jig capacitance.

- B. The input pulse is supplied by a generator having the following characteristics: PRR  $\leq$  1 MHz, 50% duty cycle,  $t_r \leq$  6 ns,  $t_f \leq$  6 ns,  $Z_O = 50 \Omega$ .

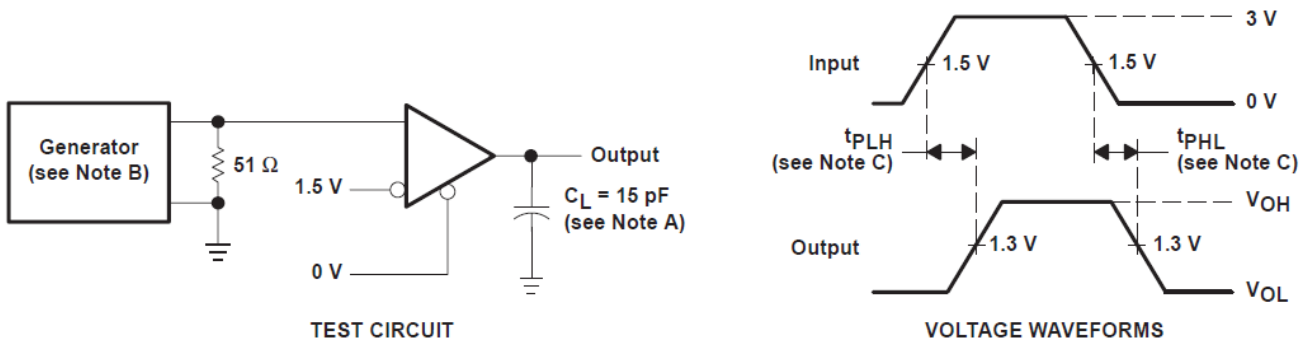
**Figure 6-4. Driver Test Circuit and Voltage Waveforms**



**Figure 6-5. Driver Test Circuit and Voltage Waveforms**

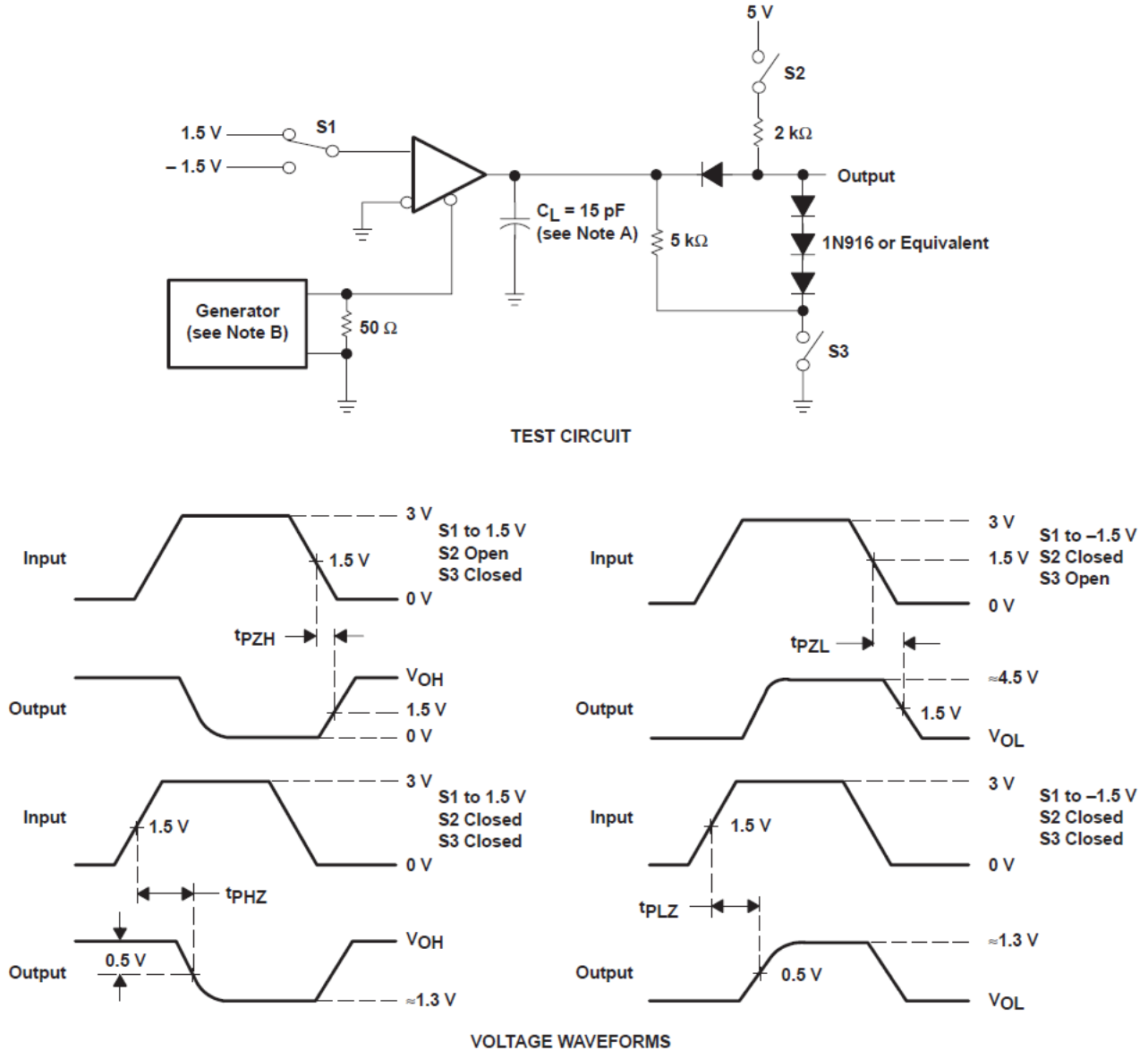


**Figure 6-6. Receiver  $V_{OH}$  and  $V_{OL}$  Test Circuit**



- A.  $C_L$  includes probe and jig capacitance.  
 B. The input pulse is supplied by a generator having the following characteristics: PRR  $\leq$  1 MHz, 50% duty cycle,  $t_r \leq$  6 ns,  $t_f \leq$  6 ns,  $Z_O = 50 \Omega$ .  
 C.  $t_{pd} = t_{PLH}$  or  $t_{PHL}$ .

**Figure 6-7. Receiver Test Circuit and Voltage Waveforms**



- A.  $C_L$  includes probe and jig capacitance.
- B. The input pulse is supplied by a generator having the following characteristics:  $PRR \leq 1$  MHz, 50% duty cycle,  $t_r \leq 6$  ns,  $t_f \leq 6$  ns,  $Z_O = 50 \Omega$ .

**Figure 6-8. Receiver Test Circuit and Voltage Waveforms**

## 7 Detailed Description

### 7.1 Functional Block Diagram

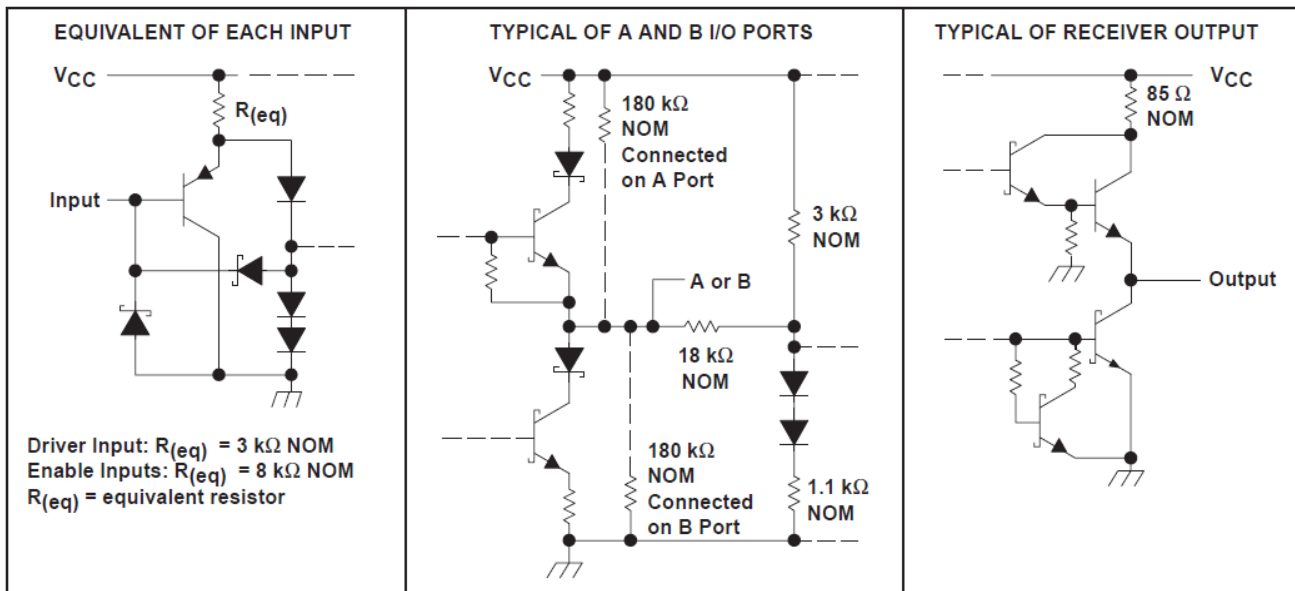


Figure 7-1. Schematic of Inputs and Outputs

### 7.2 Device Functional Modes

#### Function Tables

Table 7-1. Driver<sup>(1)</sup>

INPUT D	ENABLE DE	OUTPUTS	
		A	B
H	H	H	L
L	H	L	H
X	L	Z	Z

(1) H = high level, L = low level, X = irrelevant, Z = high impedance

Table 7-2. Receiver<sup>(1)</sup>

DIFFERENTIAL INPUTS A-B	ENABLE RE	OUTPUT R
$V_{ID} \geq 0.2 \text{ V}$	L	H
$-0.2 \text{ V} < V_{ID} < 0.2 \text{ V}$	L	?
$V_{ID} \leq -0.2 \text{ V}$	L	L
X	H	Z
Inputs open	L	H

(1) H = high level, L = low level, X = irrelevant, Z = high impedance

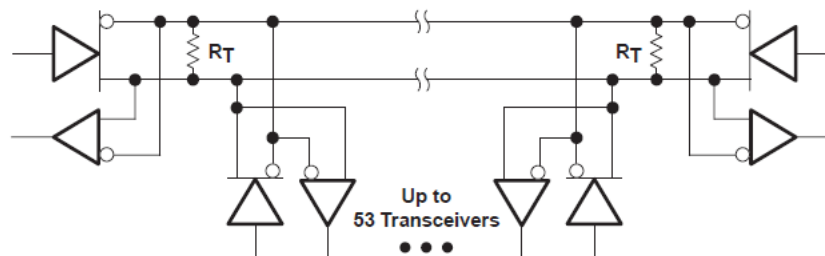
## 8 Application and Implementation

### Note

Information in the following applications sections is not part of the TI component specification, and TI does not warrant its accuracy or completeness. TI's customers are responsible for determining suitability of components for their purposes, as well as validating and testing their design implementation to confirm system functionality.

### 8.1 Application Information

### 8.2 Typical Application



- A. The line should terminate at both ends in its characteristic impedance ( $R_T = Z_0$ ). Stub lengths off the main line should be kept as short as possible.

**Figure 8-1. Typical Application Circuit**

## 9 Device and Documentation Support

TI offers an extensive line of development tools. Tools and software to evaluate the performance of the device, generate code, and develop solutions are listed below.

### 9.1 Documentation Support

#### 9.1.1 Related Documentation

### 9.2 Receiving Notification of Documentation Updates

To receive notification of documentation updates, navigate to the device product folder on [ti.com](http://ti.com). Click on *Subscribe to updates* to register and receive a weekly digest of any product information that has changed. For change details, review the revision history included in any revised document.

### 9.3 Support Resources

[TI E2E™ support forums](#) are an engineer's go-to source for fast, verified answers and design help — straight from the experts. Search existing answers or ask your own question to get the quick design help you need.

Linked content is provided "AS IS" by the respective contributors. They do not constitute TI specifications and do not necessarily reflect TI's views; see TI's [Terms of Use](#).

### 9.4 Trademarks

TI E2E™ is a trademark of Texas Instruments.  
All trademarks are the property of their respective owners.

### 9.5 Electrostatic Discharge Caution



This integrated circuit can be damaged by ESD. Texas Instruments recommends that all integrated circuits be handled with appropriate precautions. Failure to observe proper handling and installation procedures can cause damage.

ESD damage can range from subtle performance degradation to complete device failure. Precision integrated circuits may be more susceptible to damage because very small parametric changes could cause the device not to meet its published specifications.

### 9.6 Glossary

[TI Glossary](#) This glossary lists and explains terms, acronyms, and definitions.

## 10 Mechanical, Packaging, and Orderable Information

The following pages include mechanical, packaging, and orderable information. This information is the most current data available for the designated devices. This data is subject to change without notice and revision of this document. For browser-based versions of this data sheet, refer to the left-hand navigation.

**PACKAGING INFORMATION**

Orderable Device	Status (1)	Package Type	Package Drawing	Pins	Package Qty	Eco Plan (2)	Lead finish/ Ball material (6)	MSL Peak Temp (3)	Op Temp (°C)	Device Marking (4/5)	Samples
SN65ALS176DR	ACTIVE	SOIC	D	8	2500	RoHS & Green	NIPDAU	Level-1-260C-UNLIM	-40 to 85	65A176	<a href="#">Samples</a>
SN75ALS176AD	ACTIVE	SOIC	D	8	75	RoHS & Green	NIPDAU	Level-1-260C-UNLIM	0 to 70	7A176A	<a href="#">Samples</a>
SN75ALS176ADR	ACTIVE	SOIC	D	8	2500	RoHS & Green	NIPDAU	Level-1-260C-UNLIM	0 to 70	7A176A	<a href="#">Samples</a>
SN75ALS176ADRG4	ACTIVE	SOIC	D	8	2500	RoHS & Green	NIPDAU	Level-1-260C-UNLIM	0 to 70	7A176A	<a href="#">Samples</a>
SN75ALS176AP	ACTIVE	PDIP	P	8	50	RoHS & Green	NIPDAU	N / A for Pkg Type	0 to 70	75ALS176A	<a href="#">Samples</a>
SN75ALS176BDR	ACTIVE	SOIC	D	8	2500	RoHS & Green	NIPDAU	Level-1-260C-UNLIM	0 to 70	(75A176, 7A176B)	<a href="#">Samples</a>
SN75ALS176BP	ACTIVE	PDIP	P	8	50	RoHS & Green	NIPDAU	N / A for Pkg Type	0 to 70	75ALS176B	<a href="#">Samples</a>
SN75ALS176P	ACTIVE	PDIP	P	8	50	RoHS & Green	NIPDAU	N / A for Pkg Type	0 to 70	75ALS176	<a href="#">Samples</a>
SN75ALS176PE4	ACTIVE	PDIP	P	8	50	RoHS & Green	NIPDAU	N / A for Pkg Type	0 to 70	75ALS176	<a href="#">Samples</a>

(1) The marketing status values are defined as follows:

**ACTIVE:** Product device recommended for new designs.

**LIFEBUY:** TI has announced that the device will be discontinued, and a lifetime-buy period is in effect.

**NRND:** Not recommended for new designs. Device is in production to support existing customers, but TI does not recommend using this part in a new design.

**PREVIEW:** Device has been announced but is not in production. Samples may or may not be available.

**OBSELETE:** TI has discontinued the production of the device.

(2) **RoHS:** TI defines "RoHS" to mean semiconductor products that are compliant with the current EU RoHS requirements for all 10 RoHS substances, including the requirement that RoHS substance do not exceed 0.1% by weight in homogeneous materials. Where designed to be soldered at high temperatures, "RoHS" products are suitable for use in specified lead-free processes. TI may reference these types of products as "Pb-Free".

**RoHS Exempt:** TI defines "RoHS Exempt" to mean products that contain lead but are compliant with EU RoHS pursuant to a specific EU RoHS exemption.

**Green:** TI defines "Green" to mean the content of Chlorine (Cl) and Bromine (Br) based flame retardants meet JS709B low halogen requirements of <=1000ppm threshold. Antimony trioxide based flame retardants must also meet the <=1000ppm threshold requirement.

(3) MSL, Peak Temp. - The Moisture Sensitivity Level rating according to the JEDEC industry standard classifications, and peak solder temperature.

(4) There may be additional marking, which relates to the logo, the lot trace code information, or the environmental category on the device.

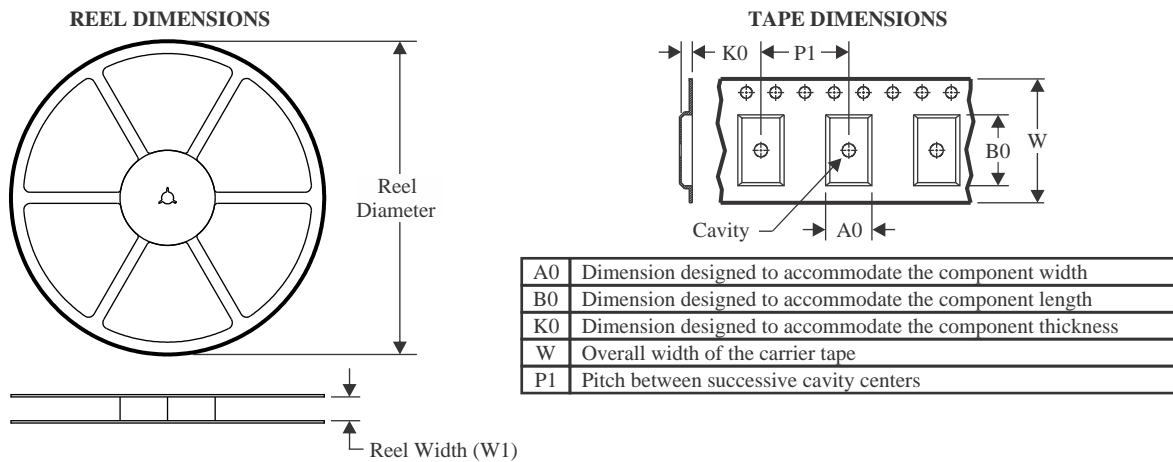
(5) Multiple Device Markings will be inside parentheses. Only one Device Marking contained in parentheses and separated by a "~" will appear on a device. If a line is indented then it is a continuation of the previous line and the two combined represent the entire Device Marking for that device.

(6) Lead finish/Ball material - Orderable Devices may have multiple material finish options. Finish options are separated by a vertical ruled line. Lead finish/Ball material values may wrap to two lines if the finish value exceeds the maximum column width.

**Important Information and Disclaimer:**The information provided on this page represents TI's knowledge and belief as of the date that it is provided. TI bases its knowledge and belief on information provided by third parties, and makes no representation or warranty as to the accuracy of such information. Efforts are underway to better integrate information from third parties. TI has taken and continues to take reasonable steps to provide representative and accurate information but may not have conducted destructive testing or chemical analysis on incoming materials and chemicals. TI and TI suppliers consider certain information to be proprietary, and thus CAS numbers and other limited information may not be available for release.

In no event shall TI's liability arising out of such information exceed the total purchase price of the TI part(s) at issue in this document sold by TI to Customer on an annual basis.

## TAPE AND REEL INFORMATION



### QUADRANT ASSIGNMENTS FOR PIN 1 ORIENTATION IN TAPE



\*All dimensions are nominal

Device	Package Type	Package Drawing	Pins	SPQ	Reel Diameter (mm)	Reel Width W1 (mm)	A0 (mm)	B0 (mm)	K0 (mm)	P1 (mm)	W (mm)	Pin1 Quadrant
SN65ALS176DR	SOIC	D	8	2500	330.0	12.4	6.4	5.2	2.1	8.0	12.0	Q1
SN75ALS176ADR	SOIC	D	8	2500	330.0	12.4	6.4	5.2	2.1	8.0	12.0	Q1
SN75ALS176BDR	SOIC	D	8	2500	330.0	12.4	6.4	5.2	2.1	8.0	12.0	Q1

**TAPE AND REEL BOX DIMENSIONS**


\*All dimensions are nominal

Device	Package Type	Package Drawing	Pins	SPQ	Length (mm)	Width (mm)	Height (mm)
SN65ALS176DR	SOIC	D	8	2500	356.0	356.0	35.0
SN75ALS176ADR	SOIC	D	8	2500	340.5	336.1	25.0
SN75ALS176BDR	SOIC	D	8	2500	356.0	356.0	35.0

**TUBE**


\*All dimensions are nominal

Device	Package Name	Package Type	Pins	SPQ	L (mm)	W (mm)	T (μm)	B (mm)
SN75ALS176AD	D	SOIC	8	75	507	8	3940	4.32
SN75ALS176AP	P	PDIP	8	50	506	13.97	11230	4.32
SN75ALS176BP	P	PDIP	8	50	506	13.97	11230	4.32
SN75ALS176P	P	PDIP	8	50	506	13.97	11230	4.32
SN75ALS176PE4	P	PDIP	8	50	506	13.97	11230	4.32



D0008A

# PACKAGE OUTLINE

SOIC - 1.75 mm max height

SMALL OUTLINE INTEGRATED CIRCUIT



NOTES:

1. Linear dimensions are in inches [millimeters]. Dimensions in parenthesis are for reference only. Controlling dimensions are in inches. Dimensioning and tolerancing per ASME Y14.5M.
2. This drawing is subject to change without notice.
3. This dimension does not include mold flash, protrusions, or gate burrs. Mold flash, protrusions, or gate burrs shall not exceed  $.006$  [0.15] per side.
4. This dimension does not include interlead flash.
5. Reference JEDEC registration MS-012, variation AA.

# EXAMPLE BOARD LAYOUT

D0008A

SOIC - 1.75 mm max height

SMALL OUTLINE INTEGRATED CIRCUIT



LAND PATTERN EXAMPLE  
 EXPOSED METAL SHOWN  
 SCALE:8X



SOLDER MASK DETAILS

4214825/C 02/2019

NOTES: (continued)

- 6. Publication IPC-7351 may have alternate designs.
- 7. Solder mask tolerances between and around signal pads can vary based on board fabrication site.

# EXAMPLE STENCIL DESIGN

D0008A

SOIC - 1.75 mm max height

SMALL OUTLINE INTEGRATED CIRCUIT



SOLDER PASTE EXAMPLE  
BASED ON .005 INCH [0.125 MM] THICK STENCIL  
SCALE:8X

4214825/C 02/2019

NOTES: (continued)

8. Laser cutting apertures with trapezoidal walls and rounded corners may offer better paste release. IPC-7525 may have alternate design recommendations.
9. Board assembly site may have different recommendations for stencil design.

P (R-PDIP-T8)

PLASTIC DUAL-IN-LINE PACKAGE



- NOTES:
- A. All linear dimensions are in inches (millimeters).
  - B. This drawing is subject to change without notice.
  - C. Falls within JEDEC MS-001 variation BA.

## IMPORTANT NOTICE AND DISCLAIMER

TI PROVIDES TECHNICAL AND RELIABILITY DATA (INCLUDING DATA SHEETS), DESIGN RESOURCES (INCLUDING REFERENCE DESIGNS), APPLICATION OR OTHER DESIGN ADVICE, WEB TOOLS, SAFETY INFORMATION, AND OTHER RESOURCES "AS IS" AND WITH ALL FAULTS, AND DISCLAIMS ALL WARRANTIES, EXPRESS AND IMPLIED, INCLUDING WITHOUT LIMITATION ANY IMPLIED WARRANTIES OF MERCHANTABILITY, FITNESS FOR A PARTICULAR PURPOSE OR NON-INFRINGEMENT OF THIRD PARTY INTELLECTUAL PROPERTY RIGHTS.

These resources are intended for skilled developers designing with TI products. You are solely responsible for (1) selecting the appropriate TI products for your application, (2) designing, validating and testing your application, and (3) ensuring your application meets applicable standards, and any other safety, security, regulatory or other requirements.

These resources are subject to change without notice. TI grants you permission to use these resources only for development of an application that uses the TI products described in the resource. Other reproduction and display of these resources is prohibited. No license is granted to any other TI intellectual property right or to any third party intellectual property right. TI disclaims responsibility for, and you will fully indemnify TI and its representatives against, any claims, damages, costs, losses, and liabilities arising out of your use of these resources.

TI's products are provided subject to [TI's Terms of Sale](#) or other applicable terms available either on [ti.com](https://www.ti.com) or provided in conjunction with such TI products. TI's provision of these resources does not expand or otherwise alter TI's applicable warranties or warranty disclaimers for TI products.

TI objects to and rejects any additional or different terms you may have proposed.

Mailing Address: Texas Instruments, Post Office Box 655303, Dallas, Texas 75265  
Copyright © 2024, Texas Instruments Incorporated

## Looking for pricing, stock, or lifecycle information?

Click below to explore more details on WIN SOURCE:

 [View SN65ALS176DR](#) on WIN SOURCE

 [Texas Instruments](#) Information

## Optimize Your Supply Chain with WIN SOURCE Solutions

-  Global Sourcing Solution
-  Obsolete Management
-  Cost Control Management
-  Shortage Management
-  Alternative Solution
-  Excess Inventory Management