



**THE DATASHEET OF
SN65175D**



SNx5175 Quadruple Differential Line Receivers

1 Features

- Meet or exceed the requirements of ANSI standard EIA/TIA-422-B, RS-423-B, and RS-485
- Meet ITU recommendations V.10, V.11, X.26, and X.27
- Designed for multipoint bus transmission on long bus lines in noisy environments
- 3-state outputs
- Common-mode input voltage range: -12 V to 12 V
- Input sensitivity: ±200 mV
- Input hysteresis: 50-mV typical
- High input impedance: 12-kΩ minimum
- Operate from single 5-V supply
- Low-power requirements
- Plug-in replacement for MC3486

2 Applications

- Motor drives
- Factory automation and control

3 Description

The SN65175 and SN75175 are monolithic quadruple differential line receivers with 3-state outputs. They are designed to meet the requirements of ANSI Standards EIA/TIA-422-B, RS-423-B, and RS-485, and several ITU recommendations. These standards are for balanced multipoint bus transmission at rates up to 10 megabits per second. Each of the two pairs of receivers has a common active-high enable.

The receivers feature high input impedance, input hysteresis for increased noise immunity, and input sensitivity of ±200 mV over a common-mode input voltage range of ±12 V. The SN65175 and SN75175 are designed for optimum performance when used with the SN75172 or SN75174 quadruple differential line drivers.

The SN65175 is characterized for operation from -40°C to 85°C. The SN75175 is characterized for operation from 0°C to 70°C.

Package Information

PART NUMBER	PACKAGE ⁽¹⁾	PACKAGE SIZE ⁽²⁾
SN65175	D (SOIC, 16)	9.9 mm × 6 mm
SN75175	N (PDIP, 16)	19.3 mm × 9.4 mm
	D (SOIC, 16)	9.9 mm × 6 mm
	NS (SOP, 16)	10.2 mm × 7.8 mm

(1) For all more information, see [Section 11](#).

(2) The package size (length × width) is a nominal value and includes pins, where applicable.

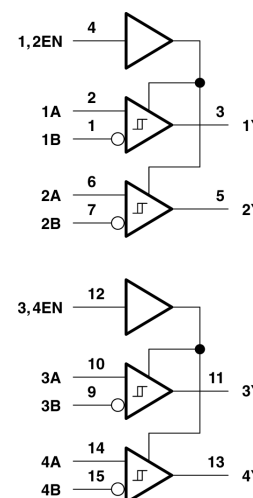
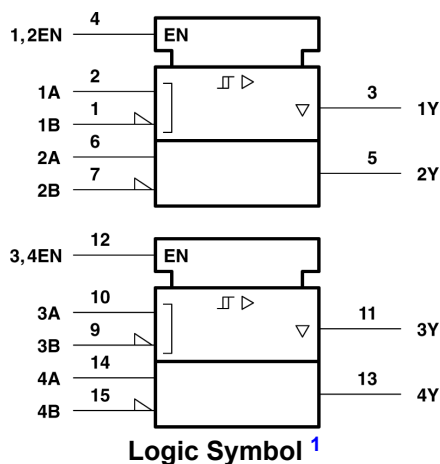

¹ This symbol is in accordance with ANSI/IEEE Std 91-1984 and IEC Publication 617-12.



Table of Contents

1 Features	1	7 Detailed Description	11
2 Applications	1	7.1 Device Functional Modes.....	11
3 Description	1	8 Application and Implementation	12
4 Pin Configuration and Functions	3	8.1 Application Information.....	12
5 Specifications	4	9 Device and Documentation Support	13
5.1 Absolute Maximum Ratings.....	4	9.1 Receiving Notification of Documentation Updates....	13
5.2 Dissipation Rating.....	4	9.2 Support Resources.....	13
5.3 Recommended Operating Conditions.....	4	9.3 Trademarks.....	13
5.4 Thermal Information.....	5	9.4 Electrostatic Discharge Caution.....	13
5.5 Electrical Characteristics.....	5	9.5 Glossary.....	13
5.6 Switching Characteristics.....	6	10 Revision History	13
5.7 Typical Characteristics.....	7	11 Mechanical, Packaging, and Orderable	
6 Parameter Measurement Information	9	Information	13

4 Pin Configuration and Functions

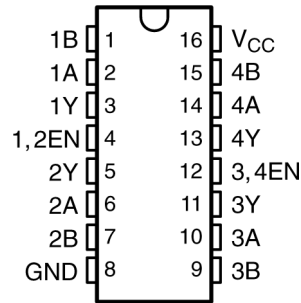

Figure 4-1. D, N, or NS Package (Top View)

Table 4-1. Pin Functions

PIN		TYPE ⁽¹⁾	DESCRIPTION
NAME	NO.		
1B	1	I	Channel 1 Differential Receiver Inverting Input
1A	2	I	Channel 1 Differential Receiver Non-Inverting Input
1Y	3	O	Channel 1 Single Ended Output
1,2EN	4	I	Active High Enable for Channels 1 and 2
2Y	5	O	Channel 2 Single Ended Output
2A	6	I	Channel 2 Differential Receiver Non-Inverting Input
2B	7	I	Channel 2 Differential Receiver Inverting Input
GND	8	GND	Device GND
3B	9	I	Channel 3 Differential Receiver Inverting Input
3A	10	I	Channel 3 Differential Receiver Non-Inverting Input
3Y	11	O	Channel 3 Single Ended Output
3,4EN	12	I	Active High Enable for Channels 3 and 4
4Y	13	O	Channel 4 Single Ended Output
4A	14	I	Channel 4 Differential Receiver Non-Inverting Input
4B	15	I	Channel 4 Differential Receiver Inverting Input
V _{CC}	16	PWR	Device V _{CC} (4.75 V to 5.25 V)

(1) Signal Types: I = Input, O = Output, I/O = Input or Output.

5 Specifications

5.1 Absolute Maximum Ratings

over operating free-air temperature range (unless otherwise noted)⁽¹⁾

		MIX	MAX	UNIT	
V_{CC} ⁽²⁾	Supply voltage		7	V	
V_I	Input voltage (A or B inputs)		±25	V	
V_{ID} ⁽³⁾	Differential input voltage		±25	V	
$V_{I(EN)}$	Enable input voltage		7	V	
I_{OL}	Low-level output current		50	mA	
Continuous total dissipation		See <i>Dissipation Rating</i> table			
T_A	Operating free-air temperature range:	SN65175	-40	85	°C
		SN75175	0	70	°C
	Lead temperature 1,6 mm (1/16 inch) from case for 10 seconds		260	°C	
T_{stg}	Storage temperature range	-65	150	°C	

- (1) Stresses beyond those listed under “absolute maximum ratings” may cause permanent damage to the device. These are stress ratings only, and functional operation of the device at these or any other conditions beyond those indicated under “recommended operating conditions” is not implied. Exposure to absolute-maximum-rated conditions for extended periods may affect device reliability.
- (2) All voltage values, except differential input voltage, are with respect to network ground terminal.
- (3) Differential-input voltage is measured at the noninverting input with respect to the corresponding inverting input.

5.2 Dissipation Rating

PACKAGE	$T_A \leq 25^\circ\text{C}$ POWER RATING	DERATING FACTOR	$T_A = 70^\circ\text{C}$ POWER RATING	$T_A = 85^\circ\text{C}$ POWER RATING
D	950 mW	7.6 mW/°C	608 mW	494 mW
N	1150 mW	9.2 mW/°C	736 mW	598 mW

5.3 Recommended Operating Conditions

		MIN	NOM	MAX	UNIT
Supply voltage, V_{CC}		4.75	5	5.25	V
Common-mode input voltage, V_{IC}				±12	V
Differential input voltage, V_{ID}				±12	V
High-level enable-input voltage, V_{IH}		2			V
Low-level enable-input voltage, V_{IL}				0.8	V
High-level output current, I_{OH}				-400	µA
Low-level output current, I_{OL}				16	mA
Operating free-air temperature, T_A	SN65175	-40		85	°C
	SN75175	0		70	

5.4 Thermal Information

THERMAL METRIC ⁽¹⁾		D (SOIC)	N (PDIP)	NS (SOP)	UNIT
		16-PINS			
$R_{\theta JA}$	Junction-to-ambient thermal resistance	84.6	60.6	88.5	°C/W
$R_{\theta JC(top)}$	Junction-to-case (top) thermal resistance	43.5	48.1	46.2	°C/W
$R_{\theta JB}$	Junction-to-board thermal resistance	43.2	40.6	50.7	°C/W
Ψ_{JT}	Junction-to-top characterization parameter	10.4	27.5	13.5	°C/W
Ψ_{JB}	Junction-to-board characterization parameter	42.8	40.3	50.3	°C/W
$R_{\theta JC(bot)}$	Junction-to-case (bottom) thermal resistance	n/a	n/a	n/a	°C/W

- (1) For more information about traditional and new thermal metrics, see the [Semiconductor and IC package thermal metrics](#) application report.

5.5 Electrical Characteristics

over recommended ranges of common-mode input voltage, supply voltage and operating free-air temperature

PARAMETER		TEST CONDITIONS		MIN	TYP ⁽¹⁾	MAX	UNIT
V_{IT+}	Positive-going input threshold voltage	$V_O = 2.7\text{ V}$,	$I_O = -0.4\text{ mA}$			0.2	V
V_{IT-}	Negative-going input threshold voltage	$V_O = 0.5\text{ V}$,	$I_O = 16\text{ mA}$	-0.2 ⁽²⁾			V
V_{hys}	Hysteresis voltage ($V_{IT+} - V_{IT-}$)	See Figure 5-1			50		mV
V_{IK}	Enable-input clamp voltage	$I_I = -18\text{ mA}$				-1.5	V
V_{OH}	High-level output voltage	$V_{ID} = 200\text{ mV}$,	$I_{OH} = -400\text{ }\mu\text{A}$,	See Figure 6-1		2.7	V
V_{OL}	Low-level output voltage	$V_{ID} = -200\text{ mV}$,	See Figure 6-1	$I_{OL} = 8\text{ mA}$		0.45	V
				$I_{OL} = 16\text{ mA}$		0.5	
I_{OZ}	High-impedance-state output current	$V_O = 0.4\text{ V to }2.4\text{ V}$				± 20	μA
I_I	Line input current	Other input at 0 V,	See ⁽⁴⁾	$V_I = 12\text{ V}$		1	mA
				$V_I = -7\text{ V}$		-0.8	
I_{IH}	High-level enable-input current	$V_{IH} = 2.7\text{ V}$				20	μA
I_{IL}	Low-level enable-input current	$V_{IL} = 0.4\text{ V}$				-100	μA
r_i	Input resistance			12			k Ω
I_{OS}	Short-circuit output current ⁽³⁾			-15		-85	mA
I_{CC}	Supply current	Outputs disabled				70	mA

- (1) All typical values are at $V_{CC} = 5\text{ V}$, $T_A = 25^\circ\text{C}$.
(2) The algebraic convention, in which the less positive (more negative) limit is designated as minimum, is used in this data sheet for threshold voltage levels only.
(3) Not more than one output should be shorted at a time, and the duration of the short circuit should not exceed one second.
(4) Refer to ANSI Standards EIA/TIA-422-B, RS-423-B, and RS-485 for exact conditions.

5.6 Switching Characteristics

$V_{CC} = 5\text{ V}$, $C_L = 15\text{ pF}$, $T_A = 25^\circ\text{C}$

PARAMETER		TEST CONDITIONS	MIN	TYP	MAX	UNIT
t_{PLH}	Propagation delay time, low- to high-level output	See Figure 6-2		22	35	ns
t_{PHL}	Propagation delay time, high- to low-level output			25	35	ns
t_{PZH}	Output enable time to high level	See Figure 6-3		13	30	ns
t_{PZL}	Output enable time to low level			19	30	ns
t_{PHZ}	Output disable time from high level	See Figure 6-3		26	35	ns
t_{PLZ}	Output disable time from low level			25	35	ns

5.7 Typical Characteristics

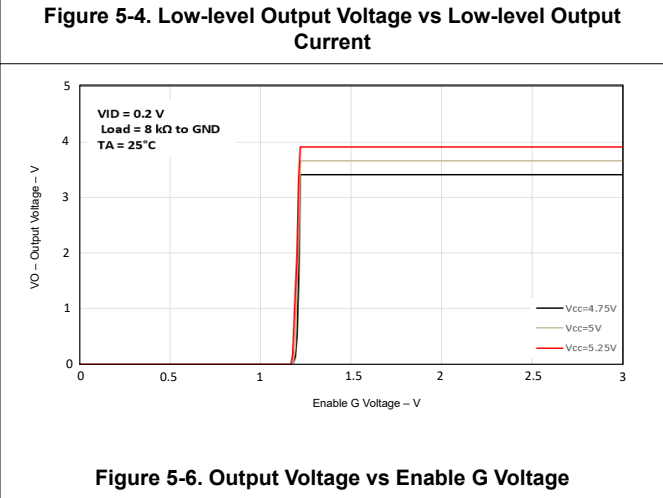
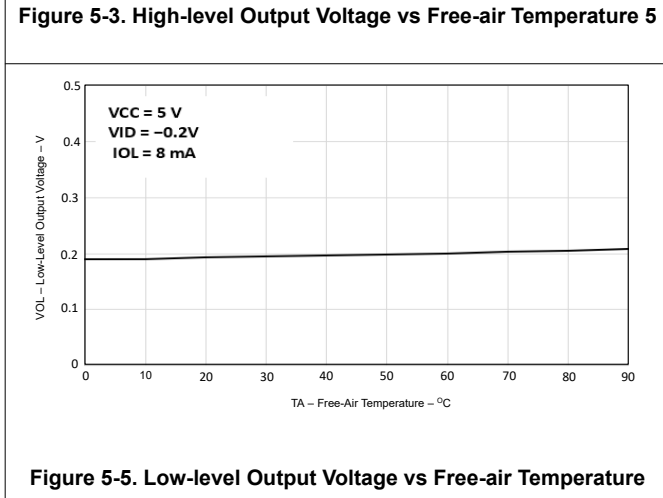
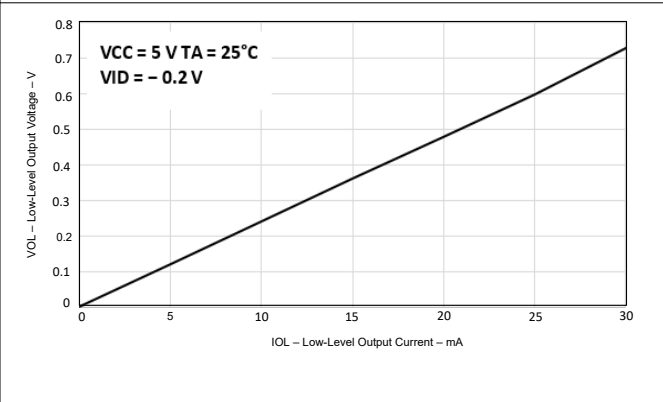
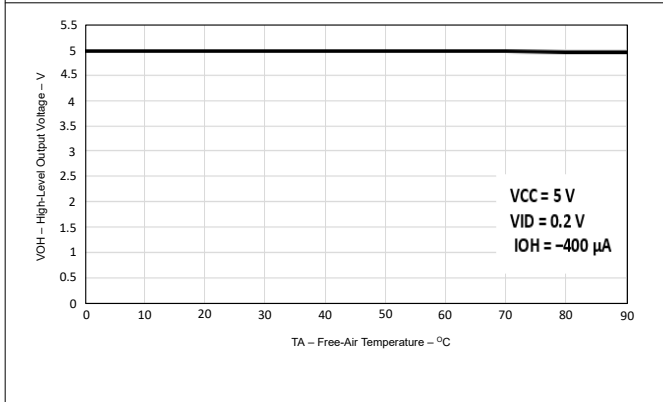
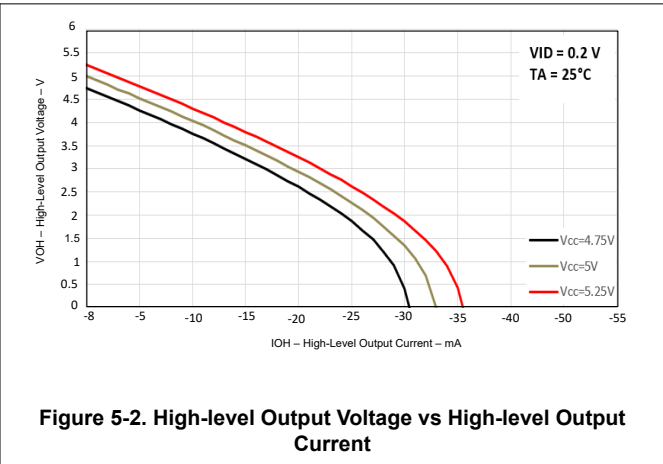
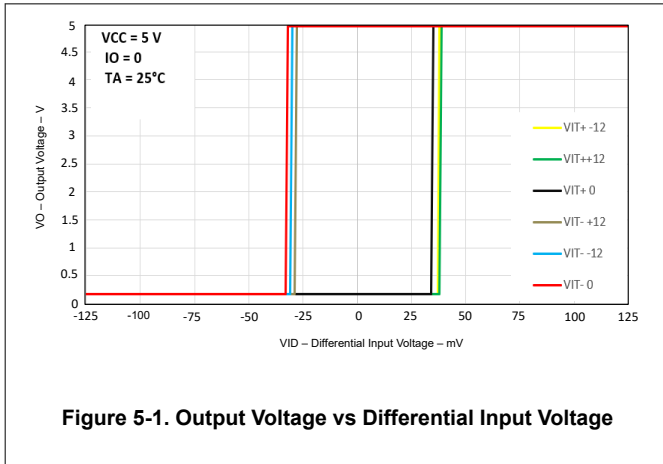

5.7 Typical Characteristics (continued)

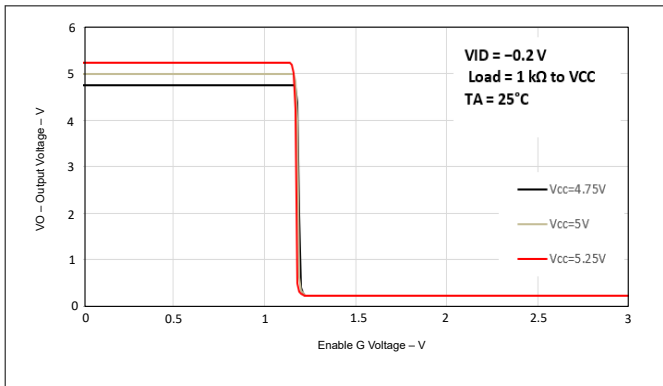

Figure 5-7. Output Voltage vs Enable G Voltage

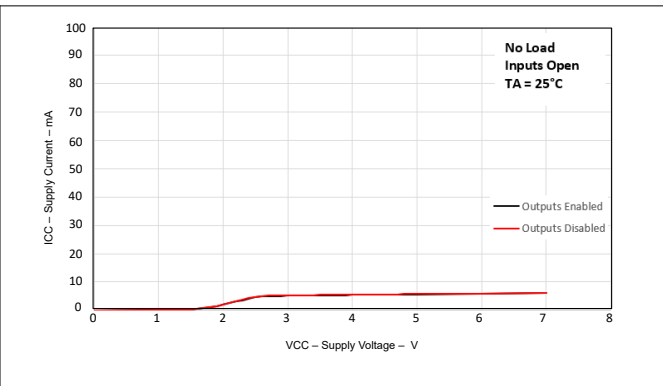

Figure 5-8. Supply Current (All Receivers) vs Supply Voltage

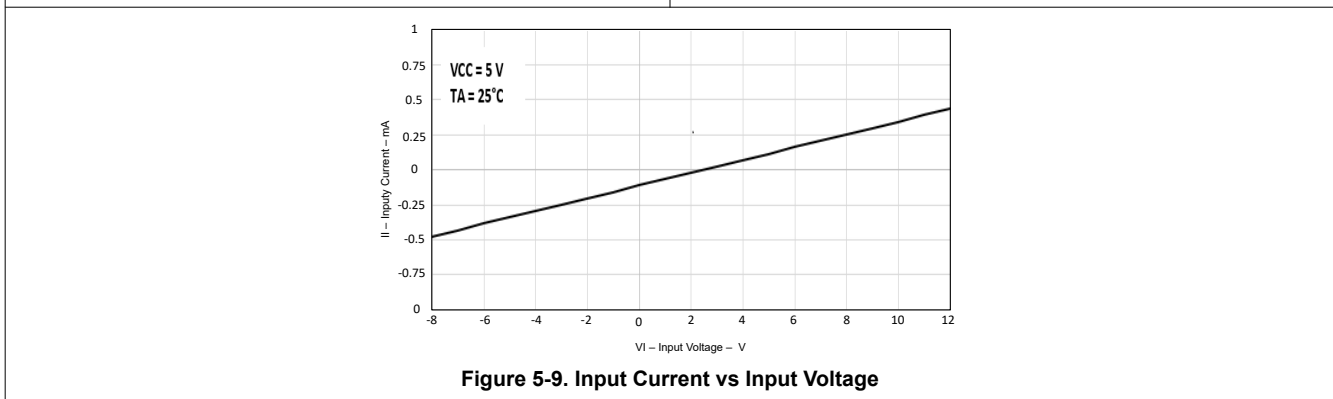

Figure 5-9. Input Current vs Input Voltage

6 Parameter Measurement Information

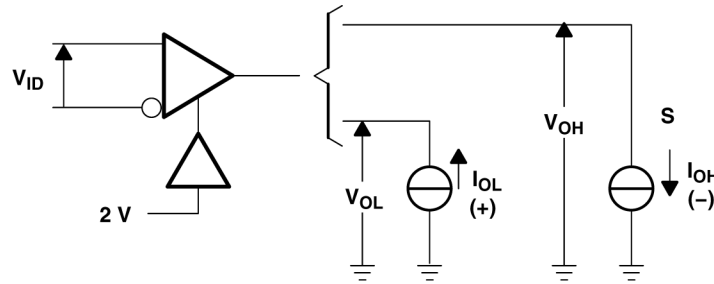
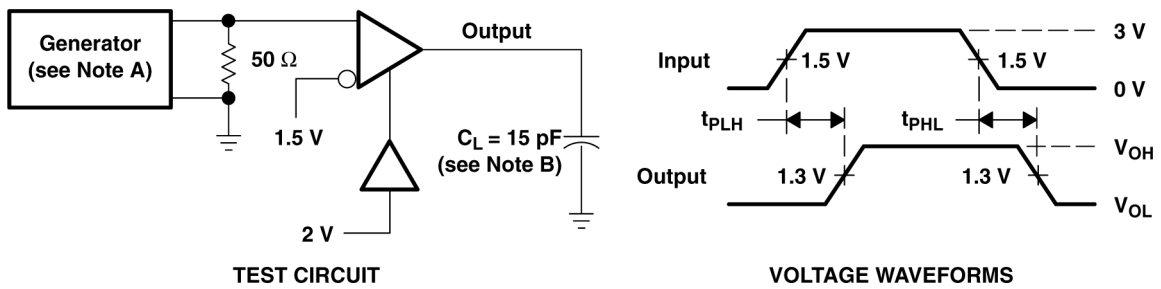

Figure 6-1. V_{OH} , V_{OL}



TEST CIRCUIT

VOLTAGE WAVEFORMS

- A. The input pulse is supplied by a generator having the following characteristics: $PRR \leq 1 \text{ MHz}$, duty cycle = 50%, $t_r \leq 6 \text{ ns}$, $t_f \leq 6 \text{ ns}$, $Z_O = 50 \Omega$.
- B. C_L includes probe and stray capacitance.

Figure 6-2. Test Circuit and Voltage Waveforms

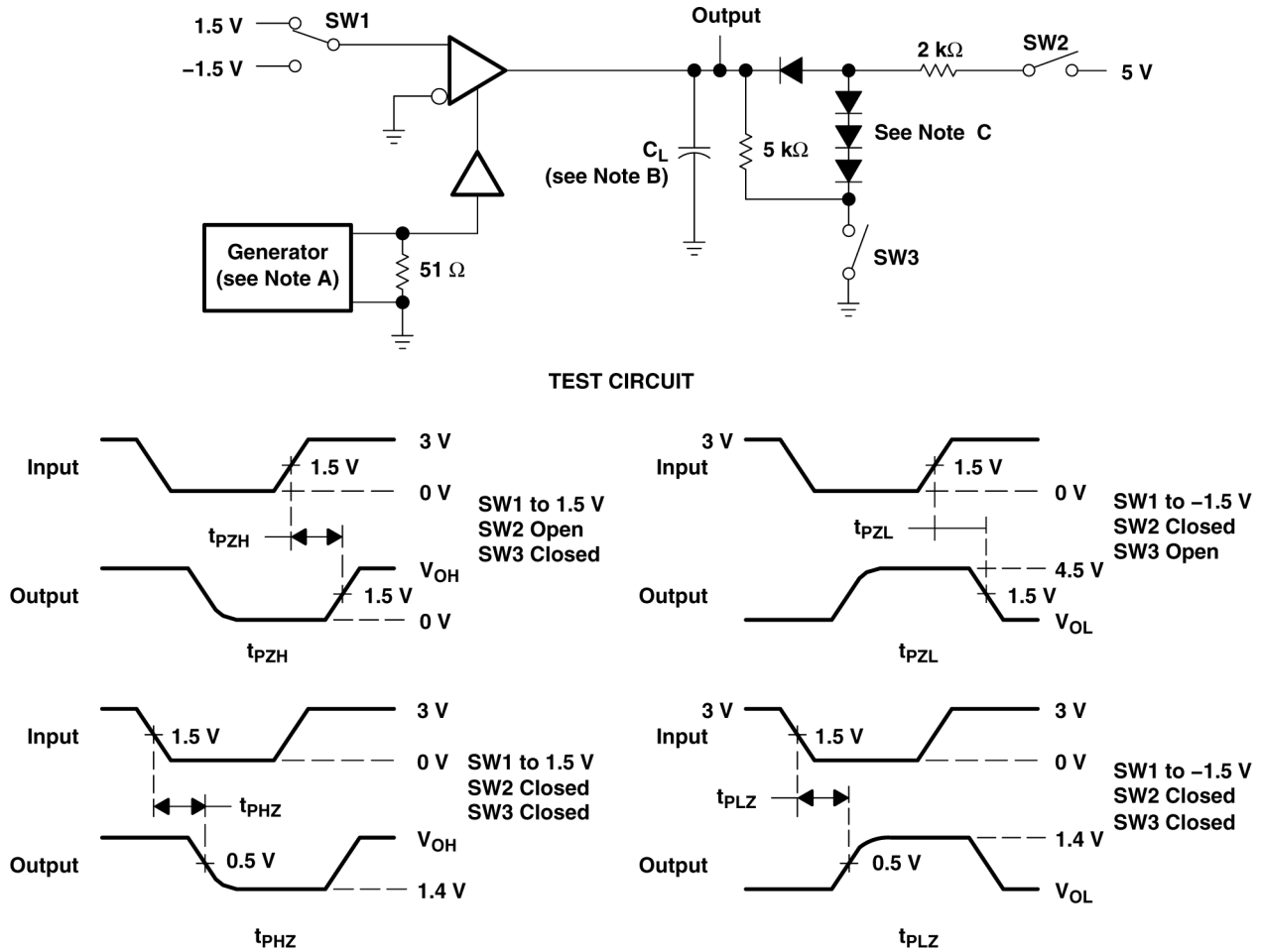

- A. The input pulse is supplied by a generator having the following characteristics: $PRR \leq 1 \text{ MHz}$, duty cycle = 50%, $t_r \leq 6 \text{ ns}$, $t_f \leq 6 \text{ ns}$, $Z_O = 50 \Omega$.
- B. C_L includes probe and stray capacitance.
- C. All diodes are 1N916 or equivalent.

Figure 6-3. Test Circuit and Voltage Waveforms

7 Detailed Description

7.1 Device Functional Modes

Table 7-1. Function Table (Each Receiver)

DIFFERENTIAL A – B ⁽¹⁾	ENABLE	OUTPUT Y
$V_{ID} \geq 0.2 \text{ V}$	H	H
$-0.2 \text{ V} < V_{ID} < 0.2 \text{ V}$	H	?
$V_{ID} \leq -0.2 \text{ V}$	H	L
X	L	Z
Open circuit	H	?

(1) H = high level, L = low level, ? = indeterminate, X = irrelevant, Z = high impedance (off)

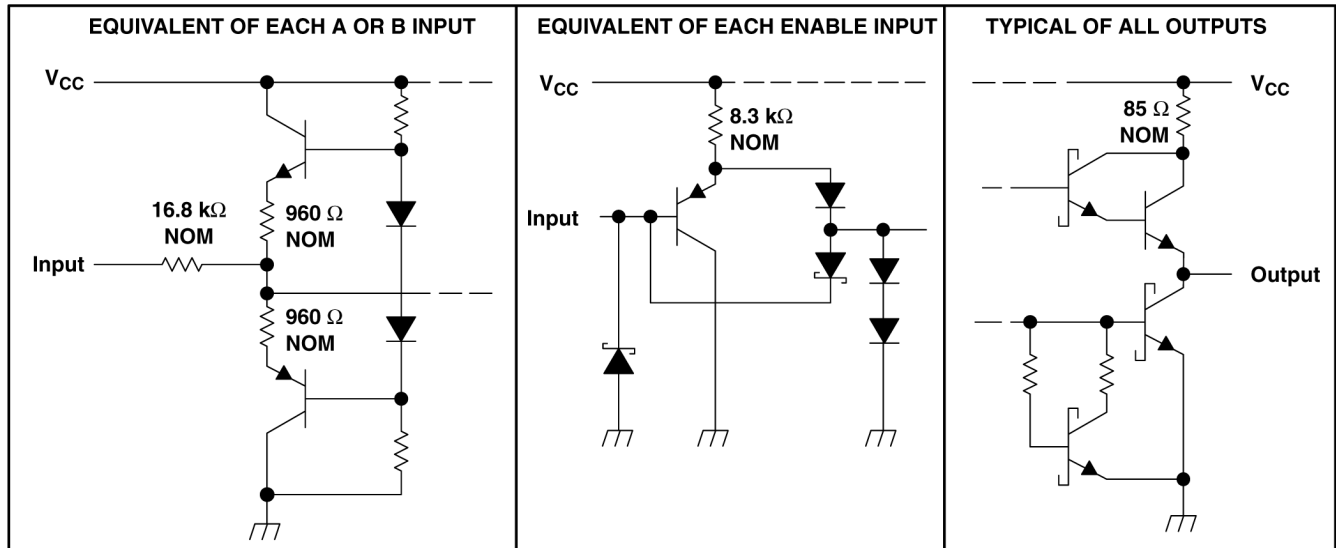

Figure 7-1. Schematics of Inputs and Outputs

8 Application and Implementation

Note

Information in the following applications sections is not part of the TI component specification, and TI does not warrant its accuracy or completeness. TI's customers are responsible for determining suitability of components for their purposes, as well as validating and testing their design implementation to confirm system functionality.

8.1 Application Information

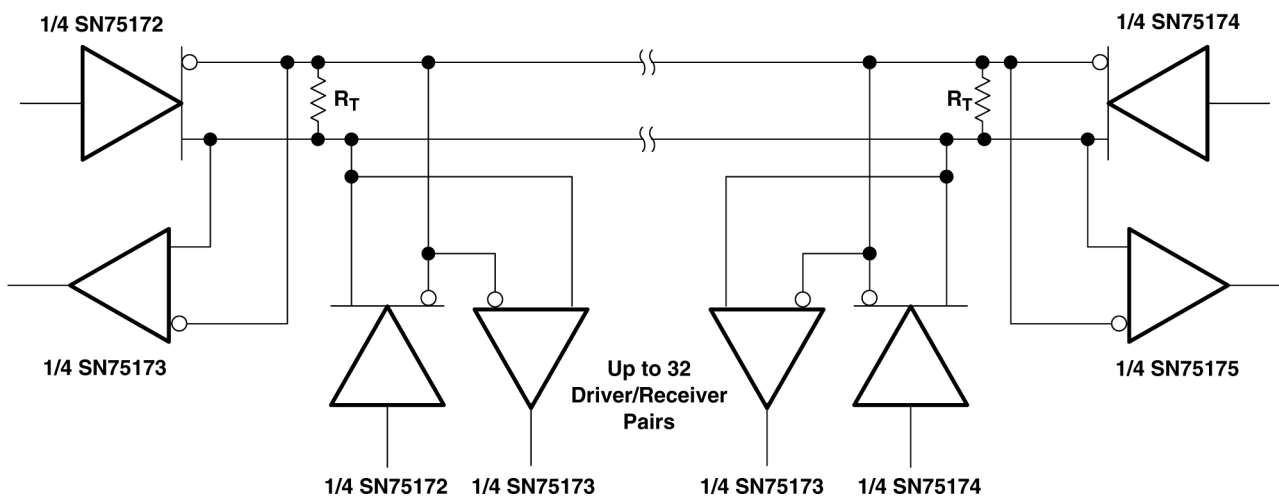

- A. The line should be terminated at both ends in its characteristic impedance ($R_T = Z_0$). Stub lengths off the main line should be kept as short as possible.

Figure 8-1. Typical Application Circuit

9 Device and Documentation Support

TI offers an extensive line of development tools. Tools and software to evaluate the performance of the device, generate code, and develop solutions are listed below.

9.1 Receiving Notification of Documentation Updates

To receive notification of documentation updates, navigate to the device product folder on ti.com. Click on *Subscribe to updates* to register and receive a weekly digest of any product information that has changed. For change details, review the revision history included in any revised document.

9.2 Support Resources

[TI E2E™ support forums](#) are an engineer's go-to source for fast, verified answers and design help — straight from the experts. Search existing answers or ask your own question to get the quick design help you need.

Linked content is provided "AS IS" by the respective contributors. They do not constitute TI specifications and do not necessarily reflect TI's views; see TI's [Terms of Use](#).

9.3 Trademarks

TI E2E™ is a trademark of Texas Instruments.
All trademarks are the property of their respective owners.

9.4 Electrostatic Discharge Caution



This integrated circuit can be damaged by ESD. Texas Instruments recommends that all integrated circuits be handled with appropriate precautions. Failure to observe proper handling and installation procedures can cause damage.

ESD damage can range from subtle performance degradation to complete device failure. Precision integrated circuits may be more susceptible to damage because very small parametric changes could cause the device not to meet its published specifications.

9.5 Glossary

[TI Glossary](#) This glossary lists and explains terms, acronyms, and definitions.

10 Revision History

NOTE: Page numbers for previous revisions may differ from page numbers in the current version.

Changes from Revision C (November 2006) to Revision D (October 2023)	Page
• Changed the numbering format for tables, figures, and cross-references throughout the document.....	1

11 Mechanical, Packaging, and Orderable Information

The following pages include mechanical, packaging, and orderable information. This information is the most current data available for the designated devices. This data is subject to change without notice and revision of this document. For browser-based versions of this data sheet, refer to the left-hand navigation.

PACKAGING INFORMATION

Orderable Device	Status (1)	Package Type	Package Drawing	Pins	Package Qty	Eco Plan (2)	Lead finish/ Ball material (6)	MSL Peak Temp (3)	Op Temp (°C)	Device Marking (4/5)	Samples
SN65175D	ACTIVE	SOIC	D	16	40	RoHS & Green	NIPDAU	Level-1-260C-UNLIM	-40 to 85	SN65175	Samples
SN65175DR	ACTIVE	SOIC	D	16	2500	RoHS & Green	NIPDAU	Level-1-260C-UNLIM	-40 to 85	SN65175	Samples
SN75175D	LIFEBUY	SOIC	D	16	40	RoHS & Green	NIPDAU	Level-1-260C-UNLIM	0 to 70	SN75175	
SN75175DE4	LIFEBUY	SOIC	D	16	40	RoHS & Green	NIPDAU	Level-1-260C-UNLIM	0 to 70	SN75175	
SN75175DR	ACTIVE	SOIC	D	16	2500	RoHS & Green	NIPDAU	Level-1-260C-UNLIM	0 to 70	SN75175	Samples
SN75175N	ACTIVE	PDIP	N	16	25	RoHS & Green	NIPDAU	N / A for Pkg Type	0 to 70	SN75175N	Samples
SN75175NSR	ACTIVE	SO	NS	16	2000	RoHS & Green	NIPDAU	Level-1-260C-UNLIM	0 to 70	SN75175	Samples
SN75175NSRG4	ACTIVE	SO	NS	16	2000	RoHS & Green	NIPDAU	Level-1-260C-UNLIM	0 to 70	SN75175	Samples

(1) The marketing status values are defined as follows:

ACTIVE: Product device recommended for new designs.

LIFEBUY: TI has announced that the device will be discontinued, and a lifetime-buy period is in effect.

NRND: Not recommended for new designs. Device is in production to support existing customers, but TI does not recommend using this part in a new design.

PREVIEW: Device has been announced but is not in production. Samples may or may not be available.

OBSELETE: TI has discontinued the production of the device.

(2) **RoHS:** TI defines "RoHS" to mean semiconductor products that are compliant with the current EU RoHS requirements for all 10 RoHS substances, including the requirement that RoHS substance do not exceed 0.1% by weight in homogeneous materials. Where designed to be soldered at high temperatures, "RoHS" products are suitable for use in specified lead-free processes. TI may reference these types of products as "Pb-Free".

RoHS Exempt: TI defines "RoHS Exempt" to mean products that contain lead but are compliant with EU RoHS pursuant to a specific EU RoHS exemption.

Green: TI defines "Green" to mean the content of Chlorine (Cl) and Bromine (Br) based flame retardants meet JS709B low halogen requirements of <=1000ppm threshold. Antimony trioxide based flame retardants must also meet the <=1000ppm threshold requirement.

(3) MSL, Peak Temp. - The Moisture Sensitivity Level rating according to the JEDEC industry standard classifications, and peak solder temperature.

(4) There may be additional marking, which relates to the logo, the lot trace code information, or the environmental category on the device.

(5) Multiple Device Markings will be inside parentheses. Only one Device Marking contained in parentheses and separated by a "-" will appear on a device. If a line is indented then it is a continuation of the previous line and the two combined represent the entire Device Marking for that device.

⁽⁶⁾ Lead finish/Ball material - Orderable Devices may have multiple material finish options. Finish options are separated by a vertical ruled line. Lead finish/Ball material values may wrap to two lines if the finish value exceeds the maximum column width.

Important Information and Disclaimer:The information provided on this page represents TI's knowledge and belief as of the date that it is provided. TI bases its knowledge and belief on information provided by third parties, and makes no representation or warranty as to the accuracy of such information. Efforts are underway to better integrate information from third parties. TI has taken and continues to take reasonable steps to provide representative and accurate information but may not have conducted destructive testing or chemical analysis on incoming materials and chemicals. TI and TI suppliers consider certain information to be proprietary, and thus CAS numbers and other limited information may not be available for release.

In no event shall TI's liability arising out of such information exceed the total purchase price of the TI part(s) at issue in this document sold by TI to Customer on an annual basis.

TAPE AND REEL INFORMATION



QUADRANT ASSIGNMENTS FOR PIN 1 ORIENTATION IN TAPE



*All dimensions are nominal

Device	Package Type	Package Drawing	Pins	SPQ	Reel Diameter (mm)	Reel Width W1 (mm)	A0 (mm)	B0 (mm)	K0 (mm)	P1 (mm)	W (mm)	Pin1 Quadrant
SN65175DR	SOIC	D	16	2500	330.0	16.4	6.5	10.3	2.1	8.0	16.0	Q1
SN75175DR	SOIC	D	16	2500	330.0	16.4	6.5	10.3	2.1	8.0	16.0	Q1
SN75175DR	SOIC	D	16	2500	330.0	16.4	6.5	10.3	2.1	8.0	16.0	Q1
SN75175NSR	SO	NS	16	2000	330.0	16.4	8.2	10.5	2.5	12.0	16.0	Q1
SN75175NSR	SO	NS	16	2000	330.0	16.4	8.2	10.5	2.5	12.0	16.0	Q1

TAPE AND REEL BOX DIMENSIONS

*All dimensions are nominal

Device	Package Type	Package Drawing	Pins	SPQ	Length (mm)	Width (mm)	Height (mm)
SN65175DR	SOIC	D	16	2500	340.5	336.1	32.0
SN75175DR	SOIC	D	16	2500	353.0	353.0	32.0
SN75175DR	SOIC	D	16	2500	356.0	356.0	35.0
SN75175NSR	SO	NS	16	2000	356.0	356.0	35.0
SN75175NSR	SO	NS	16	2000	353.0	353.0	32.0

TUBE

*All dimensions are nominal

Device	Package Name	Package Type	Pins	SPQ	L (mm)	W (mm)	T (μm)	B (mm)
SN65175D	D	SOIC	16	40	507	8	3940	4.32
SN75175D	D	SOIC	16	40	507	8	3940	4.32
SN75175DE4	D	SOIC	16	40	507	8	3940	4.32
SN75175N	N	PDIP	16	25	506	13.97	11230	4.32



PACKAGE OUTLINE

NS0016A

SOP - 2.00 mm max height

SOP

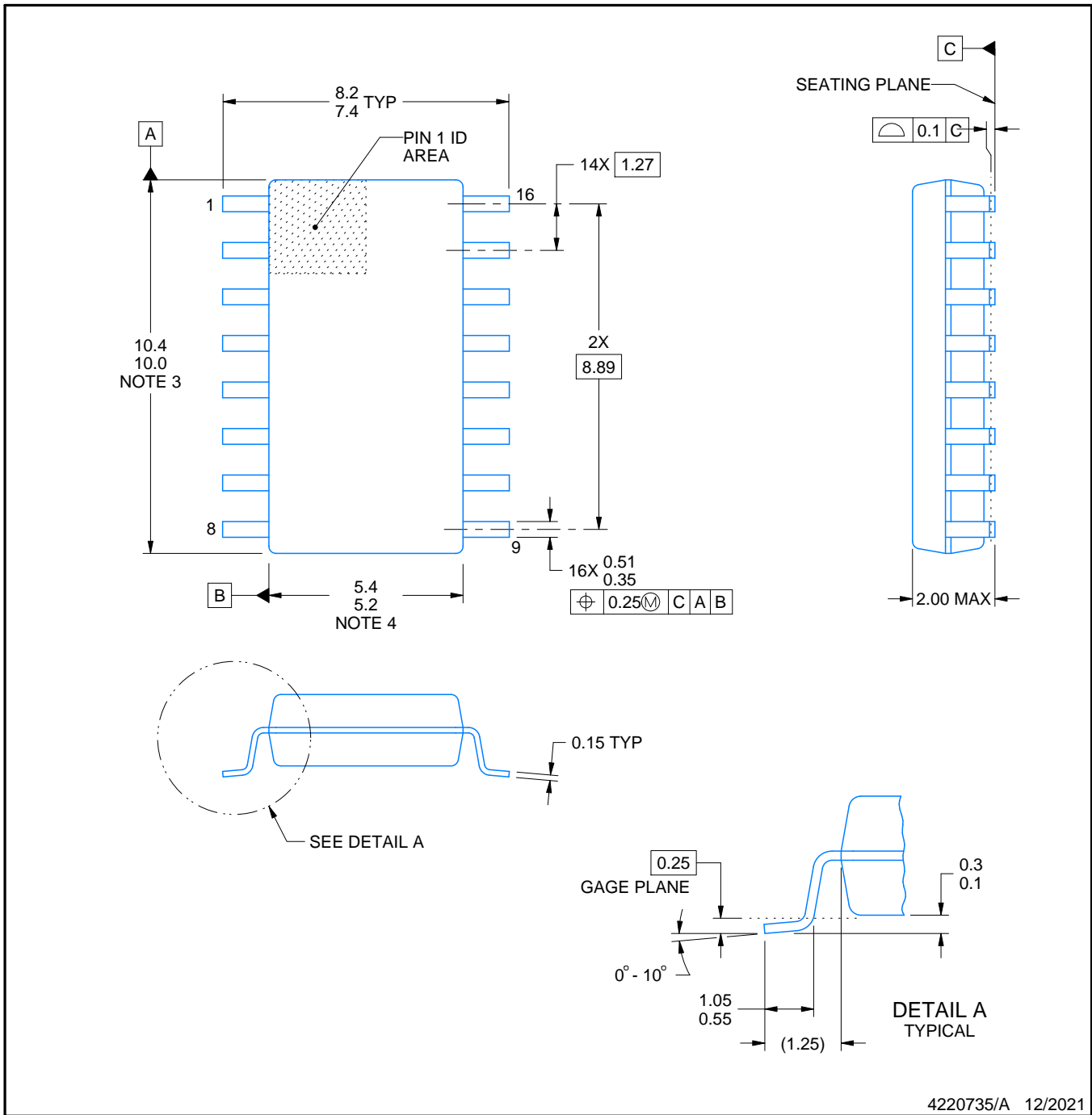

4220735/A 12/2021

NOTES:

- All linear dimensions are in millimeters. Dimensions in parenthesis are for reference only. Dimensioning and tolerancing per ASME Y14.5M.
- This drawing is subject to change without notice.
- This dimension does not include mold flash, protrusions, or gate burrs. Mold flash, protrusions, or gate burrs shall not exceed 0.15 mm, per side.
- This dimension does not include interlead flash. Interlead flash shall not exceed 0.25 mm, per side.

EXAMPLE BOARD LAYOUT

NS0016A

SOP - 2.00 mm max height

SOP



SOLDER MASK DETAILS

4220735/A 12/2021

NOTES: (continued)

5. Publication IPC-7351 may have alternate designs.

6. Solder mask tolerances between and around signal pads can vary based on board fabrication site.

EXAMPLE STENCIL DESIGN

NS0016A

SOP - 2.00 mm max height

SOP



SOLDER PASTE EXAMPLE
BASED ON 0.125 mm THICK STENCIL
SCALE:7X

4220735/A 12/2021

NOTES: (continued)

7. Laser cutting apertures with trapezoidal walls and rounded corners may offer better paste release. IPC-7525 may have alternate design recommendations.
8. Board assembly site may have different recommendations for stencil design.

D (R-PDSO-G16)

PLASTIC SMALL OUTLINE



4040047-6/M 06/11

- NOTES:
- A. All linear dimensions are in inches (millimeters).
 - B. This drawing is subject to change without notice.
 -  C. Body length does not include mold flash, protrusions, or gate burrs. Mold flash, protrusions, or gate burrs shall not exceed 0.006 (0,15) each side.
 -  D. Body width does not include interlead flash. Interlead flash shall not exceed 0.017 (0,43) each side.
 - E. Reference JEDEC MS-012 variation AC.

D (R-PDSO-G16)

PLASTIC SMALL OUTLINE



- NOTES:
- All linear dimensions are in millimeters.
 - This drawing is subject to change without notice.
 - Publication IPC-7351 is recommended for alternate designs.
 - Laser cutting apertures with trapezoidal walls and also rounding corners will offer better paste release. Customers should contact their board assembly site for stencil design recommendations. Refer to IPC-7525 for other stencil recommendations.
 - Customers should contact their board fabrication site for solder mask tolerances between and around signal pads.

MECHANICAL DATA

NS (R-PDSO-G**)

PLASTIC SMALL-OUTLINE PACKAGE

14-PINS SHOWN



- NOTES:
- A. All linear dimensions are in millimeters.
 - B. This drawing is subject to change without notice.
 - C. Body dimensions do not include mold flash or protrusion, not to exceed 0,15.

N (R-PDIP-T**)

PLASTIC DUAL-IN-LINE PACKAGE

16 PINS SHOWN



- NOTES:
- A. All linear dimensions are in inches (millimeters).
 - B. This drawing is subject to change without notice.
 - C Falls within JEDEC MS-001, except 18 and 20 pin minimum body length (Dim A).
 - D The 20 pin end lead shoulder width is a vendor option, either half or full width.

4040049/E 12/2002

IMPORTANT NOTICE AND DISCLAIMER

TI PROVIDES TECHNICAL AND RELIABILITY DATA (INCLUDING DATA SHEETS), DESIGN RESOURCES (INCLUDING REFERENCE DESIGNS), APPLICATION OR OTHER DESIGN ADVICE, WEB TOOLS, SAFETY INFORMATION, AND OTHER RESOURCES "AS IS" AND WITH ALL FAULTS, AND DISCLAIMS ALL WARRANTIES, EXPRESS AND IMPLIED, INCLUDING WITHOUT LIMITATION ANY IMPLIED WARRANTIES OF MERCHANTABILITY, FITNESS FOR A PARTICULAR PURPOSE OR NON-INFRINGEMENT OF THIRD PARTY INTELLECTUAL PROPERTY RIGHTS.

These resources are intended for skilled developers designing with TI products. You are solely responsible for (1) selecting the appropriate TI products for your application, (2) designing, validating and testing your application, and (3) ensuring your application meets applicable standards, and any other safety, security, regulatory or other requirements.

These resources are subject to change without notice. TI grants you permission to use these resources only for development of an application that uses the TI products described in the resource. Other reproduction and display of these resources is prohibited. No license is granted to any other TI intellectual property right or to any third party intellectual property right. TI disclaims responsibility for, and you will fully indemnify TI and its representatives against, any claims, damages, costs, losses, and liabilities arising out of your use of these resources.

TI's products are provided subject to [TI's Terms of Sale](#) or other applicable terms available either on [ti.com](https://www.ti.com) or provided in conjunction with such TI products. TI's provision of these resources does not expand or otherwise alter TI's applicable warranties or warranty disclaimers for TI products.

TI objects to and rejects any additional or different terms you may have proposed.

Mailing Address: Texas Instruments, Post Office Box 655303, Dallas, Texas 75265
Copyright © 2024, Texas Instruments Incorporated

Looking for pricing, stock, or lifecycle information?

Click below to explore more details on WIN SOURCE:

 [View SN65175D on WIN SOURCE](#)

 [Texas Instruments](#) Information

Optimize Your Supply Chain with WIN SOURCE Solutions

-  Global Sourcing Solution
-  Obsolete Management
-  Cost Control Management
-  Shortage Management
-  Alternative Solution
-  Excess Inventory Management