

PROTECTION PRODUCTS

Description

The SMS series of TVS arrays are designed to protect sensitive electronics from damage or latch-up due to ESD and other voltage-induced transient events. Each device will protect up to five lines. They are available with operating voltages of 5V, 12V, 15V and 24V. They are unidirectional devices and may be used on lines where the signal polarities are above ground.

TVS diodes are solid-state devices designed specifically for transient suppression. They feature large cross-sectional area junctions for conducting high transient currents. They offer desirable characteristics for board level protection including fast response time, low operating and clamping voltage and no device degradation.

The SMS series devices may be used to meet the immunity requirements of IEC 61000-4-2, level 4. The low cost SOT23-6L package makes them ideal for use in portable electronics such as cell phones, PDA's, and notebook computers.

Features

- ◆ Transient protection for data lines to **IEC 61000-4-2 (ESD) $\pm 15\text{kV}$ (air), $\pm 8\text{kV}$ (contact)**
- ◆ **IEC 61000-4-4 (EFT) 40A (5/50ns)**
- ◆ **IEC 61000-4-5 (Lightning) 24A (8/20 μ s)**
- ◆ Small package for use in portable electronics
- ◆ Protects five I/O lines
- ◆ Working voltages: 5V, 12V, 15V and 24V
- ◆ Low leakage current
- ◆ Low operating and clamping voltages
- ◆ Solid-state silicon avalanche technology

Mechanical Characteristics

- ◆ EIAJ SOT23-6L package
- ◆ Molding compound flammability rating: UL 94V-0
- ◆ Marking : Marking Code
- ◆ Packaging : Tape and Reel per EIA 481

Applications

- ◆ Cell phone Handsets and Accessories
- ◆ Microprocessor Based Equipment
- ◆ Personal Digital Assistants (PDA's)
- ◆ Notebooks, Desktops, and Servers
- ◆ Portable Instrumentation
- ◆ Set Top Box
- ◆ Peripherals
- ◆ MP3 Players
- ◆ Cordless Phones

Circuit Diagram

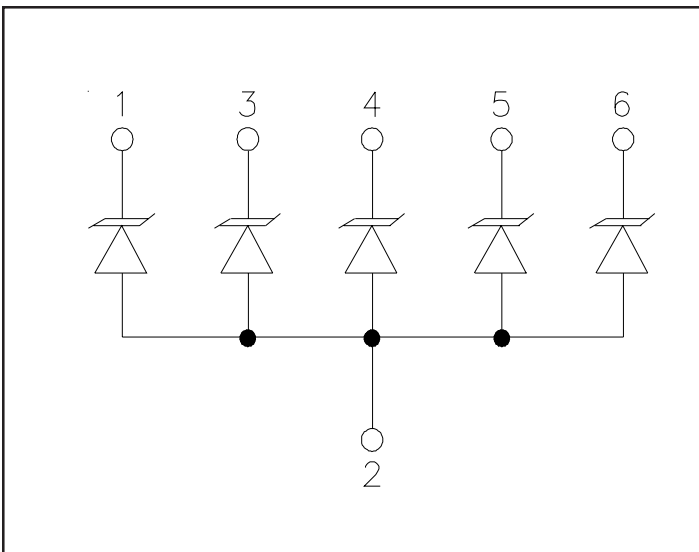

Schematic & PIN Configuration

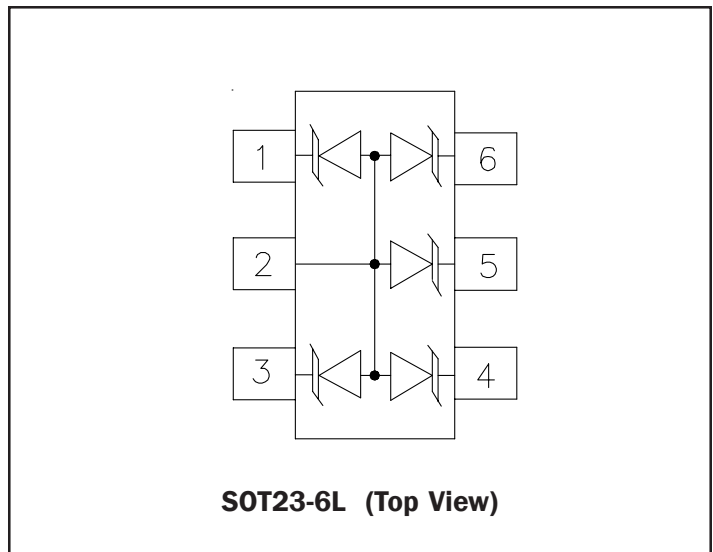

PROTECTION PRODUCTS
Absolute Maximum Rating

Rating	Symbol	Value	Units
Peak Pulse Power ($t_p = 8/20\mu s$)	P_{pk}	300	Watts
Peak Forward Voltage ($I_F = 1A, t_p = 8/20\mu s$)	V_{FP}	1.5	V
Lead Soldering Temperature	T_L	260 (10 sec.)	°C
Operating Temperature	T_J	-55 to +125	°C
Storage Temperature	T_{STG}	-55 to +150	°C

Electrical Characteristics

SMS05C						
Parameter	Symbol	Conditions	Minimum	Typical	Maximum	Units
Reverse Stand-Off Voltage	V_{RWM}				5	V
Reverse Breakdown Voltage	V_{BR}	$I_t = 1mA$	6			V
Reverse Leakage Current	I_R	$V_{RWM} = 5V, T = 25^\circ C$			20	μA
Clamping Voltage	V_C	$I_{PP} = 5A, t_p = 8/20\mu s$			9.8	V
Clamping Voltage	V_C	$I_{PP} = 24A, t_p = 8/20\mu s$			14.5	V
Peak Pulse Current	I_{PP}	$t_p = 8/20\mu s$			24	A
Junction Capacitance	C_J	Between I/O Pins and Ground $V_R = 0V, f = 1MHz$		325	400	pF

SMS12C						
Parameter	Symbol	Conditions	Minimum	Typical	Maximum	Units
Reverse Stand-Off Voltage	V_{RWM}				12	V
Reverse Breakdown Voltage	V_{BR}	$I_t = 1mA$	13.3			V
Reverse Leakage Current	I_R	$V_{RWM} = 12V, T = 25^\circ C$			1	μA
Clamping Voltage	V_C	$I_{PP} = 5A, t_p = 8/20\mu s$			19	V
Clamping Voltage	V_C	$I_{PP} = 15A, t_p = 8/20\mu s$			23	V
Peak Pulse Current	I_{PP}	$t_p = 8/20\mu s$			15	A
Junction Capacitance	C_J	Between I/O Pins and Ground $V_R = 0V, f = 1MHz$		135	150	pF

PROTECTION PRODUCTS

Electrical Characteristics (Continued)

SMS15C						
Parameter	Symbol	Conditions	Minimum	Typical	Maximum	Units
Reverse Stand-Off Voltage	V_{RWM}				15	V
Reverse Breakdown Voltage	V_{BR}	$I_t = 1mA$	16.7			V
Reverse Leakage Current	I_R	$V_{RWM} = 15V, T=25^\circ C$			1	μA
Clamping Voltage	V_C	$I_{PP} = 5A, t_p = 8/20\mu s$			24	V
Clamping Voltage	V_C	$I_{PP} = 12A, t_p = 8/20\mu s$			29	V
Peak Pulse Current	I_{PP}	$t_p = 8/20\mu s$			12	A
Junction Capacitance	C_J	Between I/O Pins and Ground $V_R = 0V, f = 1MHz$		100	125	pF

SMS24C						
Parameter	Symbol	Conditions	Minimum	Typical	Maximum	Units
Reverse Stand-Off Voltage	V_{RWM}				24	V
Reverse Breakdown Voltage	V_{BR}	$I_t = 1mA$	26.7			V
Reverse Leakage Current	I_R	$V_{RWM} = 24V, T=25^\circ C$			1	μA
Clamping Voltage	V_C	$I_{PP} = 5A, t_p = 8/20\mu s$			40	V
Clamping Voltage	V_C	$I_{PP} = 8A, t_p = 8/20\mu s$			44	V
Peak Pulse Current	I_{PP}	$t_p = 8/20\mu s$			8	A
Junction Capacitance	C_J	Between I/O Pins and Ground $V_R = 0V, f = 1MHz$		60	75	pF

PROTECTION PRODUCTS

Typical Characteristics

Non-Repetitive Peak Pulse Power vs. Pulse Time

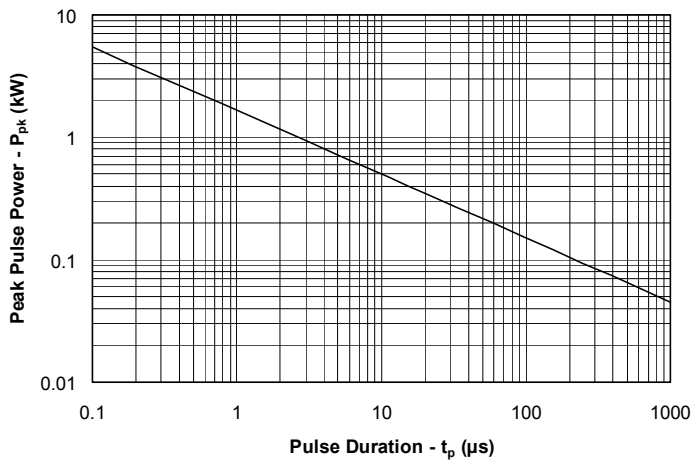

Power Derating Curve

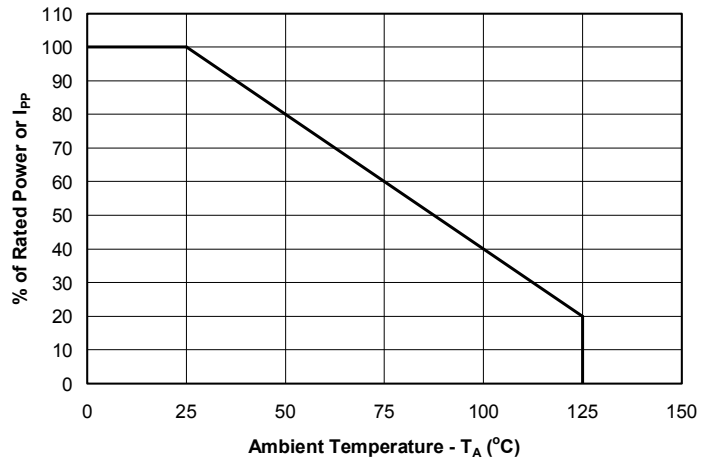

Pulse Waveform

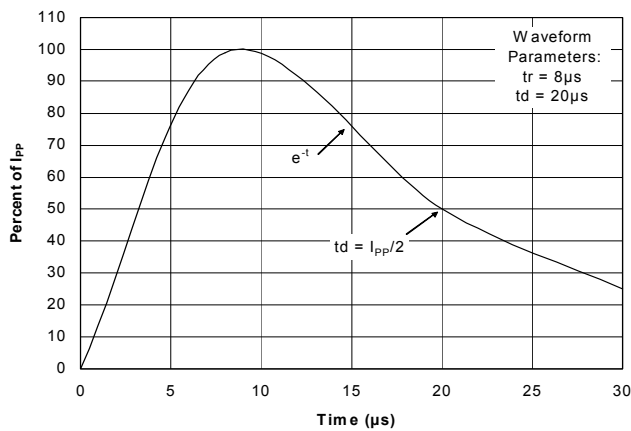

Clamping Voltage vs. Peak Pulse Current

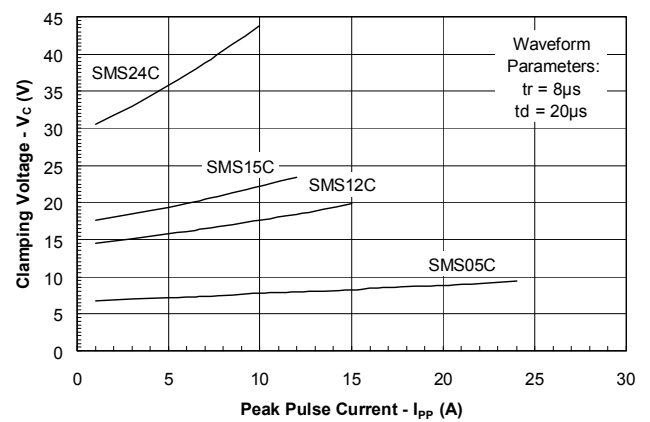

Forward Voltage vs. Forward Current

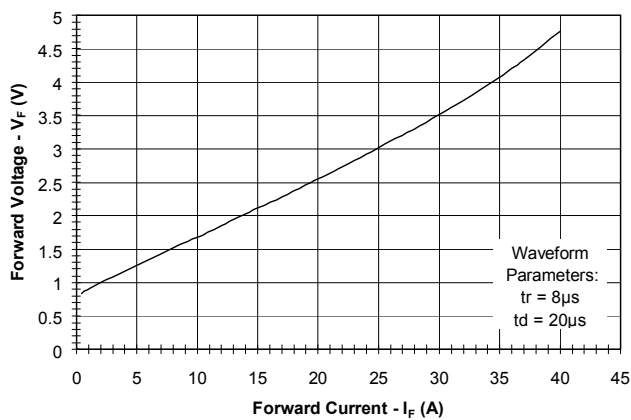

PROTECTION PRODUCTS

Applications Information

Device Connection for Protection of Five Data Lines

The SMSxxC is designed to protect up to five unidirectional data lines. The device is connected as follows:

1. Unidirectional protection of five I/O lines is achieved by connecting pins 1, 3, 4, 5 and 6 to the data lines. Pin 2 is connected to ground. The ground connection should be made directly to the ground plane for best results. The path length is kept as short as possible to reduce the effects of parasitic inductance in the board traces.

Circuit Board Layout Recommendations for Suppression of ESD.

Good circuit board layout is critical for the suppression of ESD induced transients. The following guidelines are recommended:

- Place the SMSxxC near the input terminals or connectors to restrict transient coupling.
- Minimize the path length between the SMSxxC and the protected line.
- Minimize all conductive loops including power and ground loops.
- The ESD transient return path to ground should be kept as short as possible.
- Never run critical signals near board edges.
- Use ground planes whenever possible.

Matte Tin Lead Finish

Matte tin has become the industry standard lead-free replacement for SnPb lead finishes. A matte tin finish is composed of 100% tin solder with large grains. Since the solder volume on the leads is small compared to the solder paste volume that is placed on the land pattern of the PCB, the reflow profile will be determined by the requirements of the solder paste. Therefore, these devices are compatible with both lead-free and SnPb assembly techniques. In addition, unlike other lead-free compositions, matte tin does not have any added alloys that can cause degradation of the solder joint.

SMSxxC Circuit Diagram

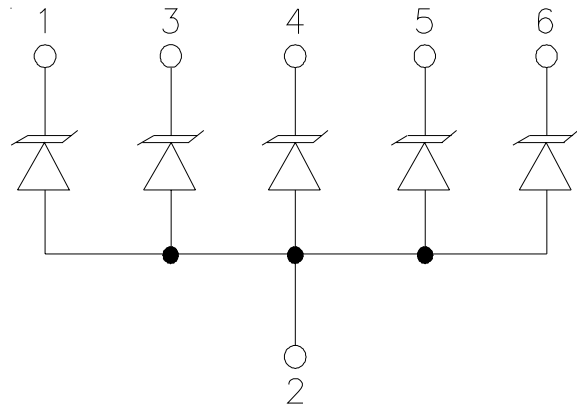

Protection of Five Unidirectional Lines

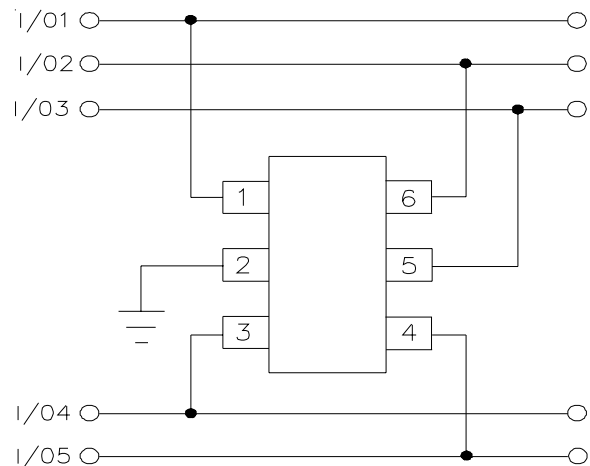

PROTECTION PRODUCTS

Outline Drawing -SOT23 6L

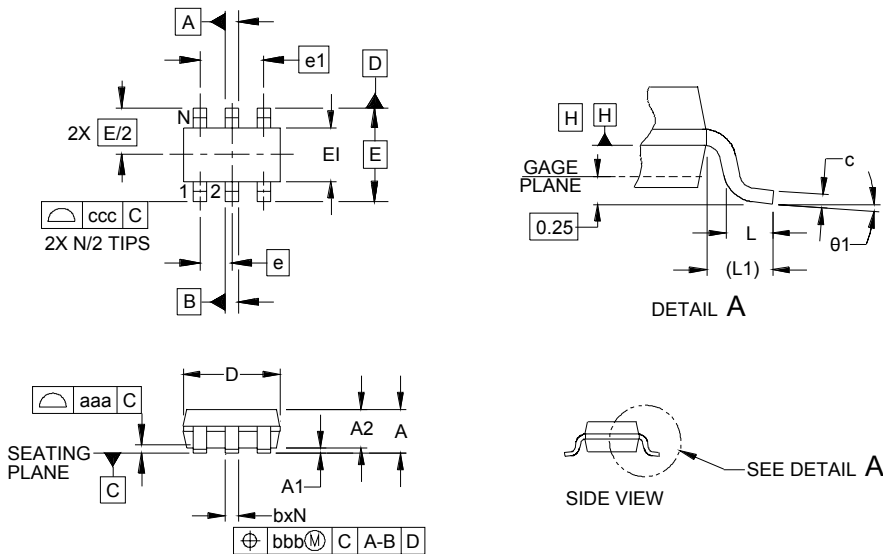

DIM	INCHES			MILLIMETERS		
	MIN	NOM	MAX	MIN	NOM	MAX
A	.035	-	.057	0.90	-	1.45
A1	.000	-	.006	0.00	-	0.15
A2	.035	.045	.051	.90	1.15	1.30
b	.010	-	.020	0.25	-	0.50
c	.003	-	.009	0.08	-	0.22
D	.110	.114	.118	2.80	2.90	3.00
E1	.060	.063	.069	1.50	1.60	1.75
E	.110 BSC			2.80 BSC		
e	.037 BSC			0.95 BSC		
e1	.075 BSC			1.90 BSC		
L	.012	.018	.024	0.30	0.45	0.60
L1	(0.24)			(0.60)		
N	6			6		
theta1	0°	-	10°	0°	-	10°
aaa	.004			0.10		
bbb	.008			0.20		
ccc	.008			0.20		

NOTES:

1. CONTROLLING DIMENSIONS ARE IN MILLIMETERS (ANGLES IN DEGREES).
2. DATUMS **-A-** AND **-B-** TO BE DETERMINED AT DATUM PLANE **-H-**
3. DIMENSIONS "E1" AND "D" DO NOT INCLUDE MOLD FLASH, PROTRUSIONS OR GATE BURRS.

Land Pattern -SOT23 6L

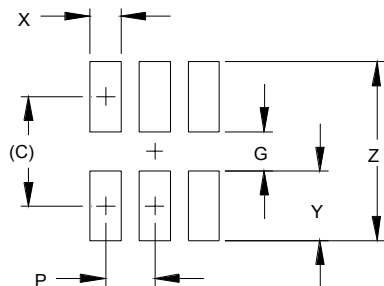

DIM	DIMENSIONS	
	INCHES	MILLIMETERS
C	(.098)	(2.50)
G	.055	1.40
P	.037	0.95
X	.024	0.60
Y	.043	1.10
Z	.141	3.60

NOTES:

1. THIS LAND PATTERN IS FOR REFERENCE PURPOSES ONLY. CONSULT YOUR MANUFACTURING GROUP TO ENSURE YOUR COMPANY'S MANUFACTURING GUIDELINES ARE MET.

PROTECTION PRODUCTS**Marking Codes**

Part Number	Marking Code
SMS05C	C05
SMS12C	C12
SMS15C	C15
SMS24C	C24

Note:

Pin 1 Identified with a dot.

Ordering Information

Part Number	Lead Finish	Qty per Reel	Reel Size
SMS05C.TC	SnPb	3,000	7 Inch
SMS12C.TC	SnPb	3,000	7 Inch
SMS15C.TC	SnPb	3,000	7 Inch
SMS24C.TC	SnPb	3,000	7 Inch
SMS05C.TCT	Pb Free	3,000	7 Inch
SMS12C.TCT	Pb Free	3,000	7 Inch
SMS15C.TCT	Pb Free	3,000	7 Inch
SMS24C.TCT	Pb Free	3,000	7 Inch

Note:

(1) No suffix indicates tube pack.

Looking for pricing, stock, or lifecycle information?

Click below to explore more details on WIN SOURCE:

 [View SMS05C.TCT on WIN SOURCE](#)

 [Semtech Corporation](#) Information

Optimize Your Supply Chain with WIN SOURCE Solutions

-  Global Sourcing Solution
-  Obsolete Management
-  Cost Control Management
-  Shortage Management
-  Alternative Solution
-  Excess Inventory Management