



**THE DATASHEET OF  
74F219PC**



## 74F219 64-Bit Random Access Memory with 3-STATE Outputs

### General Description

The 74F219 is a high-speed 64-bit RAM organized as a 16-word by 4-bit array. Address inputs are buffered to minimize loading and are fully decoded on-chip. The outputs are 3-STATE and are in the high-impedance state whenever the Chip Select ( $\overline{CS}$ ) input is HIGH. The outputs are active only in the Read mode. This device is similar to the 74F189 but features non-inverting, rather than inverting, data outputs.

### Features

- 3-STATE outputs for data bus applications
- Buffered inputs minimize loading
- Address decoding on-chip
- Diode clamped inputs minimize ringing
- Available in SOIC (300 mil only)

### Ordering Code:

Order Number	Package Number	Package Description
74F219SC	M16B	16-Lead Small Outline Intergrated Circuit (SOIC), JEDEC MS-013, 0.300" Wide
74F219PC	N16E	16-Lead Plastic Dual-In-Line Package (PDIP), JEDEC MS-001, 0.300" Wide

### Logic Symbol

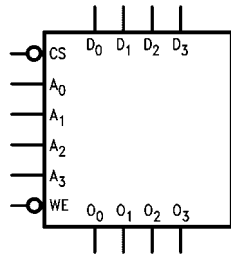

### Connection Diagram

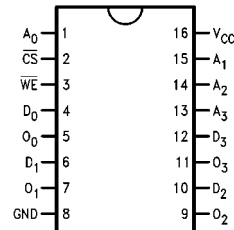

## Unit Loading/Fan Out

Pin Names	Description	U.L. HIGH/LOW	Input $I_{IH}/I_{IL}$ Output $I_{OH}/I_{OL}$
$A_0$ - $A_3$	Address Inputs	1.0/1.0	20 $\mu$ A/-0.6 mA
$\overline{CS}$	Chip Select Input (Active LOW)	1.0/2.0	20 $\mu$ A/-1.2 mA
$\overline{WE}$	Write Enable Input (Active LOW)	1.0/1.0	20 $\mu$ A/-0.6 mA
$D_0$ - $D_3$	Data Inputs	1.0/1.0	20 $\mu$ A/-0.6 mA
$O_0$ - $O_3$	3-STATE Data Outputs	150/40 (33.3)	-3 mA/24 mA (20 mA)

## Function Table

Inputs		Operation	Condition of Outputs
$\overline{CS}$	$\overline{WE}$		
L	L	Write	High Impedance
L	H	Read	True Stored Data
H	X	Inhibit	High Impedance

H = HIGH Voltage Level  
L = LOW Voltage Level  
X = Immaterial

## Block Diagram

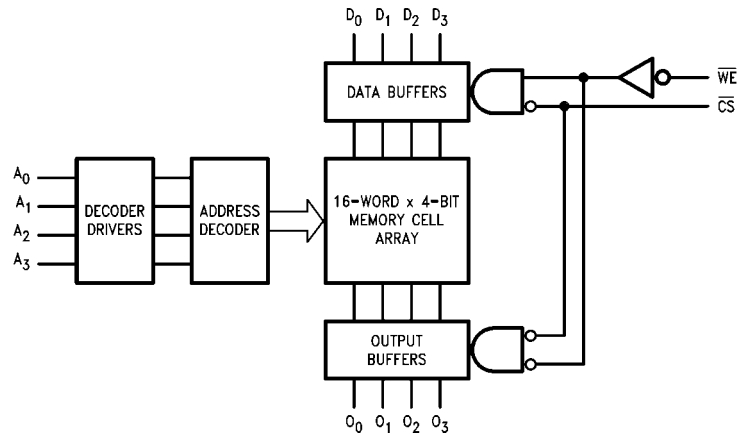

**Absolute Maximum Ratings**(Note 1)

Storage Temperature	-65°C to +150°C
Ambient Temperature under Bias	-55°C to +125°C
Junction Temperature under Bias	-55°C to +150°C
V <sub>CC</sub> Pin Potential to Ground Pin	-0.5V to +7.0V
Input Voltage (Note 2)	-0.5V to +7.0V
Input Current (Note 2)	-30 mA to +5.0 mA
Voltage Applied to Output in HIGH State (with V <sub>CC</sub> = 0V)	
Standard Output	-0.5V to V <sub>CC</sub>
3-STATE Output	-0.5V to +5.5V
Current Applied to Output in LOW State (Max)	twice the rated I <sub>OL</sub> (mA)

**Recommended Operating Conditions**

Free Air Ambient Temperature	0°C to +70°C
Supply Voltage	+4.5V to +5.5V

**Note 1:** Absolute maximum ratings are values beyond which the device may be damaged or have its useful life impaired. Functional operation under these conditions is not implied.

**Note 2:** Either voltage limit or current limit is sufficient to protect inputs.

**DC Electrical Characteristics**

Symbol	Parameter	Min	Typ	Max	Units	V <sub>CC</sub>	Conditions
V <sub>IH</sub>	Input HIGH Voltage	2.0			V		Recognized as a HIGH Signal
V <sub>IL</sub>	Input LOW Voltage			0.8	V		Recognized as a LOW Signal
V <sub>CD</sub>	Input Clamp Diode Voltage			-1.2	V	Min	I <sub>IN</sub> = -18 mA
V <sub>OH</sub>	Output HIGH Voltage	10% V <sub>CC</sub> 10% V <sub>CC</sub> 5% V <sub>CC</sub> 5% V <sub>CC</sub>	2.5 2.4 2.7 2.7		V	Min	I <sub>OH</sub> = -1 mA I <sub>OH</sub> = -3 mA I <sub>OH</sub> = -1 mA I <sub>OH</sub> = -3 mA
V <sub>OL</sub>	Output LOW Voltage	10% V <sub>CC</sub>		0.5	V	Min	I <sub>OL</sub> = 24 mA
I <sub>IH</sub>	Input HIGH Current			5.0	μA	Max	V <sub>IN</sub> = 2.7V
I <sub>BVI</sub>	Input HIGH Current Breakdown Test			7.0	μA	Max	V <sub>IN</sub> = 7.0V
I <sub>CEx</sub>	Output HIGH Leakage Current			50	μA	Max	V <sub>OUT</sub> = V <sub>CC</sub>
V <sub>ID</sub>	Input Leakage Test	4.75			V	0.0	I <sub>ID</sub> = 1.9 μA All Other Pins Grounded
I <sub>OD</sub>	Output Leakage Circuit Current			3.75	μA	0.0	V <sub>IOD</sub> = 150 mV All Other Pins Grounded
I <sub>IL</sub>	Input LOW Current			-0.6 -1.2	mA	Max	V <sub>IN</sub> = 0.5V (A <sub>n</sub> , $\overline{WE}$ , D <sub>n</sub> ) V <sub>IN</sub> = 0.5V (CS)
I <sub>OZH</sub>	Output Leakage Current			50	μA	Max	V <sub>OUT</sub> = 2.7V
I <sub>OZL</sub>	Output Leakage Current			-50	μA	Max	V <sub>OUT</sub> = 0.5V
I <sub>OS</sub>	Output Short-Circuit Current	-60		-150	mA	Max	V <sub>OUT</sub> = 0V
I <sub>ZZ</sub>	Bus Drainage Test			500	μA	0.0V	V <sub>OUT</sub> = 5.25V
I <sub>CC</sub>	Power Supply Current		37	55	mA	Max	

AC Electrical Characteristics									
Symbol	Parameter	$T_A = +25^\circ\text{C}$ $V_{CC} = +5.0\text{V}$ $C_L = 50\text{ pF}$			$T_A = -55^\circ\text{C to } +125^\circ\text{C}$ $V_{CC} = +5.0\text{V}$ $C_L = 50\text{ pF}$		$T_A = 0^\circ\text{C to } +70^\circ\text{C}$ $V_{CC} = +5.0\text{V}$ $C_L = 50\text{ pF}$		Units
		Min	Typ	Max	Min	Max	Min	Max	
$t_{PLH}$	Access Time, HIGH or LOW	10.0	18.5	26.0	9.0	32.0	10.0	27.0	ns
$t_{PHL}$	$A_n$ to $O_n$	8.0	13.5	19.0	8.0	23.0	8.0	20.0	
$t_{PZH}$	Access Time, HIGH or LOW	3.5	6.0	8.5	3.5	10.5	3.5	9.5	ns
$t_{PZL}$	$\overline{CS}$ to $O_n$	5.0	9.0	13.0	5.0	15.0	5.0	14.0	
$t_{PHZ}$	Disable Time, HIGH or LOW	2.0	4.0	6.0	2.0	8.0	2.0	7.0	ns
$t_{PLZ}$	$\overline{CS}$ to $O_n$	3.0	5.5	8.0	2.5	10.0	3.0	9.0	
$t_{PZH}$	Write Recovery Time	6.5	20.0	28.0	6.5	37.5	6.5	29.0	ns
$t_{PZL}$	HIGH or LOW, $\overline{WE}$ to $O_n$	6.5	11.0	15.5	6.5	17.5	6.5	16.5	
$t_{PHZ}$	Disable Time, HIGH or LOW	4.0	7.0	10.0	3.5	12.0	4.0	11.0	ns
$t_{PLZ}$	$\overline{WE}$ to $O_n$	5.0	9.0	13.0	5.0	15.0	5.0	14.0	

  

AC Operating Requirements									
Symbol	Parameter	$T_A = +25^\circ\text{C}$ $V_{CC} = +5.0\text{V}$		$T_A = -55^\circ\text{C to } +125^\circ\text{C}$ $V_{CC} = +5.0\text{V}$		$T_A = 0^\circ\text{C to } +70^\circ\text{C}$ $V_{CC} = +5.0\text{V}$		Units	
		Min	Max	Min	Max	Min	Max		
$t_S(H)$	Setup Time, HIGH or LOW	0		0		0		ns	
$t_S(L)$	$A_n$ to $\overline{WE}$	0		0		0			
$t_H(H)$	Hold Time, HIGH or LOW	2.0		2.0		2.0		ns	
$t_H(L)$	$A_n$ to $\overline{WE}$	2.0		2.0		2.0			
$t_S(H)$	Setup Time, HIGH or LOW	10.0		11.0		10.0		ns	
$t_S(L)$	$D_n$ to $\overline{WE}$	10.0		11.0		10.0			
$t_H(H)$	Hold Time, HIGH or LOW	0		2.0		0		ns	
$t_H(L)$	$D_n$ to $\overline{WE}$	0		2.0		0			
$t_S(L)$	Setup Time, LOW	0		0		0		ns	
$t_H(L)$	Hold Time, LOW	6.0		7.5		6.0			
$t_W(L)$	$\overline{WE}$ Pulse Width, LOW	6.0		15.0		6.0		ns	

**Physical Dimensions** inches (millimeters) unless otherwise noted

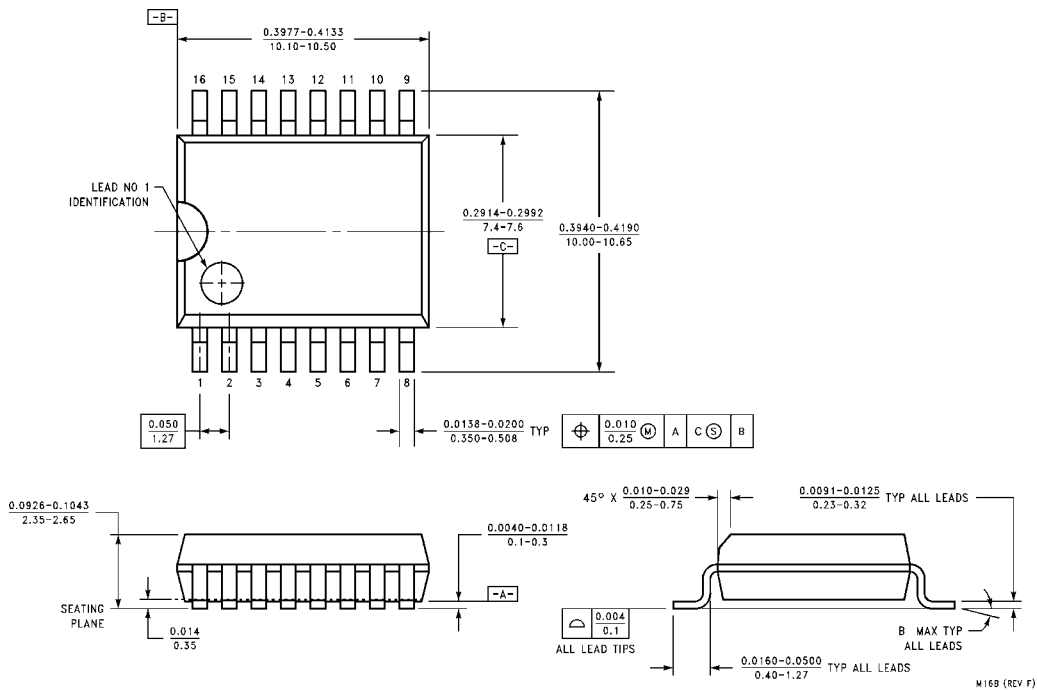

**16-Lead Small Outline Integrated Circuit (SOIC), JEDEC MS-013, 0.300" Wide  
Package Number M16B**

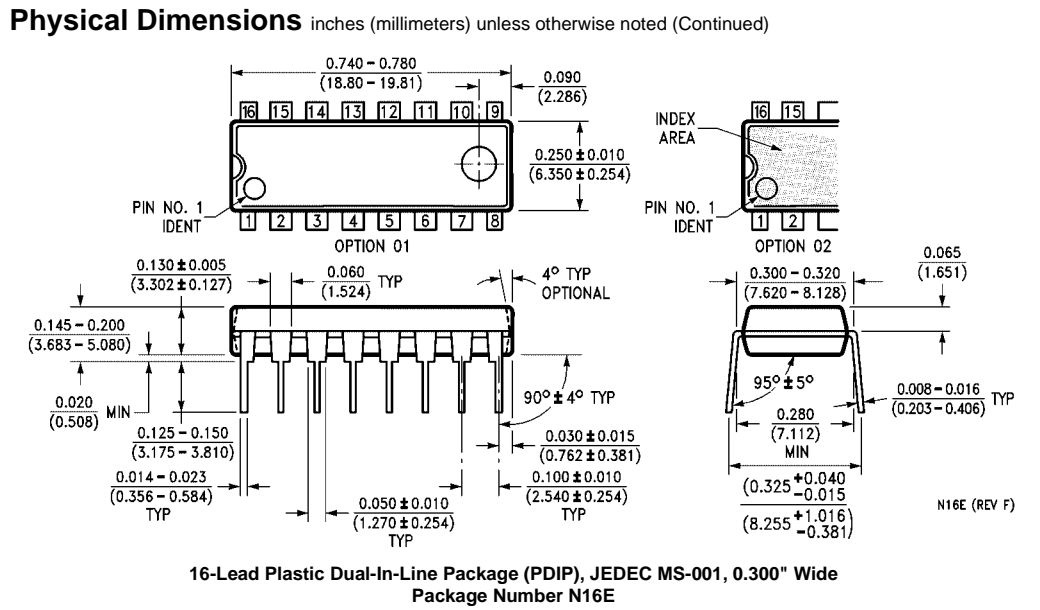

Fairchild does not assume any responsibility for use of any circuitry described, no circuit patent licenses are implied and Fairchild reserves the right at any time without notice to change said circuitry and specifications.

**LIFE SUPPORT POLICY**



FAIRCHILD'S PRODUCTS ARE NOT AUTHORIZED FOR USE AS CRITICAL COMPONENTS IN LIFE SUPPORT DEVICES OR SYSTEMS WITHOUT THE EXPRESS WRITTEN APPROVAL OF THE PRESIDENT OF FAIRCHILD SEMICONDUCTOR CORPORATION. As used herein:

1. Life support devices or systems are devices or systems which, (a) are intended for surgical implant into the body, or (b) support or sustain life, and (c) whose failure to perform when properly used in accordance with instructions for use provided in the labeling, can be reasonably expected to result in a significant injury to the user.
2. A critical component in any component of a life support device or system whose failure to perform can be reasonably expected to cause the failure of the life support device or system, or to affect its safety or effectiveness.

[www.fairchildsemi.com](http://www.fairchildsemi.com)

## Looking for pricing, stock, or lifecycle information?

Click below to explore more details on WIN SOURCE:

-  [View 74F219PC](#) on WIN SOURCE
-  [Fairchild/ON Semiconductor](#) Information

## Optimize Your Supply Chain with WIN SOURCE Solutions

-  Global Sourcing Solution
-  Obsolete Management
-  Cost Control Management
-  Shortage Management
-  Alternative Solution
-  Excess Inventory Management