



# THE DATASHEET OF SLVU2.8.TCT



### PROTECTION PRODUCTS

#### Description

The SLV series of transient voltage suppressors are designed to protect low voltage, state-of-the-art CMOS semiconductors from transients caused by electrostatic discharge (ESD), cable discharge events (CDE), lightning and other induced voltage surges.

The devices are constructed using Semtech's proprietary EPD process technology. The EPD process provides low standoff voltages with significant reductions in leakage currents and capacitance over silicon-avalanche diode processes. The SLVU2.8 features an integrated low capacitance compensation diode that allows the device to be configured to protect one unidirectional line or, when paired with a second SLVU2.8, two high-speed line pairs. The low capacitance design of the SLVU2.8 means signal integrity is preserved in high-speed applications such as 10/100 Ethernet.

The SLVU2.8 is in an SOT23 package and has a low 2.8 volt working voltage. It is specifically designed to protect low voltage components such as Ethernet transceivers, laser diodes, ASICs, and high-speed RAM. The low clamping voltage of the SLVU2.8 minimizes the stress on the protected IC.

The SLV series TVS diodes will exceed the surge requirements of IEC 61000-4-2, Level 4.

#### Features

- ◆ 400 Watts peak pulse power ( $t_p = 8/20\mu s$ )
- ◆ Transient protection for high speed data lines to **IEC 61000-4-2 (ESD)  $\pm 15kV$  (air),  $\pm 8kV$  (contact)**  
**IEC 61000-4-4 (EFT) 40A (5/50ns)**  
**IEC 61000-4-5 (Lightning) 24A (8/20 $\mu s$ )**
- ◆ One device protects one unidirectional line
- ◆ Two devices protect two high-speed line pairs
- ◆ Low capacitance
- ◆ Low leakage current
- ◆ Low operating and clamping voltages
- ◆ Solid-state EPD TVS process technology

#### Mechanical Characteristics

- ◆ JEDEC SOT23 package
- ◆ Molding compound flammability rating: UL 94V-0
- ◆ Marking : U2.8
- ◆ Packaging : Tape and Reel per EIA 481

#### Applications

- ◆ 10/100 Ethernet
- ◆ WAN/LAN Equipment
- ◆ Switching Systems
- ◆ Desktops, Servers, Notebooks & Handhelds
- ◆ Laser Diode Protection
- ◆ Base Stations

#### Circuit Diagram

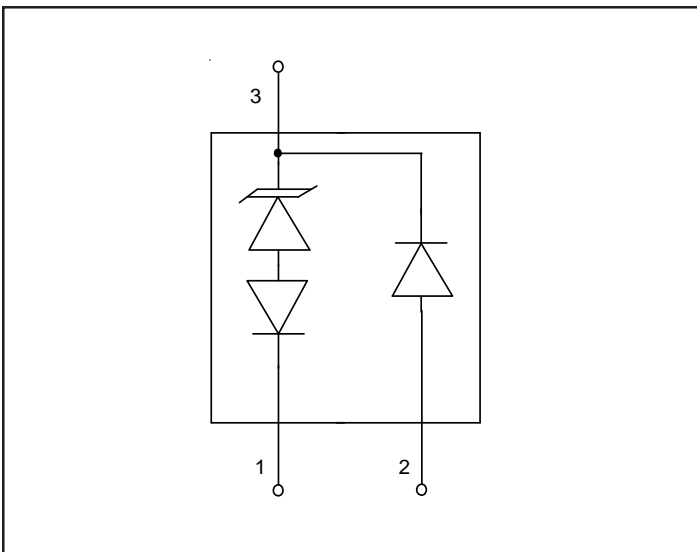

#### Schematic & PIN Configuration

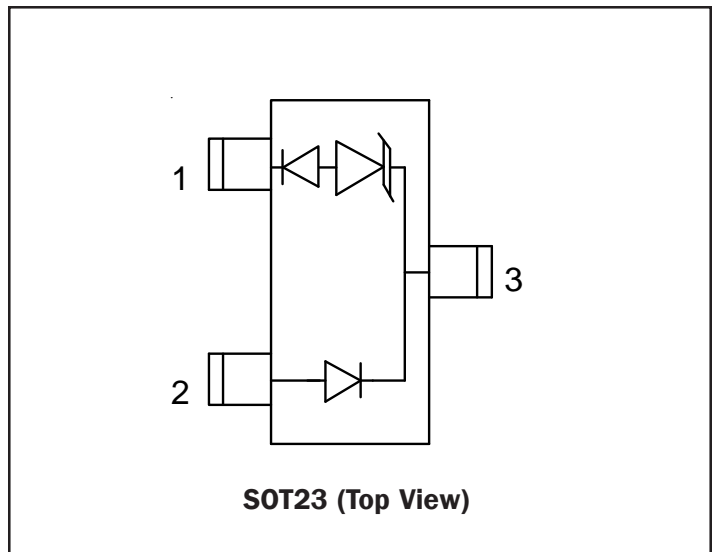

**PROTECTION PRODUCTS**
**Absolute Maximum Rating**

Rating	Symbol	Value	Units
Peak Pulse Power (tp = 8/20μs)	$P_{pk}$	400	Watts
Peak Pulse Current (tp = 8/20μs)	$I_{pp}$	24	A
Lead Soldering Temperature	$T_L$	260 (10 seconds)	°C
Operating Temperature	$T_J$	-55 to +125	°C
Storage Temperature	$T_{STG}$	-55 to +150	°C

**Electrical Characteristics**

<b>SLVU2.8</b>						
Parameter	Symbol	Conditions	Minimum	Typical	Maximum	Units
Reverse Stand-Off Voltage	$V_{RWM}$	Pin 3 to 1 or Pin 2 to 1			2.8	V
Punch-Through Voltage	$V_{PT}$	$I_{PT} = 2\mu A$ , Pin 3 to 1	3.0			V
Snap-Back Voltage	$V_{SB}$	$I_{SB} = 50mA$ , Pin 3 to 1	2.8			V
Reverse Leakage Current	$I_R$	$V_{RWM} = 2.8V$ , $T=25^\circ C$ Pin 3 to 1 or Pin 2 to 1			1	μA
Clamping Voltage	$V_C$	$I_{pp} = 2A$ , $t_d = 8/20\mu s$ Pin 3 to 1			3.9	V
Clamping Voltage	$V_C$	$I_{pp} = 5A$ , $t_d = 8/20\mu s$ Pin 3 to 1			7	V
Clamping Voltage	$V_C$	$I_{pp} = 24A$ , $t_d = 8/20\mu s$ Pin 3 to 1			12.5	V
Clamping Voltage	$V_C$	$I_{pp} = 5A$ , $t_d = 8/20\mu s$ Pin 2 to 1			8.5	V
Clamping Voltage	$V_C$	$I_{pp} = 24A$ , $t_d = 8/20\mu s$ Pin 2 to 1			15	V
Junction Capacitance	$C_j$	Pin 3 to 1 and 2 (Pin 1 and 2 tied together) $V_R = 0V$ , $f = 1MHz$		70	100	pF
Junction Capacitance	$C_j$	Pin 2 to 1 (pin 3 N.C.) $V_R = 0V$ , $f = 1MHz$		5	10	pF
<b>Steering Diode Characteristics</b>						
Reverse Breakdown Voltage	$V_{BR}$	$I_T = 10\mu A$ , Pin 3 to 2	40			V
Reverse Leakage Current	$I_{RD}$	$V_{RWM} = 2.8V$ , $T=25^\circ C$ Pin 3 to 2			1	μA
Forward Voltage	$V_F$	$I_F = 1A$ , Pin 2 to 3			2	V

PROTECTION PRODUCTS

Typical Characteristics

Non-Repetitive Peak Pulse Power vs. Pulse Time

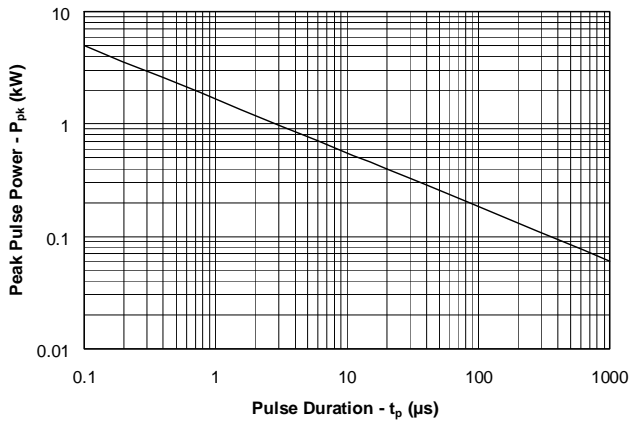

Power Derating Curve

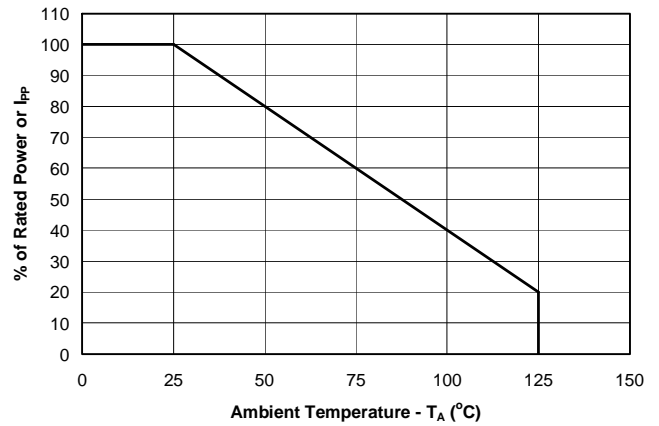

Pulse Waveform

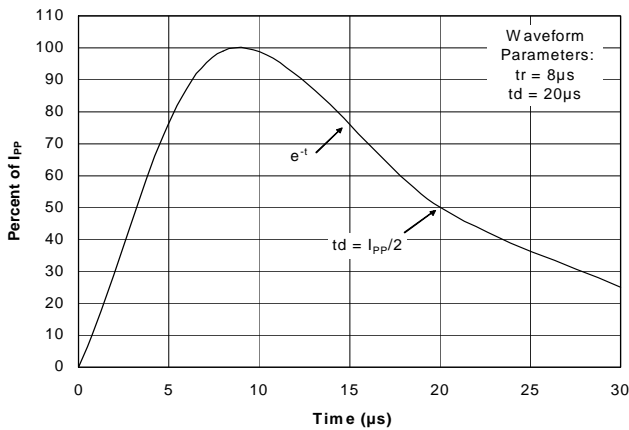

Clamping Voltage vs. Peak Pulse Current

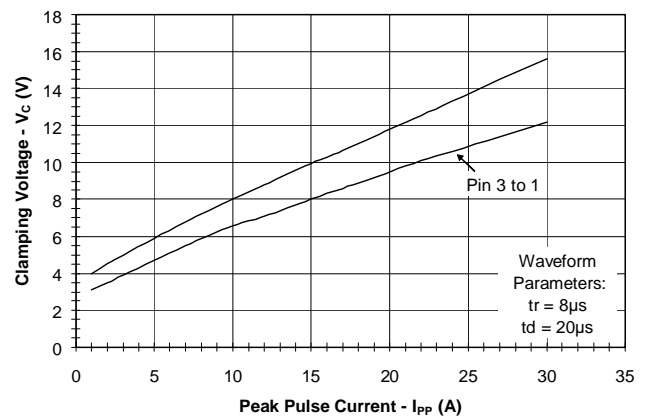

Forward Voltage vs. Forward Current

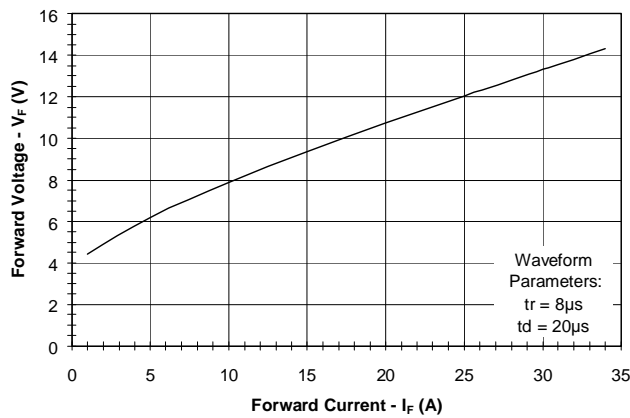

Normalized Capacitance vs. Reverse Voltage

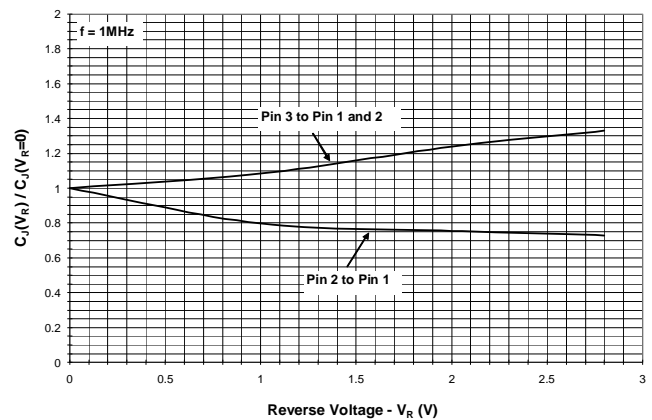

**Insertion Loss S21**



**PROTECTION PRODUCTS**

**Applications Information**

**Device Connection Options**

Electronic equipment is susceptible to transient disturbances from a variety of sources including: ESD to an open connector or interface, direct or nearby lightning strikes to cables and wires, and charged cables “hot plugged” into I/O ports. The SLVU2.8 is designed to protect sensitive components from damage and latch-up which may result from such transient events. The SLVU2.8 can be configured to protect either one unidirectional line or two (one line pair) high-speed data lines. The options for connecting the devices are as follows:

- 1. Protection of one unidirectional I/O line:** Protection of one data line is achieved by connecting pin 3 to the protected line, and pins 1 and 2 to ground. This connection option will allow the device to operate on lines with positive polarity signal transitions (during normal operation). In this configuration, the device adds a maximum loading capacitance of 100pF. During positive duration transients, the internal TVS diode will be reversed biased and will act in the avalanche mode, conducting the transient current from pin 3 to 1. The transient will be clamped at or below the rated clamping voltage of the device. For negative duration transients, the internal steering diode is forward biased, conducting the transient current from pin 2 to 3. The transient is clamped below the rated forward voltage drop of the diode.
- 2. Low capacitance protection of one differential line pair:** Protection of a high-speed differential line pair is achieved by connecting two devices in anti-parallel. Pin 1 of the first device is connected to line 1 and pin 2 is connected to line 2. Pin 2 of the second device is connected to line 1 and pin 1 is connected to line 2 as shown. Pin 3 must be left open on both devices. During negative duration transients, the first device will conduct from pin 2 to 1. The steering diode conducts in the forward direction while the TVS will avalanche and conduct in the reverse direction. During positive transients, the second device will conduct in the same manner. In this configuration, the total loading capacitance is the sum of the capacitance (between pins 1 and 2) of each device (typically <10pF) making this configuration suitable for high-speed interfaces such as 10/100 Ethernet (See application note SI98-02).

**SLVU2.8 Circuit Diagram**

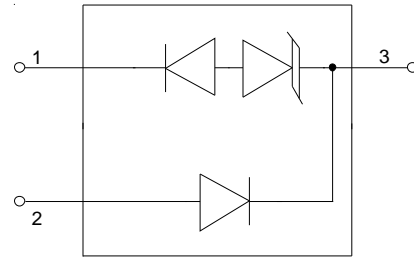

**Protection of one unidirectional line**

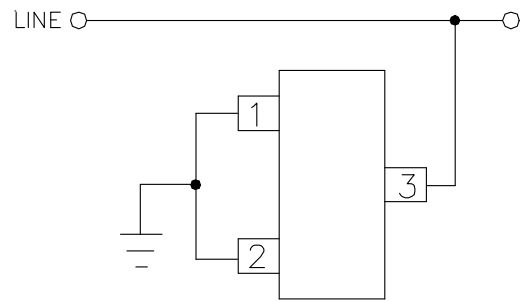

**Low capacitance protection of one high-speed line pair**

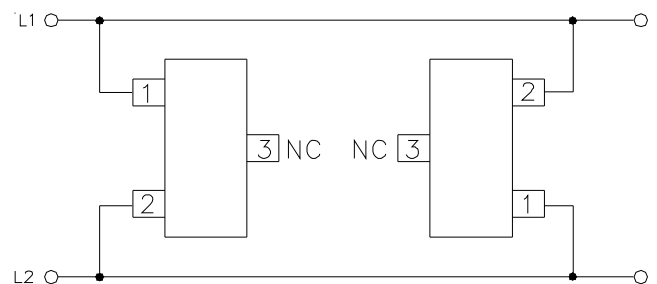

**EPD TVS Characteristics**

The SLVU2.8 is constructed using Semtech’s proprietary EPD technology. The structure of the EPD TVS is vastly different from the traditional pn-junction devices. At voltages below 5V, high leakage current and junction capacitance render conventional avalanche technology impractical for most applications. However, by utilizing the EPD technology, the SLVU2.8 can effectively operate at 2.8V while maintaining excellent electrical characteristics.

The EPD TVS employs a complex nppn structure in contrast to the pn structure normally found in traditional silicon-avalanche TVS diodes. The EPD mechanism is achieved by engineering the center region of the device such that the reverse biased junction does

**PROTECTION PRODUCTS**

**Applications Information (continued)**

not avalanche, but will “punch-through” to a conducting state. This structure results in a device with superior dc electrical parameters at low voltages while maintaining the capability to absorb high transient currents.

The IV characteristic curve of the EPD device is shown in Figure 1. The device represents a high impedance to the circuit up to the working voltage ( $V_{RWM}$ ). During a transient event, the device will begin to conduct as it is biased in the reverse direction. When the punch-through voltage ( $V_{PT}$ ) is exceeded, the device enters a low impedance state, diverting the transient current away from the protected circuit. When the device is conducting current, it will exhibit a slight “snap-back” or negative resistance characteristic due to its structure. This must be considered when connecting the device to a power supply rail. To return to a non-conducting state, the current through the device must fall below the snap-back current (approximately < 50mA).

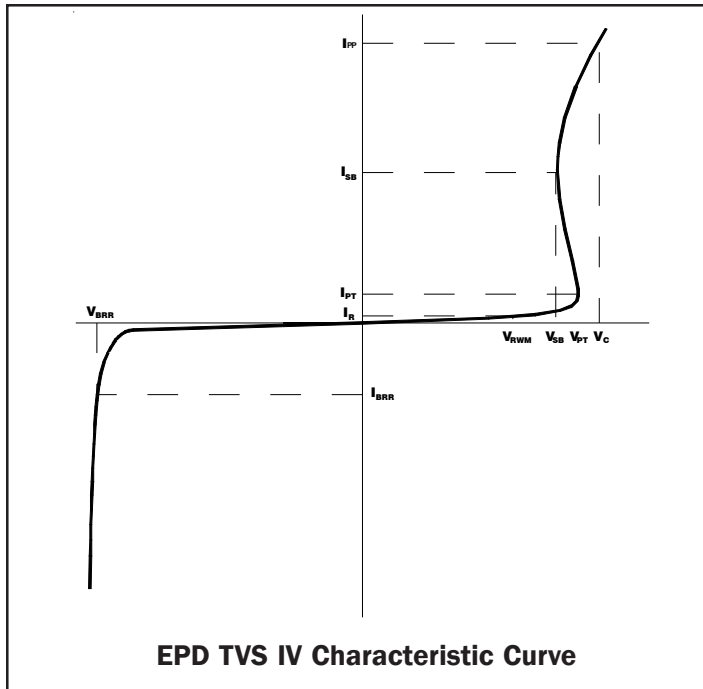

**EPD TVS IV Characteristic Curve**

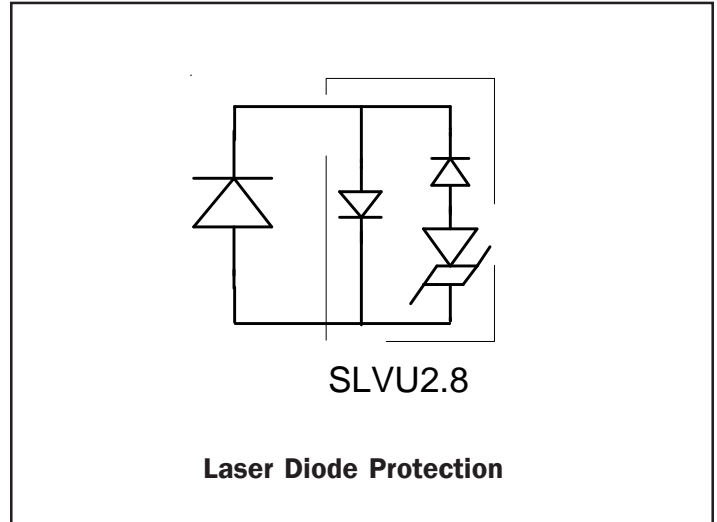

**SLVU2.8**

**Laser Diode Protection**

**Circuit Board Layout Recommendations for Suppression of ESD.**

Good circuit board layout is critical for the suppression of ESD induced transients. The following guidelines are recommended:

- Place the SLVU2.8 near the input terminals or connectors to restrict transient coupling.
- Minimize the path length between the TVS and the protected line.
- Minimize all conductive loops including power and ground loops.
- The ESD transient return path to ground should be kept as short as possible.
- Never run critical signals near board edges.
- Use ground planes whenever possible.

**Matte Tin Lead Finish**

Matte tin has become the industry standard lead-free replacement for SnPb lead finishes. A matte tin finish is composed of 100% tin solder with large grains. Since the solder volume on the leads is small compared to the solder paste volume that is placed on the land pattern of the PCB, the reflow profile will be determined by the requirements of the solder paste. Therefore, these devices are compatible with both lead-free and SnPb assembly techniques. In addition, unlike other lead-free compositions, matte tin does not have any added alloys that can cause degradation of the solder joint.

PROTECTION PRODUCTS

Typical Applications

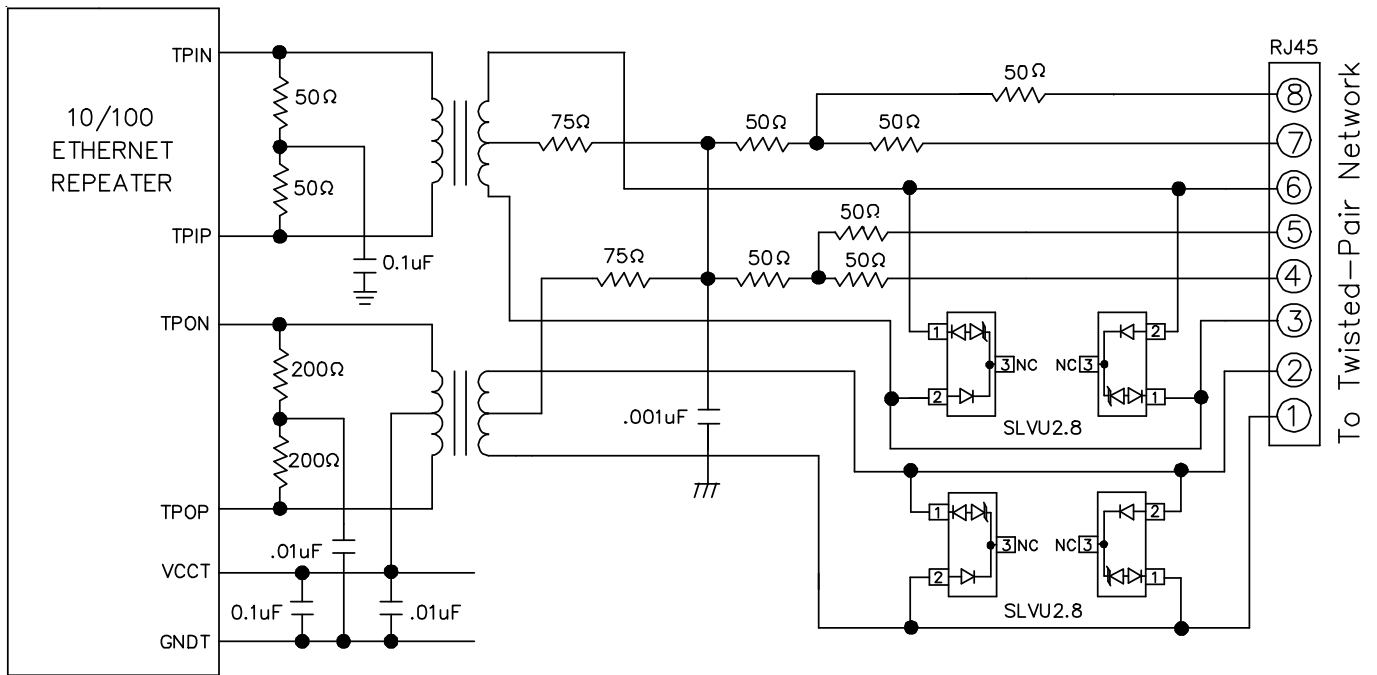

**10/100 Ethernet Protection Circuit**  
 (Reference Semtech Application Note SI98-02 for more information)

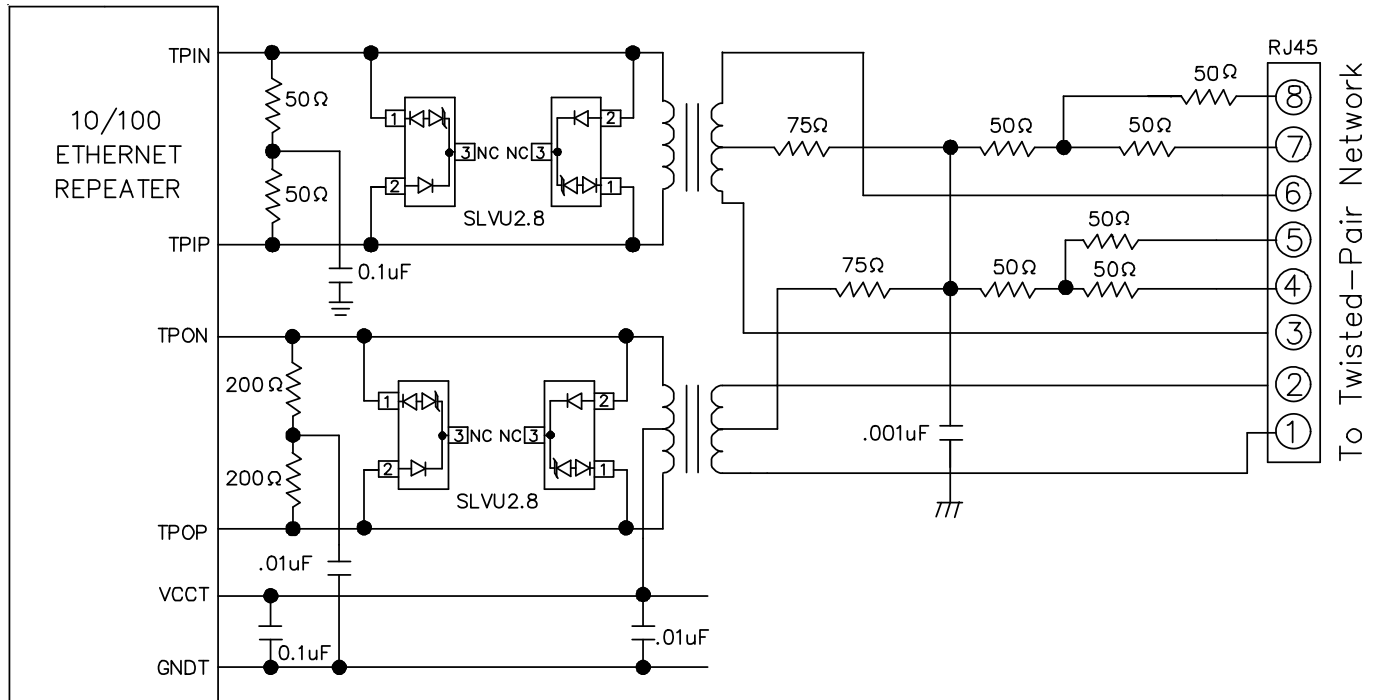

**10/100 Ethernet "Enhanced" Lightning Protection Circuit**  
 (Reference Semtech Application Note SI98-02 for more information)

PROTECTION PRODUCTS

Applications Information - SPICE Model

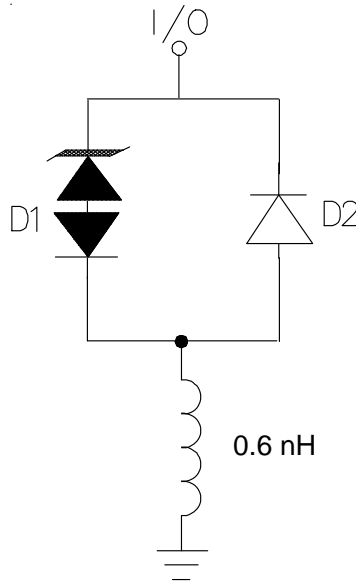

SLVU2.8 Spice Model

SLVU2.8 Spice Parameters			
Parameter	Unit	D1 (TVS)	D2 (LCRD)
IS	Amp	6.09E-14	8.57E-9
BV	Volt	3.4	420
VJ	Volt	13.8	0.62
RS	Ohm	0.389	0.15
IBV	Amp	10E-3	10E-3
CJO	Farad	24.75E-12	3.15E-12
TT	sec	2.541E-9	2.541E-9
M	--	0.145	0.113
N	--	1.1	1.1
EG	eV	1.11	1.11

PROTECTION PRODUCTS

Outline Drawing - SOT23

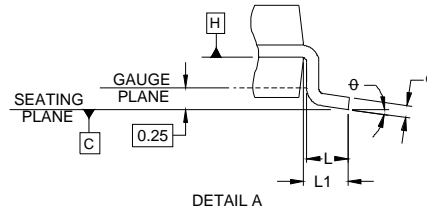
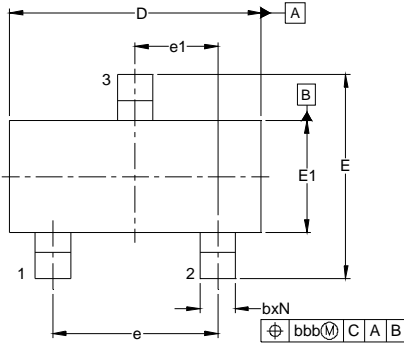

DIM	INCHES			MILLIMETERS		
	MIN	NOM	MAX	MIN	NOM	MAX
A	.035	-	.044	0.89	-	1.12
A1	.000	-	.004	0.01	-	0.10
A2	.035	.037	.040	0.88	0.95	1.02
b	.012	-	.020	0.30	-	0.51
c	.003	-	.007	0.08	-	0.18
D	.110	.114	.120	2.80	2.90	3.04
E	.082	.093	.104	2.10	2.37	2.64
E1	.047	.051	.055	1.20	1.30	1.40
e	.075 1.90 BSC					
e1	.037 0.95 BSC					
L	.015	.020	.024	0.40	0.50	0.60
L1	.022 (0.55)					
N	3					
theta	0° - 8°		0° - 8°			
aaa	.004 0.10					
bbb	.008 0.20					

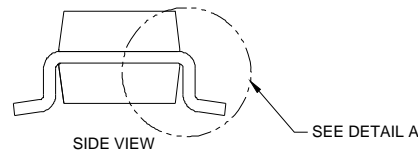
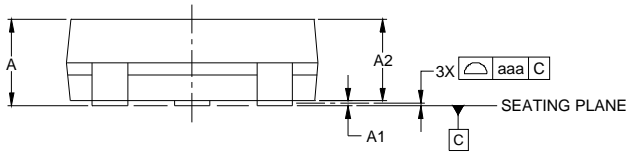

NOTES:

1. CONTROLLING DIMENSIONS ARE IN MILLIMETERS (ANGLES IN DEGREES).
2. DATUMS **-A-** AND **-B-** TO BE DETERMINED AT DATUM PLANE **-H-**
3. DIMENSIONS "E1" AND "D" DO NOT INCLUDE MOLD FLASH, PROTRUSIONS OR GATE BURRS.

Land Pattern - SOT23

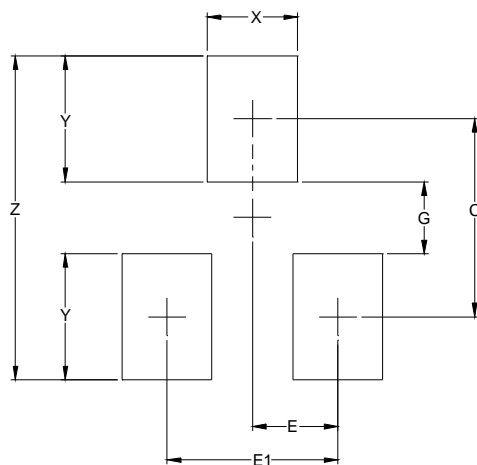

DIMENSIONS		
DIM	INCHES	MILLIMETERS
C	(.087)	(2.20)
E	.037	0.95
E1	.075	1.90
G	.031	0.80
X	.039	1.00
Y	.055	1.40
Z	.141	3.60

NOTES:

1. THIS LAND PATTERN IS FOR REFERENCE PURPOSES ONLY CONSULT YOUR MANUFACTURING GROUP TO ENSURE YOUR COMPANY'S MANUFACTURING GUIDELINES ARE MET.
2. REFERENCE IPC-SM-782A.

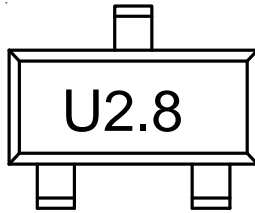
**PROTECTION PRODUCTS****Marking****Ordering Information**

<b>Part Number</b>	<b>Lead Finish</b>	<b>Qty per Reel</b>	<b>Reel Size</b>
SLVU2.8.TC	SnPb	3,000	7 Inch
SLVU2.8.TCT	Pb free	3,000	7 Inch

**Contact Information**

Semtech Corporation  
Protection Products Division  
200 Flynn Road, Camarillo, CA 93012  
Phone: (805)498-2111 FAX (805)498-3804

## Looking for pricing, stock, or lifecycle information?

Click below to explore more details on WIN SOURCE:

- ⊖ [View SLVU2.8.TCT on WIN SOURCE](#)
- ⊖ [Semtech Corporation](#) Information

## Optimize Your Supply Chain with WIN SOURCE Solutions

- ✓ Global Sourcing Solution
- ✓ Obsolete Management
- ✓ Cost Control Management
- ✓ Shortage Management
- ✓ Alternative Solution
- ✓ Excess Inventory Management