



**THE DATASHEET OF  
74CBTLV3861DK,118**



## Important notice

Dear Customer,

On 7 February 2017 the former NXP Standard Product business became a new company with the tradename **Nexperia**. Nexperia is an industry leading supplier of Discrete, Logic and PowerMOS semiconductors with its focus on the automotive, industrial, computing, consumer and wearable application markets

In data sheets and application notes which still contain NXP or Philips Semiconductors references, use the references to Nexperia, as shown below.

Instead of <http://www.nxp.com>, <http://www.philips.com/> or <http://www.semiconductors.philips.com/>, use <http://www.nexperia.com>

Instead of [sales.addresses@www.nxp.com](mailto:sales.addresses@www.nxp.com) or [sales.addresses@www.semiconductors.philips.com](mailto:sales.addresses@www.semiconductors.philips.com), use [salesaddresses@nexperia.com](mailto:salesaddresses@nexperia.com) (email)

Replace the copyright notice at the bottom of each page or elsewhere in the document, depending on the version, as shown below:

- © NXP N.V. (year). All rights reserved or © Koninklijke Philips Electronics N.V. (year). All rights reserved

Should be replaced with:

- © **Nexperia B.V. (year). All rights reserved.**

If you have any questions related to the data sheet, please contact our nearest sales office via e-mail or telephone (details via [salesaddresses@nexperia.com](mailto:salesaddresses@nexperia.com)). Thank you for your cooperation and understanding,

Kind regards,

Team Nexperia

# 74CBTLV3861

## 10-bit bus switch with output enable

Rev. 4 — 11 November 2016

Product data sheet

## 1. General description

---

The 74CBTLV3861 is a 10-bit bus switch with one output enable ( $\overline{OE}$ ) input. When  $\overline{OE}$  is LOW, the switch is closed and port A is connected to the B port. When  $\overline{OE}$  is HIGH, the switch is disabled.

To ensure the high-impedance OFF-state during power-up or power-down,  $\overline{OE}$  should be tied to the  $V_{CC}$  through a pull-up resistor. The minimum value of the resistor is determined by the current-sinking capability of the driver.

Schmitt trigger action at control input makes the circuit tolerant to slower input rise and fall times across the entire  $V_{CC}$  range from 2.3 V to 3.6 V.

This device is fully specified for partial power-down applications using  $I_{OFF}$ . The  $I_{OFF}$  circuitry disables the output, preventing the damaging backflow current through the device when it is powered down.

## 2. Features and benefits

---

- Supply voltage range from 2.3 V to 3.6 V
- High noise immunity
- Complies with JEDEC standard:
  - ◆ JESD8-5 (2.3 V to 2.7 V)
  - ◆ JESD8-B/JESD36 (2.7 V to 3.6 V)
- ESD protection:
  - ◆ HBM JESD22-A114F exceeds 2000 V
  - ◆ MM JESD22-A115-A exceeds 200 V
  - ◆ CDM AEC-Q100-011 revision B exceeds 1000 V
- 5  $\Omega$  switch connection between two ports
- Rail to rail switching on data I/O ports
- CMOS low power consumption
- Latch-up performance exceeds 250 mA per JESD78B Class I level A
- $I_{OFF}$  circuitry provides partial Power-down mode operation
- Multiple package options
- Specified from  $-40\text{ }^{\circ}\text{C}$  to  $+85\text{ }^{\circ}\text{C}$  and  $-40\text{ }^{\circ}\text{C}$  to  $+125\text{ }^{\circ}\text{C}$



### 3. Ordering information

Table 1. Ordering information

Type number	Package			Version
	Temperature range	Name	Description	
74CBTLV3861DK	-40 °C to +125 °C	SSOP24 <sup>[1]</sup>	plastic shrink small outline package; 24 leads; body width 3.9 mm; lead pitch 0.635 mm	SOT556-1
74CBTLV3861PW	-40 °C to +125 °C	TSSOP24	plastic thin shrink small outline package; 24 leads; body width 4.4 mm	SOT355-1
74CBTLV3861BQ	-40 °C to +125 °C	DHVQFN24	plastic dual in-line compatible thermal enhanced very thin quad flat package; no leads; 24 terminals; body 3.5 × 5.5 × 0.85 mm	SOT815-1

[1] Also known as QSOP24 package

### 4. Functional diagram

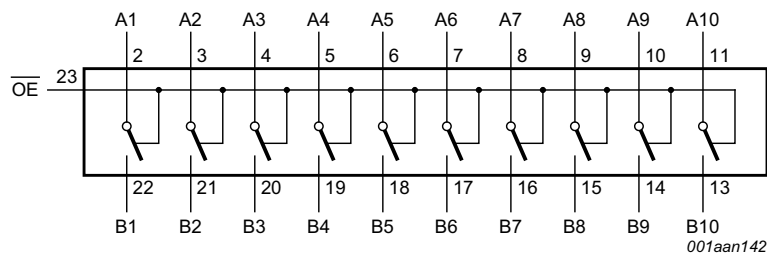

Fig 1. Logic symbol

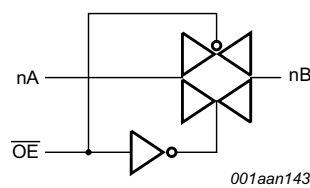

Fig 2. Logic diagram (one switch)

5. Pinning information

5.1 Pinning

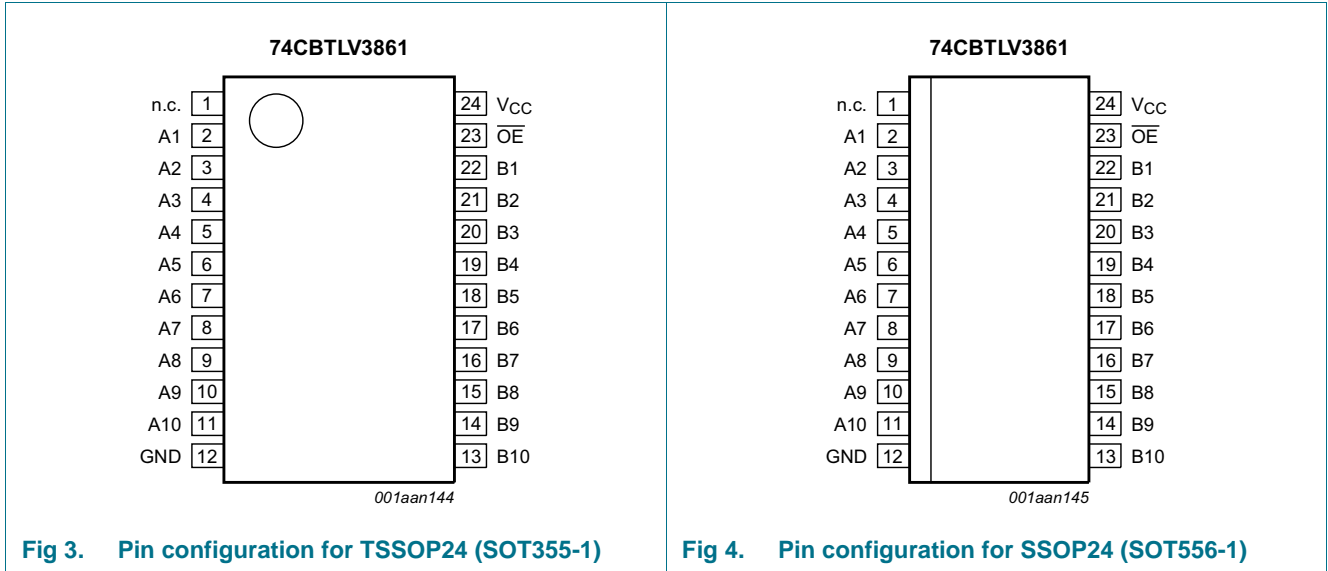

Fig 3. Pin configuration for TSSOP24 (SOT355-1)

Fig 4. Pin configuration for SSOP24 (SOT556-1)

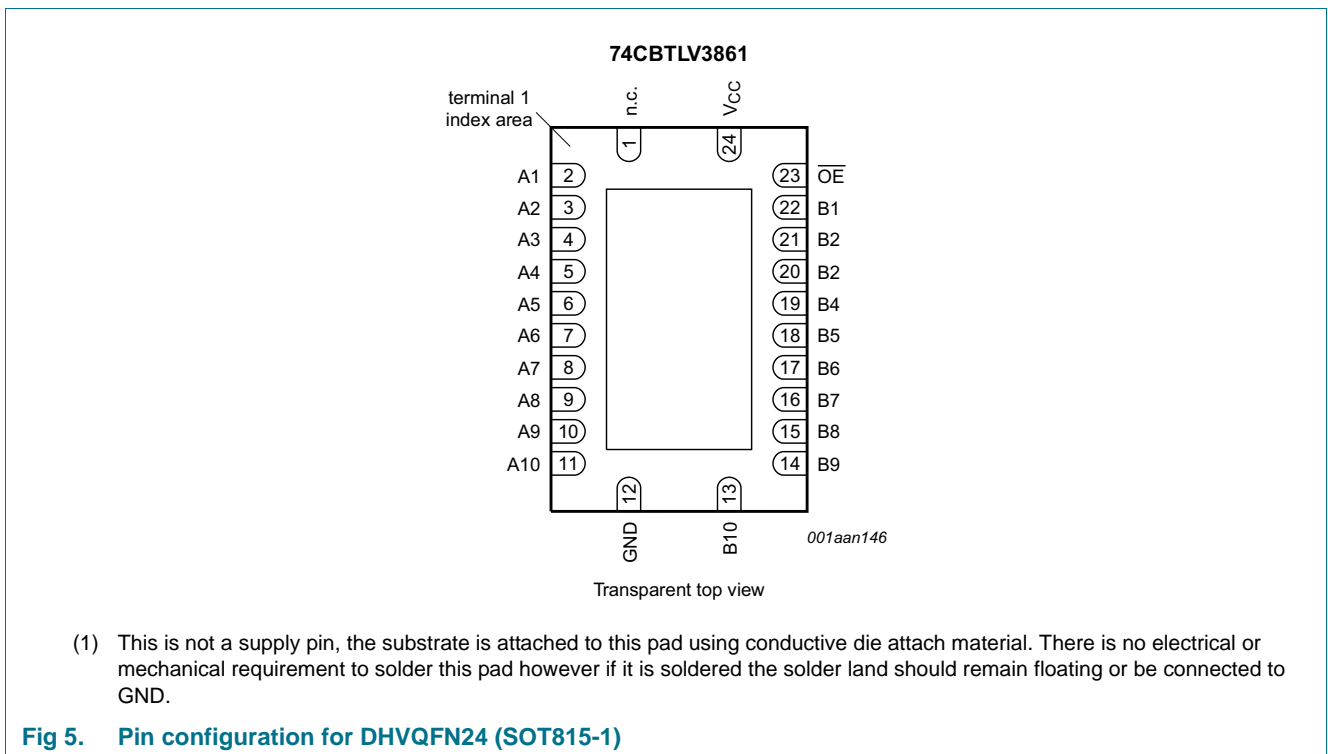

Fig 5. Pin configuration for DHVQFN24 (SOT815-1)

## 5.2 Pin description

Table 2. Pin description

Symbol	Pin	Description
n.c.	1	not connected
A1 to A10	2, 3, 4, 5, 6, 7, 8, 9, 10, 11	data input/output (A port)
GND	12	ground (0 V)
B1 to B10	22, 21, 20, 19, 18, 17, 16, 15, 14, 13	data input/output (B port)
$\overline{OE}$	23	output enable input (active LOW)
V <sub>CC</sub>	24	positive supply voltage

## 6. Functional description

Table 3. Function selection<sup>[1]</sup>

Input	Input/output
$\overline{OE}$	An, Bn
L	An = Bn
H	Z

[1] H = HIGH voltage level; L = LOW voltage level; Z = high-impedance OFF-state.

## 7. Limiting values

Table 4. Limiting values

In accordance with the Absolute Maximum Rating System (IEC 60134). Voltages are referenced to GND (ground = 0 V).

Symbol	Parameter	Conditions	Min	Max	Unit
V <sub>CC</sub>	supply voltage		-0.5	+4.6	V
V <sub>I</sub>	input voltage		-0.5	+4.6	V
V <sub>SW</sub>	switch voltage	enable and disable mode	-0.5	V <sub>CC</sub> + 0.5	V
I <sub>IK</sub>	input clamping current	V <sub>I</sub> < -0.5 V	-50	-	mA
I <sub>SK</sub>	switch clamping current	V <sub>I</sub> < -0.5 V	-50	-	mA
I <sub>SW</sub>	switch current	V <sub>SW</sub> = 0 V to V <sub>CC</sub>	-	±128	mA
I <sub>CC</sub>	supply current		-	+100	mA
I <sub>GND</sub>	ground current		-100	-	mA
T <sub>stg</sub>	storage temperature		-65	+150	°C
P <sub>tot</sub>	total power dissipation	T <sub>amb</sub> = -40 °C to +125 °C	-	500	mW

[1] The minimum input and output voltage ratings may be exceeded if the input and output current ratings are observed.

[2] For SSOP24 and TSSOP24 packages: P<sub>tot</sub> derates linearly with 5.5 mW/K above 60 °C.  
For DHVQFN24 package: P<sub>tot</sub> derates linearly at 4.5 mW/K above 60 °C.

## 8. Recommended operating conditions

**Table 5. Recommended operating conditions**

Symbol	Parameter	Conditions	Min	Max	Unit
$V_{CC}$	supply voltage		2.3	3.6	V
$V_I$	input voltage		0	3.6	V
$V_{SW}$	switch voltage	enable and disable mode	0	$V_{CC}$	V
$T_{amb}$	ambient temperature		-40	+125	°C
$\Delta t/\Delta V$	input transition rise and fall rate	$V_{CC} = 2.3\text{ V to }3.6\text{ V}$ [1]	-	200	ns/V

[1] Applies to control signal levels.

## 9. Static characteristics

**Table 6. Static characteristics**

At recommended operating conditions voltages are referenced to GND (ground = 0 V).

Symbol	Parameter	Conditions	$T_{amb} = -40\text{ °C to }+85\text{ °C}$			$T_{amb} = -40\text{ °C to }+125\text{ °C}$		Unit
			Min	Typ[1]	Max	Min	Max	
$V_{IH}$	HIGH-level input voltage	$V_{CC} = 2.3\text{ V to }2.7\text{ V}$	1.7	-	-	1.7	-	V
		$V_{CC} = 3.0\text{ V to }3.6\text{ V}$	2.0	-	-	2.0	-	V
$V_{IL}$	LOW-level input voltage	$V_{CC} = 2.3\text{ V to }2.7\text{ V}$	-	-	0.7	-	0.7	V
		$V_{CC} = 3.0\text{ V to }3.6\text{ V}$	-	-	0.9	-	0.9	V
$I_I$	input leakage current	pin $\overline{OE}$ ; $V_I = \text{GND to }V_{CC}$ ; $V_{CC} = 3.6\text{ V}$	-	-	$\pm 1$	-	$\pm 20$	$\mu\text{A}$
$I_{S(OFF)}$	OFF-state leakage current	$V_{CC} = 3.6\text{ V}$ ; see <a href="#">Figure 6</a>	-	-	$\pm 1$	-	$\pm 20$	$\mu\text{A}$
$I_{S(ON)}$	ON-state leakage current	$V_{CC} = 3.6\text{ V}$ ; see <a href="#">Figure 7</a>	-	-	$\pm 1$	-	$\pm 20$	$\mu\text{A}$
$I_{OFF}$	power-off leakage current	$V_I$ or $V_O = 0\text{ V to }3.6\text{ V}$ ; $V_{CC} = 0\text{ V}$	-	-	$\pm 10$	-	$\pm 50$	$\mu\text{A}$
$I_{CC}$	supply current	$V_I = \text{GND or }V_{CC}$ ; $I_O = 0\text{ A}$ ; $V_{SW} = \text{GND or }V_{CC}$ ; $V_{CC} = 3.6\text{ V}$	-	-	10	-	50	$\mu\text{A}$
$\Delta I_{CC}$	additional supply current	pin $\overline{OE}$ ; $V_I = V_{CC} - 0.6\text{ V}$ ; $V_{SW} = \text{GND or }V_{CC}$ ; $V_{CC} = 3.6\text{ V}$ [2]	-	-	300	-	2000	$\mu\text{A}$
$C_I$	input capacitance	pin $\overline{OE}$ ; $V_{CC} = 3.3\text{ V}$ ; $V_I = 0\text{ V to }3.3\text{ V}$	-	0.9	-	-	-	pF
$C_{S(OFF)}$	OFF-state capacitance	$V_{CC} = 3.3\text{ V}$ ; $V_I = 0\text{ V to }3.3\text{ V}$	-	5.2	-	-	-	pF
$C_{S(ON)}$	ON-state capacitance	$V_{CC} = 3.3\text{ V}$ ; $V_I = 0\text{ V to }3.3\text{ V}$	-	14.3	-	-	-	pF

[1] All typical values are measured at  $T_{amb} = 25\text{ °C}$ .

[2] One input at 3 V, other inputs at  $V_{CC}$  or GND.

9.1 Test circuits

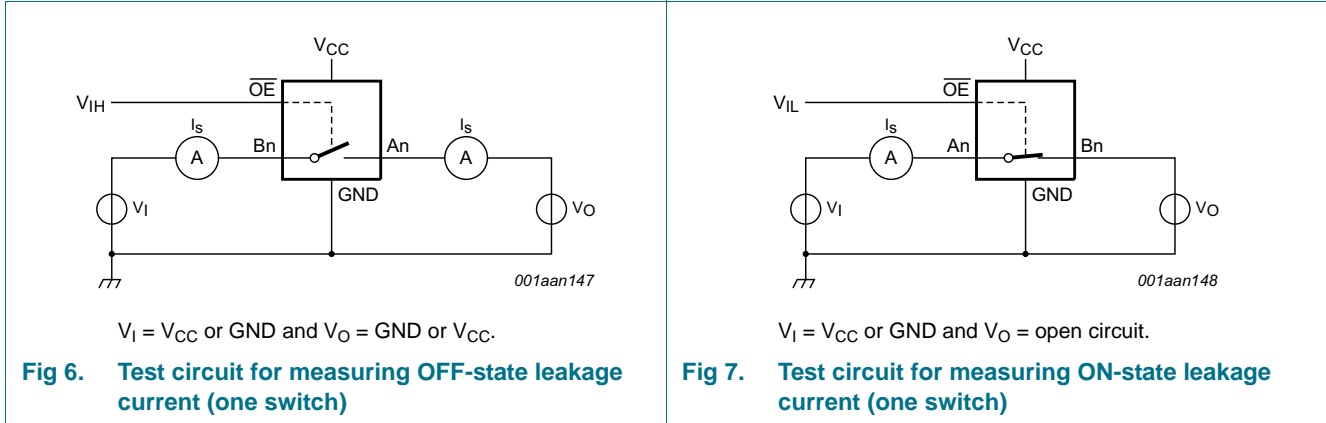

9.2 ON resistance

Table 7. Resistance  $R_{ON}$

At recommended operating conditions; voltages are referenced to GND (ground = 0 V); for test circuit see Figure 8.

Symbol	Parameter	Conditions	$T_{amb} = -40\text{ °C to }+85\text{ °C}$			$T_{amb} = -40\text{ °C to }+125\text{ °C}$		Unit
			Min	Typ <sup>[1]</sup>	Max	Min	Max	
$R_{ON}$	ON resistance	$V_{CC} = 2.3\text{ V to }2.7\text{ V}$ ; see Figure 9 to Figure 11 [2]						
		$I_{SW} = 64\text{ mA}$ ; $V_I = 0\text{ V}$	-	4.2	8.0	-	15.0	$\Omega$
		$I_{SW} = 24\text{ mA}$ ; $V_I = 0\text{ V}$	-	4.2	8.0	-	15.0	$\Omega$
		$I_{SW} = 15\text{ mA}$ ; $V_I = 1.7\text{ V}$	-	8.4	40	-	60.0	$\Omega$
		$V_{CC} = 3.0\text{ V to }3.6\text{ V}$ ; see Figure 12 to Figure 14						
		$I_{SW} = 64\text{ mA}$ ; $V_I = 0\text{ V}$	-	4.0	7.0	-	11.0	$\Omega$
		$I_{SW} = 24\text{ mA}$ ; $V_I = 0\text{ V}$	-	4.0	7.0	-	11.0	$\Omega$
$I_{SW} = 15\text{ mA}$ ; $V_I = 2.4\text{ V}$	-	6.2	15	-	25.5	$\Omega$		

- [1] Typical values are measured at  $T_{amb} = 25\text{ °C}$  and nominal  $V_{CC}$ .
- [2] Measured by the voltage drop between the A and B terminals at the indicated current through the switch. ON-state resistance is determined by the lower of the voltages of the two (A or B) terminals.

9.3 ON resistance test circuit and graphs

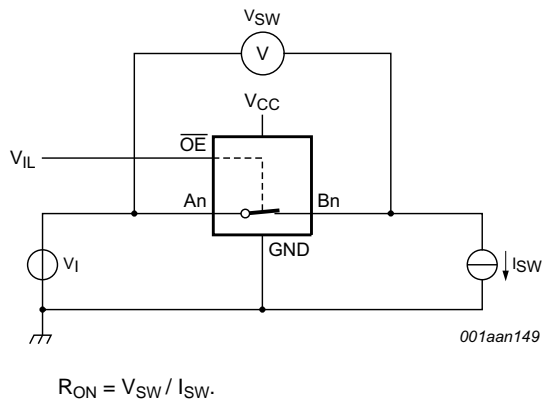
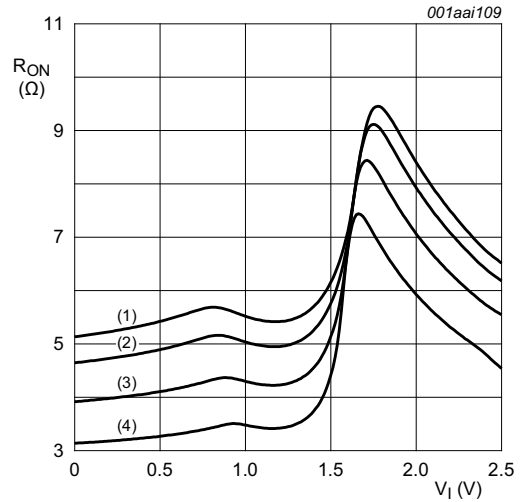
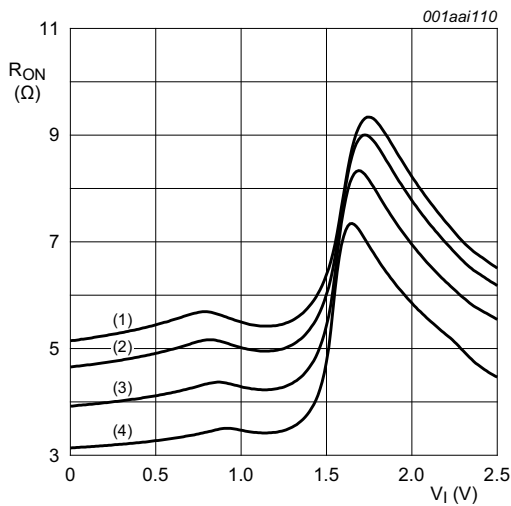

Fig 8. Test circuit for measuring ON resistance (one switch)



- (1)  $T_{amb} = 125\text{ }^{\circ}\text{C}$ .
- (2)  $T_{amb} = 85\text{ }^{\circ}\text{C}$ .
- (3)  $T_{amb} = 25\text{ }^{\circ}\text{C}$ .
- (4)  $T_{amb} = -40\text{ }^{\circ}\text{C}$ .

Fig 9. ON resistance as a function of input voltage;  $V_{CC} = 2.5\text{ V}$ ;  $I_{SW} = 15\text{ mA}$



- (1)  $T_{amb} = 125\text{ }^{\circ}\text{C}$ .
- (2)  $T_{amb} = 85\text{ }^{\circ}\text{C}$ .
- (3)  $T_{amb} = 25\text{ }^{\circ}\text{C}$ .
- (4)  $T_{amb} = -40\text{ }^{\circ}\text{C}$ .

Fig 10. ON resistance as a function of input voltage;  $V_{CC} = 2.5\text{ V}$ ;  $I_{SW} = 24\text{ mA}$

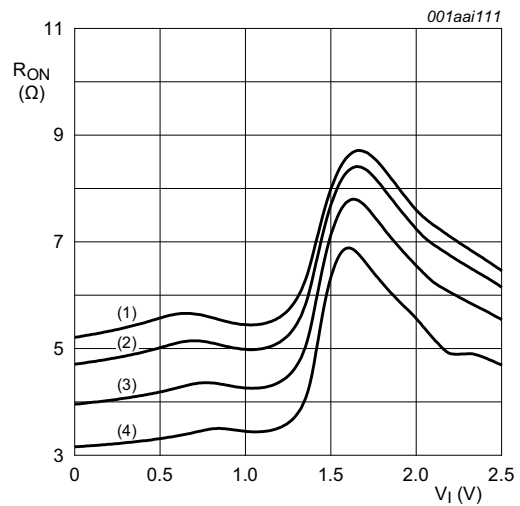

- (1)  $T_{amb} = 125\text{ }^{\circ}\text{C}$ .
- (2)  $T_{amb} = 85\text{ }^{\circ}\text{C}$ .
- (3)  $T_{amb} = 25\text{ }^{\circ}\text{C}$ .
- (4)  $T_{amb} = -40\text{ }^{\circ}\text{C}$ .

Fig 11. ON resistance as a function of input voltage;  $V_{CC} = 2.5\text{ V}$ ;  $I_{SW} = 64\text{ mA}$

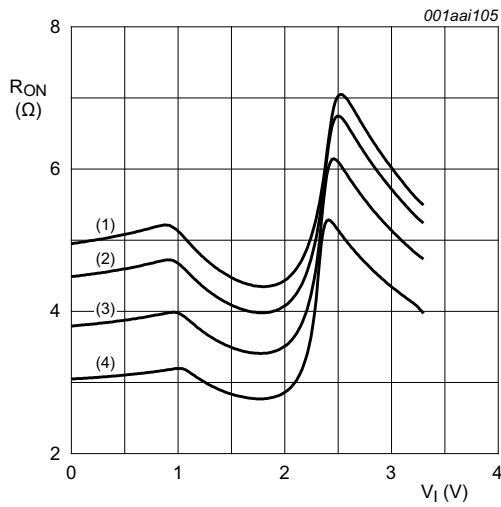

- (1)  $T_{amb} = 125\text{ }^{\circ}\text{C}.$
- (2)  $T_{amb} = 85\text{ }^{\circ}\text{C}.$
- (3)  $T_{amb} = 25\text{ }^{\circ}\text{C}.$
- (4)  $T_{amb} = -40\text{ }^{\circ}\text{C}.$

**Fig 12. ON resistance as a function of input voltage;**  
 $V_{CC} = 3.3\text{ V}; I_{SW} = 15\text{ mA}$

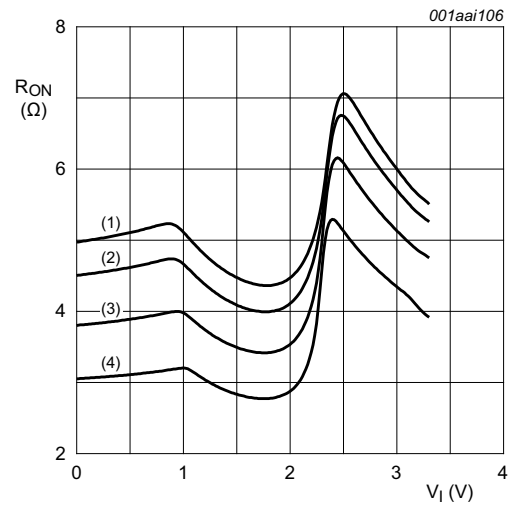

- (1)  $T_{amb} = 125\text{ }^{\circ}\text{C}.$
- (2)  $T_{amb} = 85\text{ }^{\circ}\text{C}.$
- (3)  $T_{amb} = 25\text{ }^{\circ}\text{C}.$
- (4)  $T_{amb} = -40\text{ }^{\circ}\text{C}.$

**Fig 13. ON resistance as a function of input voltage;**  
 $V_{CC} = 3.3\text{ V}; I_{SW} = 24\text{ mA}$

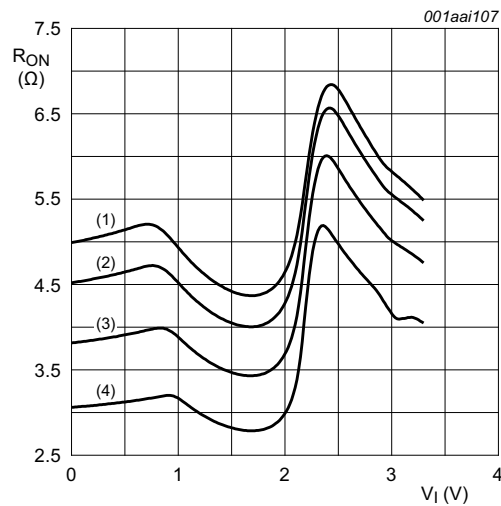

- (1)  $T_{amb} = 125\text{ }^{\circ}\text{C}.$
- (2)  $T_{amb} = 85\text{ }^{\circ}\text{C}.$
- (3)  $T_{amb} = 25\text{ }^{\circ}\text{C}.$
- (4)  $T_{amb} = -40\text{ }^{\circ}\text{C}.$

**Fig 14. ON resistance as a function of input voltage;**  
 $V_{CC} = 3.3\text{ V}; I_{SW} = 64\text{ mA}$

## 10. Dynamic characteristics

**Table 8. Dynamic characteristics**  
*GND = 0 V; for test circuit see Figure 17*

Symbol	Parameter	Conditions	T <sub>amb</sub> = -40 °C to +85 °C			T <sub>amb</sub> = -40 °C to +125 °C		Unit
			Min	Typ <sup>[1]</sup>	Max	Min	Max	
t <sub>pd</sub>	propagation delay	An to Bn or Bn to An; see Figure 15 <sup>[2][3]</sup>						
		V <sub>CC</sub> = 2.3 V to 2.7 V	-	-	0.13	-	0.20	ns
		V <sub>CC</sub> = 3.0 V to 3.6 V	-	-	0.20	-	0.31	ns
t <sub>en</sub>	enable time	$\overline{OE}$ to An or Bn; see Figure 16 <sup>[4]</sup>						
		V <sub>CC</sub> = 2.3 V to 2.7 V	1.0	2.9	5.5	1.0	8.0	ns
		V <sub>CC</sub> = 3.0 V to 3.6 V	1.0	2.4	4.9	1.0	7.0	ns
t <sub>dis</sub>	disable time	$\overline{OE}$ to An or Bn; see Figure 16 <sup>[5]</sup>						
		V <sub>CC</sub> = 2.3 V to 2.7 V	1.0	2.6	5.5	1.0	8.0	ns
		V <sub>CC</sub> = 3.0 V to 3.6 V	1.0	3.1	5.8	1.0	8.5	ns

- [1] All typical values are measured at T<sub>amb</sub> = 25 °C and at nominal V<sub>CC</sub>.
- [2] The propagation delay is the calculated RC time constant of the typical on-state resistance of the switch and the load capacitance, when driven by an ideal voltage source (zero output impedance).
- [3] t<sub>pd</sub> is the same as t<sub>PLH</sub> and t<sub>PHL</sub>.
- [4] t<sub>en</sub> is the same as t<sub>PZH</sub> and t<sub>PZL</sub>.
- [5] t<sub>dis</sub> is the same as t<sub>PHZ</sub> and t<sub>PLZ</sub>.

## 11. Waveforms

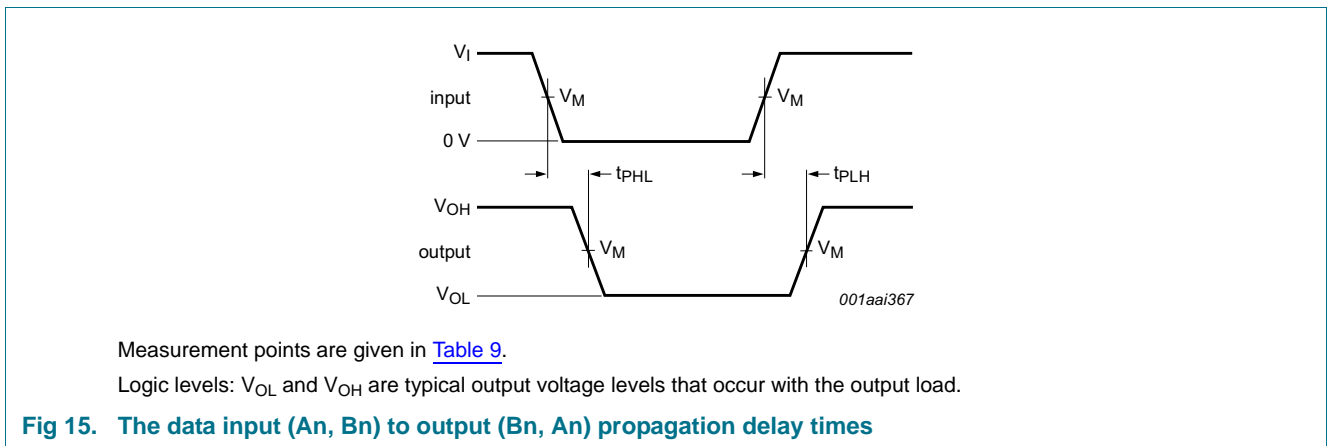

**Table 9. Measurement points**

Supply voltage	Input			Output		
V <sub>CC</sub>	V <sub>M</sub>	V <sub>I</sub>	t <sub>r</sub> = t <sub>f</sub>	V <sub>M</sub>	V <sub>X</sub>	V <sub>Y</sub>
2.3 V to 2.7 V	0.5V <sub>CC</sub>	V <sub>CC</sub>	≤ 2.0 ns	0.5V <sub>CC</sub>	V <sub>OL</sub> + 0.15 V	V <sub>OH</sub> - 0.15 V
3.0 V to 3.6 V	0.5V <sub>CC</sub>	V <sub>CC</sub>	≤ 2.0 ns	0.5V <sub>CC</sub>	V <sub>OL</sub> + 0.3 V	V <sub>OH</sub> - 0.3 V

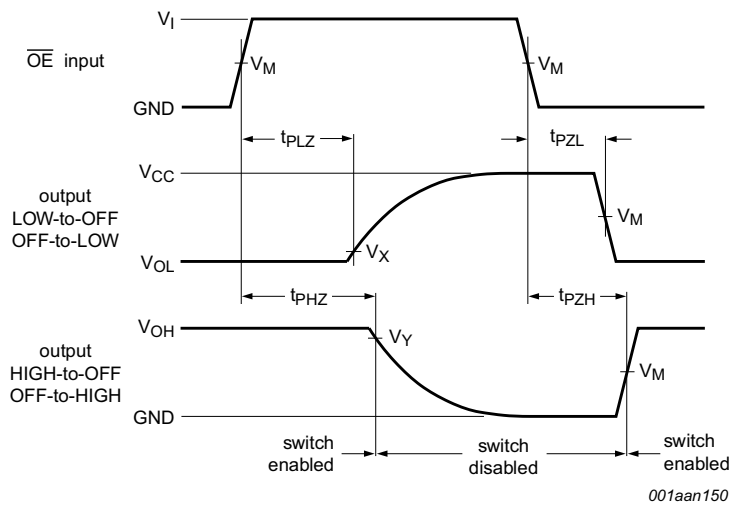

Measurement points are given in [Table 9](#).

Logic levels:  $V_{OL}$  and  $V_{OH}$  are typical output voltage levels that occur with the output load.

**Fig 16. Enable and disable times**

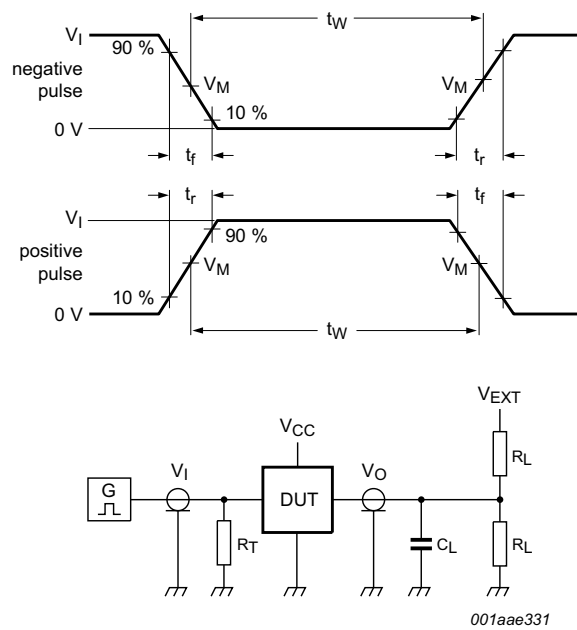

Test data is given in [Table 10](#).

Definitions for test circuit:

$R_L$  = Load resistance.

$C_L$  = Load capacitance including jig and probe capacitance.

$R_T$  = Termination resistance should be equal to the output impedance  $Z_o$  of the pulse generator.

$V_{EXT}$  = External voltage for measuring switching times.

**Fig 17. Test circuit for measuring switching times**

**Table 10. Test data**

Supply voltage	Load		$V_{EXT}$		
	$C_L$	$R_L$	$t_{PLH}, t_{PHL}$	$t_{PZH}, t_{PHZ}$	$t_{PZL}, t_{PLZ}$
2.3 V to 2.7 V	30 pF	500 $\Omega$	open	GND	$2V_{CC}$
3.0 V to 3.6 V	50 pF	500 $\Omega$	open	GND	$2V_{CC}$

### 11.1 Additional dynamic characteristics

Table 11. Additional dynamic characteristics

GND = 0 V.

Symbol	Parameter	Conditions	T <sub>amb</sub> = 25 °C			Unit
			Min	Typ	Max	
f <sub>(-3dB)</sub>	-3 dB frequency response	V <sub>CC</sub> = 3.3 V; R <sub>L</sub> = 50 Ω; see <a href="#">Figure 18</a> [1]	-	406	-	MHz

[1] f<sub>i</sub> is biased at 0.5V<sub>CC</sub>.

### 11.2 Test circuit

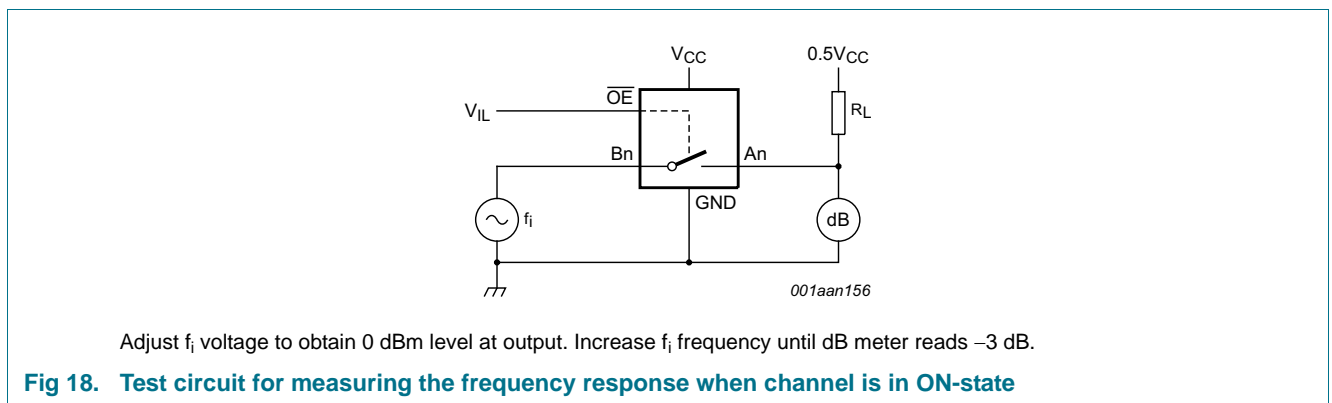

12. Package outline

SSOP24: plastic shrink small outline package; 24 leads; body width 3.9 mm; lead pitch 0.635 mm SOT556-1

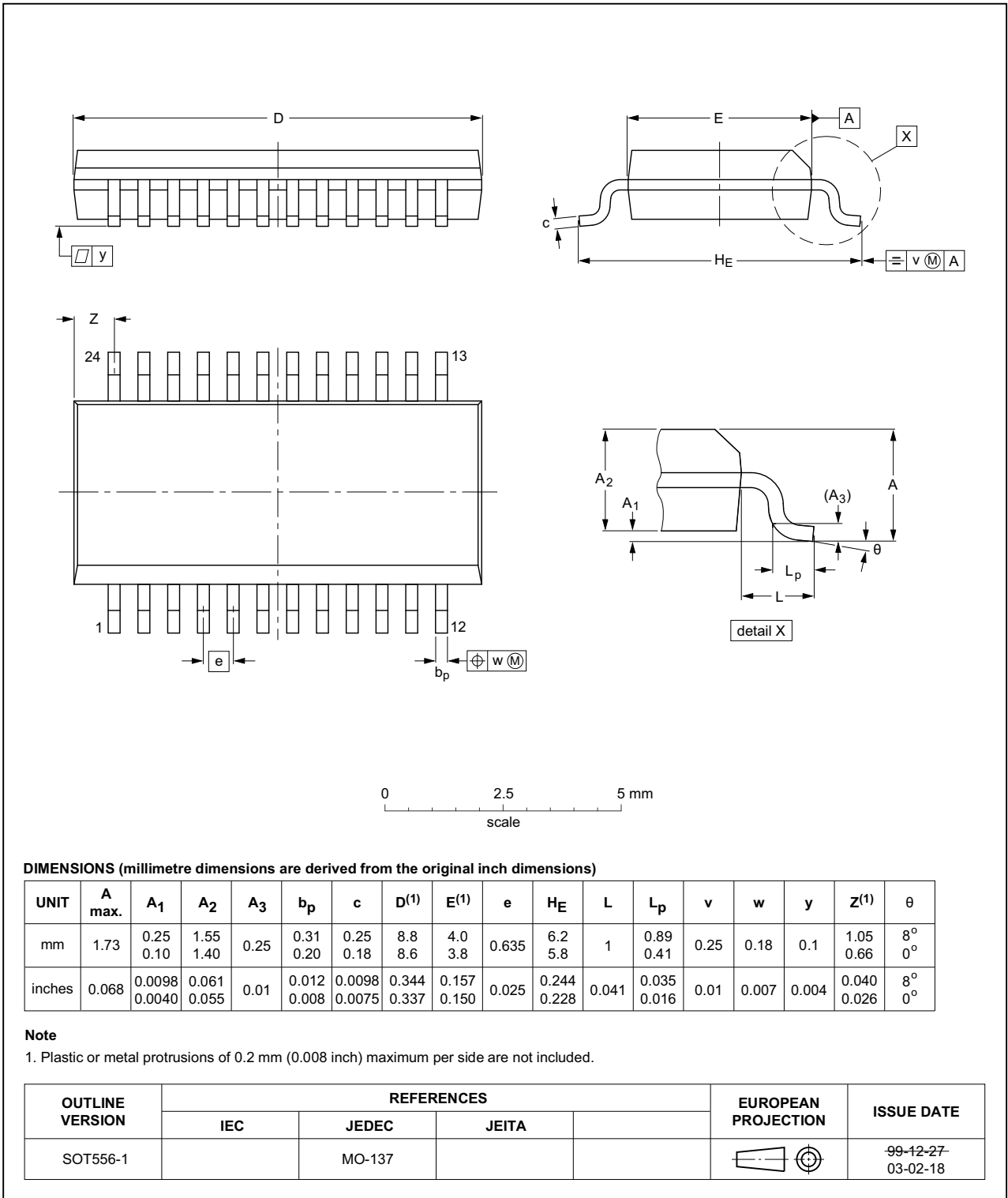

Fig 19. Package outline SOT556-1 (SSOP24)

TSSOP24: plastic thin shrink small outline package; 24 leads; body width 4.4 mm

SOT355-1

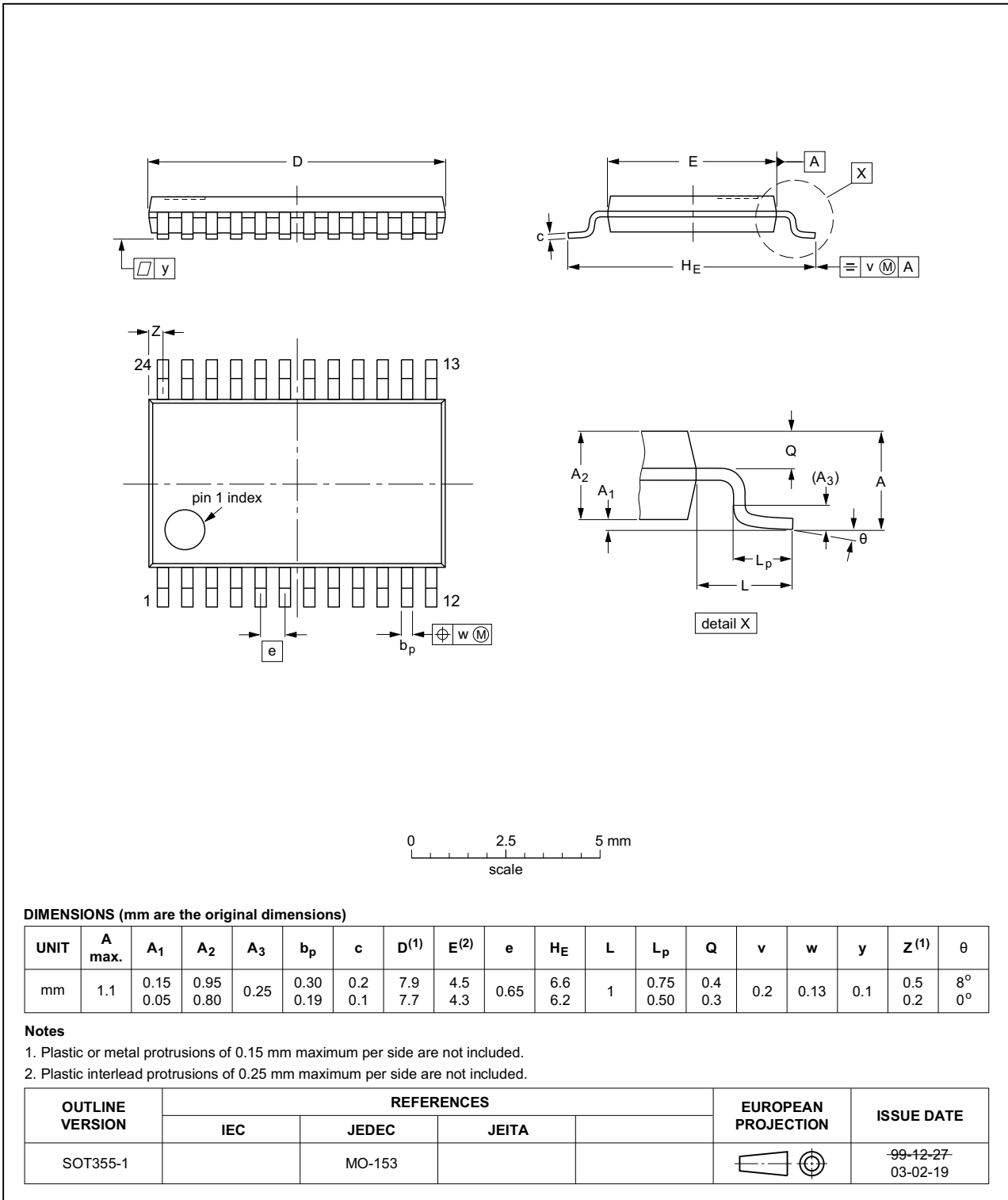

Fig 20. Package outline SOT355-1 (TSSOP24)

DHVQFN24: plastic dual in-line compatible thermal enhanced very thin quad flat package; no leads; 24 terminals; body 3.5 x 5.5 x 0.85 mm

SOT815-1

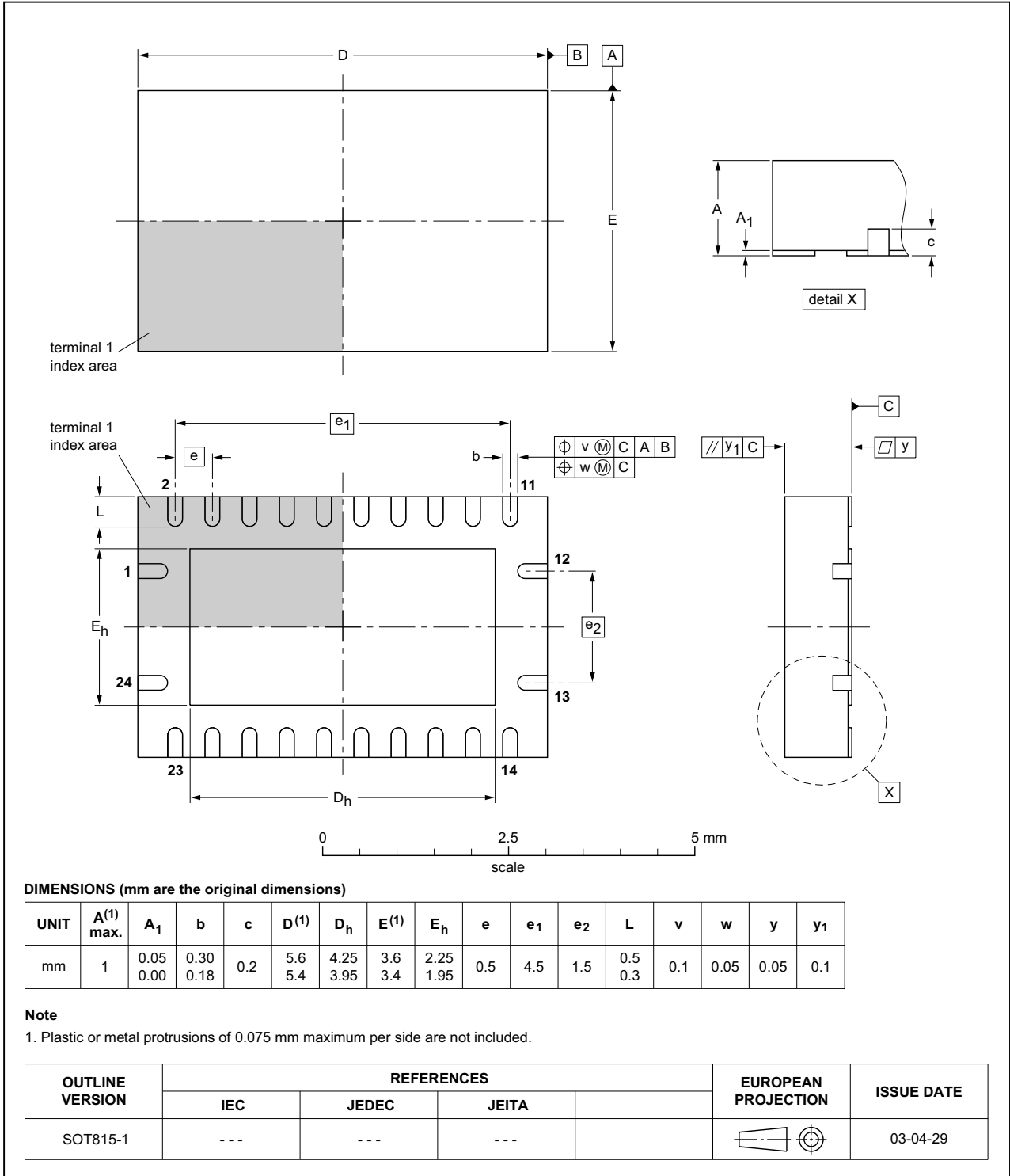

Fig 21. Package outline SOT815-1 (DHVQFN24)

## 13. Abbreviations

Table 12. Abbreviations

Acronym	Description
CDM	Charged Device Model
CMOS	Complementary Metal-Oxide Semiconductor
DUT	Device Under Test
ESD	ElectroStatic Discharge
HBM	Human Body Model
MM	Machine Model

## 14. Revision history

Table 13. Revision history

Document ID	Release date	Data sheet status	Change notice	Supersedes
74CBTLV3861 v.4	20161111	Product data sheet	-	74CBTLV3861 v.3
Modifications:	<ul style="list-style-type: none"> <li><a href="#">Section 11.1</a> and <a href="#">Section 11.2</a> added.</li> </ul>			
74CBTLV3861 v.3	20111216	Product data sheet	-	74CBTLV3861 v.2
Modifications:	<ul style="list-style-type: none"> <li>Legal pages updated.</li> </ul>			
74CBTLV3861 v.2	20110120	Product data sheet	-	74CBTLV3861 v.1
74CBTLV3861 v.1	20101206	Product data sheet	-	-

## 15. Legal information

### 15.1 Data sheet status

Document status <sup>[1][2]</sup>	Product status <sup>[3]</sup>	Definition
Objective [short] data sheet	Development	This document contains data from the objective specification for product development.
Preliminary [short] data sheet	Qualification	This document contains data from the preliminary specification.
Product [short] data sheet	Production	This document contains the product specification.

[1] Please consult the most recently issued document before initiating or completing a design.

[2] The term 'short data sheet' is explained in section "Definitions".

[3] The product status of device(s) described in this document may have changed since this document was published and may differ in case of multiple devices. The latest product status information is available on the Internet at URL <http://www.nxp.com>.

### 15.2 Definitions

**Draft** — The document is a draft version only. The content is still under internal review and subject to formal approval, which may result in modifications or additions. NXP Semiconductors does not give any representations or warranties as to the accuracy or completeness of information included herein and shall have no liability for the consequences of use of such information.

**Short data sheet** — A short data sheet is an extract from a full data sheet with the same product type number(s) and title. A short data sheet is intended for quick reference only and should not be relied upon to contain detailed and full information. For detailed and full information see the relevant full data sheet, which is available on request via the local NXP Semiconductors sales office. In case of any inconsistency or conflict with the short data sheet, the full data sheet shall prevail.

**Product specification** — The information and data provided in a Product data sheet shall define the specification of the product as agreed between NXP Semiconductors and its customer, unless NXP Semiconductors and customer have explicitly agreed otherwise in writing. In no event however, shall an agreement be valid in which the NXP Semiconductors product is deemed to offer functions and qualities beyond those described in the Product data sheet.

### 15.3 Disclaimers

**Limited warranty and liability** — Information in this document is believed to be accurate and reliable. However, NXP Semiconductors does not give any representations or warranties, expressed or implied, as to the accuracy or completeness of such information and shall have no liability for the consequences of use of such information. NXP Semiconductors takes no responsibility for the content in this document if provided by an information source outside of NXP Semiconductors.

In no event shall NXP Semiconductors be liable for any indirect, incidental, punitive, special or consequential damages (including - without limitation - lost profits, lost savings, business interruption, costs related to the removal or replacement of any products or rework charges) whether or not such damages are based on tort (including negligence), warranty, breach of contract or any other legal theory.

Notwithstanding any damages that customer might incur for any reason whatsoever, NXP Semiconductors' aggregate and cumulative liability towards customer for the products described herein shall be limited in accordance with the *Terms and conditions of commercial sale* of NXP Semiconductors.

**Right to make changes** — NXP Semiconductors reserves the right to make changes to information published in this document, including without limitation specifications and product descriptions, at any time and without notice. This document supersedes and replaces all information supplied prior to the publication hereof.

**Suitability for use** — NXP Semiconductors products are not designed, authorized or warranted to be suitable for use in life support, life-critical or safety-critical systems or equipment, nor in applications where failure or malfunction of an NXP Semiconductors product can reasonably be expected to result in personal injury, death or severe property or environmental damage. NXP Semiconductors and its suppliers accept no liability for inclusion and/or use of NXP Semiconductors products in such equipment or applications and therefore such inclusion and/or use is at the customer's own risk.

**Applications** — Applications that are described herein for any of these products are for illustrative purposes only. NXP Semiconductors makes no representation or warranty that such applications will be suitable for the specified use without further testing or modification.

Customers are responsible for the design and operation of their applications and products using NXP Semiconductors products, and NXP Semiconductors accepts no liability for any assistance with applications or customer product design. It is customer's sole responsibility to determine whether the NXP Semiconductors product is suitable and fit for the customer's applications and products planned, as well as for the planned application and use of customer's third party customer(s). Customers should provide appropriate design and operating safeguards to minimize the risks associated with their applications and products.

NXP Semiconductors does not accept any liability related to any default, damage, costs or problem which is based on any weakness or default in the customer's applications or products, or the application or use by customer's third party customer(s). Customer is responsible for doing all necessary testing for the customer's applications and products using NXP Semiconductors products in order to avoid a default of the applications and the products or of the application or use by customer's third party customer(s). NXP does not accept any liability in this respect.

**Limiting values** — Stress above one or more limiting values (as defined in the Absolute Maximum Ratings System of IEC 60134) will cause permanent damage to the device. Limiting values are stress ratings only and (proper) operation of the device at these or any other conditions above those given in the Recommended operating conditions section (if present) or the Characteristics sections of this document is not warranted. Constant or repeated exposure to limiting values will permanently and irreversibly affect the quality and reliability of the device.

**Terms and conditions of commercial sale** — NXP Semiconductors products are sold subject to the general terms and conditions of commercial sale, as published at <http://www.nxp.com/profile/terms>, unless otherwise agreed in a valid written individual agreement. In case an individual agreement is concluded only the terms and conditions of the respective agreement shall apply. NXP Semiconductors hereby expressly objects to applying the customer's general terms and conditions with regard to the purchase of NXP Semiconductors products by customer.

**No offer to sell or license** — Nothing in this document may be interpreted or construed as an offer to sell products that is open for acceptance or the grant, conveyance or implication of any license under any copyrights, patents or other industrial or intellectual property rights.

**Export control** — This document as well as the item(s) described herein may be subject to export control regulations. Export might require a prior authorization from competent authorities.

**Non-automotive qualified products** — Unless this data sheet expressly states that this specific NXP Semiconductors product is automotive qualified, the product is not suitable for automotive use. It is neither qualified nor tested in accordance with automotive testing or application requirements. NXP Semiconductors accepts no liability for inclusion and/or use of non-automotive qualified products in automotive equipment or applications.

In the event that customer uses the product for design-in and use in automotive applications to automotive specifications and standards, customer (a) shall use the product without NXP Semiconductors' warranty of the product for such automotive applications, use and specifications, and (b) whenever customer uses the product for automotive applications beyond

NXP Semiconductors' specifications such use shall be solely at customer's own risk, and (c) customer fully indemnifies NXP Semiconductors for any liability, damages or failed product claims resulting from customer design and use of the product for automotive applications beyond NXP Semiconductors' standard warranty and NXP Semiconductors' product specifications.

**Translations** — A non-English (translated) version of a document is for reference only. The English version shall prevail in case of any discrepancy between the translated and English versions.

## 15.4 Trademarks

Notice: All referenced brands, product names, service names and trademarks are the property of their respective owners.

## 16. Contact information

For more information, please visit: <http://www.nxp.com>

For sales office addresses, please send an email to: [salesaddresses@nxp.com](mailto:salesaddresses@nxp.com)

**17. Contents**

**1 General description . . . . . 1**

**2 Features and benefits . . . . . 1**

**3 Ordering information . . . . . 2**

**4 Functional diagram . . . . . 2**

**5 Pinning information . . . . . 3**

5.1 Pinning . . . . . 3

5.2 Pin description . . . . . 4

**6 Functional description . . . . . 4**

**7 Limiting values . . . . . 4**

**8 Recommended operating conditions . . . . . 5**

**9 Static characteristics . . . . . 5**

9.1 Test circuits . . . . . 6

9.2 ON resistance . . . . . 6

9.3 ON resistance test circuit and graphs . . . . . 7

**10 Dynamic characteristics . . . . . 9**

**11 Waveforms . . . . . 9**

**11.1 Additional dynamic characteristics . . . . . 12**

**11.2 Test circuit . . . . . 12**

**12 Package outline . . . . . 13**

**13 Abbreviations . . . . . 16**

**14 Revision history . . . . . 16**

**15 Legal information . . . . . 17**

15.1 Data sheet status . . . . . 17

15.2 Definitions . . . . . 17

15.3 Disclaimers . . . . . 17

15.4 Trademarks . . . . . 18

**16 Contact information . . . . . 18**

**17 Contents . . . . . 19**

Please be aware that important notices concerning this document and the product(s) described herein, have been included in section 'Legal information'.



© NXP Semiconductors N.V. 2016. All rights reserved.

For more information, please visit: <http://www.nxp.com>  
 For sales office addresses, please send an email to: [salesaddresses@nxp.com](mailto:salesaddresses@nxp.com)

Date of release: 11 November 2016  
 Document identifier: 74CBTLV3861

## Looking for pricing, stock, or lifecycle information?

Click below to explore more details on WIN SOURCE:

-  [View 74CBTLV3861DK,118 on WIN SOURCE](#)
-  [NXP / Nexperia Information](#)

## Optimize Your Supply Chain with WIN SOURCE Solutions

-  Global Sourcing Solution
-  Obsolete Management
-  Cost Control Management
-  Shortage Management
-  Alternative Solution
-  Excess Inventory Management