



**THE DATASHEET OF  
74CBTLV3257QG8**





# LOW-VOLTAGE QUAD 2:1MUX/DEMUX BUS SWITCH

74CBTLV3257

## FEATURES:

- Functionally equivalent to QS3257
- $5\Omega$  bi-directional switch connection between two ports
- Isolation under power-off conditions
- Over-voltage tolerant
- Latch-up performance exceeds 100mA
- $V_{CC} = 2.3V - 3.6V$ , Normal Range
- ESD > 2000V per MIL-STD-883, Method 3015;  
> 200V using machine model (C = 200pF, R = 0)
- Available in QSOP and TSSOP packages

## APPLICATIONS:

- 3.3V High Speed Bus Switching, Multiplexing, and Bus Isolation

## DESCRIPTION:

The CBTLV3257 is a quad 2:1 multiplexer/demultiplexer. The low on-state resistance of the switch allows connections to be made with minimal propagation delay.

The select (S) input controls the data flow. The multiplexers/demultiplexers are enabled when the output-enable ( $\overline{OE}$ ) input is low.

To ensure the high-impedance state during power up or power down,  $\overline{OE}$  should be tied to  $V_{CC}$  through a pullup resistor; the minimum value of the resistor is determined by the current-sinking capability of the driver.

## FUNCTIONAL BLOCK DIAGRAM

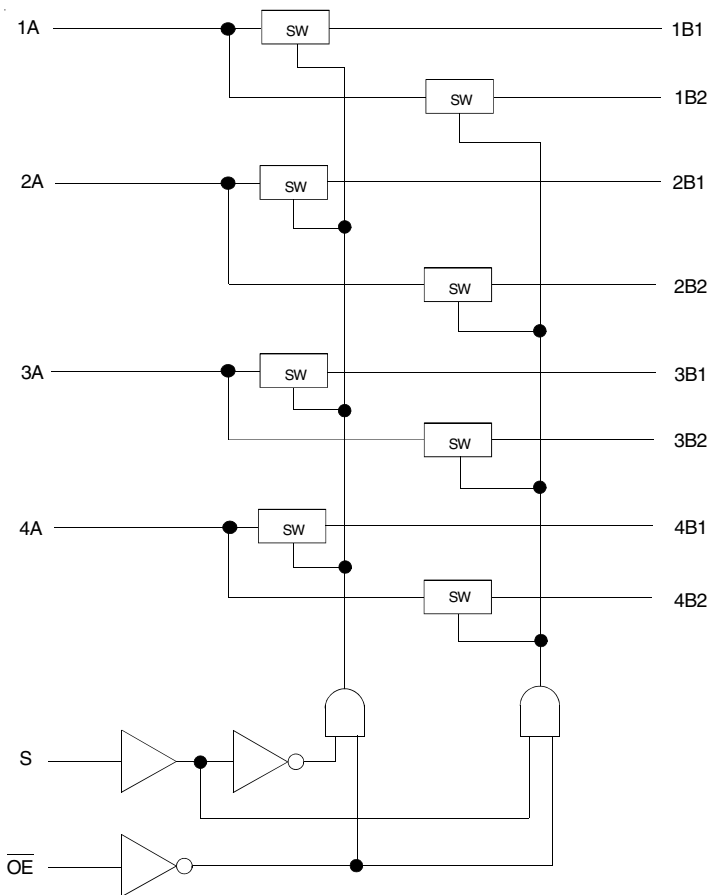

## SIMPLIFIED SCHEMATIC, EACH SWITCH

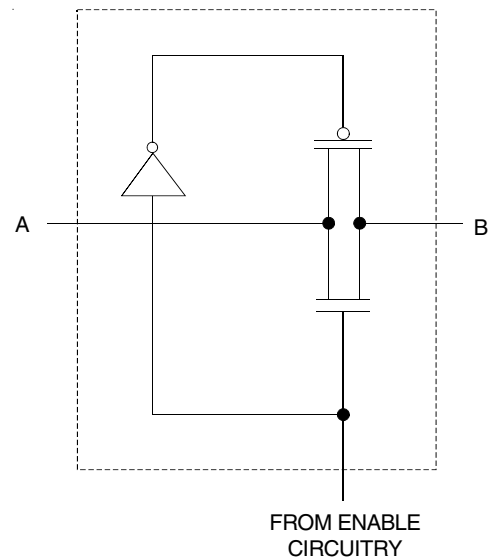

PIN CONFIGURATION

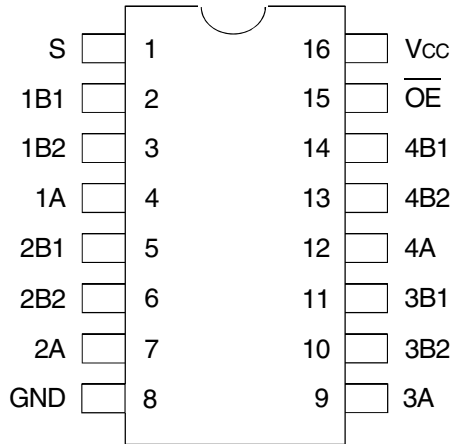

TOP VIEW

Package Type	Package Code	Order Code
TSSOP	PGG16	PGG
QSOP	PCG16	QG

ABSOLUTE MAXIMUM RATINGS<sup>(1)</sup>

Symbol	Description	Max	Unit
V <sub>CC</sub>	Supply Voltage Range	-0.5 to +4.6	V
V <sub>I</sub>	Input Voltage Range	-0.5 to +4.6	V
	Continuous Channel Current	128	mA
I <sub>IK</sub>	Input Clamp Current, V <sub>I/O</sub> < 0	-50	mA
T <sub>STG</sub>	Storage Temperature	-65 to +150	°C

NOTE:

1. Stresses greater than those listed under ABSOLUTE MAXIMUM RATINGS may cause permanent damage to the device. This is a stress rating only and functional operation of the device at these or any other conditions above those indicated in the operational sections of this specification is not implied. Exposure to absolute maximum rating conditions for extended periods may affect reliability.

FUNCTION TABLE<sup>(1)</sup>

Inputs		Function
OE	S	
L	L	A Port = B1 Port
L	H	A Port = B2 Port
H	X	Disconnect

NOTE:

1. H = HIGH Voltage Level  
L = LOW Voltage Level  
X = Don't Care

OPERATING CHARACTERISTICS, T<sub>A</sub> = 25°C<sup>(1)</sup>

Symbol	Parameter	Test Conditions	Min.	Max.	Unit
V <sub>CC</sub>	Supply Voltage		2.3	3.6	V
V <sub>IH</sub>	High-Level Control Input Voltage	V <sub>CC</sub> = 2.3V to 2.7V	1.7	—	V
		V <sub>CC</sub> = 2.7V to 3.6V	2	—	
V <sub>IL</sub>	Low-Level Control Input Voltage	V <sub>CC</sub> = 2.3V to 2.7V	—	0.7	V
		V <sub>CC</sub> = 2.7V to 3.6V	—	0.8	
T <sub>A</sub>	Operating Free-Air Temperature		-40	85	°C

NOTE:

1. All unused control inputs of the device must be held at V<sub>CC</sub> or GND to ensure proper device operation.

## DC ELECTRICAL CHARACTERISTICS OVER OPERATING RANGE

Following Conditions Apply Unless Otherwise Specified:

Operating Conditions:  $T_A = -40^{\circ}\text{C}$  to  $+85^{\circ}\text{C}$

Symbol	Parameter	Test Conditions	Min.	Typ. <sup>(1)</sup>	Max.	Unit	
$V_{IK}$	Control Inputs, Data Inputs	$V_{CC} = 3V$ , $I_I = -18\text{mA}$	—	—	-1.2	V	
$I_I$	Control Inputs	$V_{CC} = 3.6V$ , $V_I = V_{CC}$ or GND	—	—	$\pm 1$	$\mu\text{A}$	
$I_{OZ}$	Data I/O	$V_{CC} = 3.6V$ , $V_O = 0$ or $3.6V$ , switch disabled	—	—	20	$\mu\text{A}$	
$I_{OFF}$		$V_{CC} = 0$ , $V_I$ or $V_O = 0$ to $3.6V$	—	—	50	$\mu\text{A}$	
$I_{CC}$		$V_{CC} = 3.6V$ , $I_O = 0$ , $V_I = V_{CC}$ or GND	—	—	10	$\mu\text{A}$	
$\Delta I_{CC}^{(2)}$	Control Inputs	$V_{CC} = 3.6V$ , one input at $3V$ , other inputs at $V_{CC}$ or GND	—	—	300	$\mu\text{A}$	
$C_I$	Control Inputs	$V_I = 3V$ or $0$	—	4	—	pF	
$C_{IO(OFF)}$	A Port	$V_O = 3V$ or $0$ , $\overline{OE} = V_{CC} = 3.3V$	—	13	—	pF	
	B Port		—	6	—		
$R_{ON}^{(3)}$	$V_{CC} = 2.3V$ Typ. at $V_{CC} = 2.5V$	$V_I = 0$	$I_O = 64\text{mA}$	—	5	8	$\Omega$
			$I_O = 24\text{mA}$	—	5	8	
		$V_I = 1.7V$	$I_O = 15\text{mA}$	—	27	40	
	$V_{CC} = 3V$	$V_I = 0$	$I_O = 64\text{mA}$	—	5	7	
			$I_O = 24\text{mA}$	—	5	7	
		$V_I = 2.4V$	$I_O = 15\text{mA}$	—	10	15	

### NOTES:

- Typical values are at  $V_{CC} = 3.3V$ ,  $+25^{\circ}\text{C}$  ambient.
- The increase in supply current is attributable to each current that is at the specified voltage level rather than  $V_{CC}$  or GND.
- This is measured by the voltage drop between the A and B terminals at the indicated current through the switch. On-state resistance is determined by the lower of the voltages of the two (A or B) terminals.

## SWITCHING CHARACTERISTICS

Symbol	Parameter	$V_{CC} = 2.5V \pm 0.2V$		$V_{CC} = 3.3V \pm 0.3V$		Unit
		Min.	Max.	Min.	Max.	
$t_{PD}^{(1)}$	Propagation Delay A to B or B to A	—	0.15	—	0.25	ns
$t_{SEL}$	Select Time S to A or B	1	6.1	1	5.3	ns
$t_{EN}$	Enable Time S to B	1	6.1	1	5.3	ns
$t_{DIS}$	Disable Time S to B	1	4.8	1	4.5	ns
$t_{EN}$	Output Enable Time $\overline{OE}$ to A or B	1	5.6	1	5	ns
$t_{DIS}$	Output Disable Time $\overline{OE}$ to A or B	1	5.5	1	5.5	ns

### NOTE:

- The propagation delay is the calculated RC time constant of the typical on-state resistance of the switch and the specified load capacitance driven by an ideal voltage source (zero output impedance).

## TEST CIRCUITS AND WAVEFORMS

### TEST CONDITIONS

Symbol	$V_{CC}^{(1)} = 3.3V \pm 0.3V$	$V_{CC}^{(2)} = 2.5V \pm 0.2V$	Unit
$V_{LOAD}$	6	$2 \times V_{CC}$	V
$V_{IH}$	3	$V_{CC}$	V
$V_T$	1.5	$V_{CC} / 2$	V
$V_{LZ}$	300	150	mV
$V_{HZ}$	300	150	mV
$C_L$	50	30	pF

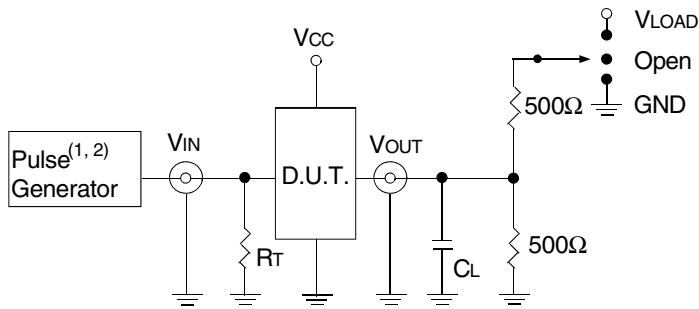

Test Circuits for All Outputs

#### DEFINITIONS:

$C_L$  = Load capacitance: includes jig and probe capacitance.  
 $R_T$  = Termination resistance: should be equal to  $Z_{OUT}$  of the Pulse Generator.

#### NOTES:

1. Pulse Generator for All Pulses: Rate  $\leq 10\text{MHz}$ ;  $t_r \leq 2.5\text{ns}$ ;  $t_f \leq 2.5\text{ns}$ .
2. Pulse Generator for All Pulses: Rate  $\leq 10\text{MHz}$ ;  $t_r \leq 2\text{ns}$ ;  $t_f \leq 2.5\text{ns}$ .

### SWITCH POSITION

Test	Switch
$t_{PLZ}/t_{PZL}$	$V_{LOAD}$
$t_{PHZ}/t_{PZH}$	GND
$t_{SEL}$	Open
$t_{PD}$	Open

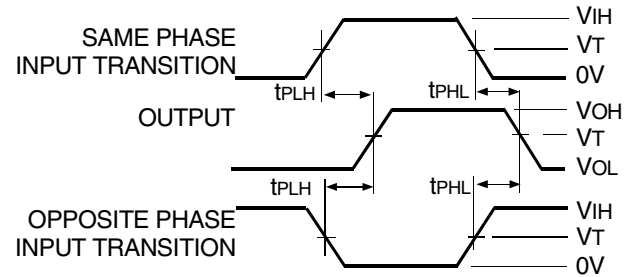

Propagation Delay

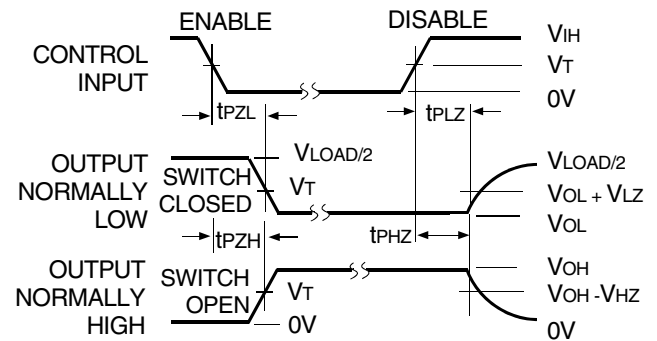

Enable and Disable Times

## ORDERING INFORMATION

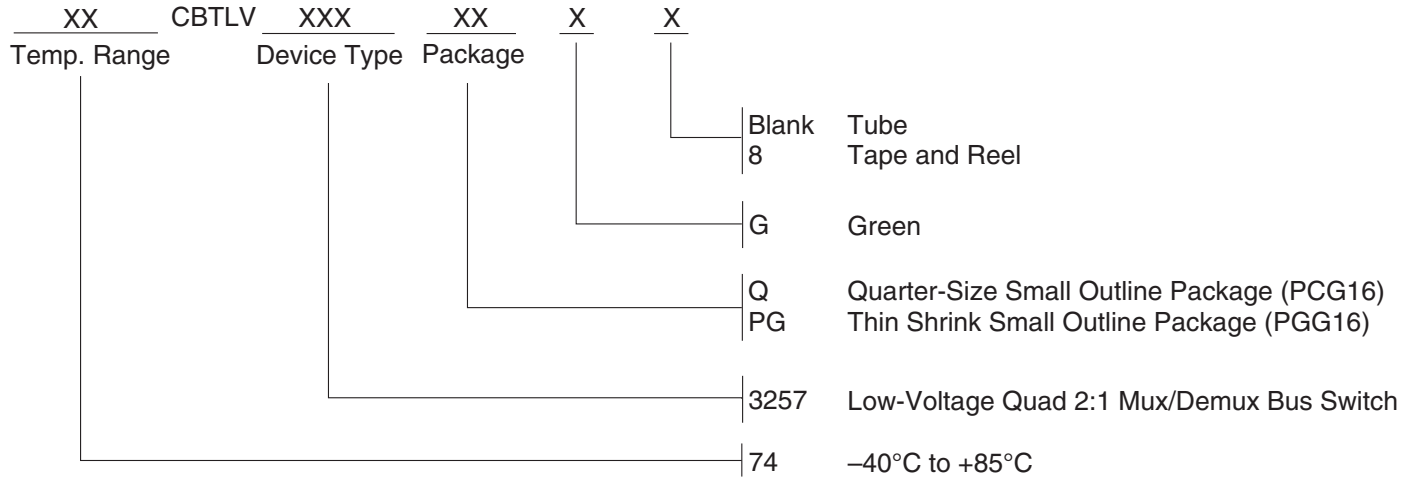

## Orderable Part Information

Speed (ns)	Orderable Part ID	Pkg. Code	Pkg. Type	Temp. Grade
	74CBTLV3257PGG	PGG16	TSSOP	I
	74CBTLV3257PGG8	PGG16	TSSOP	I
	74CBTLV3257QG	PCG16	QSOP	I
	74CBTLV3257QG8	PCG16	QSOP	I

## Datasheet Document History

12/18/2014	Pg. 5	Updated the ordering information by removing non RoHS part and by adding Tape and Reel information.
05/10/2019	Pg. 2,5	Added table under pin configuration diagram with detailed package information and orderable part information table. Updated the ordering information diagram in clearer detail.



**CORPORATE HEADQUARTERS**  
6024 Silver Creek Valley Road  
San Jose, CA 95138

**for SALES:**  
800-345-7015 or 408-284-8200  
fax: 408-284-2775  
www.idt.com

**for Tech Support:**  
logichelp@idt.com

## Looking for pricing, stock, or lifecycle information?

Click below to explore more details on WIN SOURCE:

- ⊖ [View 74CBTLV3257QG8 on WIN SOURCE](#)
- ⊖ [IDT, Integrated Device Technology Inc Information](#)

## Optimize Your Supply Chain with WIN SOURCE Solutions

- ✓ Global Sourcing Solution
- ✓ Obsolete Management
- ✓ Cost Control Management
- ✓ Shortage Management
- ✓ Alternative Solution
- ✓ Excess Inventory Management