



**THE DATASHEET OF
SKY13374-397LF**



DATA SHEET

SKY13374-397LF: 300 kHz to 6.0 GHz SPDT Switch

Applications

- Dual-band wireless LANs (802.11 a/b/g/n)
- Diversity antenna switching
- WCDMA handsets and data cards

Features

- Broadband frequency range: 300 kHz to 6.0 GHz
- Low insertion loss: 0.35 dB @ 1 GHz, 0.8 dB @ 6 GHz
- No external DC blocking capacitors required
- Positive low control voltage: 1.65 to 3.0 V (V_{CTRL}), 2.5 to 4.8 V (V_{BATT})
- Small, QFN (12-pin, 2 x 2 mm) package (MSL1, 260 °C per JEDEC J-STD-020)



Skyworks Green™ products are compliant with all applicable legislation and are halogen-free. For additional information, refer to *Skyworks Definition of Green™*, document number SQ04-0074.

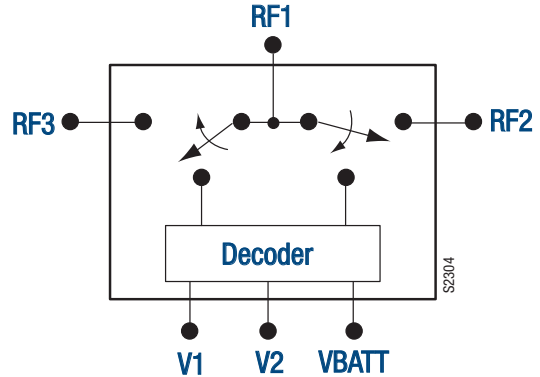

Figure 1. SKY13374-397LF Block Diagram

Description

The SKY13374-397LF is a CMOS silicon-on-insulator (SOI) single-pole, double-throw (SPDT) WCDMA band switch. The high-linearity performance and low insertion loss achieved by the device makes it an ideal choice for medium to high power WCDMA handset and data card applications.

The high 0.1 dB input compression point (IP0.1dB) and advance proprietary fabrication process enable exceptional WCDMA harmonic and adjacent channel power (ACP) performance. Excellent insertion loss and isolation is maintained over WCDMA bands 1 to 6 and 8 to 11.

The SKY13374-397LF SPDT switch is provided in a compact Quad Flat No-Lead (QFN) 2 x 2 mm package with 0.5 mm lead pitch for ease of manufacturing. A functional block diagram is shown in Figure 1. The pin configuration and package are shown in Figure 2. Signal pin assignments and functional pin descriptions are provided in Table 1.

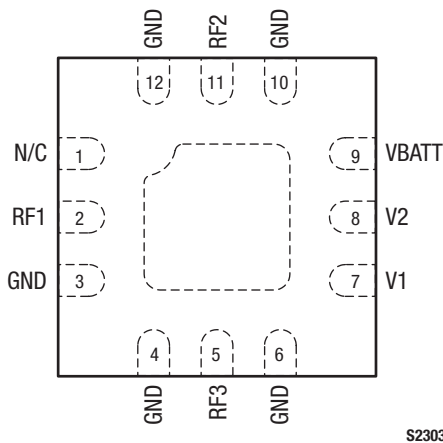

Figure 2. SKY13374-397LF Pinout (Top View)

Table 1. SKY13374-397LF Signal Descriptions (Note 1)

Pin	Name	Description	Pin	Name	Description
1	N/C	No connection	7	V1	DC control voltage. See Table 4.
2	RF1	RF port 1	8	V2	DC control voltage. See Table 4.
3	GND	Ground	9	VBATT	DC power supply.
4	GND	Ground	10	GND	Ground
5	RF3	RF port 3	11	RF2	RF port 2
6	GND	Ground	12	GND	Ground

Note 1: Exposed pad must be properly grounded using a low impedance path.

Functional Description

Switching is controlled by two control voltage inputs (V1 and V2). Depending on the logic voltage level applied to these pins, the RF1 pin is connected to one of two switched RF outputs (RF2 or RF3) using a low insertion loss path, while the path between the RF1 pin and the other RF path is in a high isolation state.

An internal negative voltage generator and decoder eliminate the need for external DC blocking capacitors on the RF ports. No external components are required for proper operation. DC decoupling capacitors may be added on the VBATT and control lines if necessary.

Shutdown mode is enabled by connecting both control pins (V1 and V2) to logic low. This mode reduces the overall current consumption of the device to 5 μ A typical.

Electrical and Mechanical Specifications

The absolute maximum ratings of the SKY13374-397LF are provided in Table 2. Electrical specifications are provided in Table 3.

The state of the SKY13374-397LF is determined by the logic provided in Table 4.

Typical performance characteristics of the SKY13374-397LF are illustrated in Figures 3 through 5.

Table 2. SKY13374-397LF Absolute Maximum Ratings (Note 1)

Parameter	Symbol	Minimum	Maximum	Units
Supply voltage	V _{BATT}	2.5	4.8	V
Control voltage	V _{CTL}	1.65	3.00	V
Input power	P _{IN}		+39	dBm
Storage temperature	T _{STG}	-40	+125	°C
Operating temperature	T _{OP}	-40	+85	°C

Note 1: Exposure to maximum rating conditions for extended periods may reduce device reliability. There is no damage to device with only one parameter set at the limit and all other parameters set at or below their nominal value. Exceeding any of the limits listed here may result in permanent damage to the device.

CAUTION: Although this device is designed to be as robust as possible, electrostatic discharge (ESD) can damage this device. This device must be protected at all times from ESD. Static charges may easily produce potentials of several kilovolts on the human body or equipment, which can discharge without detection. Industry-standard ESD precautions should be used at all times.

Table 3. SKY13374-397LF Electrical Specifications (Note 1)

(VBATT = 2.5 to 4.8 V, V1/V2 = 0/1.65 to 3.0 V, TOP = +25 °C, PIN = 0 dBm, Characteristic Impedance [Z0] = 50 Ω, Unless Otherwise Noted)

Parameter	Symbol	Test Condition	Min	Typical	Max	Units
RF Specifications						
Insertion loss	IL	RF1 to RF2/RF3:				
		300 kHz to 1.0 GHz		0.35	0.40	dB
		1.0 to 2.2 GHz		0.45	0.55	dB
		2.2 to 3.0 GHz		0.50	0.60	dB
		4.9 to 6.0 GHz		0.8	1.00	dB
Isolation	Iso	RF1 to RF2/RF3:				
		300 kHz to 2.2 GHz	30	34		dB
		2.2 to 3.0 GHz	25	28		dB
		4.9 to 6.0 GHz	18	22		dB
Shutdown isolation	ISO_SHUTDOWN			16		dB
Return loss	IS11I	RF1 to RF2/RF3, 300 kHz to 6.0 GHz		17		dB
0.1 dB input compression point	IPO.1dB	RF1 to RF2/RF3, 0.5 to 6.0 GHz		+39		dBm
Third order input intercept point	IIP3	0.8 to 3.0 GHz, Δf = 1 MHz, PIN = +26 dBm/tone		+68		dBm
Switching Speed Specifications						
Switching speed @ 2.45 GHz		50% VCTL to 90% RF		1200		ns
		50% VCTL to 10% RF		1200		ns
		10% RF to 90% RF rise		200		ns
		90% RF to 10% RF fall		150		ns
Startup time		Shutdown to any RF switch state		20		μs
DC Specifications						
Control voltage: High Low	V1, V2		1.65		3.00	V
			0		0.30	V
Supply voltage	VBATT		2.5		4.8	V
Supply current	IBATT	VBATT = 3 V		40		μA
Control current	ICTL	V1/V2 = 1.8 V		2		μA
Shutdown mode supply current	IOFF	V1/V2 = 0 V, VBATT = 1.8 V		5		μA

Note 1: Performance is guaranteed only under the conditions listed in this table.

Table 4. SKY13374-397LF Truth Table

V1	V2	State
0	0	Shutdown mode
1	0	RF1 to RF2
0	1	RF1 to RF3

Note: 1 = 1.65 to 3.0 V
0 = -0.1 to 0 V
Any state other than described in this table places the switch into an undefined state.

Typical Performance Characteristics

($V_{CTL} = 0\text{ V}$ and $+3.0\text{ V}$, $T_{OP} = +25\text{ }^{\circ}\text{C}$, $P_{IN} = 0\text{ dBm}$, Characteristic Impedance [Z_o] = $50\ \Omega$, Unless Otherwise Noted)

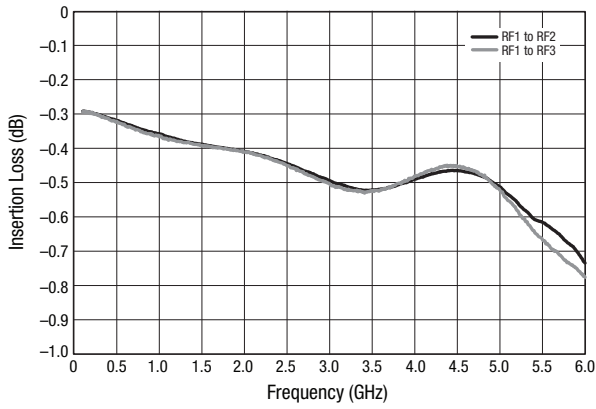

Figure 3. Typical Insertion Loss vs Frequency

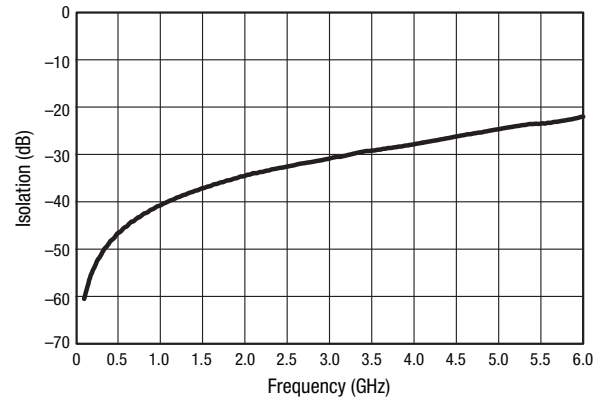

Figure 4. Typical Isolation vs Frequency (RF1 to RF2 Insertion Loss State)

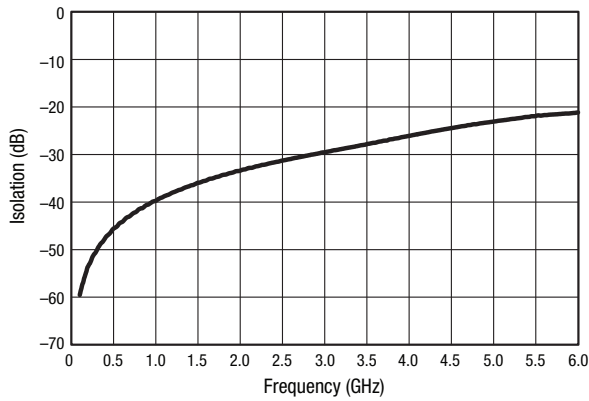

Figure 5. Typical Isolation vs Frequency (RF1 to RF3 Insertion Loss State)

Evaluation Board Description

The SKY13374-397LF Evaluation Board is used to test the performance of the SKY13374-397LF SPDT Switch.

An Evaluation Board schematic diagram is provided in Figure 6. An assembly drawing for the Evaluation Board is shown in Figure 7.

Package Dimensions

The PCB layout footprint for the SKY13374-397LF is provided in Figure 8. Typical part markings are shown in Figure 9. Package dimensions for the 12-pin QFN are shown in Figure 10, and tape and reel dimensions are provided in Figure 11.

Package and Handling Information

Instructions on the shipping container label regarding exposure to moisture after the container seal is broken must be followed. Otherwise, problems related to moisture absorption may occur when the part is subjected to high temperature during solder assembly.

The SKY13374-397LF is rated to Moisture Sensitivity Level 1 (MSL1) at 260 °C. It can be used for lead or lead-free soldering. For additional information, refer to the Skyworks Application Note, *Solder Reflow Information*, document number 200164.

Care must be taken when attaching this product, whether it is done manually or in a production solder reflow environment. Production quantities of this product are shipped in a standard tape and reel format.

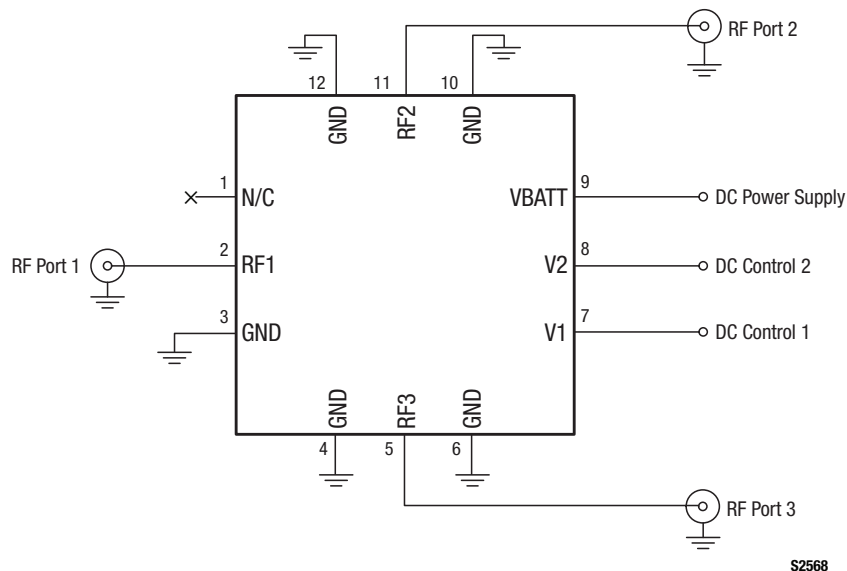

S2568

Figure 6. SKY13374-397LF Evaluation Board Schematic

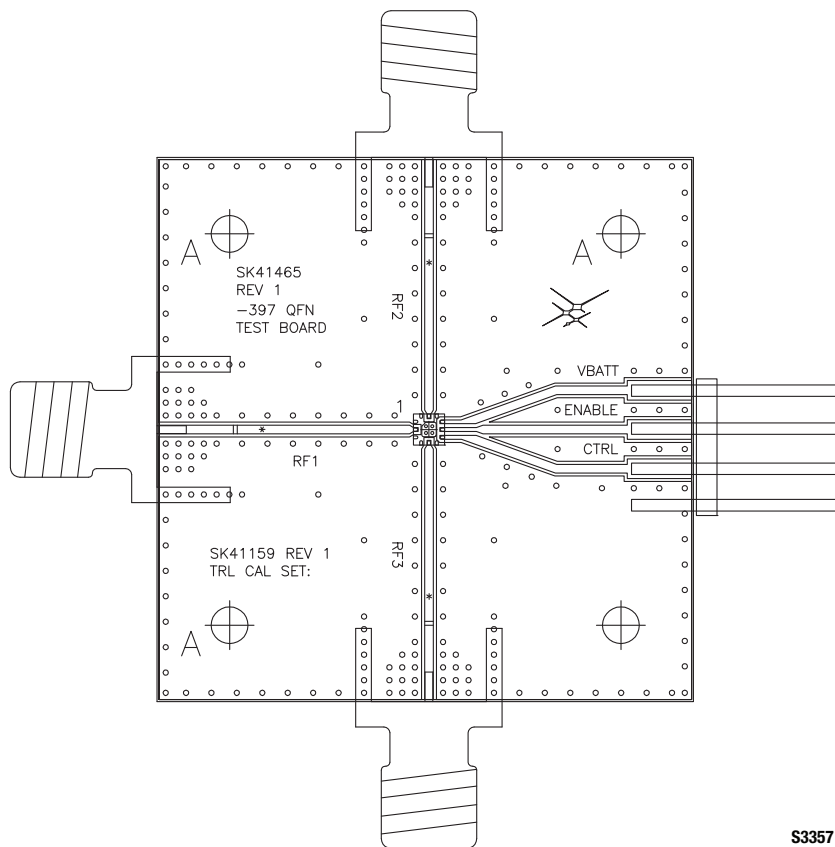

S3357

Figure 7. SKY13374-397LF Evaluation Board Assembly Diagram

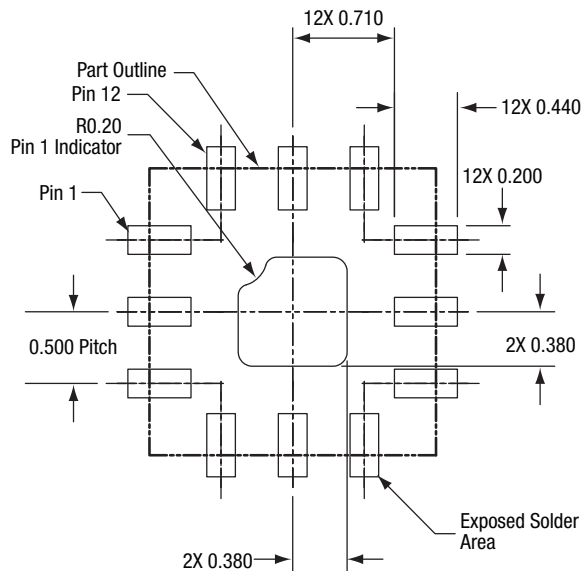

All measurements in millimeters

S3580

Figure 8. SKY13374-397LF PCB Layout Footprint (Top View)

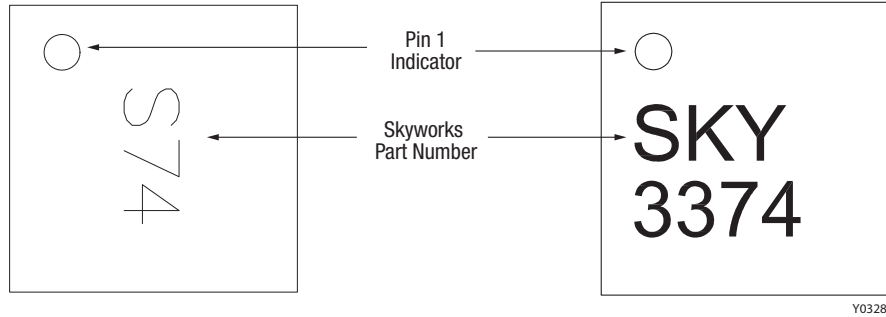
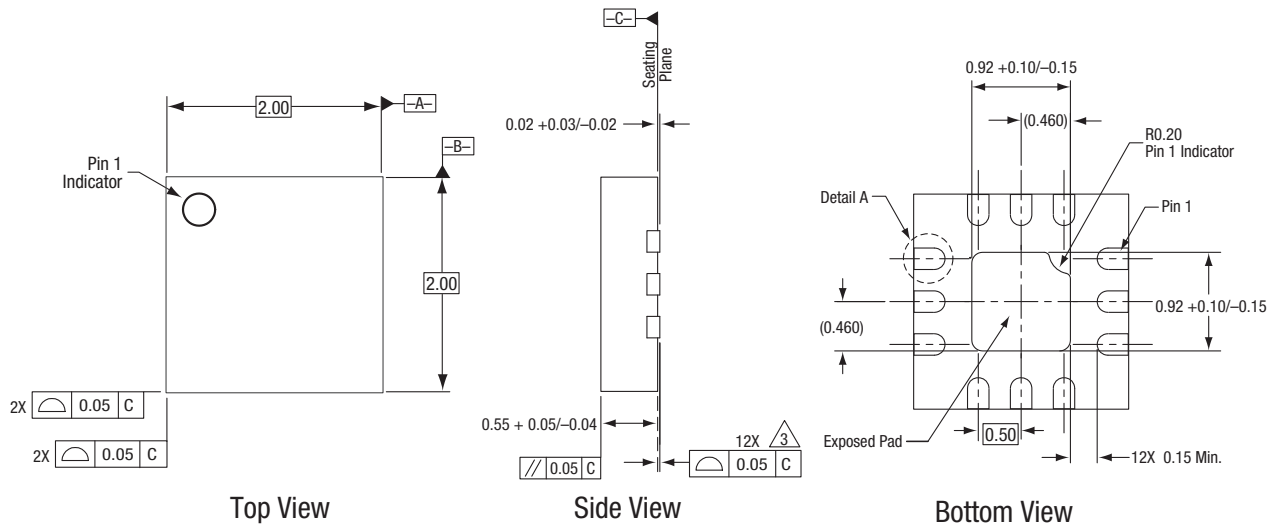

Figure 9. Typical Part Markings (Top View)



Notes:

1. All measurements are in millimeters.
2. Dimensions and tolerances according to ASME Y14.5M-1994.
3. Coplanarity applies to the terminals and all other bottom surface metallization.
4. Dimension applies to metallized terminal. If the terminal has a radius on its end, the width dimension should not be measured in that radius area.

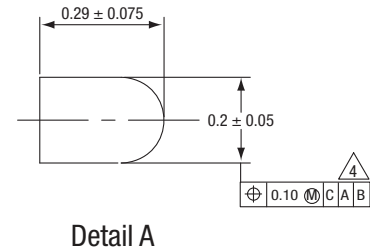
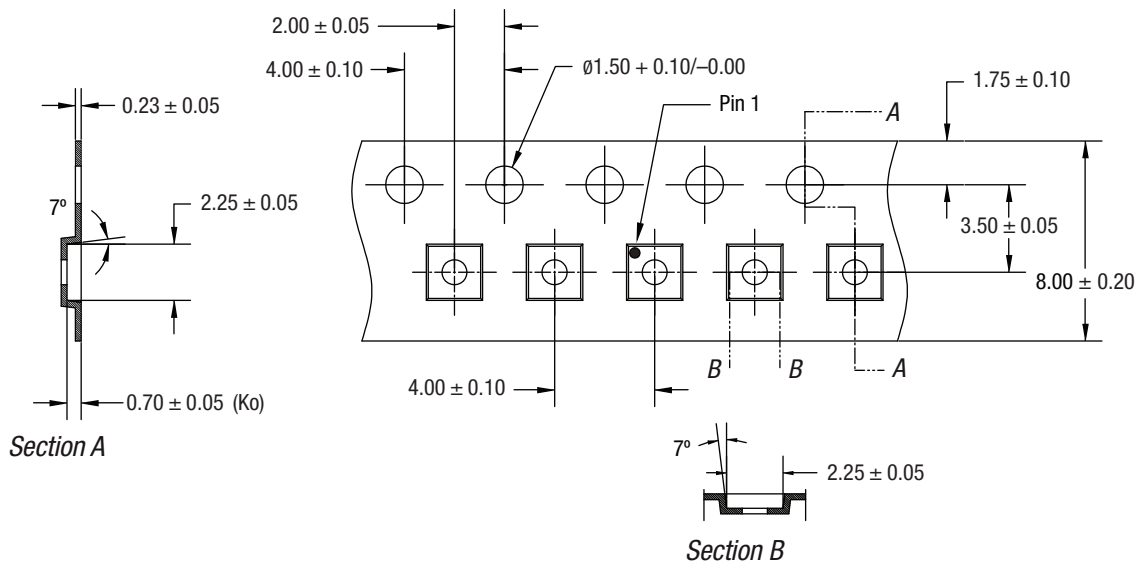

Figure 10. SKY13374-397LF Package Dimensions



Notes:

1. Carrier tape must meet all requirements of Skyworks GP01-D232 procurement spec for tape and reel shipping.
2. Carrier tape shall be black conductive polycarbonate bakeable material at 125 °C temperature.
3. Cover tape shall be transparent conductive with 5.40 mm width.
4. ESD-surface resistivity must meet all ESD requirements of Skyworks specified on GP01-D232.
5. All measurements are in millimeters.

ts737

Figure 11. SKY13374-397LF Tape and Reel Dimensions

Ordering Information

Model Name	Manufacturing Part Number	Evaluation Board Part Number
SKY13374-397LF SPDT Switch	SKY13374-397LF	SKY13374-397LF-EVB

Copyright © 2010-2013, 2015 Skyworks Solutions, Inc. All Rights Reserved.

Information in this document is provided in connection with Skyworks Solutions, Inc. ("Skyworks") products or services. These materials, including the information contained herein, are provided by Skyworks as a service to its customers and may be used for informational purposes only by the customer. Skyworks assumes no responsibility for errors or omissions in these materials or the information contained herein. Skyworks may change its documentation, products, services, specifications or product descriptions at any time, without notice. Skyworks makes no commitment to update the materials or information and shall have no responsibility whatsoever for conflicts, incompatibilities, or other difficulties arising from any future changes.

No license, whether express, implied, by estoppel or otherwise, is granted to any intellectual property rights by this document. Skyworks assumes no liability for any materials, products or information provided hereunder, including the sale, distribution, reproduction or use of Skyworks products, information or materials, except as may be provided in Skyworks Terms and Conditions of Sale.

THE MATERIALS, PRODUCTS AND INFORMATION ARE PROVIDED "AS IS" WITHOUT WARRANTY OF ANY KIND, WHETHER EXPRESS, IMPLIED, STATUTORY, OR OTHERWISE, INCLUDING FITNESS FOR A PARTICULAR PURPOSE OR USE, MERCHANTABILITY, PERFORMANCE, QUALITY OR NON-INFRINGEMENT OF ANY INTELLECTUAL PROPERTY RIGHT; ALL SUCH WARRANTIES ARE HEREBY EXPRESSLY DISCLAIMED. SKYWORKS DOES NOT WARRANT THE ACCURACY OR COMPLETENESS OF THE INFORMATION, TEXT, GRAPHICS OR OTHER ITEMS CONTAINED WITHIN THESE MATERIALS. SKYWORKS SHALL NOT BE LIABLE FOR ANY DAMAGES, INCLUDING BUT NOT LIMITED TO ANY SPECIAL, INDIRECT, INCIDENTAL, STATUTORY, OR CONSEQUENTIAL DAMAGES, INCLUDING WITHOUT LIMITATION, LOST REVENUES OR LOST PROFITS THAT MAY RESULT FROM THE USE OF THE MATERIALS OR INFORMATION, WHETHER OR NOT THE RECIPIENT OF MATERIALS HAS BEEN ADVISED OF THE POSSIBILITY OF SUCH DAMAGE.



Skyworks products are not intended for use in medical, lifesaving or life-sustaining applications, or other equipment in which the failure of the Skyworks products could lead to personal injury, death, physical or environmental damage. Skyworks customers using or selling Skyworks products for use in such applications do so at their own risk and agree to fully indemnify Skyworks for any damages resulting from such improper use or sale.

Customers are responsible for their products and applications using Skyworks products, which may deviate from published specifications as a result of design defects, errors, or operation of products outside of published parameters or design specifications. Customers should include design and operating safeguards to minimize these and other risks. Skyworks assumes no liability for applications assistance, customer product design, or damage to any equipment resulting from the use of Skyworks products outside of stated published specifications or parameters.

Skyworks and the Skyworks symbol are trademarks or registered trademarks of Skyworks Solutions, Inc., in the United States and other countries. Third-party brands and names are for identification purposes only, and are the property of their respective owners. Additional information, including relevant terms and conditions, posted at www.skyworksinc.com, are incorporated by reference.

Looking for pricing, stock, or lifecycle information?

Click below to explore more details on WIN SOURCE:

-  [View SKY13374-397LF on WIN SOURCE](#)
-  [Skyworks Solutions Inc. Information](#)

Optimize Your Supply Chain with WIN SOURCE Solutions

-  Global Sourcing Solution
-  Obsolete Management
-  Cost Control Management
-  Shortage Management
-  Alternative Solution
-  Excess Inventory Management