



**THE DATASHEET OF  
SKY13299-321LF**



**DATA SHEET**

# SKY13299-321LF: 20 MHz-5 GHz, 7 W SPDT Switch

**Applications**

- WiMAX and WLAN systems

**Features**

- Positive voltage operation: 0/3 to 0/5 V
- Low insertion loss: 0.5 dB typical @ 3.5 GHz
- High isolation >35 dB @ 3.5 GHz
- High P<sub>0.1dB</sub> of +38.5 dBm @ 3.3 V
- Low gate lag process for fast settling time applications
- Small, QFN (12-pin, 3 x 3 mm) package (MSL1, 260 °C per JEDEC J-STD-020)



Skyworks Green™ products are compliant with all applicable legislation and are halogen-free. For additional information, refer to *Skyworks Definition of Green™*, document number SQ04-0074.

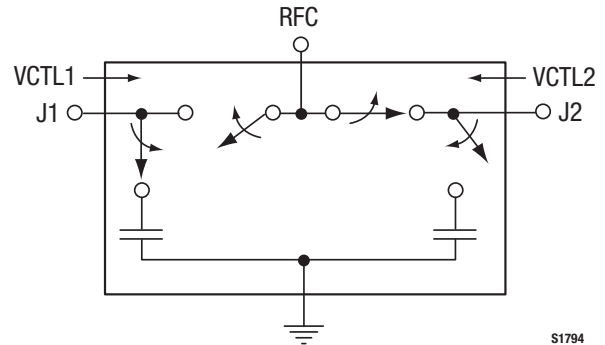

**Figure 1. SKY13299-321LF Block Diagram**

**Description**

The SKY13299-321LF is a high-power GaAs pHEMT FET I/C Single-Pole, Double-Throw (SPDT) switch. The device is provided in a 3 x 3 mm, 12-pin Quad Flat No-Lead (QFN) package.

The SKY13299-321LF is particularly suited for low-cost commercial WiMAX and WLAN applications where low insertion loss, high isolation, and excellent linearity are required.

A functional block diagram is shown in Figure 1. The pin configuration and package are shown in Figure 2. Signal pin assignments and functional pin descriptions are provided in Table 1.

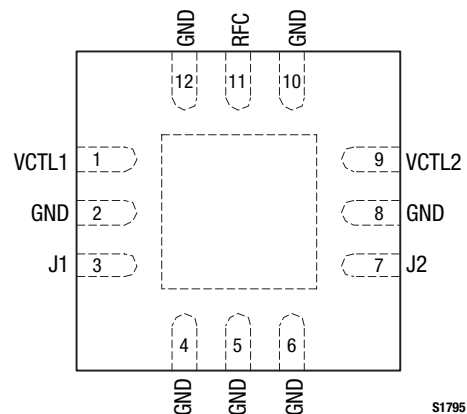

**Figure 2. SKY13299-321LF Pinout – 12-Pin QFN (Top View)**

**Table 1. SKY13299-321LF Signal Descriptions**

Pin #	Name	Description	Pin #	Name	Description
1	VCTL1	DC control voltage.	7	J2	RF port. Must be DC blocked.
2	GND	Ground	8	GND	Ground
3	J1	RF port. Must be DC blocked.	9	VCTL2	DC control voltage.
4	GND	Ground	10	GND	Ground
5	GND	Ground	11	RFC	RF common port. Must be DC blocked.
6	GND	Ground	12	GND	Ground

**Note:** Exposed pad must be grounded.

**Table 2. SKY13299-321LF Absolute Maximum Ratings (Note 1)**

Parameter	Symbol	Minimum	Maximum	Units
Control voltage range	V <sub>CTL</sub>	2.75	7	V
RF input power @ 3.3 V, @ 25 °C (f > 700 MHz) (Note 2)	P <sub>IN</sub>		+39.5	dBm
RF input power @ 5.0 V, @ 25 °C (f > 700 MHz) (Note 2)	P <sub>IN</sub>		+40.0	dBm
Operating temperature	T <sub>OP</sub>	-40	+85	°C
Storage temperature	T <sub>STG</sub>	-65	+150	°C

**Note 1:** Exposure to maximum rating conditions for extended periods may reduce device reliability. There is no damage to device with only one parameter set at the limit and all other parameters set at or below their nominal value. Exceeding any of the limits listed here may result in permanent damage to the device.

**Note 2:** Input power under matched conditions (50 Ω). Defined as peak or CW. For high Peak-to-Average Ratio (PAR) signals, the highest peak should be below the maximum value shown here.

---

**CAUTION:** Although this device is designed to be as robust as possible, Electrostatic Discharge (ESD) can damage this device. This device must be protected at all times from ESD. Static charges may easily produce potentials of several kilovolts on the human body or equipment, which can discharge without detection. Industry-standard ESD precautions should be used at all times.

---

## Electrical and Mechanical Specifications

The absolute maximum ratings of the SKY13299-321LF are provided in Table 2. Electrical specifications are provided in Table 3.

The state of the SKY13299-321LF is determined by the logic provided in Table 4.

Typical performance characteristics are illustrated in Figures 3 to 8.

**Table 3. SKY13299-321LF Electrical Specifications (Note 1)****( $V_{CTL} = 0$  to 3 V,  $T_{OP} = +25$  °C,  $P_{IN} = 0$  dBm, Characteristic Impedance [ $Z_0$ ] = 50  $\Omega$ , , Unless Otherwise Noted)**

Parameter	Symbol	Test Condition	Min	Typical	Max	Units
Insertion loss	IL	0.02 to 1.0 GHz		0.30	0.50	dB
		1.0 to 2.0 GHz		0.40	0.60	dB
		2.0 to 3.0 GHz		0.45	0.65	dB
		3.0 to 4.0 GHz		0.65	0.85	dB
		4.0 to 5.0 GHz		0.75	1.00	dB
Isolation	Iso	0.02 to 1.0 GHz	26	29		dB
		1.0 to 2.0 GHz	26	29		dB
		2.0 to 3.0 GHz	26	29		dB
		3.0 to 4.0 GHz	27	30		dB
		4.0 to 5.0 GHz	19	22		dB
Return loss (insertion loss state) (Note 2)		0.02 to 1.0 GHz		20		dB
		1.0 to 2.0 GHz		17		dB
		2.0 to 3.0 GHz		20		dB
		3.0 to 4.0 GHz		17		dB
		4.0 to 5.0 GHz		17		dB
Switching characteristics: Rise/fall time		10/90% or 90/10% RF		200		ns
		On/off time		300		ns
Settling time		50% $V_{CTL}$ to 0.1 dB final value		2		$\mu$ s
Harmonics	H2, H3	$P_{IN} = +34$ dBm, CW, @ 900 MHz		-80		dBc
		$P_{IN} = +31$ dBm, CW, @ 5000 MHz		-78		dBc
0.1 dB Input Compression Point	IPO.1dB	0.7 to 4.0 GHz 48 MHz		+38.5 +38.5		dBm dBm
3 <sup>rd</sup> Order Input Intercept Point	IIP3	$V_{CTL} = 3$ V				
		For two-tone input power, +27 dBm/tone, 900 and 901 MHz		+65		dBm
		For two-tone input power, +27 dBm/tone, 2400 and 2401 MHz		+66		dBm
		For two-tone input power, +27 dBm/tone, 3500 and 3501 MHz		+61		dBm
		For two-tone input power, +27 dBm/tone, 5000 and 5001 MHz		+57		dBm
Control voltage	$V_{DD}$	$V_{CTL} = \text{low}$	0		0.2	V
		$V_{CTL} = \text{high}$	2.75		5.00	V
Supply current	$I_{DD}$	$V_{CTL} = \text{low}$		5		$\mu$ A
		$V_{CTL} = \text{high}$ @ 3.3 V and <+30 dBm input		50		$\mu$ A
		$V_{CTL} = \text{high}$ @ 3.3 V and +30 to +37 dBm input		100		$\mu$ A
		$V_{CTL} = \text{high}$ @ 3.3 V and +37 to +38 dBm input		200		$\mu$ A

**Note 1:** Performance is guaranteed only under the conditions listed in this Table.**Note 2:** Lower frequency return loss is dependent on DC blocks.

**Table 4. SKY13299-321LF Truth Table**

VCTL1	VCTL2	RFC to J1	RFC to J2
1	0	Insertion loss	Isolation
0	1	Isolation	Insertion loss

**Note:** 1 = +2.75 to +5.00 V  
 low = 0 to 0.2 V  
 Any state other than described in this Table places the switch into an undefined state.

**Typical Performance Characteristics**

(VCTL = 0 to 3 V, TOP = +25 °C, PIN = 0 dBm, Characteristic Impedance [Zo] = 50 Ω, , Unless Otherwise Noted)

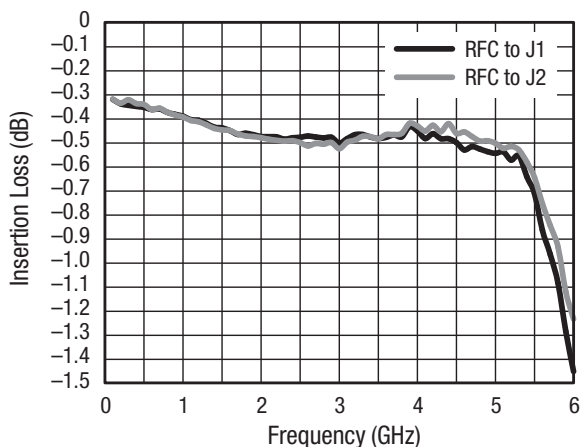

**Figure 3. Typical Insertion Loss**

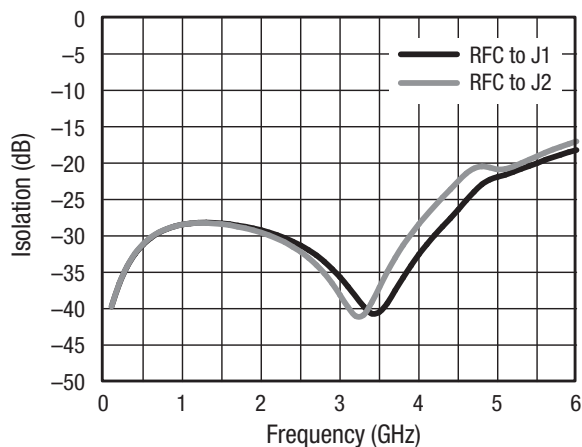

**Figure 4. Typical Isolation**

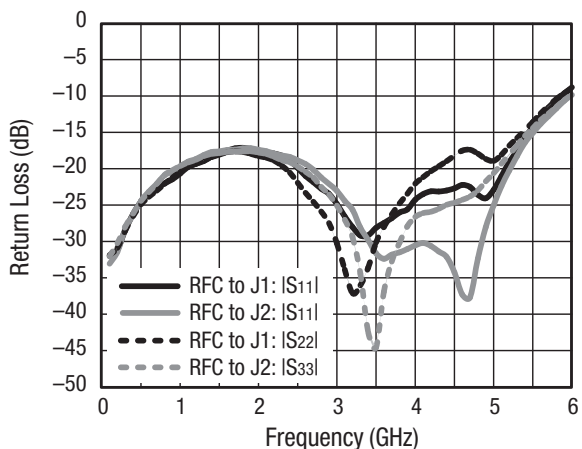

**Figure 5. Typical Return Loss**

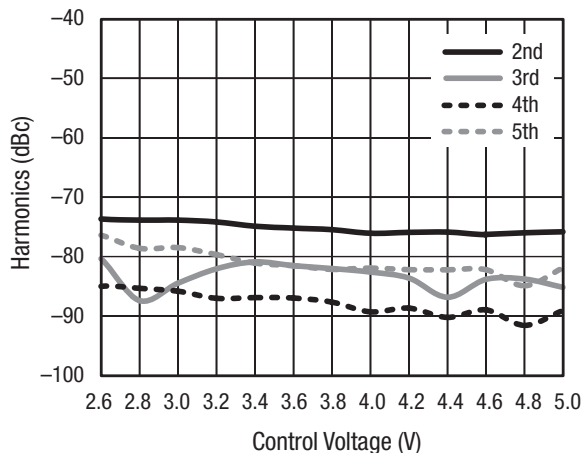

**Figure 6. Typical Harmonics**  
 (f = 900 MHz, PIN = +34 dBm, CW)

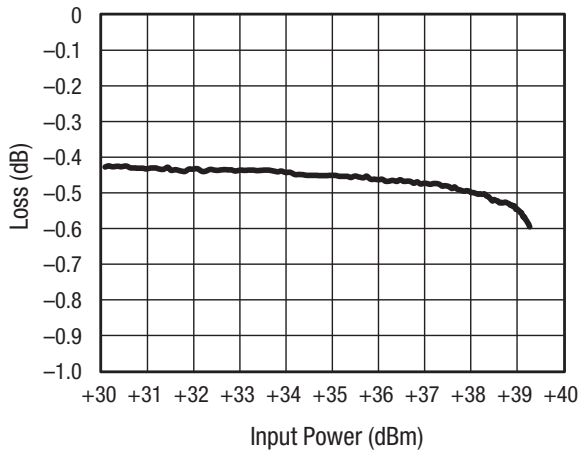

**Figure 7. Typical Loss vs Input Power**  
(f = 2500 MHz, V<sub>CTL</sub> = 3.3 V)

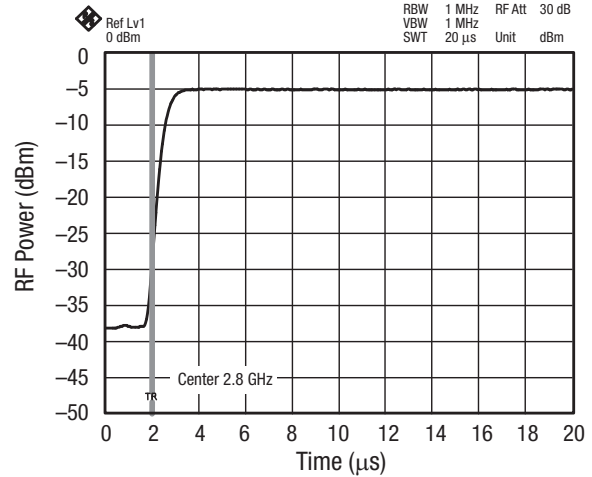

**Figure 8. Typical Settling Time**

### Evaluation Board Description

The SKY13299-321LF Evaluation Board is used to test the performance of the SKY13299-321LF SPDT switch. An assembly drawing for the Evaluation Board is shown in Figure 9 and an Evaluation Board schematic diagram is shown in Figure 10.

### Package Dimensions

The PCB layout footprint for the SKY13299-321LF is shown in Figure 11. Typical case markings are noted in Figure 12. Package dimensions for the 12-pin QFN are shown in Figure 13, and tape and reel dimensions are provided in Figure 14.

### Package and Handling Information

Instructions on the shipping container label regarding exposure to moisture after the container seal is broken must be followed. Otherwise, problems related to moisture absorption may occur when the part is subjected to high temperature during solder assembly.

THE SKY13299-321LF is rated to Moisture Sensitivity Level 1 (MSL1) at 260 °C. It can be used for lead or lead-free soldering. For additional information, refer to the Skyworks Application Note, *Solder Reflow Information*, document number 200164.

Care must be taken when attaching this product, whether it is done manually or in a production solder reflow environment. Production quantities of this product are shipped in a standard tape and reel format.

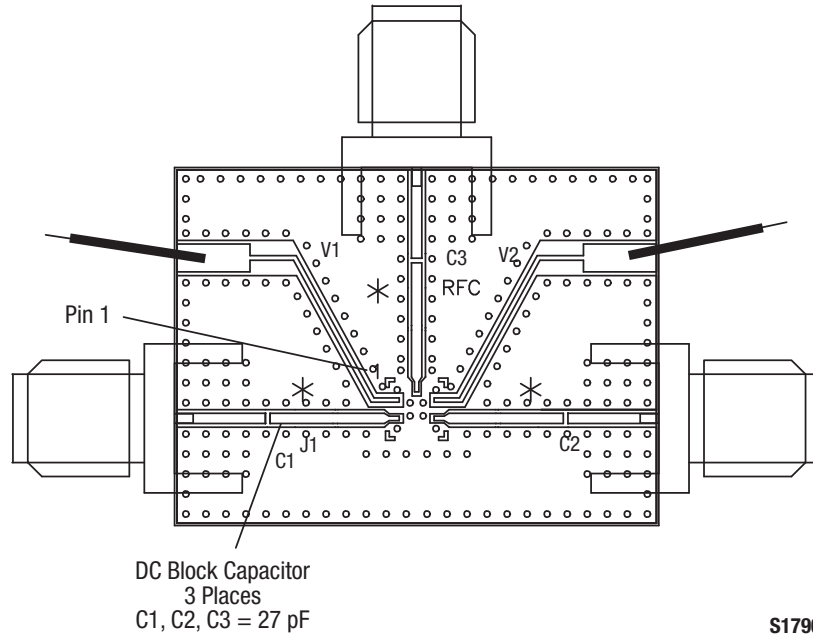

S1796

Figure 9. SKY13299-321LF Evaluation Board Assembly Diagram

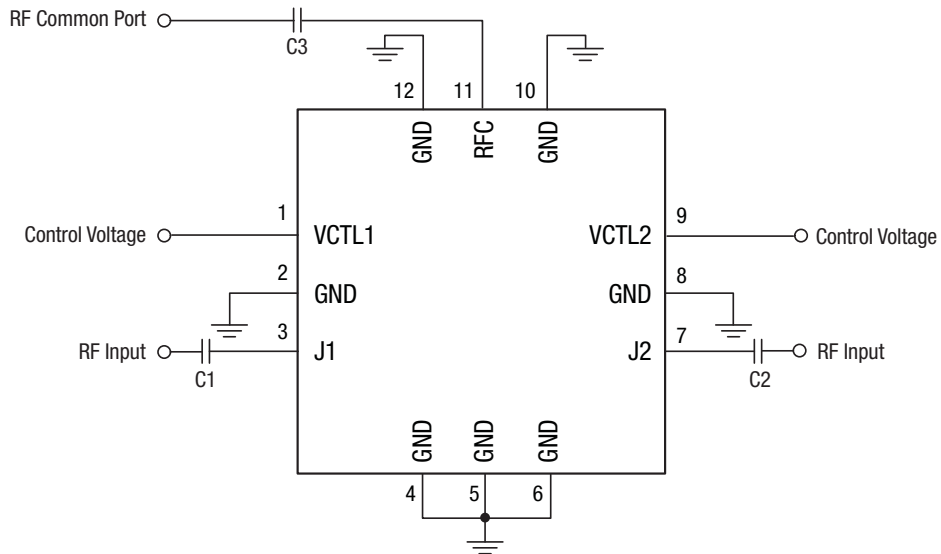

S1798

Figure 10. SKY13299-321LF Evaluation Board Schematic Diagram

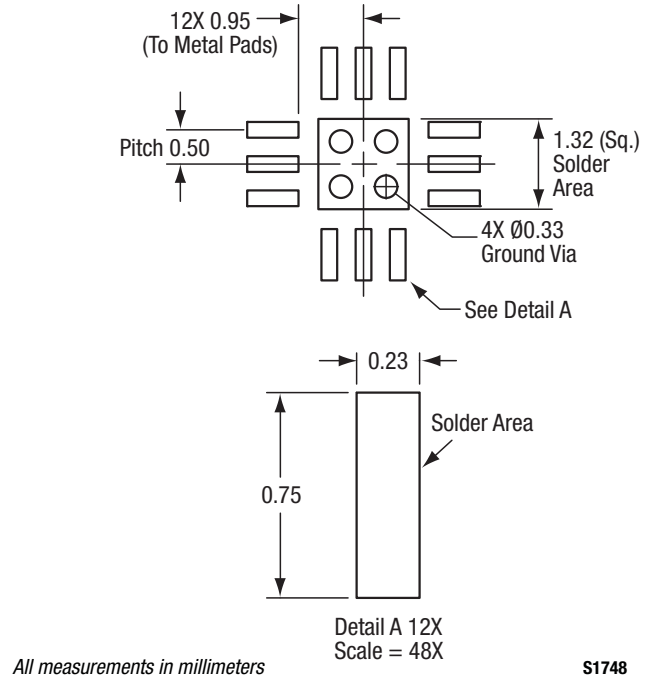

**Figure 11. SKY13299-321LF PCB Layout Footprint**

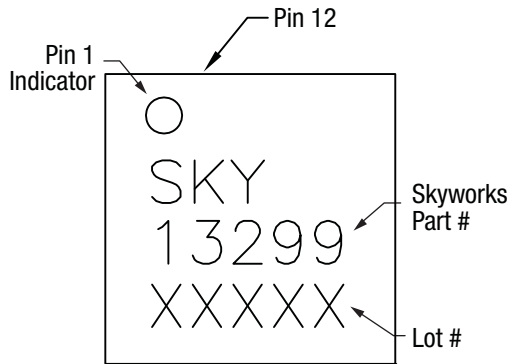

**Figure 12. Typical Part Markings (Top View)**

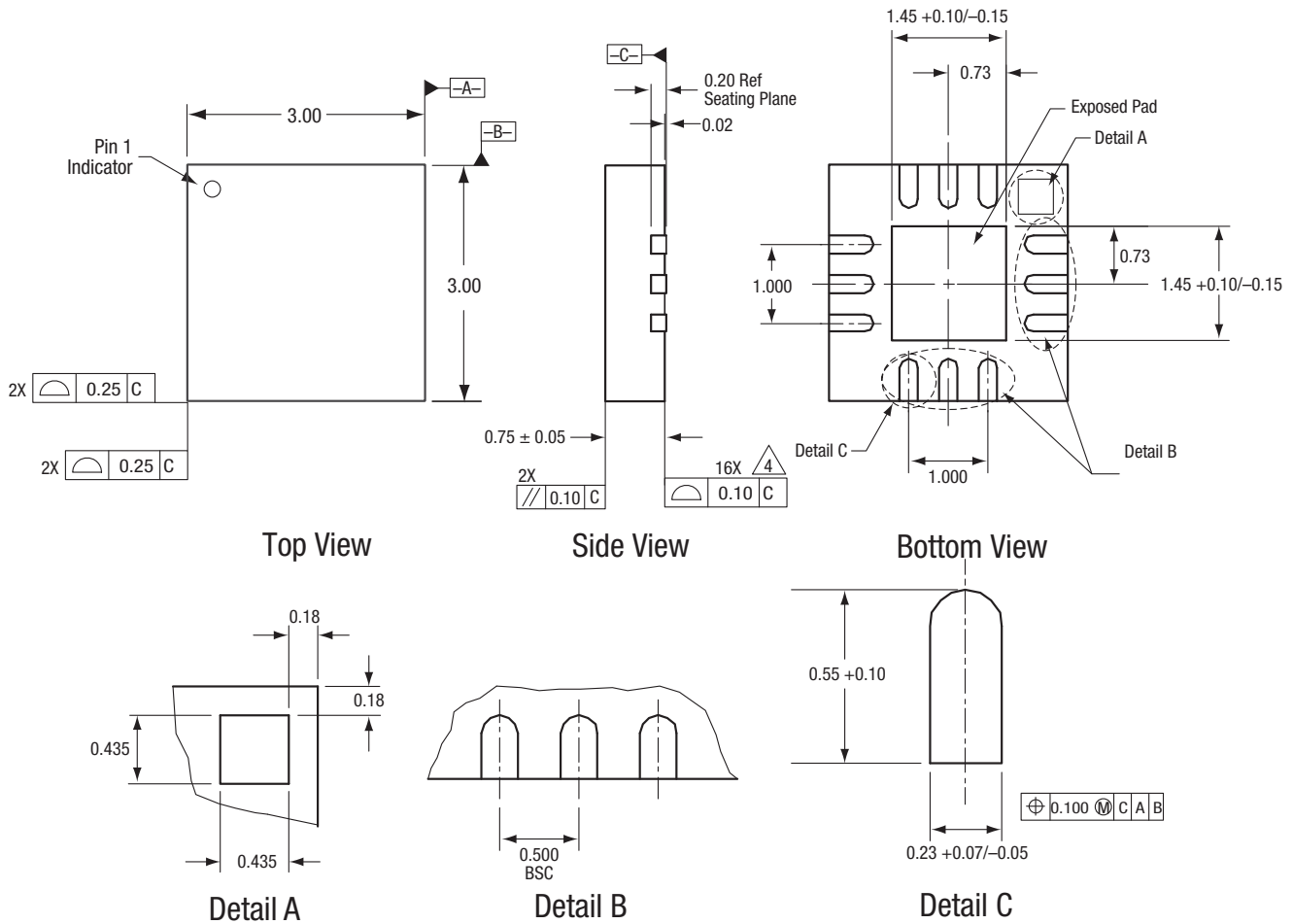

All measurements are in millimeters.  
 Dimensioning and tolerancing according to ASME Y14.5M-1994.  
 Coplanarity applies to the exposed heat sink slug as well as the terminals.  
 Plating requirement per source control drawing (SCD) 2504.  
 All contact points are pure matte tin, Pb-free surfaces.

S1542

Figure 13. SKY13299-321LF 12-Pin QFN Package Dimensions

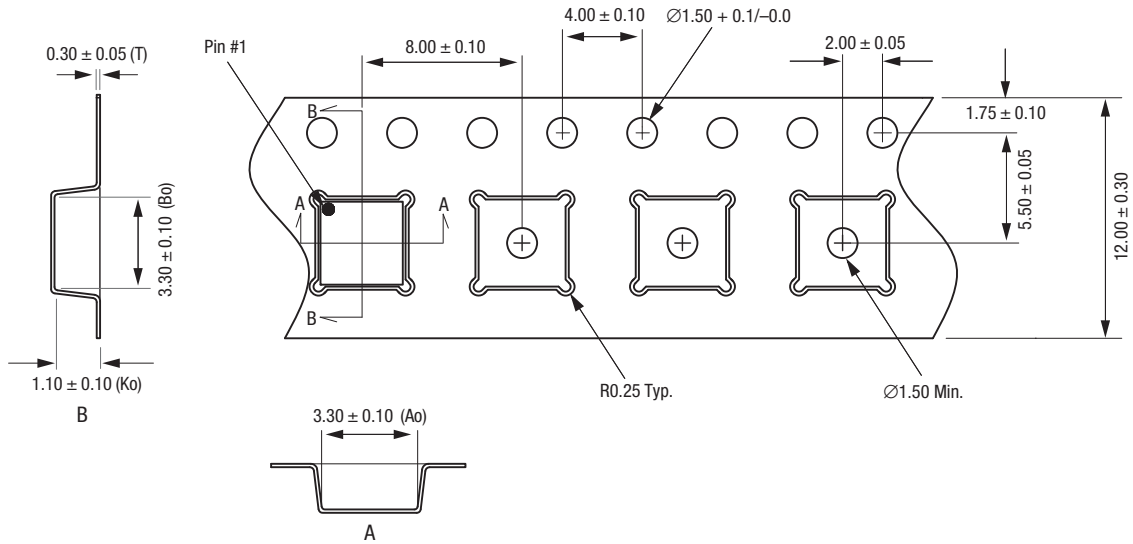

- Notes:
1. Carrier tape: black conductive polystyrene, non-bakeable material.
  2. Cover tape material: transparent conductive HSA.
  3. Cover tape size: 9.20 mm width.
  4. All measurements are in millimeters.

S1698

Figure 14. SKY13299-321LF Tape and Reel Dimensions

## Ordering Information

Model Name	Manufacturing Part Number	Evaluation Board Part Numbers
SKY13299-321LF SPDT Switch	SKY13299-321LF	SKY13299-321LF-EVB

Copyright © 2003-2007, 2009- 2011, 2013 Skyworks Solutions, Inc. All Rights Reserved.

Information in this document is provided in connection with Skyworks Solutions, Inc. ("Skyworks") products or services. These materials, including the information contained herein, are provided by Skyworks as a service to its customers and may be used for informational purposes only by the customer. Skyworks assumes no responsibility for errors or omissions in these materials or the information contained herein. Skyworks may change its documentation, products, services, specifications or product descriptions at any time, without notice. Skyworks makes no commitment to update the materials or information and shall have no responsibility whatsoever for conflicts, incompatibilities, or other difficulties arising from any future changes.

No license, whether express, implied, by estoppel or otherwise, is granted to any intellectual property rights by this document. Skyworks assumes no liability for any materials, products or information provided hereunder, including the sale, distribution, reproduction or use of Skyworks products, information or materials, except as may be provided in Skyworks Terms and Conditions of Sale.

THE MATERIALS, PRODUCTS AND INFORMATION ARE PROVIDED "AS IS" WITHOUT WARRANTY OF ANY KIND, WHETHER EXPRESS, IMPLIED, STATUTORY, OR OTHERWISE, INCLUDING FITNESS FOR A PARTICULAR PURPOSE OR USE, MERCHANTABILITY, PERFORMANCE, QUALITY OR NON-INFRINGEMENT OF ANY INTELLECTUAL PROPERTY RIGHT; ALL SUCH WARRANTIES ARE HEREBY EXPRESSLY DISCLAIMED. SKYWORKS DOES NOT WARRANT THE ACCURACY OR COMPLETENESS OF THE INFORMATION, TEXT, GRAPHICS OR OTHER ITEMS CONTAINED WITHIN THESE MATERIALS. SKYWORKS SHALL NOT BE LIABLE FOR ANY DAMAGES, INCLUDING BUT NOT LIMITED TO ANY SPECIAL, INDIRECT, INCIDENTAL, STATUTORY, OR CONSEQUENTIAL DAMAGES, INCLUDING WITHOUT LIMITATION, LOST REVENUES OR LOST PROFITS THAT MAY RESULT FROM THE USE OF THE MATERIALS OR INFORMATION, WHETHER OR NOT THE RECIPIENT OF MATERIALS HAS BEEN ADVISED OF THE POSSIBILITY OF SUCH DAMAGE.

Skyworks products are not intended for use in medical, lifesaving or life-sustaining applications, or other equipment in which the failure of the Skyworks products could lead to personal injury, death, physical or environmental damage. Skyworks customers using or selling Skyworks products for use in such applications do so at their own risk and agree to fully indemnify Skyworks for any damages resulting from such improper use or sale.

Customers are responsible for their products and applications using Skyworks products, which may deviate from published specifications as a result of design defects, errors, or operation of products outside of published parameters or design specifications. Customers should include design and operating safeguards to minimize these and other risks. Skyworks assumes no liability for applications assistance, customer product design, or damage to any equipment resulting from the use of Skyworks products outside of stated published specifications or parameters.

Skyworks, the Skyworks symbol, and "Breakthrough Simplicity" are trademarks or registered trademarks of Skyworks Solutions, Inc., in the United States and other countries. Third-party brands and names are for identification purposes only, and are the property of their respective owners. Additional information, including relevant terms and conditions, posted at [www.skyworksinc.com](http://www.skyworksinc.com), are incorporated by reference.

## Looking for pricing, stock, or lifecycle information?

Click below to explore more details on WIN SOURCE:

-  [View SKY13299-321LF on WIN SOURCE](#)
-  [Skyworks Solutions Inc. Information](#)

## Optimize Your Supply Chain with WIN SOURCE Solutions

-  Global Sourcing Solution
-  Obsolete Management
-  Cost Control Management
-  Shortage Management
-  Alternative Solution
-  Excess Inventory Management