



**THE DATASHEET OF
74AVCB324245ZKER**



FEATURES

- Member of the Texas Instruments Widebus+™ Family
- DOC™ Circuitry Dynamically Changes Output Impedance, Resulting in Noise Reduction Without Speed Degradation
- Dynamic Drive Capability Is Equivalent to Standard Outputs With I_{OH} and I_{OL} of
 - ± 24 mA at 3-V V_{CC}
 - ± 15 mA at 2.3-V V_{CC}
 - ± 9 mA at 1.65-V V_{CC}
 - ± 6 mA at 1.4-V V_{CC}
- Control Inputs V_{IH}/V_{IL} Levels Are Referenced to V_{CCB} Voltage
- If Either V_{CC} Input Is at GND, Both Ports Are in the High-Impedance State
- Inputs/Outputs Can Tolerate up to 4.6 V, Which Allows Mixed-Voltage-Mode Data Communications
- I_{off} Supports Partial-Power-Down Mode Operation
- Fully Configurable Dual-Rail Design Allows Each Port to Operate Over the Full 1.4-V to 3.6-V Power-Supply Range
- Latch-Up Performance Exceeds 100 mA Per JESD 78, Class II
- ESD Protection Exceeds JESD 22
 - 2000-V Human-Body Model (A114-A)
 - 200-V Machine Model (A115-A)
 - 1000-V Charged-Device Model (C101)

DESCRIPTION/ORDERING INFORMATION

This 32-bit noninverting bus transceiver uses two separate configurable power-supply rails. The A port is designed to track V_{CCA} . V_{CCA} accepts any supply voltage from 1.4 V to 3.6 V. The B port is designed to track V_{CCB} . V_{CCB} accepts any supply voltage from 1.4 V to 3.6 V. This allows for universal low-voltage bidirectional translation between any of the 1.5-V, 1.8-V, 2.5-V, and 3.3-V voltage nodes.

The SN74AVCB324245 is designed for asynchronous communication between data buses. The device transmits data from the A bus to the B bus or from the B bus to the A bus, depending on the logic level at the direction-control (DIR) input. The output-enable (\overline{OE}) input can be used to disable the outputs so the buses are effectively isolated.

The SN74AVCB324245 is designed so that the control pins (1DIR, 2DIR, $1\overline{OE}$, and $2\overline{OE}$) are supplied by V_{CCB} .

To ensure the high-impedance state during power up or power down, \overline{OE} shall be tied to V_{CCB} through a pullup resistor; the minimum value of the resistor is determined by the current-sinking capability of the driver.

This device is fully specified for partial-power-down applications using I_{off} . The I_{off} circuitry disables the outputs, preventing damaging current backflow through the device when it is powered down. If either V_{CC} input is at GND, both ports are in the high-impedance state.

ORDERING INFORMATION

T_A	PACKAGE ⁽¹⁾		ORDERABLE PART NUMBER	TOP-SIDE MARKING
–40°C to 85°C	LFBGA – GKE	Tape and reel	SN74AVCB324245KR	WD4245
	LFBGA – ZKE (Pb-free)		74AVCB324245ZKER	

(1) Package drawings, standard packing quantities, thermal data, symbolization, and PCB design guidelines are available at www.ti.com/sc/package.



Please be aware that an important notice concerning availability, standard warranty, and use in critical applications of Texas Instruments semiconductor products and disclaimers thereto appears at the end of this data sheet.

Widebus+, DOC are trademarks of Texas Instruments.

SN74AVCB324245
32-BIT DUAL-SUPPLY BUS TRANSCEIVER
WITH CONFIGURABLE VOLTAGE TRANSLATION AND 3-STATE OUTPUTS

SCES485A—AUGUST 2003—REVISED MARCH 2005

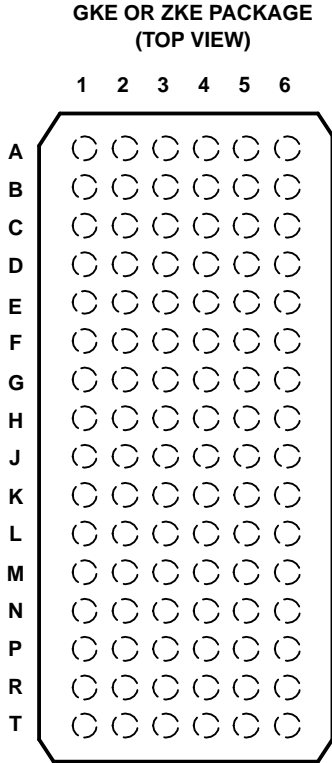

TERMINAL ASSIGNMENTS

	1	2	3	4	5	6
A	1B2	1B1	1DIR	1 \overline{OE}	1A1	1A2
B	1B4	1B3	GND	GND	1A3	1A4
C	1B6	1B5	V _{CCB}	V _{CCA}	1A5	1A6
D	1B8	1B7	GND	GND	1A7	1A8
E	2B2	2B1	GND	GND	2A1	2A2
F	2B4	2B3	V _{CCB}	V _{CCA}	2A3	2A4
G	2B6	2B5	GND	GND	2A5	2A6
H	2B7	2B8	2DIR	2 \overline{OE}	2A8	2A7
J	3B2	3B1	3DIR	3 \overline{OE}	3A1	3A2
K	3B4	3B3	GND	GND	3A3	3A4
L	3B6	3B5	V _{CCB}	V _{CCA}	3A5	3A6
M	3B8	3B7	GND	GND	3A7	3A8
N	4B2	4B1	GND	GND	4A1	4A2
P	4B4	4B3	V _{CCB}	V _{CCA}	4A3	4A4
R	4B6	4B5	GND	GND	4A5	4A6
T	4B7	4B8	4DIR	4 \overline{OE}	4A8	4A7

FUNCTION TABLE (EACH 8-BIT SECTION)

INPUTS		OPERATION
\overline{OE}	DIR	
L	L	B data to A bus
L	H	A data to B bus
H	X	Isolation

LOGIC DIAGRAM (POSITIVE LOGIC)

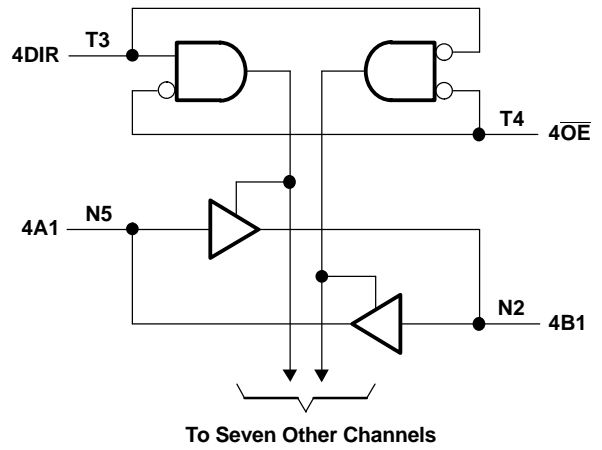
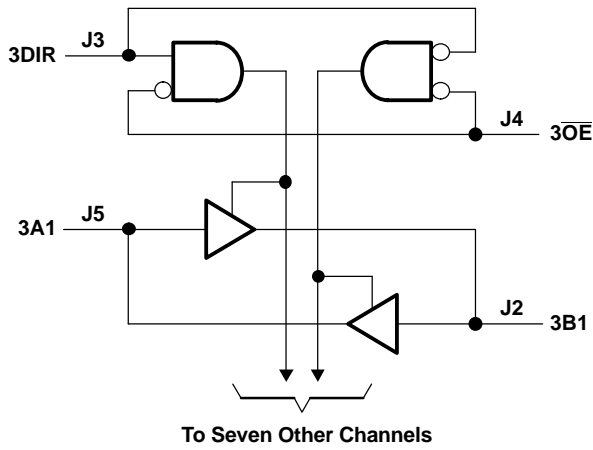
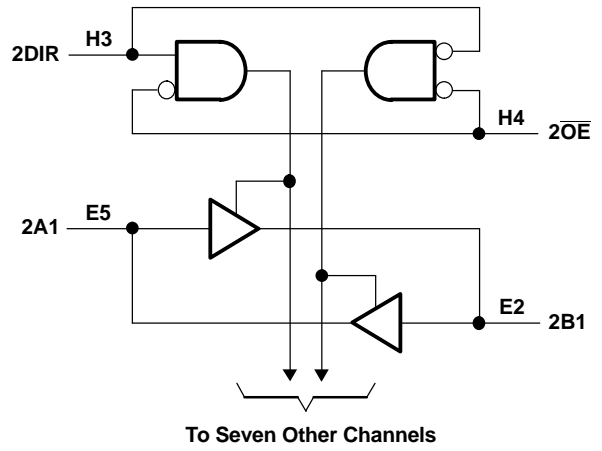
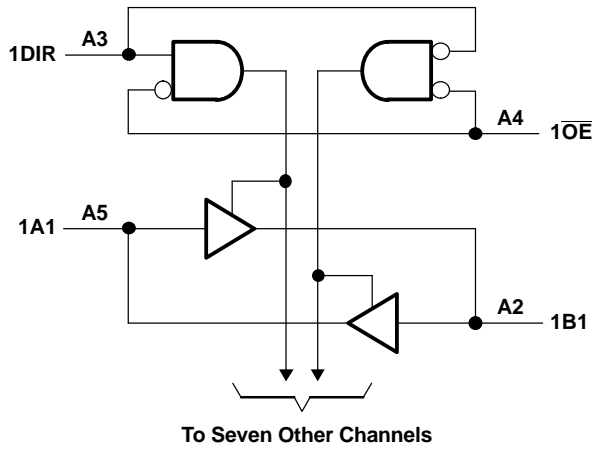

SN74AVCB324245
32-BIT DUAL-SUPPLY BUS TRANSCEIVER
WITH CONFIGURABLE VOLTAGE TRANSLATION AND 3-STATE OUTPUTS



SCES485A–AUGUST 2003–REVISED MARCH 2005

Absolute Maximum Ratings⁽¹⁾

over operating free-air temperature range (unless otherwise noted)

		MIN	MAX	UNIT	
V_{CCA}, V_{CCB}	Supply voltage range	–0.5	4.6	V	
V_I	Input voltage range ⁽²⁾	I/O ports (A port)	–0.5	4.6	V
		I/O ports (B port)	–0.5	4.6	
		Control inputs	–0.5	4.6	
V_O	Voltage range applied to any output in the high-impedance or power-off state ⁽²⁾	A port	–0.5	4.6	V
		B port	–0.5	4.6	
V_O	Voltage range applied to any output in the high or low state ⁽²⁾⁽³⁾	A port	–0.5	$V_{CCA} + 0.5$	V
		B port	–0.5	$V_{CCB} + 0.5$	
I_{IK}	Input clamp current	$V_I < 0$		–50	mA
I_{OK}	Output clamp current	$V_O < 0$		–50	mA
I_O	Continuous output current			±50	mA
		Continuous current through each $V_{CCA}, V_{CCB},$ or GND			±100
θ_{JA}	Package thermal impedance ⁽⁴⁾	GKE/ZKE package		40	°C/W
T_{stg}	Storage temperature range	–65	150		°C

- (1) Stresses beyond those listed under "absolute maximum ratings" may cause permanent damage to the device. These are stress ratings only, and functional operation of the device at these or any other conditions beyond those indicated under "recommended operating conditions" is not implied. Exposure to absolute-maximum-rated conditions for extended periods may affect device reliability.
- (2) The input voltage and output negative-voltage ratings may be exceeded if the input and output current ratings are observed.
- (3) The output positive-voltage rating may be exceeded up to 4.6 V maximum if the output current rating is observed.
- (4) The package thermal impedance is calculated in accordance with JESD 51-7.

Recommended Operating Conditions⁽¹⁾⁽²⁾⁽³⁾

			V _{CCI}	V _{CCO}	MIN	MAX	UNIT
V _{CCA}	Supply voltage				1.4	3.6	V
V _{CCB}	Supply voltage				1.4	3.6	V
V _{IH}	High-level input voltage	Data inputs	1.4 V to 1.95 V		V _{CCI} × 0.65	3.6	V
			1.95 V to 2.7 V		1.7	3.6	
			2.7 V to 3.6 V		2	3.6	
V _{IL}	Low-level input voltage	Data inputs	1.4 V to 1.95 V		0	V _{CCI} × 0.35	V
			1.95 V to 2.7 V		0	0.7	
			2.7 V to 3.6 V		0	0.8	
V _{IH}	High-level input voltage	Control inputs (referenced to V _{CCB})	1.4 V to 1.95 V		V _{CCB} × 0.65	V _{CCB}	V
			1.95 V to 2.7 V		1.7	V _{CCB}	
			2.7 V to 3.6 V		2	V _{CCB}	
V _{IL}	Low-level input voltage	Control inputs (referenced to V _{CCB})	1.4 V to 1.95 V		0	V _{CCB} × 0.35	V
			1.95 V to 2.7 V		0	0.7	
			2.7 V to 3.6 V		0	0.8	
V _O	Output voltage				0	V _{CCO}	V
I _{OH}	High-level output current		1.4 V to 1.6 V			–2	mA
			1.65 V to 1.95 V			–4	
			2.3 V to 2.7 V			–8	
			3 V to 3.6 V			–12	
I _{OL}	Low-level output current		1.4 V to 1.6 V			2	mA
			1.65 V to 1.95 V			4	
			2.3 V to 2.7 V			8	
			3 V to 3.6 V			12	
Δt/Δv	Input transition rise or fall rate					5	ns/V
T _A	Operating free-air temperature				–40	85	°C

(1) V_{CCI} is the V_{CC} associated with the data input port.

(2) V_{CCO} is the V_{CC} associated with the output port.

(3) All unused data inputs of the device must be held at V_{CCI} or GND to ensure proper device operation. Refer to the TI application report, *Implications of Slow or Floating CMOS Inputs*, literature number SCBA004.

SN74AVCB324245
32-BIT DUAL-SUPPLY BUS TRANSCEIVER
WITH CONFIGURABLE VOLTAGE TRANSLATION AND 3-STATE OUTPUTS



SCES485A–AUGUST 2003–REVISED MARCH 2005

Electrical Characteristics⁽¹⁾⁽²⁾

over recommended operating free-air temperature range (unless otherwise noted)

PARAMETER		TEST CONDITIONS	V _{CCA}	V _{CCB}	MIN	TYP ⁽³⁾	MAX	UNIT	
V _{OH}		I _{OH} = -100 μA V _I = V _{IH}	1.4 V to 3.6 V	1.4 V to 3.6 V	V _{CCO} - 0.2			V	
		I _{OH} = -2 mA V _I = V _{IH}	1.4 V	1.4 V	1.05				
		I _{OH} = -4 mA V _I = V _{IH}	1.65 V	1.65 V	1.2				
		I _{OH} = -8 mA V _I = V _{IH}	2.3 V	2.3 V	1.75				
		I _{OH} = -12 mA V _I = V _{IH}	3 V	3 V	2.3				
V _{OL}		I _{OH} = 100 μA V _I = V _{IL}	1.4 V to 3.6 V	1.4 V to 3.6 V	0.2			V	
		I _{OH} = 2 mA V _I = V _{IL}	1.4 V	1.4 V	0.35				
		I _{OH} = 4 mA V _I = V _{IL}	1.65 V	1.65 V	0.45				
		I _{OH} = 8 mA V _I = V _{IL}	2.3 V	2.3 V	0.55				
		I _{OH} = 12 mA V _I = V _{IL}	3 V	3 V	0.7				
V _{OH}		I _{OHD} = -6 mA V _I = V _{IH}	1.4 V	1.4 V	1.05			V	
		I _{OHD} = -9 mA V _I = V _{IH}	1.65 V	1.65 V	1.2				
		I _{OHD} = -15 mA V _I = V _{IH}	2.3 V	2.3 V	1.75				
		I _{OHD} = -24 mA V _I = V _{IH}	3 V	3 V	2.3				
V _{OL}		I _{OHD} = 6 mA V _I = V _{IL}	1.4 V	1.4 V	0.35			V	
		I _{OHD} = 9 mA V _I = V _{IL}	1.65 V	1.65 V	0.45				
		I _{OHD} = 15 mA V _I = V _{IL}	2.3 V	2.3 V	0.55				
		I _{OHD} = 24 mA V _I = V _{IL}	3 V	3 V	0.7				
I _I	Control inputs	V _I = V _{CCB} or GND	1.4 V to 3.6 V	3.6 V	±2.5			μA	
I _{off}	A port	V _I or V _O = 0 to 3.6 V	0 V	0 to 3.6 V	±10			μA	
	B port		0 to 3.6 V	0 V	±10				
I _{OZ} ⁽⁴⁾	A or B ports	V _O = V _{CCO} or GND, V _I = V _{CCI} or GND	OE = V _{IH}	3.6 V	3.6 V	±12.5			μA
	B port		OE = don't care	0 V	3.6 V	±12.5			
	A port			3.6 V	0 V	±12.5			
I _{CCA}		V _I = V _{CCI} or GND, I _O = 0	1.6 V	1.6 V	40			μA	
			1.95 V	1.95 V	40				
			2.7 V	2.7 V	60				
			0 V	3.6 V	-80				
			3.6 V	0 V	80				
			3.6 V	3.6 V	80				
I _{CCB}		V _I = V _{CCI} or GND, I _O = 0	1.6 V	1.6 V	40			μA	
			1.95 V	1.95 V	40				
			2.7 V	2.7 V	60				
			0 V	3.6 V	80				
			3.6 V	0 V	-80				
			3.6 V	3.6 V	80				
C _i	Control inputs	V _I = 3.3 V or GND	3.3 V	3.3 V	4			pF	
C _{io}	A or B ports	V _O = 3.3 V or GND	3.3 V	3.3 V	5			pF	

- (1) V_{CCI} is the V_{CC} associated with the input port.
- (2) V_{CCO} is the V_{CC} associated with the output port.
- (3) All typical values are at T_A = 25°C.
- (4) For I/O ports, the parameter I_{OZ} includes the input leakage current.

Switching Characteristics

over recommended operating free-air temperature range, $V_{CCA} = 1.5\text{ V} \pm 0.1\text{ V}$ (see Figure 2)

PARAMETER	FROM (INPUT)	TO (OUTPUT)	$V_{CCB} = 1.5\text{ V} \pm 0.1\text{ V}$		$V_{CCB} = 1.8\text{ V} \pm 0.15\text{ V}$		$V_{CCB} = 2.5\text{ V} \pm 0.2\text{ V}$		$V_{CCB} = 3.3\text{ V} \pm 0.3\text{ V}$		UNIT
			MIN	MAX	MIN	MAX	MIN	MAX	MIN	MAX	
t_{pd}	A	B	1.7	6.7	1.9	6.4	1.8	5.5	1.5	5.8	ns
	B	A	1.8	6.8	1.7	6.2	1.6	5.9	1.5	5.9	
t_{en}	\overline{OE}	A	2.1	9	2.9	9.8	3.2	10	3	9.8	ns
		B	2.5	8.4	2.4	8	2.3	7.6	2.2	7.5	
t_{dis}	\overline{OE}	A	2.1	7.1	2.3	6.4	1.7	5.1	1.6	4.8	ns
		B	2.2	6.9	1.8	6.4	1.1	5.8	1.8	5.7	

Switching Characteristics

over recommended operating free-air temperature range, $V_{CCA} = 1.8\text{ V} \pm 0.15\text{ V}$ (see Figure 2)

PARAMETER	FROM (INPUT)	TO (OUTPUT)	$V_{CCB} = 1.5\text{ V} \pm 0.1\text{ V}$		$V_{CCB} = 1.8\text{ V} \pm 0.15\text{ V}$		$V_{CCB} = 2.5\text{ V} \pm 0.2\text{ V}$		$V_{CCB} = 3.3\text{ V} \pm 0.3\text{ V}$		UNIT
			MIN	MAX	MIN	MAX	MIN	MAX	MIN	MAX	
t_{pd}	A	B	1.7	6.4	1.8	6	1.7	4.7	1.6	4.3	ns
	B	A	2	6.6	1.8	6	1.8	5.6	1.8	5.5	
t_{en}	\overline{OE}	A	1.8	7.6	2.6	7.7	2.6	7.6	2.6	7.4	ns
		B	2.5	8.2	2.5	7.5	2.4	7.4	2.3	7.2	
t_{dis}	\overline{OE}	A	1.8	7	2.5	6.3	1.8	4.7	1.7	4.4	ns
		B	2.5	6.7	2.3	6.1	2.2	5.5	1.3	5.3	

Switching Characteristics

over recommended operating free-air temperature range, $V_{CCA} = 2.5\text{ V} \pm 0.2\text{ V}$ (see Figure 2)

PARAMETER	FROM (INPUT)	TO (OUTPUT)	$V_{CCB} = 1.5\text{ V} \pm 0.1\text{ V}$		$V_{CCB} = 1.8\text{ V} \pm 0.15\text{ V}$		$V_{CCB} = 2.5\text{ V} \pm 0.2\text{ V}$		$V_{CCB} = 3.3\text{ V} \pm 0.3\text{ V}$		UNIT
			MIN	MAX	MIN	MAX	MIN	MAX	MIN	MAX	
t_{pd}	A	B	1.6	6	1.8	5.6	1.5	4	1.5	3.4	ns
	B	A	1.7	5.4	1.7	4.6	1.5	4	1.5	3.7	
t_{en}	\overline{OE}	A	1.7	5.7	2.2	5.5	2.2	5.3	2.2	5.1	ns
		B	3.1	6.1	2.5	5.6	2.2	5.3	1.9	4.2	
t_{dis}	\overline{OE}	A	1.2	5.8	1.9	5	1.4	3.6	1.3	3.3	ns
		B	2.4	6	3	5.2	1.4	3.6	1.2	3	

Switching Characteristics

over recommended operating free-air temperature range, $V_{CCA} = 3.3\text{ V} \pm 0.3\text{ V}$ (see Figure 2)

PARAMETER	FROM (INPUT)	TO (OUTPUT)	$V_{CCB} = 1.5\text{ V} \pm 0.1\text{ V}$		$V_{CCB} = 1.8\text{ V} \pm 0.15\text{ V}$		$V_{CCB} = 2.5\text{ V} \pm 0.2\text{ V}$		$V_{CCB} = 3.3\text{ V} \pm 0.3\text{ V}$		UNIT
			MIN	MAX	MIN	MAX	MIN	MAX	MIN	MAX	
t_{pd}	A	B	1.5	5.9	1.7	5.4	1.5	3.7	1.4	3.1	ns
	B	A	1.5	5.8	1.5	4.2	1.5	3.3	1.4	3.1	
t_{en}	\overline{OE}	A	1.6	4.9	2	4.5	2	4.3	1.9	4.1	ns
		B	2	5.1	2	4.6	2.2	5.2	1.9	4.1	
t_{dis}	\overline{OE}	A	1.3	6.9	2.1	5.5	1.6	3.8	1.5	3.5	ns
		B	2.3	5.5	1.9	4.5	1.3	3.5	1.2	3.5	

SN74AVCB324245
32-BIT DUAL-SUPPLY BUS TRANSCEIVER
WITH CONFIGURABLE VOLTAGE TRANSLATION AND 3-STATE OUTPUTS

SCES485A–AUGUST 2003–REVISED MARCH 2005

Operating Characteristics

V_{CCA} and $V_{CCB} = 3.3\text{ V}$, $T_A = 25^\circ\text{C}$

PARAMETER		TEST CONDITIONS	TYP	UNIT	
C_{pdA} (V_{CCA})	Power-dissipation capacitance per transceiver, A-port input, B-port output	$C_L = 0$, $f = 10\text{ MHz}$	Outputs enabled	14	pF
			Outputs disabled	7	
	Power-dissipation capacitance per transceiver, B-port input, A-port output		Outputs enabled	20	
			Outputs disabled	7	
C_{pdB} (V_{CCB})	Power-dissipation capacitance per transceiver, A-port input, B-port output	$C_L = 0$, $f = 10\text{ MHz}$	Outputs enabled	20	pF
			Outputs disabled	7	
	Power-dissipation capacitance per transceiver, B-port input, A-port output		Outputs enabled	14	
			Outputs disabled	7	

Output Description

The dynamic output control (DOC™) circuitry is implemented, which, during the transition, initially lowers the output impedance to effectively drive the load and, subsequently, raises the impedance to reduce noise. Figure 1 shows typical V_{OL} vs I_{OL} and V_{OH} vs I_{OH} curves to illustrate the output impedance and drive capability of the circuit. At the beginning of the signal transition, the DOC circuit provides a maximum dynamic drive that is equivalent to a high-drive standard-output device. For more information, refer to the TI application reports, *AVC Logic Family Technology and Applications*, literature number SCEA006, and *Dynamic Output Control (DOC™) Circuitry Technology and Applications*, literature number SCEA009.

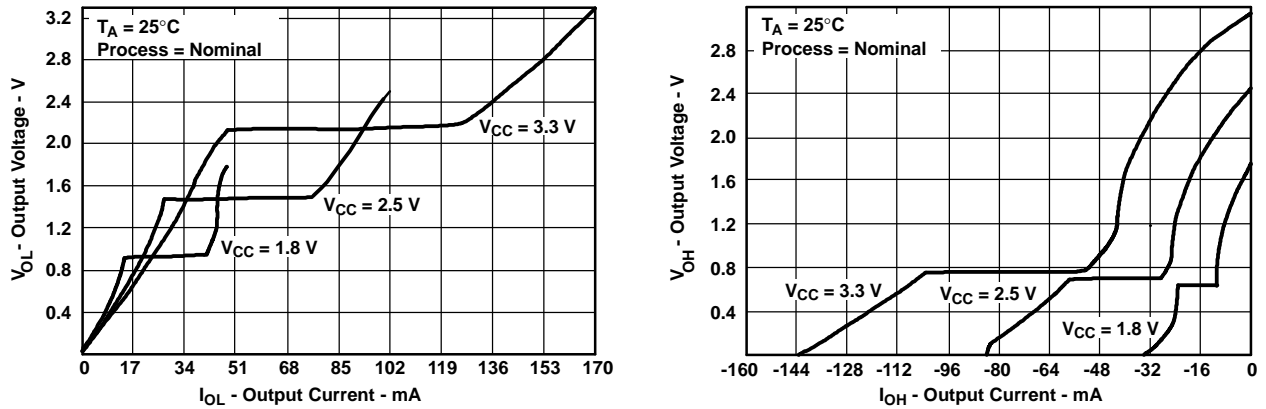
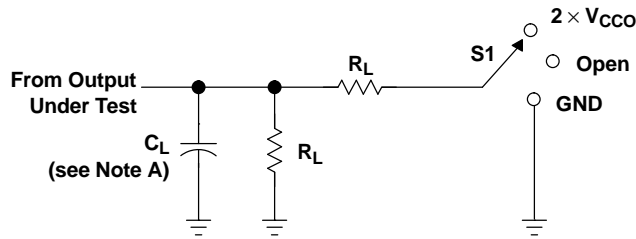

Figure 1. Typical Output Voltage vs Output Current

PARAMETER MEASUREMENT INFORMATION



LOAD CIRCUIT

TEST	S1
t_{pd}	Open
t_{PLZ}/t_{PZL}	$2 \times V_{CCO}$
t_{PHZ}/t_{PZH}	GND

V_{CCO}	C_L	R_L	V_{TP}
$1.5\text{ V} \pm 0.1\text{ V}$	15 pF	2 k Ω	0.1 V
$1.8\text{ V} \pm 0.15\text{ V}$	30 pF	1 k Ω	0.15 V
$2.5\text{ V} \pm 0.2\text{ V}$	30 pF	500 Ω	0.15 V
$3.3\text{ V} \pm 0.3\text{ V}$	30 pF	500 Ω	0.3 V

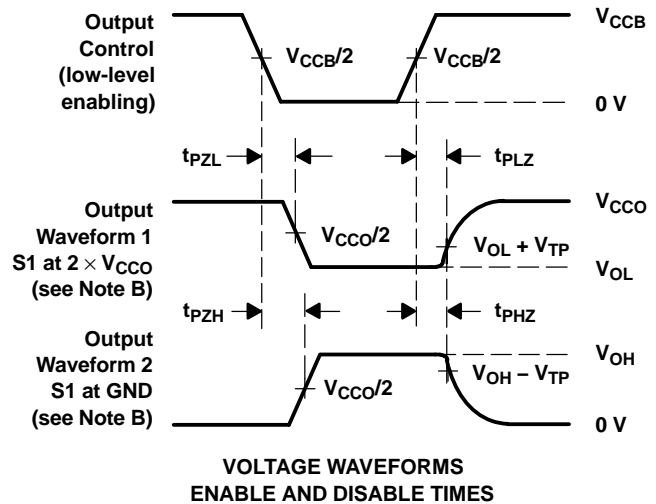
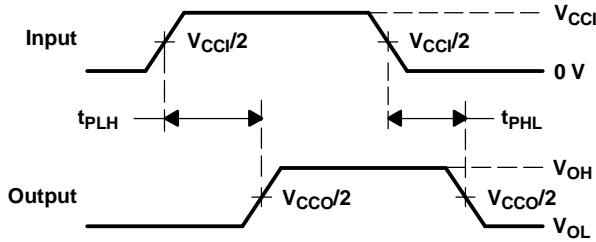
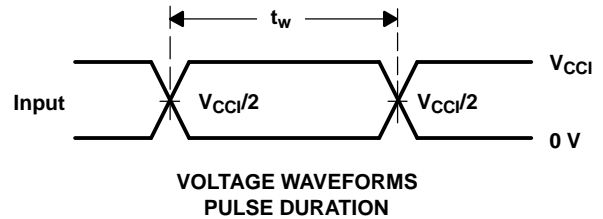

- NOTES: A. C_L includes probe and jig capacitance.
B. Waveform 1 is for an output with internal conditions such that the output is low, except when disabled by the output control. Waveform 2 is for an output with internal conditions such that the output is high, except when disabled by the output control.
C. All input pulses are supplied by generators having the following characteristics: $PRR \leq 10\text{ MHz}$, $Z_O = 50\ \Omega$, $dv/dt \geq 1\text{ V/ns}$, $dv/dt \geq 1\text{ V/ns}$.
D. The outputs are measured one at a time, with one transition per measurement.
E. t_{PLZ} and t_{PHZ} are the same as t_{dis} .
F. t_{PZL} and t_{PZH} are the same as t_{en} .
G. t_{PLH} and t_{PHL} are the same as t_{pd} .
H. V_{CC1} is the V_{CC} associated with the input port.
I. V_{CCO} is the V_{CC} associated with the output port.

Figure 2. Load Circuit and Voltage Waveforms

PACKAGING INFORMATION

Orderable Device	Status (1)	Package Type	Package Drawing	Pins	Package Qty	Eco Plan (2)	Lead/Ball Finish	MSL Peak Temp (3)	Op Temp (°C)	Top-Side Markings (4)	Samples
74AVCB324245ZKER	ACTIVE	LFBGA	ZKE	96	1000	Green (RoHS & no Sb/Br)	SNAGCU	Level-3-260C-168 HR	-40 to 85	WD4245	Samples
SN74AVCB324245KR	ACTIVE	LFBGA	GKE	96	1000	TBD	SNPB	Level-2-235C-1 YEAR	-40 to 85	WD4245	Samples

(1) The marketing status values are defined as follows:

ACTIVE: Product device recommended for new designs.

LIFEBUY: TI has announced that the device will be discontinued, and a lifetime-buy period is in effect.

NRND: Not recommended for new designs. Device is in production to support existing customers, but TI does not recommend using this part in a new design.

PREVIEW: Device has been announced but is not in production. Samples may or may not be available.

OBSOLETE: TI has discontinued the production of the device.

(2) Eco Plan - The planned eco-friendly classification: Pb-Free (RoHS), Pb-Free (RoHS Exempt), or Green (RoHS & no Sb/Br) - please check <http://www.ti.com/productcontent> for the latest availability information and additional product content details.

TBD: The Pb-Free/Green conversion plan has not been defined.

Pb-Free (RoHS): TI's terms "Lead-Free" or "Pb-Free" mean semiconductor products that are compatible with the current RoHS requirements for all 6 substances, including the requirement that lead not exceed 0.1% by weight in homogeneous materials. Where designed to be soldered at high temperatures, TI Pb-Free products are suitable for use in specified lead-free processes.

Pb-Free (RoHS Exempt): This component has a RoHS exemption for either 1) lead-based flip-chip solder bumps used between the die and package, or 2) lead-based die adhesive used between the die and leadframe. The component is otherwise considered Pb-Free (RoHS compatible) as defined above.

Green (RoHS & no Sb/Br): TI defines "Green" to mean Pb-Free (RoHS compatible), and free of Bromine (Br) and Antimony (Sb) based flame retardants (Br or Sb do not exceed 0.1% by weight in homogeneous material)

(3) MSL, Peak Temp. -- The Moisture Sensitivity Level rating according to the JEDEC industry standard classifications, and peak solder temperature.

(4) Multiple Top-Side Markings will be inside parentheses. Only one Top-Side Marking contained in parentheses and separated by a "~" will appear on a device. If a line is indented then it is a continuation of the previous line and the two combined represent the entire Top-Side Marking for that device.

Important Information and Disclaimer: The information provided on this page represents TI's knowledge and belief as of the date that it is provided. TI bases its knowledge and belief on information provided by third parties, and makes no representation or warranty as to the accuracy of such information. Efforts are underway to better integrate information from third parties. TI has taken and continues to take reasonable steps to provide representative and accurate information but may not have conducted destructive testing or chemical analysis on incoming materials and chemicals. TI and TI suppliers consider certain information to be proprietary, and thus CAS numbers and other limited information may not be available for release.

In no event shall TI's liability arising out of such information exceed the total purchase price of the TI part(s) at issue in this document sold by TI to Customer on an annual basis.

TAPE AND REEL INFORMATION



QUADRANT ASSIGNMENTS FOR PIN 1 ORIENTATION IN TAPE



*All dimensions are nominal

Device	Package Type	Package Drawing	Pins	SPQ	Reel Diameter (mm)	Reel Width W1 (mm)	A0 (mm)	B0 (mm)	K0 (mm)	P1 (mm)	W (mm)	Pin1 Quadrant
74AVCB324245ZKER	LFBGA	ZKE	96	1000	330.0	24.4	5.7	13.7	2.0	8.0	24.0	Q1
SN74AVCB324245KR	LFBGA	GKE	96	1000	330.0	24.4	5.7	13.7	2.0	8.0	24.0	Q1

TAPE AND REEL BOX DIMENSIONS



*All dimensions are nominal

Device	Package Type	Package Drawing	Pins	SPQ	Length (mm)	Width (mm)	Height (mm)
74AVCB324245ZKER	LFBGA	ZKE	96	1000	336.6	336.6	41.3
SN74AVCB324245KR	LFBGA	GKE	96	1000	336.6	336.6	41.3

GKE (R-PBGA-N96)

PLASTIC BALL GRID ARRAY

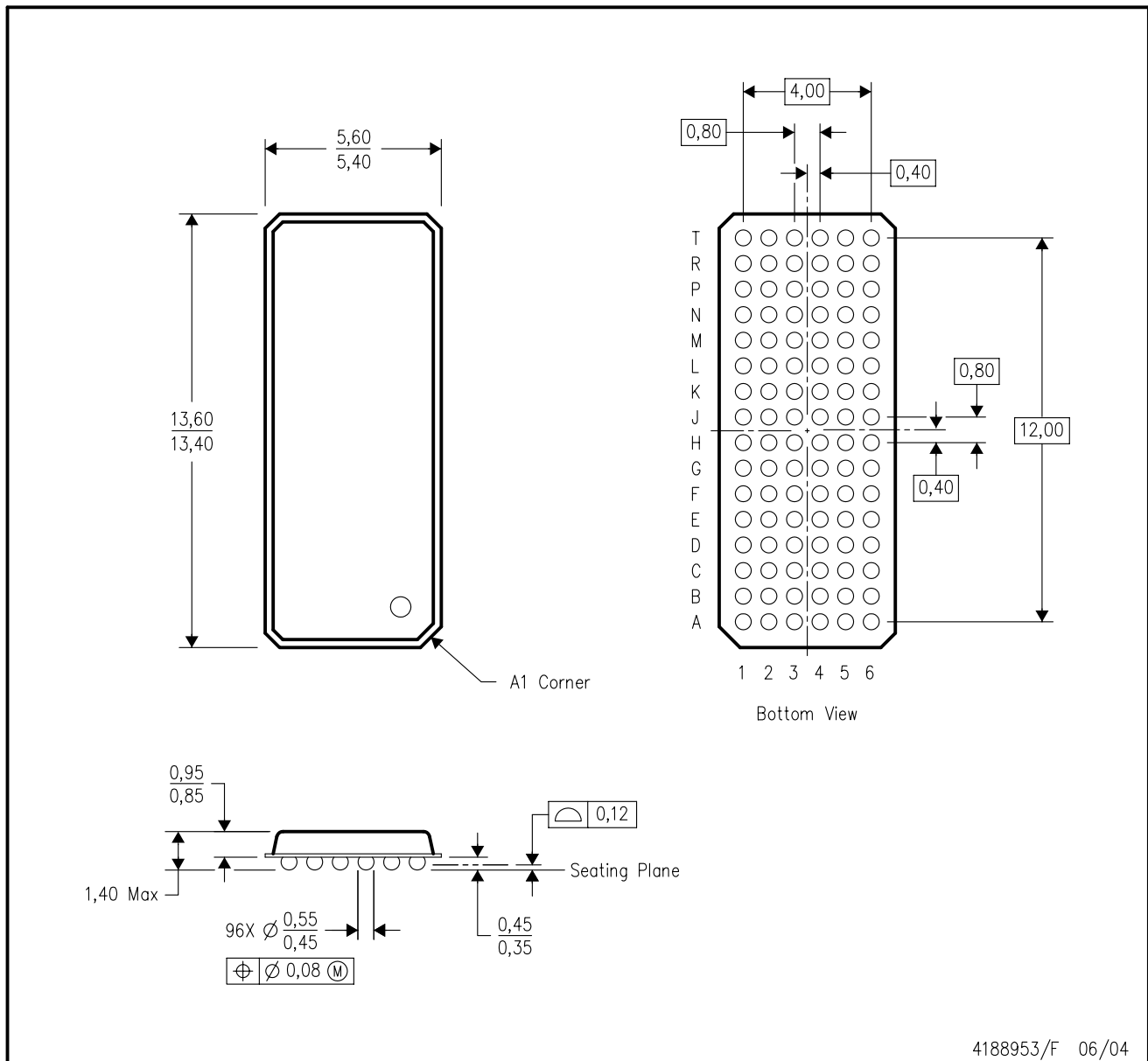

4188953/F 06/04

- NOTES:
- A. All linear dimensions are in millimeters.
 - B. This drawing is subject to change without notice.
 - C. Falls within JEDEC MO-205 variation CC.
 - D. This package is tin-lead (SnPb). Refer to the 96 ZKE package (drawing 4204493) for lead-free.

ZKE (R-PBGA-N96)

PLASTIC BALL GRID ARRAY

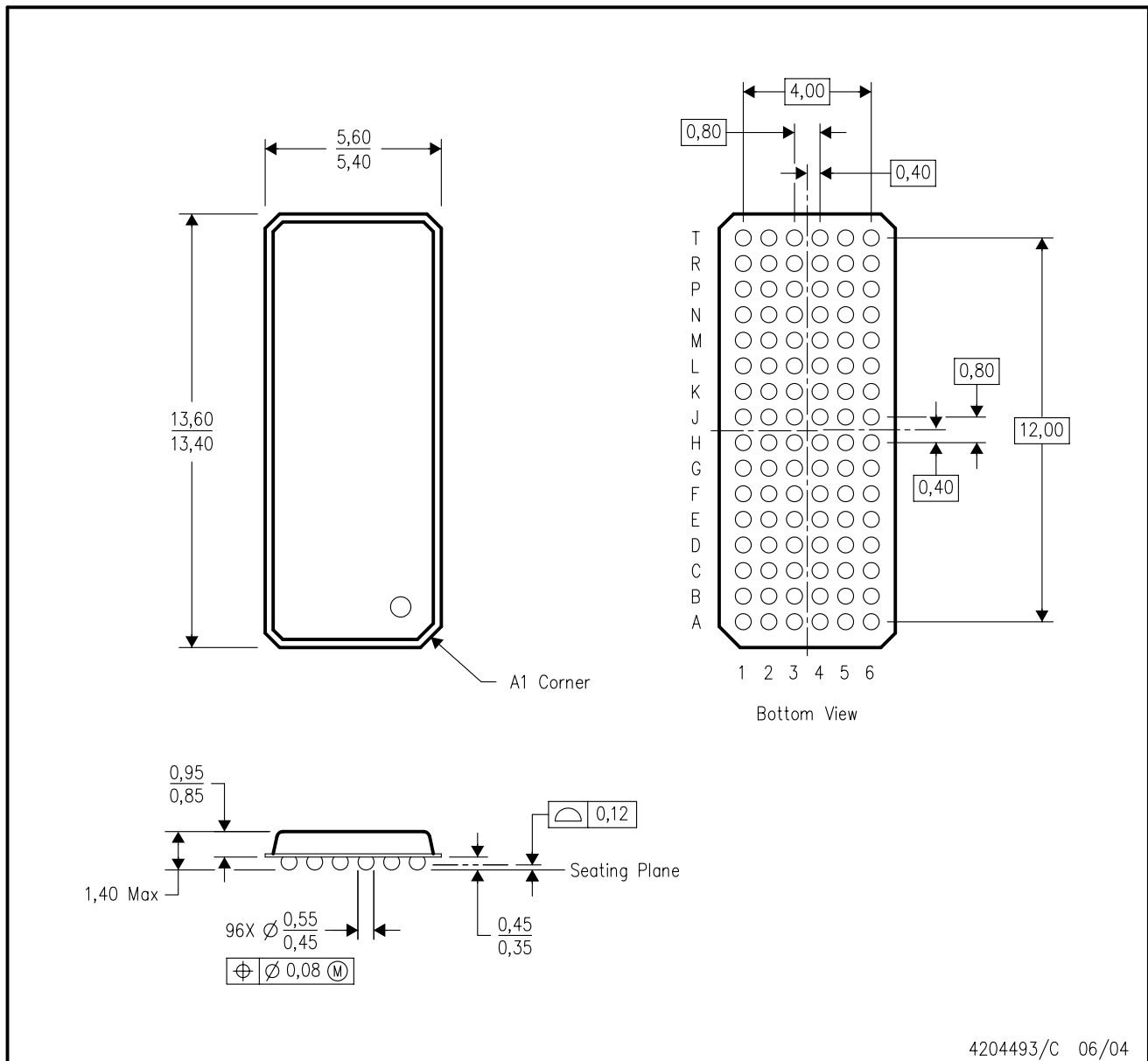

- NOTES:
- A. All linear dimensions are in millimeters.
 - B. This drawing is subject to change without notice.
 - C. Falls within JEDEC MO-205 variation CC.
 - D. This package is lead-free. Refer to the 96 GKE package (drawing 4188953) for tin-lead (SnPb).

IMPORTANT NOTICE

Texas Instruments Incorporated (TI) reserves the right to make corrections, enhancements, improvements and other changes to its semiconductor products and services per JESD46, latest issue, and to discontinue any product or service per JESD48, latest issue. Buyers should obtain the latest relevant information before placing orders and should verify that such information is current and complete.

TI's published terms of sale for semiconductor products (<http://www.ti.com/sc/docs/stdterms.htm>) apply to the sale of packaged integrated circuit products that TI has qualified and released to market. Additional terms may apply to the use or sale of other types of TI products and services.

Reproduction of significant portions of TI information in TI data sheets is permissible only if reproduction is without alteration and is accompanied by all associated warranties, conditions, limitations, and notices. TI is not responsible or liable for such reproduced documentation. Information of third parties may be subject to additional restrictions. Resale of TI products or services with statements different from or beyond the parameters stated by TI for that product or service voids all express and any implied warranties for the associated TI product or service and is an unfair and deceptive business practice. TI is not responsible or liable for any such statements.

Buyers and others who are developing systems that incorporate TI products (collectively, "Designers") understand and agree that Designers remain responsible for using their independent analysis, evaluation and judgment in designing their applications and that Designers have full and exclusive responsibility to assure the safety of Designers' applications and compliance of their applications (and of all TI products used in or for Designers' applications) with all applicable regulations, laws and other applicable requirements. Designer represents that, with respect to their applications, Designer has all the necessary expertise to create and implement safeguards that (1) anticipate dangerous consequences of failures, (2) monitor failures and their consequences, and (3) lessen the likelihood of failures that might cause harm and take appropriate actions. Designer agrees that prior to using or distributing any applications that include TI products, Designer will thoroughly test such applications and the functionality of such TI products as used in such applications.

TI's provision of technical, application or other design advice, quality characterization, reliability data or other services or information, including, but not limited to, reference designs and materials relating to evaluation modules, (collectively, "TI Resources") are intended to assist designers who are developing applications that incorporate TI products; by downloading, accessing or using TI Resources in any way, Designer (individually or, if Designer is acting on behalf of a company, Designer's company) agrees to use any particular TI Resource solely for this purpose and subject to the terms of this Notice.

TI's provision of TI Resources does not expand or otherwise alter TI's applicable published warranties or warranty disclaimers for TI products, and no additional obligations or liabilities arise from TI providing such TI Resources. TI reserves the right to make corrections, enhancements, improvements and other changes to its TI Resources. TI has not conducted any testing other than that specifically described in the published documentation for a particular TI Resource.

Designer is authorized to use, copy and modify any individual TI Resource only in connection with the development of applications that include the TI product(s) identified in such TI Resource. NO OTHER LICENSE, EXPRESS OR IMPLIED, BY ESTOPPEL OR OTHERWISE TO ANY OTHER TI INTELLECTUAL PROPERTY RIGHT, AND NO LICENSE TO ANY TECHNOLOGY OR INTELLECTUAL PROPERTY RIGHT OF TI OR ANY THIRD PARTY IS GRANTED HEREIN, including but not limited to any patent right, copyright, mask work right, or other intellectual property right relating to any combination, machine, or process in which TI products or services are used. Information regarding or referencing third-party products or services does not constitute a license to use such products or services, or a warranty or endorsement thereof. Use of TI Resources may require a license from a third party under the patents or other intellectual property of the third party, or a license from TI under the patents or other intellectual property of TI.

TI RESOURCES ARE PROVIDED "AS IS" AND WITH ALL FAULTS. TI DISCLAIMS ALL OTHER WARRANTIES OR REPRESENTATIONS, EXPRESS OR IMPLIED, REGARDING RESOURCES OR USE THEREOF, INCLUDING BUT NOT LIMITED TO ACCURACY OR COMPLETENESS, TITLE, ANY EPIDEMIC FAILURE WARRANTY AND ANY IMPLIED WARRANTIES OF MERCHANTABILITY, FITNESS FOR A PARTICULAR PURPOSE, AND NON-INFRINGEMENT OF ANY THIRD PARTY INTELLECTUAL PROPERTY RIGHTS. TI SHALL NOT BE LIABLE FOR AND SHALL NOT DEFEND OR INDEMNIFY DESIGNER AGAINST ANY CLAIM, INCLUDING BUT NOT LIMITED TO ANY INFRINGEMENT CLAIM THAT RELATES TO OR IS BASED ON ANY COMBINATION OF PRODUCTS EVEN IF DESCRIBED IN TI RESOURCES OR OTHERWISE. IN NO EVENT SHALL TI BE LIABLE FOR ANY ACTUAL, DIRECT, SPECIAL, COLLATERAL, INDIRECT, PUNITIVE, INCIDENTAL, CONSEQUENTIAL OR EXEMPLARY DAMAGES IN CONNECTION WITH OR ARISING OUT OF TI RESOURCES OR USE THEREOF, AND REGARDLESS OF WHETHER TI HAS BEEN ADVISED OF THE POSSIBILITY OF SUCH DAMAGES.

Unless TI has explicitly designated an individual product as meeting the requirements of a particular industry standard (e.g., ISO/TS 16949 and ISO 26262), TI is not responsible for any failure to meet such industry standard requirements.

Where TI specifically promotes products as facilitating functional safety or as compliant with industry functional safety standards, such products are intended to help enable customers to design and create their own applications that meet applicable functional safety standards and requirements. Using products in an application does not by itself establish any safety features in the application. Designers must ensure compliance with safety-related requirements and standards applicable to their applications. Designer may not use any TI products in life-critical medical equipment unless authorized officers of the parties have executed a special contract specifically governing such use. Life-critical medical equipment is medical equipment where failure of such equipment would cause serious bodily injury or death (e.g., life support, pacemakers, defibrillators, heart pumps, neurostimulators, and implantables). Such equipment includes, without limitation, all medical devices identified by the U.S. Food and Drug Administration as Class III devices and equivalent classifications outside the U.S.

TI may expressly designate certain products as completing a particular qualification (e.g., Q100, Military Grade, or Enhanced Product). Designers agree that it has the necessary expertise to select the product with the appropriate qualification designation for their applications and that proper product selection is at Designers' own risk. Designers are solely responsible for compliance with all legal and regulatory requirements in connection with such selection.

Designer will fully indemnify TI and its representatives against any damages, costs, losses, and/or liabilities arising out of Designer's non-compliance with the terms and provisions of this Notice.

Looking for pricing, stock, or lifecycle information?

Click below to explore more details on WIN SOURCE:

 [View 74AVCB324245ZKER](#) on WIN SOURCE

 [Texas Instruments](#) Information

Optimize Your Supply Chain with WIN SOURCE Solutions

-  Global Sourcing Solution
-  Obsolete Management
-  Cost Control Management
-  Shortage Management
-  Alternative Solution
-  Excess Inventory Management