



**THE DATASHEET OF
74AVC4T245QRYRQ1**



Table of Contents

1 Features	1	8 Detailed Description	15
2 Applications	1	8.1 Overview	15
3 Description	1	8.2 Functional Block Diagram	15
4 Revision History	2	8.3 Feature Description	16
5 Pin Configuration and Functions	3	8.4 Device Functional Modes	16
6 Specifications	4	9 Application and Implementation	17
6.1 Absolute Maximum Ratings	4	9.1 Application Information	17
6.2 ESD Ratings	4	9.2 Typical Application	17
6.3 Recommended Operating Conditions	4	10 Power Supply Recommendations	19
6.4 Thermal Information	5	11 Layout	19
6.5 Electrical Characteristics	5	11.1 Layout Guidelines	19
6.6 Switching Characteristics: $V_{CCA} = 1.2\text{ V}$	7	11.2 Layout Example	19
6.7 Switching Characteristics: $V_{CCA} = 1.5\text{ V} \pm 0.1\text{ V}$	8	12 Device and Documentation Support	20
6.8 Switching Characteristics: $V_{CCA} = 1.8\text{ V} \pm 0.15\text{ V}$	8	12.1 Documentation Support	20
6.9 Switching Characteristics: $V_{CCA} = 2.5\text{ V} \pm 0.2\text{ V}$	9	12.2 Trademarks	20
6.10 Switching Characteristics: $V_{CCA} = 3.3\text{ V} \pm 0.3\text{ V}$	10	12.3 Electrostatic Discharge Caution	20
6.11 Operating Characteristics	11	12.4 Glossary	20
6.12 Typical Characteristics	12	13 Mechanical, Packaging, and Orderable Information	20
7 Parameter Measurement Information	14		

4 Revision History

NOTE: Page numbers for previous revisions may differ from page numbers in the current version.

Changes from Revision A (October 2012) to Revision B	Page
• Added <i>Applications</i> section	1
• Added -Q1 to the part number throughout the data sheet	1
• Added <i>Device Information</i> table to the data sheet	1
• Deleted <i>Ordering Information</i> table from the data sheet	1
• Added <i>Pin Functions</i> table to the data sheet	3
• Added <i>ESD Ratings</i> table to the data sheet	4
• Added <i>Thermal Information</i> table to the data sheet	5
• Added <i>Typical Characteristics</i> to the data sheet	12
• Added Figure 1 through Figure 9 from the SN74AVC8T245-Q1 data sheet over to the <i>Typical Characteristics</i> section	12
• Added all new content from <i>Application Information</i> through the end of the data sheet	15

Changes from Original (November 2009) to Revision A	Page
• Added AEC-Q100 info to Features	1
• Removed ESD Protection Exceeds JESD 22, 8000-V Human-Body Model (A114-A), 1000-V Charged-Device Model (C101) from Features.	1

5 Pin Configuration and Functions

RGY Package
16-Pin VQFN With Exposed Thermal Pad
Top View

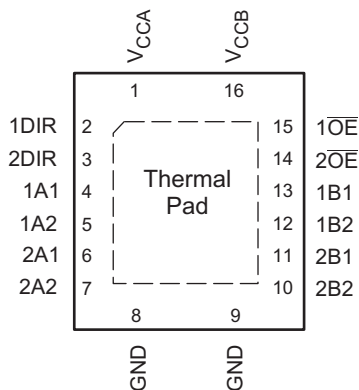

Pin Functions

PIN		TYPE	DESCRIPTION
NAME	NO.		
1A1	4	I/O	Input/output 1A1. Referenced to V_{CCA} .
1A2	5	I/O	Input/output 1A2. Referenced to V_{CCA} .
1B1	13	I/O	Input/output 1B1. Referenced to V_{CCB} .
1B2	12	I/O	Input/output 1B2. Referenced to V_{CCB} .
1DIR	2	I	Direction-control input for 1 ports
$1\overline{OE}$	15	I	3-state output-mode enable. Pull \overline{OE} high to place '1' outputs in 3-state mode. Referenced to V_{CCA} .
2A1	6	I/O	Input/output 2A1. Referenced to V_{CCA} .
2A2	7	I/O	Input/output 2A2. Referenced to V_{CCA} .
2B1	11	I/O	Input/output 2B1. Referenced to V_{CCB} .
2B2	10	I/O	Input/output 2B2. Referenced to V_{CCB} .
2DIR	3	I	Direction-control input for 2 ports
$2\overline{OE}$	14	I	3-state output-mode enable. Pull \overline{OE} high to place '2' outputs in 3-state mode. Referenced to V_{CCA} .
GND	8, 9	—	Ground
Thermal pad	—	—	The exposed thermal pad must be connected as a secondary GND or be left electrically open.
V_{CCA}	1	I	A-port power supply voltage. $1.2\text{ V} \leq V_{CCA} \leq 3.6\text{ V}$
V_{CCB}	16	I	B-port power supply voltage. $1.2\text{ V} \leq V_{CCB} \leq 3.6\text{ V}$

6 Specifications

6.1 Absolute Maximum Ratings⁽¹⁾

over operating ambient temperature range (unless otherwise noted)

		MIN	MAX	UNIT	
V_{CCA} V_{CCB}	Supply voltage	-0.5	4.6	V	
V_I	Input voltage ⁽²⁾	I/O ports (A port)	-0.5	4.6	V
		I/O ports (B port)	-0.5	4.6	
		Control inputs	-0.5	4.6	
V_O	Voltage applied to any output in the high-impedance or power-off state ⁽²⁾	A port	-0.5	4.6	V
		B port	-0.5	4.6	
V_O	Voltage applied to any output in the high or low state ^{(2) (3)}	A port	-0.5	$V_{CCA} + 0.5$	V
		B port	-0.5	$V_{CCB} + 0.5$	
I_{IK}	Input clamp current	$V_I < 0$	-50	mA	
I_{OK}	Output clamp current	$V_O < 0$	-50	mA	
I_O	Continuous output current		±50	mA	
	Continuous current through V_{CCA} , V_{CCB} , or GND		±100	mA	
T_{stg}	Storage temperature	-65	150	°C	

- (1) Stresses beyond those listed under *Absolute Maximum Ratings* may cause permanent damage to the device. These are stress ratings only, and do not imply functional operation of the device at these or any other conditions beyond those indicated under *Recommended Operating Conditions*. Exposure to absolute-maximum-rated conditions for extended periods may affect device reliability.
- (2) The input voltage and output negative-voltage ratings may be exceeded if the input and output current ratings are observed.
- (3) The output positive-voltage rating may be exceeded up to 4.6 V maximum if the output current rating is observed.

6.2 ESD Ratings

		VALUE	UNIT	
$V_{(ESD)}$	Electrostatic discharge	Human body model (HBM), per ANSI/ESDA/JEDEC JS-001, all pins ⁽¹⁾	±8000	V
		Charged device model (CDM), per JEDEC specification JESD22-C101, all pins ⁽²⁾	±1000	
		Machine model (C101)	±150	

- (1) JEDEC document JEP155 states that 500-V HBM allows safe manufacturing with a standard ESD control process.
- (2) JEDEC document JEP157 states that 250-V CDM allows safe manufacturing with a standard ESD control process.

6.3 Recommended Operating Conditions^{(1) (2) (3)}

		V_{CCI}	V_{CCO}	MIN	MAX	UNIT
V_{CCA}	Supply voltage			1.2	3.6	V
V_{CCB}	Supply voltage			1.2	3.6	V
V_{IH}	High-level input voltage	Data inputs ⁽⁴⁾	1.2 V to 1.95 V	$V_{CCI} \times 0.65$		V
			1.95 V to 2.7 V	1.6		
			2.7 V to 3.6 V	2		
V_{IL}	Low-level input voltage	Data inputs ⁽⁴⁾	1.2 V to 1.95 V	$V_{CCI} \times 0.35$		V
			1.95 V to 2.7 V	0.7		
			2.7 V to 3.6 V	0.8		
V_{IH}	High-level input voltage	DIR (referenced to V_{CCA}) ⁽⁵⁾	1.2 V to 1.95 V	$V_{CCA} \times 0.65$		V
			1.95 V to 2.7 V	1.6		
			2.7 V to 3.6 V	2		

- (1) V_{CCI} is the V_{CC} associated with the input port.
- (2) V_{CCO} is the V_{CC} associated with the output port.
- (3) All unused data inputs of the device must be held at V_{CCI} or GND to ensure proper device operation. See the TI application report, *Implications of Slow or Floating CMOS Inputs*, [SCBA004](#).
- (4) For V_{CCI} values not specified in the data sheet, $V_{IH} \text{ min} = V_{CCI} \times 0.7 \text{ V}$, $V_{IL} \text{ max} = V_{CCI} \times 0.3 \text{ V}$
- (5) For V_{CCA} values not specified in the data sheet, $V_{IH} \text{ min} = V_{CCA} \times 0.7 \text{ V}$, $V_{IL} \text{ max} = V_{CCA} \times 0.3 \text{ V}$

Recommended Operating Conditions^{(1) (2) (3)} (continued)

		V_{CCI}	V_{CCO}	MIN	MAX	UNIT
V_{IL}	Low-level input voltage	DIR (referenced to V_{CCA}) ⁽⁵⁾	1.2 V to 1.95 V		$V_{CCA} \times 0.35$	V
			1.95 V to 2.7 V		0.7	
			2.7 V to 3.6 V		0.8	
V_I	Input voltage			0	3.6	V
V_O	Output voltage	Active state		0	V_{CCO}	V
		3-state		0	3.6	
I_{OH}	High-level output current		1.2 V		-3	mA
			1.4 V to 1.6 V		-6	
			1.65 V to 1.95 V		-8	
			2.3 V to 2.7 V		-9	
			3 V to 3.6 V		-12	
I_{OL}	Low-level output current		1.1 V to 1.2 V		3	mA
			1.4 V to 1.6 V		6	
			1.65 V to 1.95 V		8	
			2.3 V to 2.7 V		9	
			3 V to 3.6 V		12	
$\Delta t/\Delta v$	Input transition rise or fall rate				5	ns/V
T_A	Operating ambient temperature			-40	125	°C

6.4 Thermal Information

THERMAL METRIC ⁽¹⁾		SN74AVC4T245-Q1	UNIT
		RGY (VQFN)	
		16 PINS	
$R_{\theta JA}$	Junction-to-ambient thermal resistance	37.5	°C/W
$R_{\theta JC(top)}$	Junction-to-case (top) thermal resistance	54.5	°C/W
$R_{\theta JB}$	Junction-to-board thermal resistance	15.6	°C/W
Ψ_{JT}	Junction-to-top characterization parameter	0.5	°C/W
Ψ_{JB}	Junction-to-board characterization parameter	15.8	°C/W
$R_{\theta JC(bot)}$	Junction-to-case (bottom) thermal resistance	3.5	°C/W

(1) For more information about traditional and new thermal metrics, see the *Semiconductor and IC Package Thermal Metrics* application report (SPRA953).

6.5 Electrical Characteristics^{(1) (2)}

over recommended operating ambient temperature range (unless otherwise noted)

PARAMETER	TEST CONDITIONS	V_{CCA}	V_{CCB}	T_A	MIN	TYP	MAX	UNIT
V_{OH}	$I_{OH} = -100 \mu A$	$V_I = V_{IH}$	1.2 V to 3.6 V	1.2 V to 3.6 V	$T_A = -40^\circ C$ to $125^\circ C$	$V_{CCO} - 0.2$		V
	$I_{OH} = -3 \text{ mA}$		1.2 V	1.2 V	$T_A = 25^\circ C$	0.95		
	$I_{OH} = -6 \text{ mA}$		1.4 V	1.4 V	$T_A = -40^\circ C$ to $125^\circ C$	1.05		
	$I_{OH} = -8 \text{ mA}$		1.65 V	1.65 V	$T_A = -40^\circ C$ to $125^\circ C$	1.2		
	$I_{OH} = -9 \text{ mA}$		2.3 V	2.3 V	$T_A = -40^\circ C$ to $125^\circ C$	1.75		
	$I_{OH} = -12 \text{ mA}$		3 V	3 V	$T_A = -40^\circ C$ to $125^\circ C$	2.3		

(1) V_{CCO} is the V_{CC} associated with the output port.

(2) V_{CCI} is the V_{CC} associated with the input port.

Electrical Characteristics^{(1) (2)} (continued)

over recommended operating ambient temperature range (unless otherwise noted)

PARAMETER		TEST CONDITIONS	V _{CCA}	V _{CCB}	T _A	MIN	TYP	MAX	UNIT
V _{OL}		V _I = V _{IL}	1.2 V to 3.6 V	1.2 V to 3.6 V	T _A = -40°C to 125°C			0.2	V
			1.2 V	1.2 V	T _A = 25°C		0.25		
			1.4 V	1.4 V	T _A = -40°C to 125°C		0.35		
			1.65 V	1.65 V	T _A = -40°C to 125°C		0.45		
			2.3 V	2.3 V	T _A = -40°C to 125°C		0.55		
			3 V	3 V	T _A = -40°C to 125°C		0.7		
I _I ⁽³⁾	Control inputs	V _I = V _{CCA} or GND	1.2 V to 3.6 V	1.2 V to 3.6 V	T _A = 25°C		±0.025	±0.25	μA
					T _A = -40°C to 125°C			±1.5	
I _{off}	A or B port	V _I or V _O = 0 to 3.6 V	0 V	0 V to 3.6 V	T _A = 25°C		±0.1	±1	μA
					T _A = -40°C to 125°C			±5	
			0 V to 3.6 V	0 V	T _A = 25°C		±0.1	±1	
					T _A = -40°C to 125°C			±5	
I _{OZ}	A or B port	V _O = V _{CCO} or GND, V _I = V _{CCI} or GND, \overline{OE} = V _{IH}	3.6 V	3.6 V	T _A = 25°C		±0.5	±2.5	μA
					T _A = -40°C to 125°C			±5	
I _{CCA} ⁽³⁾		V _I = V _{CCI} or GND, I _O = 0	1.2 V to 3.6 V	1.2 V to 3.6 V	T _A = -40°C to 125°C			8	μA
					T _A = 25°C			-2	
			0 V	0 V to 3.6 V	T _A = -40°C to 125°C			-11	
					T _A = 25°C			8	
I _{CCB} ⁽³⁾		V _I = V _{CCI} or GND, I _O = 0	1.2 V to 3.6 V	1.2 V to 3.6 V	T _A = -40°C to 125°C			8	μA
					T _A = 25°C			8	
			0 V	0 V to 3.6 V	T _A = -40°C to 125°C			-2	
					T _A = 25°C			-11	
I _{CCA} + I _{CCB}		V _I = V _{CCI} or GND, I _O = 0	1.2 V to 3.6 V	1.2 V to 3.6 V	T _A = -40°C to 125°C			16	μA
C _i	Control inputs	V _I = 3.3 V or GND	3.3 V	3.3 V	T _A = 25°C		3.5	4.5	pF
					T _A = -40°C to 125°C			7	
C _{io}	A or B port	V _O = 3.3 V or GND	3.3 V	3.3 V	T _A = 25°C		6		pF
					T _A = -40°C to 125°C				

(3) All unused data inputs of the device must be held at V_{CCI} or GND to ensure proper device operation. See the TI application report, *Implications of Slow or Floating CMOS Inputs*, [SCBA004](#).

6.6 Switching Characteristics: $V_{CCA} = 1.2\text{ V}$

over recommended operating ambient temperature range, $V_{CCA} = 1.2\text{ V}$ (unless otherwise noted) (see [Figure 12](#))

PARAMETER	FROM (INPUT)	TO (OUTPUT)	V_{CCB}	TYP	UNIT
t_{PHL} , t_{PLH}	A	B	$V_{CCB} = 1.2\text{ V}$	3.4	ns
			$V_{CCB} = 1.5\text{ V} \pm 0.1\text{ V}$	2.9	
			$V_{CCB} = 1.8\text{ V} \pm 0.15\text{ V}$	2.7	
			$V_{CCB} = 2.5\text{ V} \pm 0.2\text{ V}$	2.6	
			$V_{CCB} = 3.3\text{ V} \pm 0.3\text{ V}$	2.8	
t_{PHL} , t_{PLH}	B	A	$V_{CCB} = 1.2\text{ V}$	3.6	ns
			$V_{CCB} = 1.5\text{ V} \pm 0.1\text{ V}$	3.1	
			$V_{CCB} = 1.8\text{ V} \pm 0.15\text{ V}$	2.8	
			$V_{CCB} = 2.5\text{ V} \pm 0.2\text{ V}$	2.6	
			$V_{CCB} = 3.3\text{ V} \pm 0.3\text{ V}$	2.6	
t_{PHZ} , t_{PLZ}	\overline{OE}	A	$V_{CCB} = 1.2\text{ V}$	5.6	ns
			$V_{CCB} = 1.5\text{ V} \pm 0.1\text{ V}$	4.7	
			$V_{CCB} = 1.8\text{ V} \pm 0.15\text{ V}$	4.3	
			$V_{CCB} = 2.5\text{ V} \pm 0.2\text{ V}$	3.9	
			$V_{CCB} = 3.3\text{ V} \pm 0.3\text{ V}$	3.7	
t_{PZH}	\overline{OE}	B	$V_{CCB} = 1.2\text{ V}$	5	ns
			$V_{CCB} = 1.5\text{ V} \pm 0.1\text{ V}$	4.3	
			$V_{CCB} = 1.8\text{ V} \pm 0.15\text{ V}$	3.9	
			$V_{CCB} = 2.5\text{ V} \pm 0.2\text{ V}$	3.6	
			$V_{CCB} = 3.3\text{ V} \pm 0.3\text{ V}$	36.6	
t_{PZL}	\overline{OE}	B	$V_{CCB} = 1.2\text{ V}$	5	ns
			$V_{CCB} = 1.5\text{ V} \pm 0.1\text{ V}$	4.3	
			$V_{CCB} = 1.8\text{ V} \pm 0.15\text{ V}$	3.9	
			$V_{CCB} = 2.5\text{ V} \pm 0.2\text{ V}$	3.6	
			$V_{CCB} = 3.3\text{ V} \pm 0.3\text{ V}$	3.6	
t_{PHZ} , t_{PLZ}	\overline{OE}	A	$V_{CCB} = 1.2\text{ V}$	6.2	ns
			$V_{CCB} = 1.5\text{ V} \pm 0.1\text{ V}$	5.2	
			$V_{CCB} = 1.8\text{ V} \pm 0.15\text{ V}$	5.2	
			$V_{CCB} = 2.5\text{ V} \pm 0.2\text{ V}$	4.3	
			$V_{CCB} = 3.3\text{ V} \pm 0.3\text{ V}$	4.8	
t_{PHZ} , t_{PLZ}	\overline{OE}	B	$V_{CCB} = 1.2\text{ V}$	5.9	ns
			$V_{CCB} = 1.5\text{ V} \pm 0.1\text{ V}$	5.1	
			$V_{CCB} = 1.8\text{ V} \pm 0.15\text{ V}$	5	
			$V_{CCB} = 2.5\text{ V} \pm 0.2\text{ V}$	4.7	
			$V_{CCB} = 3.3\text{ V} \pm 0.3\text{ V}$	5.5	

6.7 Switching Characteristics, $V_{CCA} = 1.5\text{ V} \pm 0.1\text{ V}$

 over recommended operating ambient temperature range, $V_{CCA} = 1.5\text{ V} \pm 0.1\text{ V}$ (see [Figure 12](#))

PARAMETER	FROM (INPUT)	TO (OUTPUT)	V_{CCB}	MIN	TYP	MAX	UNIT
t_{PLH} , t_{PHL}	A	B	$V_{CCB} = 1.2\text{ V}$		3.2		ns
			$V_{CCB} = 1.5\text{ V} \pm 0.1\text{ V}$			11.3	
			$V_{CCB} = 1.8\text{ V} \pm 0.15\text{ V}$			10.2	
			$V_{CCB} = 2.5\text{ V} \pm 0.2\text{ V}$			9.2	
			$V_{CCB} = 3.3\text{ V} \pm 0.3\text{ V}$			9.2	
t_{PLH} , t_{PHL}	B	A	$V_{CCB} = 1.2\text{ V}$		3.3		ns
			$V_{CCB} = 1.5\text{ V} \pm 0.1\text{ V}$			11.3	
			$V_{CCB} = 1.8\text{ V} \pm 0.15\text{ V}$			11	
			$V_{CCB} = 2.5\text{ V} \pm 0.2\text{ V}$			10.7	
			$V_{CCB} = 3.3\text{ V} \pm 0.3\text{ V}$			10.6	
t_{PZH} , t_{PZL}	\overline{OE}	A	$V_{CCB} = 1.2\text{ V}$		4.9		ns
			$V_{CCB} = 1.5\text{ V} \pm 0.1\text{ V}$			14.6	
			$V_{CCB} = 1.8\text{ V} \pm 0.15\text{ V}$			14.5	
			$V_{CCB} = 2.5\text{ V} \pm 0.2\text{ V}$			14.4	
			$V_{CCB} = 3.3\text{ V} \pm 0.3\text{ V}$			14.4	
t_{PZH} , t_{PZL}	\overline{OE}	B	$V_{CCB} = 1.2\text{ V}$		4.5		ns
			$V_{CCB} = 1.5\text{ V} \pm 0.1\text{ V}$			14.6	
			$V_{CCB} = 1.8\text{ V} \pm 0.15\text{ V}$			12.7	
			$V_{CCB} = 2.5\text{ V} \pm 0.2\text{ V}$			10.8	
			$V_{CCB} = 3.3\text{ V} \pm 0.3\text{ V}$			10.6	
t_{PZH} , t_{PZL}	\overline{OE}	A	$V_{CCB} = 1.2\text{ V}$		5.6		ns
			$V_{CCB} = 1.5\text{ V} \pm 0.1\text{ V}$			15.2	
			$V_{CCB} = 1.8\text{ V} \pm 0.15\text{ V}$			15.2	
			$V_{CCB} = 2.5\text{ V} \pm 0.2\text{ V}$			15.2	
			$V_{CCB} = 3.3\text{ V} \pm 0.3\text{ V}$			15.2	
t_{PZH} , t_{PZL}	\overline{OE}	B	$V_{CCB} = 1.2\text{ V}$		5.2		ns
			$V_{CCB} = 1.5\text{ V} \pm 0.1\text{ V}$			15.3	
			$V_{CCB} = 1.8\text{ V} \pm 0.15\text{ V}$			14.1	
			$V_{CCB} = 2.5\text{ V} \pm 0.2\text{ V}$			12.4	
			$V_{CCB} = 3.3\text{ V} \pm 0.3\text{ V}$			12.6	

6.8 Switching Characteristics: $V_{CCA} = 1.8\text{ V} \pm 0.15\text{ V}$

 over recommended operating ambient temperature range, $V_{CCA} = 1.8\text{ V} \pm 0.15\text{ V}$ (see [Figure 12](#))

PARAMETER	FROM (INPUT)	TO (OUTPUT)	V_{CCB}	MIN	TYP	MAX	UNIT
t_{PLH} , t_{PHL}	A	B	$V_{CCB} = 1.2\text{ V}$		2.9		ns
			$V_{CCB} = 1.5\text{ V} \pm 0.1\text{ V}$			11	
			$V_{CCB} = 1.8\text{ V} \pm 0.15\text{ V}$			9.9	
			$V_{CCB} = 2.5\text{ V} \pm 0.2\text{ V}$			8.9	
			$V_{CCB} = 3.3\text{ V} \pm 0.3\text{ V}$			8.9	
t_{PLH} , t_{PHL}	B	A	$V_{CCB} = 1.2\text{ V}$		3		ns
			$V_{CCB} = 1.5\text{ V} \pm 0.1\text{ V}$			10.3	
			$V_{CCB} = 1.8\text{ V} \pm 0.15\text{ V}$			9.9	
			$V_{CCB} = 2.5\text{ V} \pm 0.2\text{ V}$			9.6	
			$V_{CCB} = 3.3\text{ V} \pm 0.3\text{ V}$			9.5	

Switching Characteristics: $V_{CCA} = 1.8\text{ V} \pm 0.15\text{ V}$ (continued)

 over recommended operating ambient temperature range, $V_{CCA} = 1.8\text{ V} \pm 0.15\text{ V}$ (see [Figure 12](#))

PARAMETER	FROM (INPUT)	TO (OUTPUT)	V_{CCB}	MIN	TYP	MAX	UNIT
t_{PZH}, t_{PZL}	\overline{OE}	A	$V_{CCB} = 1.2\text{ V}$		4.4		ns
			$V_{CCB} = 1.5\text{ V} \pm 0.1\text{ V}$			12.4	
			$V_{CCB} = 1.8\text{ V} \pm 0.15\text{ V}$			12.3	
			$V_{CCB} = 2.5\text{ V} \pm 0.2\text{ V}$			12.3	
			$V_{CCB} = 3.3\text{ V} \pm 0.3\text{ V}$			12.2	
t_{PZH}, t_{PZL}	\overline{OE}	B	$V_{CCB} = 1.2\text{ V}$		4.1		ns
			$V_{CCB} = 1.5\text{ V} \pm 0.1\text{ V}$			14.2	
			$V_{CCB} = 1.8\text{ V} \pm 0.15\text{ V}$			12.4	
			$V_{CCB} = 2.5\text{ V} \pm 0.2\text{ V}$			10.3	
			$V_{CCB} = 3.3\text{ V} \pm 0.3\text{ V}$			9.6	
t_{PZH}, t_{PZL}	\overline{OE}	A	$V_{CCB} = 1.2\text{ V}$		5.4		ns
			$V_{CCB} = 1.5\text{ V} \pm 0.1\text{ V}$			13.6	
			$V_{CCB} = 1.8\text{ V} \pm 0.15\text{ V}$			13.7	
			$V_{CCB} = 2.5\text{ V} \pm 0.2\text{ V}$			13.7	
			$V_{CCB} = 3.3\text{ V} \pm 0.3\text{ V}$			13.7	
t_{PZH}, t_{PZL}	\overline{OE}	B	$V_{CCB} = 1.2\text{ V}$		5		ns
			$V_{CCB} = 1.5\text{ V} \pm 0.1\text{ V}$			14.9	
			$V_{CCB} = 1.8\text{ V} \pm 0.15\text{ V}$			13.7	
			$V_{CCB} = 2.5\text{ V} \pm 0.2\text{ V}$			11.9	
			$V_{CCB} = 3.3\text{ V} \pm 0.3\text{ V}$			11.9	

6.9 Switching Characteristics: $V_{CCA} = 2.5\text{ V} \pm 0.2\text{ V}$

 over recommended operating ambient temperature range, $V_{CCA} = 2.5\text{ V} \pm 0.2\text{ V}$ (see [Figure 12](#))

PARAMETER	FROM (INPUT)	TO (OUTPUT)	V_{CCB}	MIN	TYP	MAX	UNIT
t_{PLH}, t_{PHL}	A	B	$V_{CCB} = 1.2\text{ V}$		2.8		ns
			$V_{CCB} = 1.5\text{ V} \pm 0.1\text{ V}$			10.7	
			$V_{CCB} = 1.8\text{ V} \pm 0.15\text{ V}$			9.6	
			$V_{CCB} = 2.5\text{ V} \pm 0.2\text{ V}$			8.5	
			$V_{CCB} = 3.3\text{ V} \pm 0.3\text{ V}$			8.6	
t_{PLH}, t_{PHL}	B	A	$V_{CCB} = 1.2\text{ V}$		2.7		ns
			$V_{CCB} = 1.5\text{ V} \pm 0.1\text{ V}$			9.2	
			$V_{CCB} = 1.8\text{ V} \pm 0.15\text{ V}$			8.9	
			$V_{CCB} = 2.5\text{ V} \pm 0.2\text{ V}$			8.4	
			$V_{CCB} = 3.3\text{ V} \pm 0.3\text{ V}$			8.3	
t_{PZH}, t_{PZL}	\overline{OE}	A	$V_{CCB} = 1.2\text{ V}$		4		ns
			$V_{CCB} = 1.5\text{ V} \pm 0.1\text{ V}$			11.5	
			$V_{CCB} = 1.8\text{ V} \pm 0.15\text{ V}$			10.2	
			$V_{CCB} = 2.5\text{ V} \pm 0.2\text{ V}$			9.8	
			$V_{CCB} = 3.3\text{ V} \pm 0.3\text{ V}$			9.8	
t_{PZH}, t_{PZL}	\overline{OE}	B	$V_{CCB} = 1.2\text{ V}$		3.8		ns
			$V_{CCB} = 1.5\text{ V} \pm 0.1\text{ V}$			13.8	
			$V_{CCB} = 1.8\text{ V} \pm 0.15\text{ V}$			12	
			$V_{CCB} = 2.5\text{ V} \pm 0.2\text{ V}$			9.8	
			$V_{CCB} = 3.3\text{ V} \pm 0.3\text{ V}$			9	

Switching Characteristics: $V_{CCA} = 2.5\text{ V} \pm 0.2\text{ V}$ (continued)

 over recommended operating ambient temperature range, $V_{CCA} = 2.5\text{ V} \pm 0.2\text{ V}$ (see [Figure 12](#))

PARAMETER	FROM (INPUT)	TO (OUTPUT)	V_{CCB}	MIN	TYP	MAX	UNIT
t_{PHZ} , t_{PLZ}	\overline{OE}	A	$V_{CCB} = 1.2\text{ V}$		4.7		ns
			$V_{CCB} = 1.5\text{ V} \pm 0.1\text{ V}$			13.4	
			$V_{CCB} = 1.8\text{ V} \pm 0.15\text{ V}$			13.4	
			$V_{CCB} = 2.5\text{ V} \pm 0.2\text{ V}$			11.2	
			$V_{CCB} = 3.3\text{ V} \pm 0.3\text{ V}$			11.5	
t_{PHZ} , t_{PLZ}	\overline{OE}	B	$V_{CCB} = 1.2\text{ V}$		4.5		ns
			$V_{CCB} = 1.5\text{ V} \pm 0.1\text{ V}$			14.4	
			$V_{CCB} = 1.8\text{ V} \pm 0.15\text{ V}$			13.2	
			$V_{CCB} = 2.5\text{ V} \pm 0.2\text{ V}$			11.2	
			$V_{CCB} = 3.3\text{ V} \pm 0.3\text{ V}$			10.2	

6.10 Switching Characteristics: $V_{CCA} = 3.3\text{ V} \pm 0.3\text{ V}$

 over recommended operating ambient temperature range, $V_{CCA} = 3.3\text{ V} \pm 0.3\text{ V}$ (see [Figure 12](#))

PARAMETER	FROM (INPUT)	TO (OUTPUT)	V_{CCB}	MIN	TYP	MAX	UNIT
t_{PLH} , t_{PHL}	A	B	$V_{CCB} = 1.2\text{ V}$		2.9		ns
			$V_{CCB} = 1.5\text{ V} \pm 0.1\text{ V}$			10.6	
			$V_{CCB} = 1.8\text{ V} \pm 0.15\text{ V}$			9.5	
			$V_{CCB} = 2.5\text{ V} \pm 0.2\text{ V}$			8.3	
			$V_{CCB} = 3.3\text{ V} \pm 0.3\text{ V}$			7.9	
t_{PLH} , t_{PHL}	B	A	$V_{CCB} = 1.2\text{ V}$		2.6		ns
			$V_{CCB} = 1.5\text{ V} \pm 0.1\text{ V}$			9.2	
			$V_{CCB} = 1.8\text{ V} \pm 0.15\text{ V}$			8.4	
			$V_{CCB} = 2.5\text{ V} \pm 0.2\text{ V}$			8	
			$V_{CCB} = 3.3\text{ V} \pm 0.3\text{ V}$			7.8	
t_{PHZ} , t_{PLZ}	\overline{OE}	A	$V_{CCB} = 1.2\text{ V}$		3.8		ns
			$V_{CCB} = 1.5\text{ V} \pm 0.1\text{ V}$			13.7	
			$V_{CCB} = 1.8\text{ V} \pm 0.15\text{ V}$			10.2	
			$V_{CCB} = 2.5\text{ V} \pm 0.2\text{ V}$			8.8	
			$V_{CCB} = 3.3\text{ V} \pm 0.3\text{ V}$			8.8	
t_{PHZ} , t_{PLZ}	\overline{OE}	B	$V_{CCB} = 1.2\text{ V}$		3.7		ns
			$V_{CCB} = 1.5\text{ V} \pm 0.1\text{ V}$			13.7	
			$V_{CCB} = 1.8\text{ V} \pm 0.15\text{ V}$			11.8	
			$V_{CCB} = 2.5\text{ V} \pm 0.2\text{ V}$			9.7	
			$V_{CCB} = 3.3\text{ V} \pm 0.3\text{ V}$			8.8	
t_{PHZ} , t_{PLZ}	\overline{OE}	A	$V_{CCB} = 1.2\text{ V}$		4.8		ns
			$V_{CCB} = 1.5\text{ V} \pm 0.1\text{ V}$			14.3	
			$V_{CCB} = 1.8\text{ V} \pm 0.15\text{ V}$			13.3	
			$V_{CCB} = 2.5\text{ V} \pm 0.2\text{ V}$			10.6	
			$V_{CCB} = 3.3\text{ V} \pm 0.3\text{ V}$			11.6	
t_{PHZ} , t_{PLZ}	\overline{OE}	B	$V_{CCB} = 1.2\text{ V}$		5.3		ns
			$V_{CCB} = 1.5\text{ V} \pm 0.1\text{ V}$			14.3	
			$V_{CCB} = 1.8\text{ V} \pm 0.15\text{ V}$			13.1	
			$V_{CCB} = 2.5\text{ V} \pm 0.2\text{ V}$			11.4	
			$V_{CCB} = 3.3\text{ V} \pm 0.3\text{ V}$			11.2	

6.11 Operating Characteristics

 $T_A = 25^\circ\text{C}$

PARAMETER		TEST CONDITIONS	V_{CCA}	TYP	UNIT	
$C_{pdA}^{(1)}$	A to B	Outputs enabled	$V_{CCA} = V_{CCB} = 1.2\text{ V}$	1	pF	
			$V_{CCA} = V_{CCB} = 1.5\text{ V}$	1		
			$V_{CCA} = V_{CCB} = 1.8\text{ V}$	1		
			$V_{CCA} = V_{CCB} = 2.5\text{ V}$	1.5		
			$V_{CCA} = V_{CCB} = 3.3\text{ V}$	2		
		Outputs disabled	$V_{CCA} = V_{CCB} = 1.2\text{ V}$	1		
			$V_{CCA} = V_{CCB} = 1.5\text{ V}$			
			$V_{CCA} = V_{CCB} = 1.8\text{ V}$			
			$V_{CCA} = V_{CCB} = 2.5\text{ V}$			
			$V_{CCA} = V_{CCB} = 3.3\text{ V}$			
	B to A	Outputs enabled	$C_L = 0,$ $f = 10\text{ MHz},$ $t_r = t_f = 1\text{ ns}$	$V_{CCA} = V_{CCB} = 1.2\text{ V}$		12
				$V_{CCA} = V_{CCB} = 1.5\text{ V}$		12.5
				$V_{CCA} = V_{CCB} = 1.8\text{ V}$		13
				$V_{CCA} = V_{CCB} = 2.5\text{ V}$		14
				$V_{CCA} = V_{CCB} = 3.3\text{ V}$		15
		Outputs disabled	$C_L = 0,$ $f = 10\text{ MHz},$ $t_r = t_f = 1\text{ ns}$	$V_{CCA} = V_{CCB} = 1.2\text{ V}$		1
				$V_{CCA} = V_{CCB} = 1.5\text{ V}$		
				$V_{CCA} = V_{CCB} = 1.8\text{ V}$		
				$V_{CCA} = V_{CCB} = 2.5\text{ V}$		
				$V_{CCA} = V_{CCB} = 3.3\text{ V}$		
$C_{pdB}^{(1)}$	A to B	Outputs enabled	$C_L = 0,$ $f = 10\text{ MHz},$ $t_r = t_f = 1\text{ ns}$	$V_{CCA} = V_{CCB} = 1.2\text{ V}$	12	
				$V_{CCA} = V_{CCB} = 1.5\text{ V}$	12.5	
				$V_{CCA} = V_{CCB} = 1.8\text{ V}$	13	
				$V_{CCA} = V_{CCB} = 2.5\text{ V}$	14	
				$V_{CCA} = V_{CCB} = 3.3\text{ V}$	15	
		Outputs disabled	$C_L = 0,$ $f = 10\text{ MHz},$ $t_r = t_f = 1\text{ ns}$	$V_{CCA} = V_{CCB} = 1.2\text{ V}$	1	
				$V_{CCA} = V_{CCB} = 1.5\text{ V}$		
				$V_{CCA} = V_{CCB} = 1.8\text{ V}$		
				$V_{CCA} = V_{CCB} = 2.5\text{ V}$		
				$V_{CCA} = V_{CCB} = 3.3\text{ V}$		
	B to A	Outputs enabled	$C_L = 0,$ $f = 10\text{ MHz},$ $t_r = t_f = 1\text{ ns}$	$V_{CCA} = V_{CCB} = 1.2\text{ V}$	1	
				$V_{CCA} = V_{CCB} = 1.5\text{ V}$	1	
				$V_{CCA} = V_{CCB} = 1.8\text{ V}$	1	
				$V_{CCA} = V_{CCB} = 2.5\text{ V}$	1	
				$V_{CCA} = V_{CCB} = 3.3\text{ V}$	2	
		Outputs disabled	$C_L = 0,$ $f = 10\text{ MHz},$ $t_r = t_f = 1\text{ ns}$	$V_{CCA} = V_{CCB} = 1.2\text{ V}$	1	
				$V_{CCA} = V_{CCB} = 1.5\text{ V}$		
				$V_{CCA} = V_{CCB} = 1.8\text{ V}$		
				$V_{CCA} = V_{CCB} = 2.5\text{ V}$		
				$V_{CCA} = V_{CCB} = 3.3\text{ V}$		

(1) Power dissipation capacitance per transceiver

6.12 Typical Characteristics

T_A = 25°C

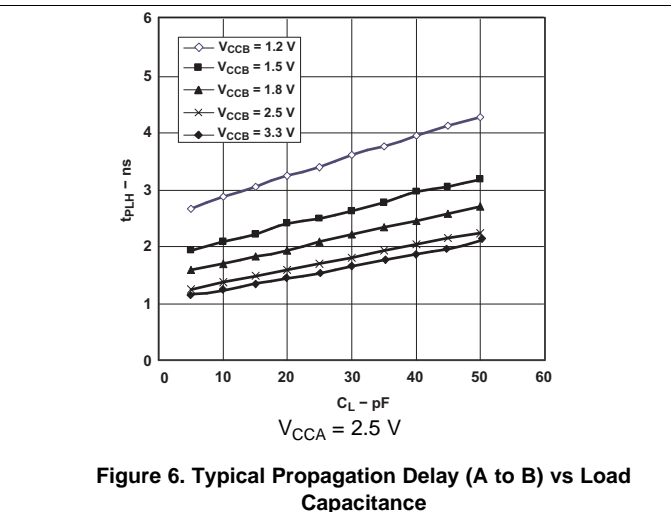
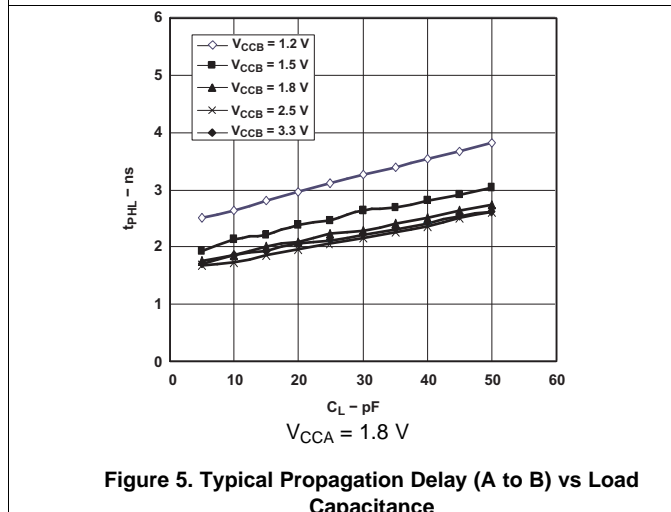
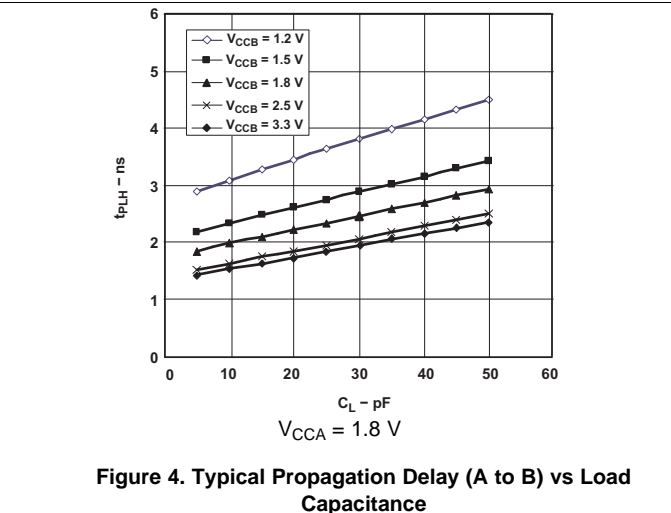
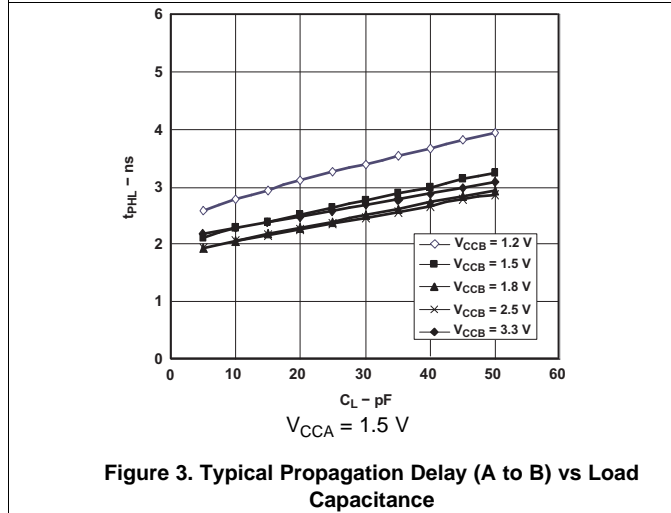
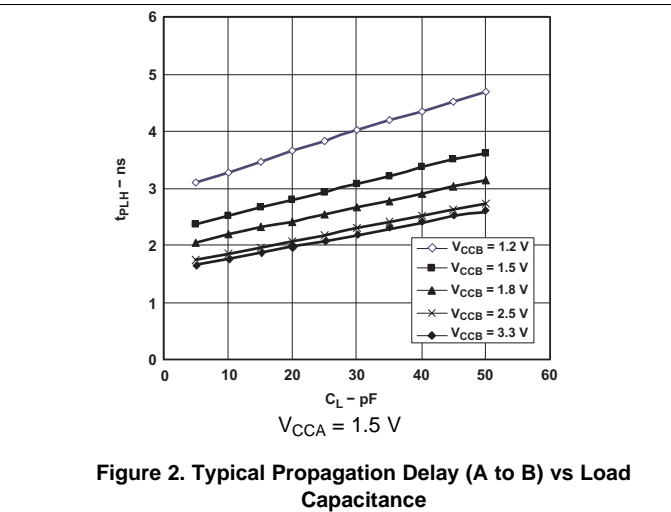
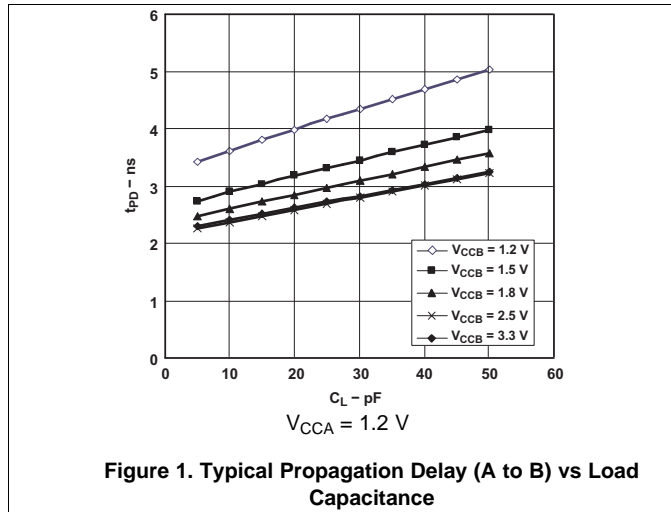

Typical Characteristics (continued)

T_A = 25°C

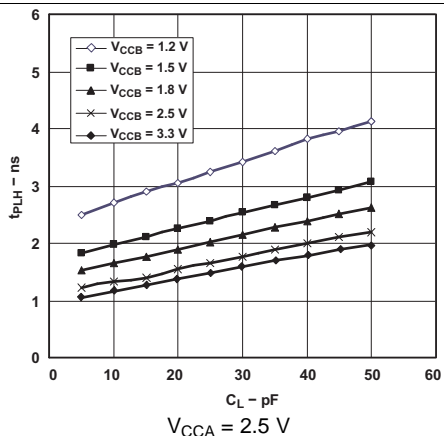

Figure 7. Typical Propagation Delay (A to B) vs Load Capacitance

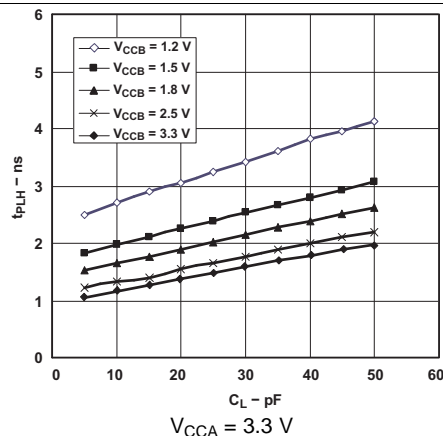

Figure 8. Typical Propagation Delay (A to B) vs Load Capacitance

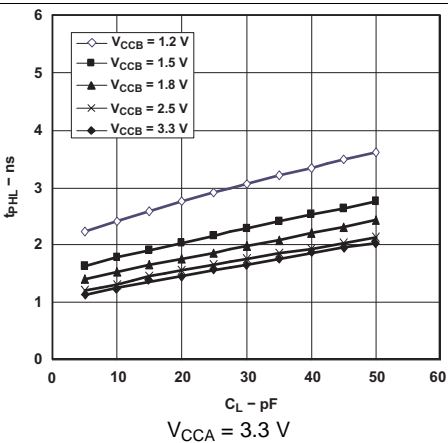

Figure 9. Typical Propagation Delay (A to B) vs Load Capacitance

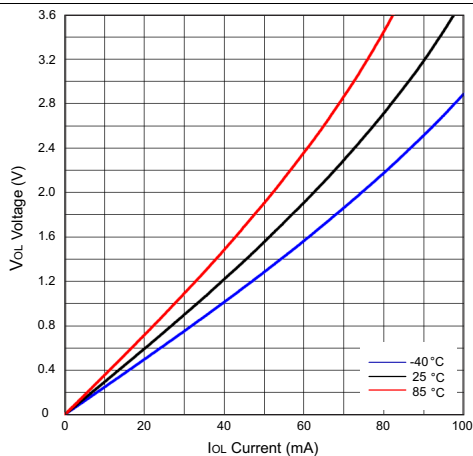

Figure 10. Low-Level Output Voltage (VOL) vs Low-Level Current (IOL)

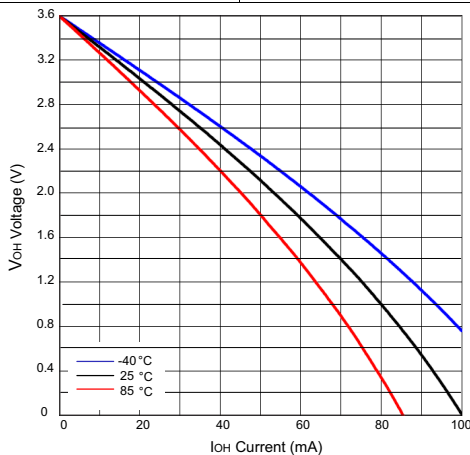
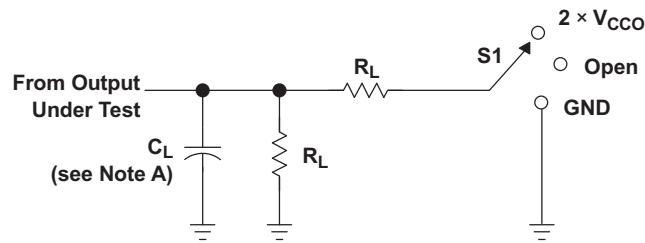

Figure 11. High-Level Output Voltage (VOH) vs High-Level Current (IOH)

7 Parameter Measurement Information

LOAD CIRCUIT

TEST	S1
t_{pd}	Open
t_{PLZ}/t_{PZL}	$2 \times V_{CCO}$
t_{PHZ}/t_{PZH}	GND

V_{CCO}	C_L	R_L	V_{TP}
1.2 V	15 pF	2 k Ω	0.1 V
1.5 V \pm 0.1 V	15 pF	2 k Ω	0.1 V
1.8 V \pm 0.15 V	15 pF	2 k Ω	0.15 V
2.5 V \pm 0.2 V	15 pF	2 k Ω	0.15 V
3.3 V \pm 0.3 V	15 pF	2 k Ω	0.3 V

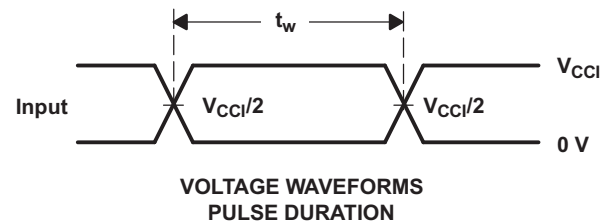
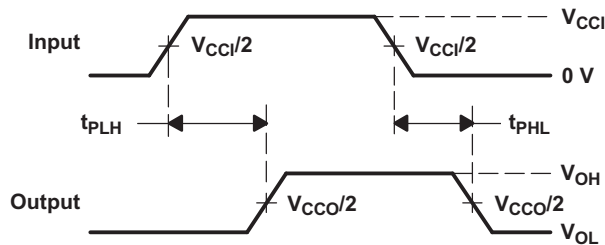
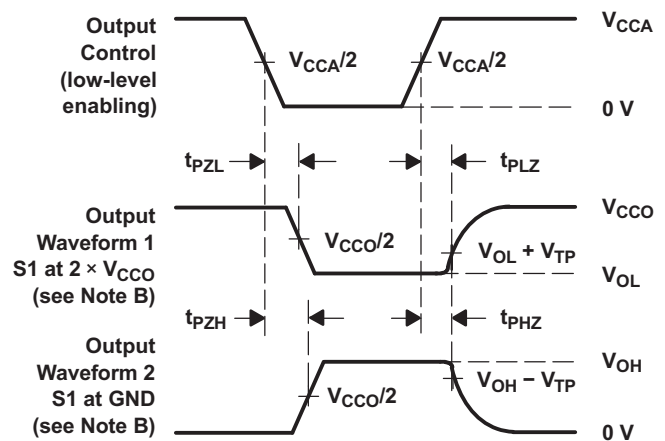
**VOLTAGE WAVEFORMS
PULSE DURATION**

**VOLTAGE WAVEFORMS
PROPAGATION DELAY TIMES**

**VOLTAGE WAVEFORMS
ENABLE AND DISABLE TIMES**

- NOTES:
- C_L includes probe and jig capacitance.
 - Waveform 1 is for an output with internal conditions such that the output is low except when disabled by the output control. Waveform 2 is for an output with internal conditions such that the output is high, except when disabled by the output control.
 - All input pulses are supplied by generators having the following characteristics: PRR \leq 10 MHz, $Z_O = 50 \Omega$, $dv/dt \geq 1$ V/ns.
 - The outputs are measured one at a time, with one transition per measurement.
 - t_{PLZ} and t_{PHZ} are the same as t_{dis} .
 - t_{PZL} and t_{PZH} are the same as t_{en} .
 - t_{PLH} and t_{PHL} are the same as t_{pd} .
 - V_{CCI} is the V_{CC} associated with the input port.
 - V_{CCO} is the V_{CC} associated with the output port.

Figure 12. Load and Circuit and Voltage Waveforms

8 Detailed Description

8.1 Overview

The SN74AVC4T245-Q1 is a 4-bit, dual-supply noninverting bidirectional voltage level translation device. Ax pins and control pins (1DIR, 2DIR, $\overline{1OE}$, and $\overline{2OE}$) are supported by V_{CCA} , and Bx pins are supported by V_{CCB} . The A port is able to accept I/O voltages ranging from 1.2 V to 3.6 V, while the B port can accept I/O voltages from 1.2 V to 3.6 V. A high on DIR allows data transmission from Ax to Bx and a low on DIR allows data transmission from Bx to Ax when \overline{OE} is set to low. When \overline{OE} is set to high, both Ax and Bx pins are in the high-impedance state.

8.2 Functional Block Diagram

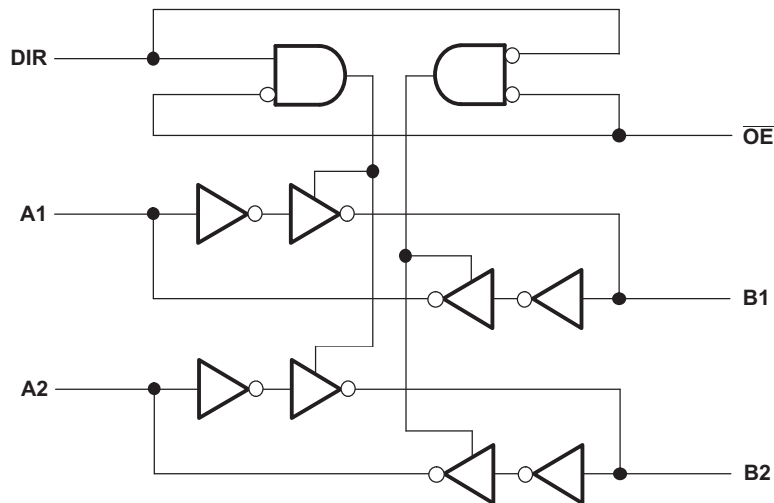

Figure 13. Logic Diagram (Positive Logic) for 1/2 of SN74AVC4T245-Q1

8.3 Feature Description

8.3.1 Fully Configurable Dual-Rail Design

Both V_{CCA} and V_{CCB} can be supplied at any voltage between 1.2 V and 3.6 V; thus, making the device suitable for translating between any of the low voltage nodes (1.2 V, 1.8 V, 2.5 V, and 3.3 V).

8.3.2 Supports High Speed Translation

The SN74AVC4T245-Q1 device can support high data rate applications. The translated signal data rate can be up to 380 Mbps when the signal is translated from 1.8 V to 3.3 V.

8.3.3 I_{off} Supports Partial-Power-Down Mode Operation

I_{off} prevents backflow current by disabling I/O output circuits when the device is in partial-power-down mode.

8.4 Device Functional Modes

Table 1 lists the functional modes of the SN74AVC4T245-Q1 device.

**Table 1. Function Table
(Each 2-Bit Section)⁽¹⁾**

CONTROL INPUTS		OUTPUT CIRCUITS		OPERATION
\overline{OE}	DIR	A PORT	B PORT	
L	L	Enabled	Hi-Z	B data to A bus
L	H	Hi-Z	Enabled	A data to B bus
H	X	Hi-Z	Hi-Z	Isolation

(1) Input circuits of the data I/Os are always active.

9 Application and Implementation

NOTE

Information in the following applications sections is not part of the TI component specification, and TI does not warrant its accuracy or completeness. TI's customers are responsible for determining suitability of components for their purposes. Customers should validate and test their design implementation to confirm system functionality.

9.1 Application Information

The SN74AVC4T245-Q1 device can be used in level-translation applications for interfacing devices or systems operating at different interface voltages with one another. The SN74AVC4T245-Q1 device is ideal for use in applications where a push-pull driver is connected to the data I/Os. The maximum data rate can be up to 380 Mbps when the device translates a signal from 1.8 V to 3.3 V.

9.2 Typical Application

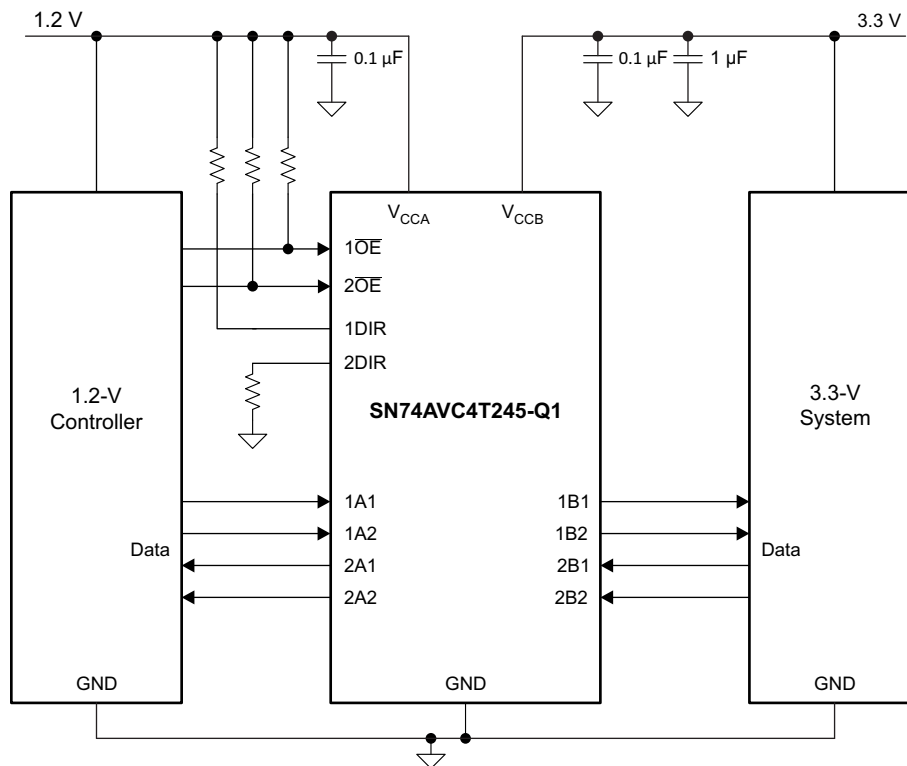

Figure 14. Typical Application Diagram

Typical Application (continued)

9.2.1 Design Requirements

Table 2 lists the parameters for this design example.

Table 2. Design Parameters

DESIGN PARAMETER	EXAMPLE VALUE
Input voltage range	1.2 V
Output voltage range	3.3 V

9.2.2 Detailed Design Procedure

To begin the design process, determine the following:

- Input voltage range
 - Use the supply voltage of the device that is driving the SN74AVC4T245-Q1 device to determine the input voltage range. For a valid logic high, the value must exceed the V_{IH} of the input port. For a valid logic low, the value must be less than the V_{IL} of the input port. For this example, the input voltage is 1.2 V.
- Output voltage range
 - Use the supply voltage of the device that the SN74AVC4T245-Q1 device is driving to determine the output voltage range. For this example, the output voltage is 3.3 V.

9.2.3 Application Curve

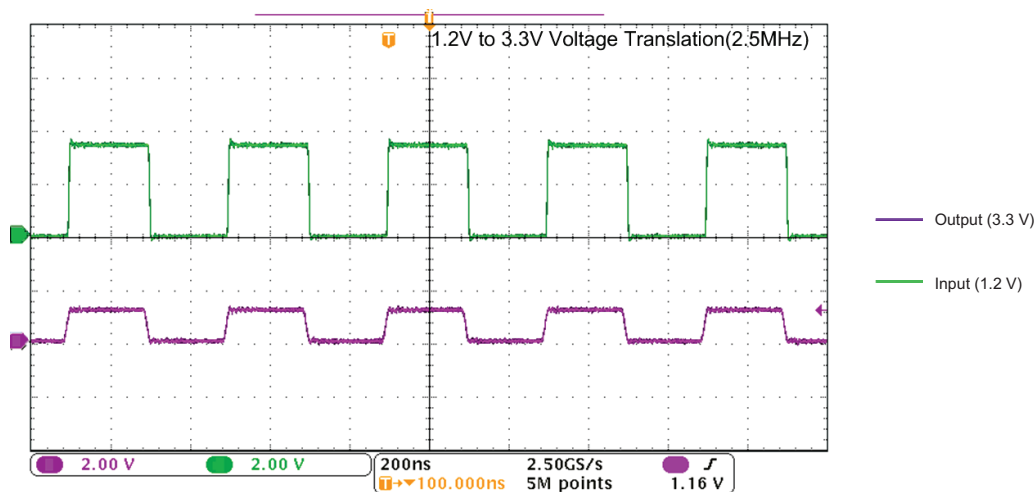

Figure 15. Translation Up (1.2 V to 3.3 V) at 2.5 MHz

10 Power Supply Recommendations

The SN74AVC4T245-Q1 device uses two separate configurable power-supply rails: V_{CCA} and V_{CCB} . V_{CCA} accepts any supply voltage from 1.2 V to 3.6 V, and V_{CCB} accepts any supply voltage from 1.2 V to 3.6 V. The A port and B port are designed to track V_{CCA} and V_{CCB} respectively, allowing for low-voltage bidirectional translation between any of the 1.2-V, 1.5-V, 1.8-V, 2.5-V, and 3.3-V voltage nodes.

The output-enable (\overline{OE}) input circuit is designed so that it is supplied by V_{CCA} ; when the \overline{OE} input is high, all outputs are placed in the high-impedance state. To ensure the high-impedance state of the outputs during power up or power down, the \overline{OE} input pin must be tied to V_{CCA} through a pullup resistor and must not be enabled until V_{CCA} and V_{CCB} are fully ramped and stable. The minimum value of the pullup resistor to V_{CCA} is determined by the current-sinking capability of the driver.

11 Layout

11.1 Layout Guidelines

To ensure reliability of the device, following common printed-circuit board layout guidelines is recommended.

- Bypass capacitors should be used on power supplies.
- Short trace lengths should be used to avoid excessive loading.
- Place pads on the signal paths for loading capacitors or pullup resistors to help adjust rise and fall times of signals, depending on the system requirements.

11.2 Layout Example

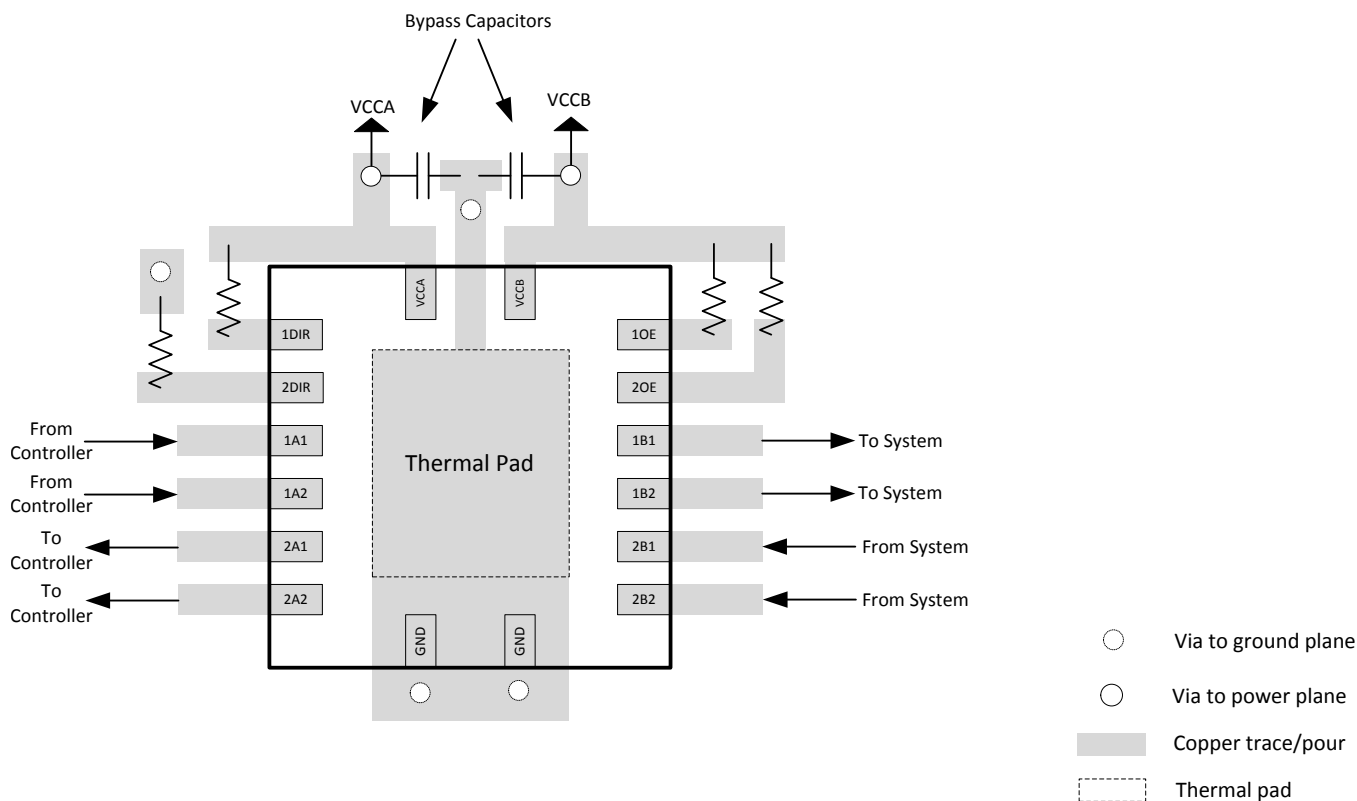

Figure 16. SN74AVC4T245-Q1 RGY Package Layout Diagram

12 Device and Documentation Support

12.1 Documentation Support

12.1.1 Related Documentation

- *IC Package Thermal Metrics* application report ([SPRA953](#))
- *Implications of Slow or Floating CMOS Inputs* application report ([SCBA004](#))

The following links connect to TI community resources. Linked contents are provided "AS IS" by the respective contributors. They do not constitute TI specifications and do not necessarily reflect TI's views; see TI's [Terms of Use](#).

TI E2E™ Online Community *TI's Engineer-to-Engineer (E2E) Community*. Created to foster collaboration among engineers. At [e2e.ti.com](#), you can ask questions, share knowledge, explore ideas and help solve problems with fellow engineers.

Design Support *TI's Design Support* Quickly find helpful E2E forums along with design support tools and contact information for technical support.

12.2 Trademarks

E2E is a trademark of Texas Instruments.
All other trademarks are the property of their respective owners.

12.3 Electrostatic Discharge Caution



These devices have limited built-in ESD protection. The leads should be shorted together or the device placed in conductive foam during storage or handling to prevent electrostatic damage to the MOS gates.

12.4 Glossary

[SLYZ022](#) — *TI Glossary*.

This glossary lists and explains terms, acronyms, and definitions.

13 Mechanical, Packaging, and Orderable Information

The following pages include mechanical, packaging, and orderable information. This information is the most-current data available for the designated device. This data is subject to change without notice and without revision of this document. For browser-based versions of this data sheet, see the left-hand navigation pane.

PACKAGING INFORMATION

Orderable Device	Status (1)	Package Type	Package Drawing	Pins	Package Qty	Eco Plan (2)	Lead/Ball Finish (6)	MSL Peak Temp (3)	Op Temp (°C)	Device Marking (4/5)	Samples
74AVC4T245QRGYRQ1	ACTIVE	VQFN	RGY	16	3000	Green (RoHS & no Sb/Br)	CU NIPDAU	Level-3-260C-168 HR	-40 to 125	4T245Q	Samples

(1) The marketing status values are defined as follows:

ACTIVE: Product device recommended for new designs.

LIFEBUY: TI has announced that the device will be discontinued, and a lifetime-buy period is in effect.

NRND: Not recommended for new designs. Device is in production to support existing customers, but TI does not recommend using this part in a new design.

PREVIEW: Device has been announced but is not in production. Samples may or may not be available.

OBSELETE: TI has discontinued the production of the device.

(2) Eco Plan - The planned eco-friendly classification: Pb-Free (RoHS), Pb-Free (RoHS Exempt), or Green (RoHS & no Sb/Br) - please check <http://www.ti.com/productcontent> for the latest availability information and additional product content details.

TBD: The Pb-Free/Green conversion plan has not been defined.

Pb-Free (RoHS): TI's terms "Lead-Free" or "Pb-Free" mean semiconductor products that are compatible with the current RoHS requirements for all 6 substances, including the requirement that lead not exceed 0.1% by weight in homogeneous materials. Where designed to be soldered at high temperatures, TI Pb-Free products are suitable for use in specified lead-free processes.

Pb-Free (RoHS Exempt): This component has a RoHS exemption for either 1) lead-based flip-chip solder bumps used between the die and package, or 2) lead-based die adhesive used between the die and leadframe. The component is otherwise considered Pb-Free (RoHS compatible) as defined above.

Green (RoHS & no Sb/Br): TI defines "Green" to mean Pb-Free (RoHS compatible), and free of Bromine (Br) and Antimony (Sb) based flame retardants (Br or Sb do not exceed 0.1% by weight in homogeneous material)

(3) MSL, Peak Temp. - The Moisture Sensitivity Level rating according to the JEDEC industry standard classifications, and peak solder temperature.

(4) There may be additional marking, which relates to the logo, the lot trace code information, or the environmental category on the device.

(5) Multiple Device Markings will be inside parentheses. Only one Device Marking contained in parentheses and separated by a "~" will appear on a device. If a line is indented then it is a continuation of the previous line and the two combined represent the entire Device Marking for that device.

(6) Lead/Ball Finish - Orderable Devices may have multiple material finish options. Finish options are separated by a vertical ruled line. Lead/Ball Finish values may wrap to two lines if the finish value exceeds the maximum column width.

Important Information and Disclaimer:The information provided on this page represents TI's knowledge and belief as of the date that it is provided. TI bases its knowledge and belief on information provided by third parties, and makes no representation or warranty as to the accuracy of such information. Efforts are underway to better integrate information from third parties. TI has taken and continues to take reasonable steps to provide representative and accurate information but may not have conducted destructive testing or chemical analysis on incoming materials and chemicals. TI and TI suppliers consider certain information to be proprietary, and thus CAS numbers and other limited information may not be available for release.

In no event shall TI's liability arising out of such information exceed the total purchase price of the TI part(s) at issue in this document sold by TI to Customer on an annual basis.

OTHER QUALIFIED VERSIONS OF SN74AVC4T245-Q1 :

- Catalog: [SN74AVC4T245](#)

NOTE: Qualified Version Definitions:

- Catalog - TI's standard catalog product

TAPE AND REEL INFORMATION

QUADRANT ASSIGNMENTS FOR PIN 1 ORIENTATION IN TAPE

*All dimensions are nominal

Device	Package Type	Package Drawing	Pins	SPQ	Reel Diameter (mm)	Reel Width W1 (mm)	A0 (mm)	B0 (mm)	K0 (mm)	P1 (mm)	W (mm)	Pin1 Quadrant
74AVC4T245QRGYRQ1	VQFN	RGY	16	3000	330.0	12.4	3.8	4.3	1.5	8.0	12.0	Q1

TAPE AND REEL BOX DIMENSIONS



*All dimensions are nominal

Device	Package Type	Package Drawing	Pins	SPQ	Length (mm)	Width (mm)	Height (mm)
74AVC4T245QRGYRQ1	VQFN	RGY	16	3000	367.0	367.0	35.0

RGY (R-PVQFN-N16)

PLASTIC QUAD FLATPACK NO-LEAD

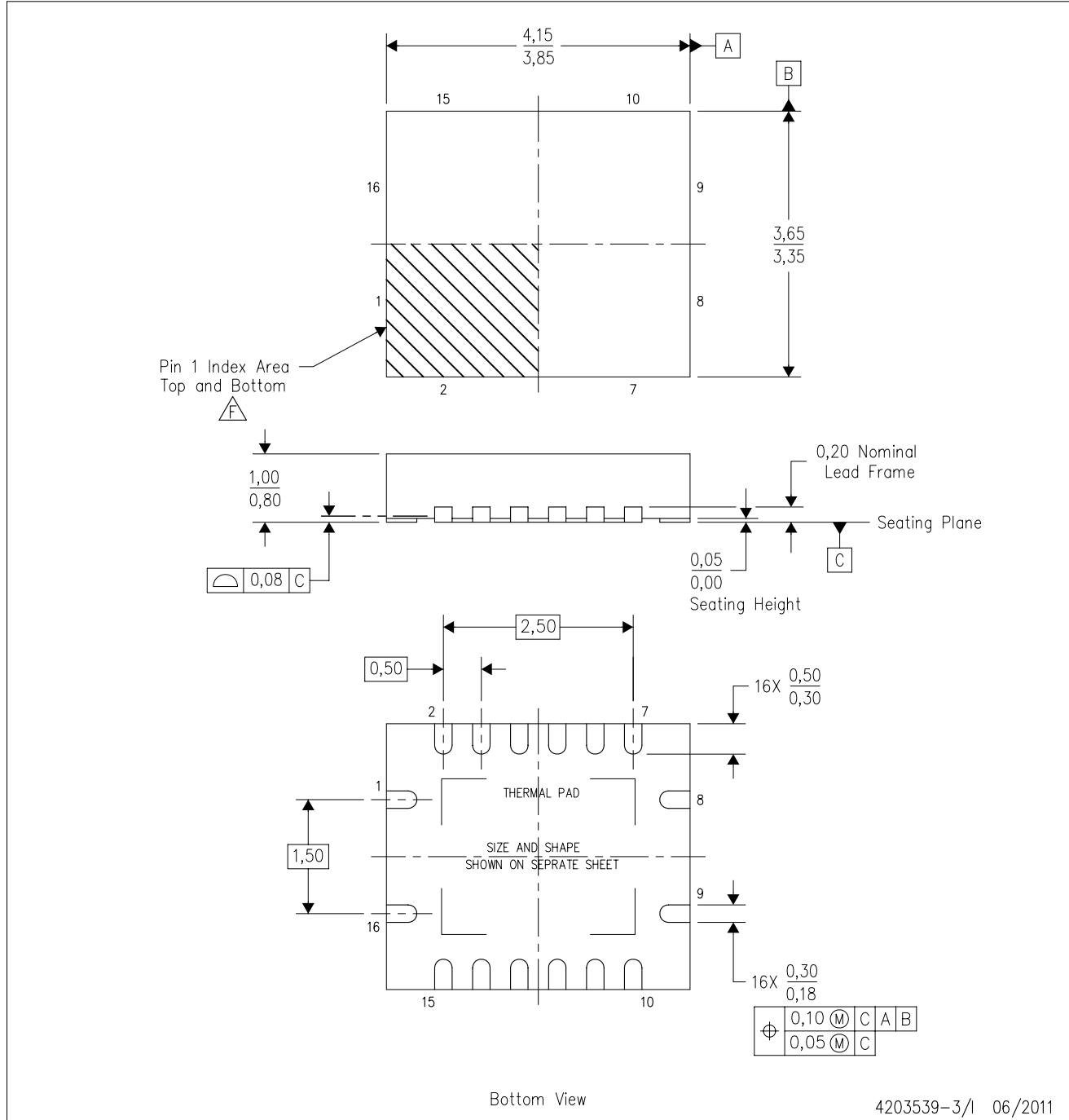

4203539-3/1 06/2011

- NOTES:
- All linear dimensions are in millimeters. Dimensioning and tolerancing per ASME Y14.5M-1994.
 - This drawing is subject to change without notice.
 - QFN (Quad Flatpack No-Lead) package configuration.
 - The package thermal pad must be soldered to the board for thermal and mechanical performance.
 - See the additional figure in the Product Data Sheet for details regarding the exposed thermal pad features and dimensions.
 - Pin 1 identifiers are located on both top and bottom of the package and within the zone indicated. The Pin 1 identifiers are either a molded, marked, or metal feature.
 - Package complies to JEDEC MO-241 variation BA.

RGY (R-PVQFN-N16)

PLASTIC QUAD FLATPACK NO-LEAD

THERMAL INFORMATION

This package incorporates an exposed thermal pad that is designed to be attached directly to an external heatsink. The thermal pad must be soldered directly to the printed circuit board (PCB). After soldering, the PCB can be used as a heatsink. In addition, through the use of thermal vias, the thermal pad can be attached directly to the appropriate copper plane shown in the electrical schematic for the device, or alternatively, can be attached to a special heatsink structure designed into the PCB. This design optimizes the heat transfer from the integrated circuit (IC).

For information on the Quad Flatpack No-Lead (QFN) package and its advantages, refer to Application Report, QFN/SON PCB Attachment, Texas Instruments Literature No. SLUA271. This document is available at www.ti.com.

The exposed thermal pad dimensions for this package are shown in the following illustration.



Bottom View

Exposed Thermal Pad Dimensions

4206353-3/P 03/14

NOTE: All linear dimensions are in millimeters

RGY (R-PVQFN-N16)

PLASTIC QUAD FLATPACK NO-LEAD



4208122-3/P 03/14

- NOTES:
- A. All linear dimensions are in millimeters.
 - B. This drawing is subject to change without notice.
 - C. Publication IPC-7351 is recommended for alternate designs.
 - D. This package is designed to be soldered to a thermal pad on the board. Refer to Application Note, Quad Flat-Pack QFN/SON PCB Attachment, Texas Instruments Literature No. SLUA271, and also the Product Data Sheets for specific thermal information, via requirements, and recommended board layout. These documents are available at www.ti.com <<http://www.ti.com>>.
 - E. Laser cutting apertures with trapezoidal walls and also rounding corners will offer better paste release. Customers should contact their board assembly site for stencil design recommendations. Refer to IPC 7525 for stencil design considerations.
 - F. Customers should contact their board fabrication site for minimum solder mask web tolerances between signal pads.

IMPORTANT NOTICE

Texas Instruments Incorporated and its subsidiaries (TI) reserve the right to make corrections, enhancements, improvements and other changes to its semiconductor products and services per JESD46, latest issue, and to discontinue any product or service per JESD48, latest issue. Buyers should obtain the latest relevant information before placing orders and should verify that such information is current and complete. All semiconductor products (also referred to herein as "components") are sold subject to TI's terms and conditions of sale supplied at the time of order acknowledgment.

TI warrants performance of its components to the specifications applicable at the time of sale, in accordance with the warranty in TI's terms and conditions of sale of semiconductor products. Testing and other quality control techniques are used to the extent TI deems necessary to support this warranty. Except where mandated by applicable law, testing of all parameters of each component is not necessarily performed.

TI assumes no liability for applications assistance or the design of Buyers' products. Buyers are responsible for their products and applications using TI components. To minimize the risks associated with Buyers' products and applications, Buyers should provide adequate design and operating safeguards.

TI does not warrant or represent that any license, either express or implied, is granted under any patent right, copyright, mask work right, or other intellectual property right relating to any combination, machine, or process in which TI components or services are used. Information published by TI regarding third-party products or services does not constitute a license to use such products or services or a warranty or endorsement thereof. Use of such information may require a license from a third party under the patents or other intellectual property of the third party, or a license from TI under the patents or other intellectual property of TI.

Reproduction of significant portions of TI information in TI data books or data sheets is permissible only if reproduction is without alteration and is accompanied by all associated warranties, conditions, limitations, and notices. TI is not responsible or liable for such altered documentation. Information of third parties may be subject to additional restrictions.

Resale of TI components or services with statements different from or beyond the parameters stated by TI for that component or service voids all express and any implied warranties for the associated TI component or service and is an unfair and deceptive business practice. TI is not responsible or liable for any such statements.

Buyer acknowledges and agrees that it is solely responsible for compliance with all legal, regulatory and safety-related requirements concerning its products, and any use of TI components in its applications, notwithstanding any applications-related information or support that may be provided by TI. Buyer represents and agrees that it has all the necessary expertise to create and implement safeguards which anticipate dangerous consequences of failures, monitor failures and their consequences, lessen the likelihood of failures that might cause harm and take appropriate remedial actions. Buyer will fully indemnify TI and its representatives against any damages arising out of the use of any TI components in safety-critical applications.

In some cases, TI components may be promoted specifically to facilitate safety-related applications. With such components, TI's goal is to help enable customers to design and create their own end-product solutions that meet applicable functional safety standards and requirements. Nonetheless, such components are subject to these terms.

No TI components are authorized for use in FDA Class III (or similar life-critical medical equipment) unless authorized officers of the parties have executed a special agreement specifically governing such use.

Only those TI components which TI has specifically designated as military grade or "enhanced plastic" are designed and intended for use in military/aerospace applications or environments. Buyer acknowledges and agrees that any military or aerospace use of TI components which have **not** been so designated is solely at the Buyer's risk, and that Buyer is solely responsible for compliance with all legal and regulatory requirements in connection with such use.

TI has specifically designated certain components as meeting ISO/TS16949 requirements, mainly for automotive use. In any case of use of non-designated products, TI will not be responsible for any failure to meet ISO/TS16949.

Products

Audio	www.ti.com/audio
Amplifiers	amplifier.ti.com
Data Converters	dataconverter.ti.com
DLP® Products	www.dlp.com
DSP	dsp.ti.com
Clocks and Timers	www.ti.com/clocks
Interface	interface.ti.com
Logic	logic.ti.com
Power Mgmt	power.ti.com
Microcontrollers	microcontroller.ti.com
RFID	www.ti-rfid.com
OMAP Applications Processors	www.ti.com/omap
Wireless Connectivity	www.ti.com/wirelessconnectivity

Applications

Automotive and Transportation	www.ti.com/automotive
Communications and Telecom	www.ti.com/communications
Computers and Peripherals	www.ti.com/computers
Consumer Electronics	www.ti.com/consumer-apps
Energy and Lighting	www.ti.com/energy
Industrial	www.ti.com/industrial
Medical	www.ti.com/medical
Security	www.ti.com/security
Space, Avionics and Defense	www.ti.com/space-avionics-defense
Video and Imaging	www.ti.com/video

TI E2E Community

e2e.ti.com

Looking for pricing, stock, or lifecycle information?

Click below to explore more details on WIN SOURCE:

 [View 74AVC4T245QRGYRQ1](#) on WIN SOURCE

 [Texas Instruments](#) Information

Optimize Your Supply Chain with WIN SOURCE Solutions

-  Global Sourcing Solution
-  Obsolete Management
-  Cost Control Management
-  Shortage Management
-  Alternative Solution
-  Excess Inventory Management