



**THE DATASHEET OF
74AVC16834ADGV,118**



Important notice

Dear Customer,

On 7 February 2017 the former NXP Standard Product business became a new company with the tradename **Nexperia**. Nexperia is an industry leading supplier of Discrete, Logic and PowerMOS semiconductors with its focus on the automotive, industrial, computing, consumer and wearable application markets

In data sheets and application notes which still contain NXP or Philips Semiconductors references, use the references to Nexperia, as shown below.

Instead of <http://www.nxp.com>, <http://www.philips.com/> or <http://www.semiconductors.philips.com/>, use <http://www.nexperia.com>

Instead of sales.addresses@www.nxp.com or sales.addresses@www.semiconductors.philips.com, use salesaddresses@nexperia.com (email)

Replace the copyright notice at the bottom of each page or elsewhere in the document, depending on the version, as shown below:

- © NXP N.V. (year). All rights reserved or © Koninklijke Philips Electronics N.V. (year). All rights reserved

Should be replaced with:

- © **Nexperia B.V. (year). All rights reserved.**

If you have any questions related to the data sheet, please contact our nearest sales office via e-mail or telephone (details via salesaddresses@nexperia.com). Thank you for your cooperation and understanding,

Kind regards,

Team Nexperia

DATA SHEET

74AVC16834A

18-bit registered driver
with inverted register enable and
Dynamic Controlled Outputs™ (3-State)

Product data
Supersedes data of 2000 Jul 25

2002 Sep 11

18-bit registered driver with inverted register enable and Dynamic Controlled Outputs™ (3-State)

74AVC16834A

FEATURES

- Wide supply voltage range of 1.2 V to 3.6 V
- Complies with JEDEC standard no. 8-1A/5/7
- CMOS low power consumption
- Input/output tolerant up to 3.6 V
- DCO (Dynamic Controlled Output) circuit dynamically changes output impedance, resulting in noise reduction without speed degradation
- Low inductance multiple V_{CC} and GND pins for minimum noise and ground bounce
- Power off disables 74AVC16834A outputs, permitting Live Insertion
- Integrated input diodes to minimize input overshoot and undershoot
- Full PC133 solution provided when used with PCK2509S or PCK2510S and CBT16292

DESCRIPTION

The 74AVC16834A is a 18-bit universal bus driver. Data flow is controlled by output enable (\overline{OE}), latch enable (\overline{LE}) and clock inputs (CP).

This product is designed to have an extremely fast propagation delay and a minimum amount of power consumption.

To ensure the high-impedance state during power up or power down, \overline{OE} should be tied to V_{CC} through a pullup resistor (Live Insertion).

A Dynamic Controlled Output (DCO) circuitry is implemented to support termination line drive during transient. See the graphs on page 9 for typical curves.

PIN CONFIGURATION

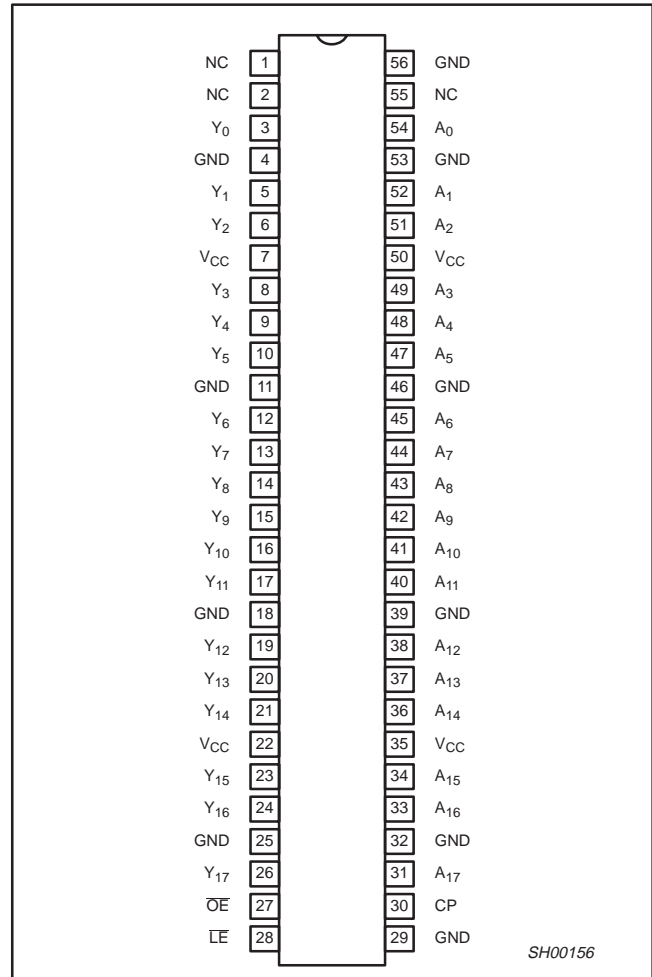

SH00156

QUICK REFERENCE DATA

$GND = 0 V$; $T_{amb} = 25\text{ }^{\circ}C$; $t_r = t_f \leq 2.0\text{ ns}$; $C_L = 30\text{ pF}$.

SYMBOL	PARAMETER	CONDITIONS	TYPICAL	UNIT
t_{PHL}/t_{PLH}	Propagation delay An to Yn	$V_{CC} = 1.8\text{ V}$ $V_{CC} = 2.5\text{ V}$ $V_{CC} = 3.3\text{ V}$	2.6 2.0 1.7	ns
t_{PHL}/t_{PLH}	Propagation delay LE to Yn; CP to Yn	$V_{CC} = 1.8\text{ V}$ $V_{CC} = 2.5\text{ V}$ $V_{CC} = 3.3\text{ V}$	2.9 2.3 1.9	ns
C_I	Input capacitance		5.0	pF
C_{PD}	Power dissipation capacitance per buffer	$V_I = GND\text{ to }V_{CC}^1$	Outputs enabled 25 Output disabled 6	pF

NOTES:

- C_{PD} is used to determine the dynamic power dissipation (P_D in μW):

$$P_D = C_{PD} \times V_{CC}^2 \times f_i + \sum (C_L \times V_{CC}^2 \times f_o)$$
 where: f_i = input frequency in MHz; C_L = output load capacitance in pF;
 f_o = output frequency in MHz; V_{CC} = supply voltage in V; $\sum (C_L \times V_{CC}^2 \times f_o)$ = sum of outputs.

ORDERING INFORMATION

PACKAGES	TEMPERATURE RANGE	ORDER CODE	DRAWING NUMBER
56-Pin Plastic 0.5 mm pitch TSSOP	$-40^{\circ}C$ to $+85^{\circ}C$	74AVC16834ADGG	SOT364-1
56-Pin Plastic 0.4 pitch TSSOP (TVSOP)	$-40^{\circ}C$ to $+85^{\circ}C$	74AVC16834ADGV	SOT481-2

18-bit registered driver with inverted register enable and Dynamic Controlled Outputs™ (3-State)

74AVC16834A

PIN DESCRIPTION

PIN NUMBER	SYMBOL	NAME AND FUNCTION
1, 2, 55	NC	No connection
3, 5, 6, 8, 9, 10, 12, 13, 14, 15, 16, 17, 19, 20, 21, 23, 24, 26	Y ₀ to Y ₁₇	Data outputs
4, 11, 18, 25, 32, 39, 46, 53, 56	GND	Ground (0 V)
7, 22, 35, 50	V _{CC}	Positive supply voltage
27	\overline{OE}	Output enable input (active LOW)
28	\overline{LE}	Latch enable input (active LOW)
30	CP	Clock input
54, 52, 51, 49, 48, 47, 45, 44, 43, 42, 41, 40, 38, 37, 36, 34, 33, 31	A ₀ to A ₁₇	Data inputs

LOGIC SYMBOL

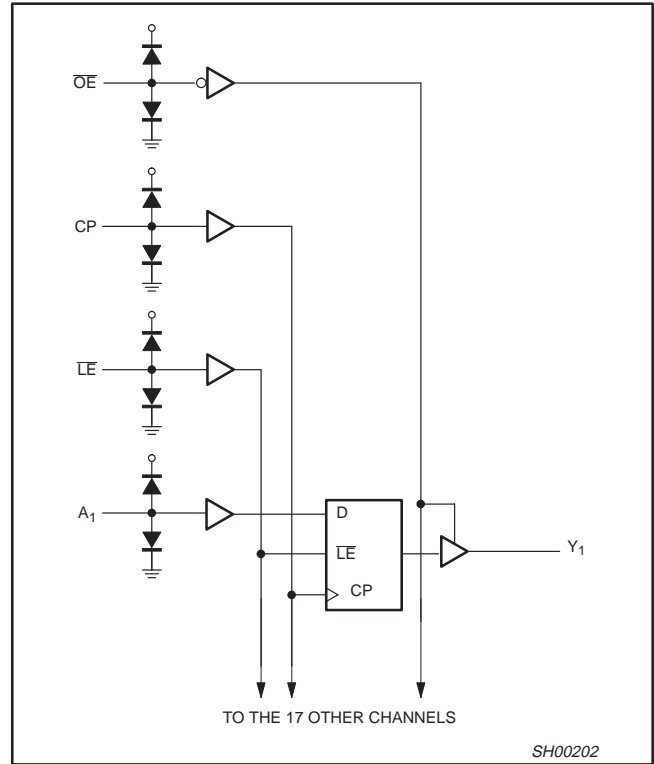

TYPICAL INPUT (DATA OR CONTROL)

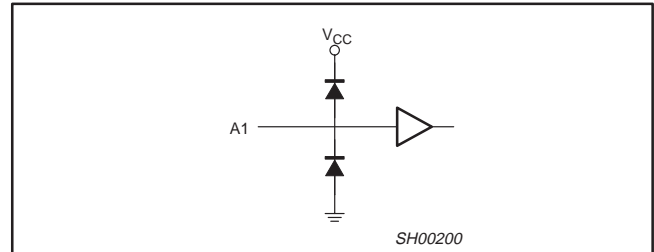

18-bit registered driver with inverted register enable and Dynamic Controlled Outputs™ (3-State)

74AVC16834A

LOGIC SYMBOL (IEEE/IEC)

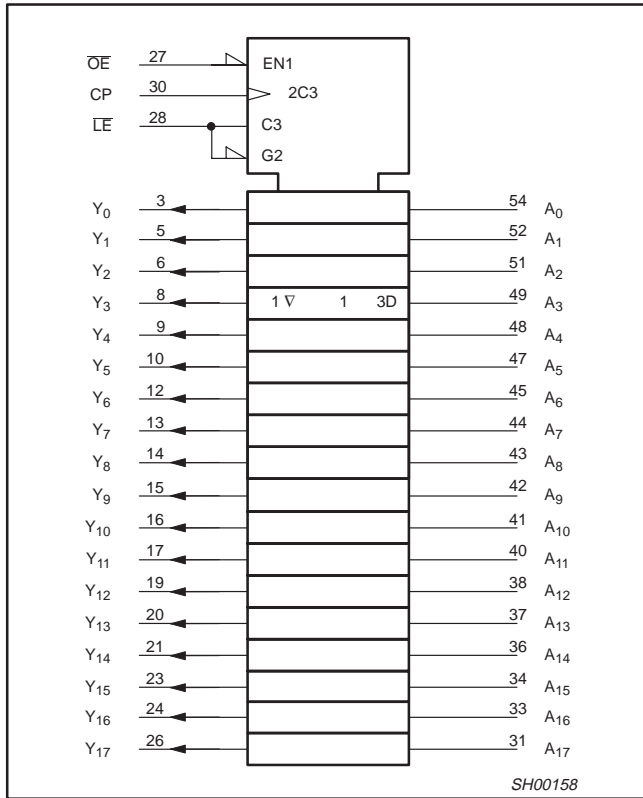

FUNCTION TABLE

INPUTS				OUTPUTS
OE	LE	CP	A	
H	X	X	X	Z
L	L	X	L	L
L	L	X	H	H
L	H	↑	L	L
L	H	↑	H	H
L	H	H	X	Y ₀ ¹
L	H	L	X	Y ₀ ²

H = HIGH voltage level
 L = LOW voltage level
 X = Don't care
 Z = High impedance "off" state
 ↑ = LOW-to-HIGH level transition

NOTES:

- Output level before the indicated steady-state input conditions were established, provided that CP is high before LE goes low.
- Output level before the indicated steady-state input conditions were established.

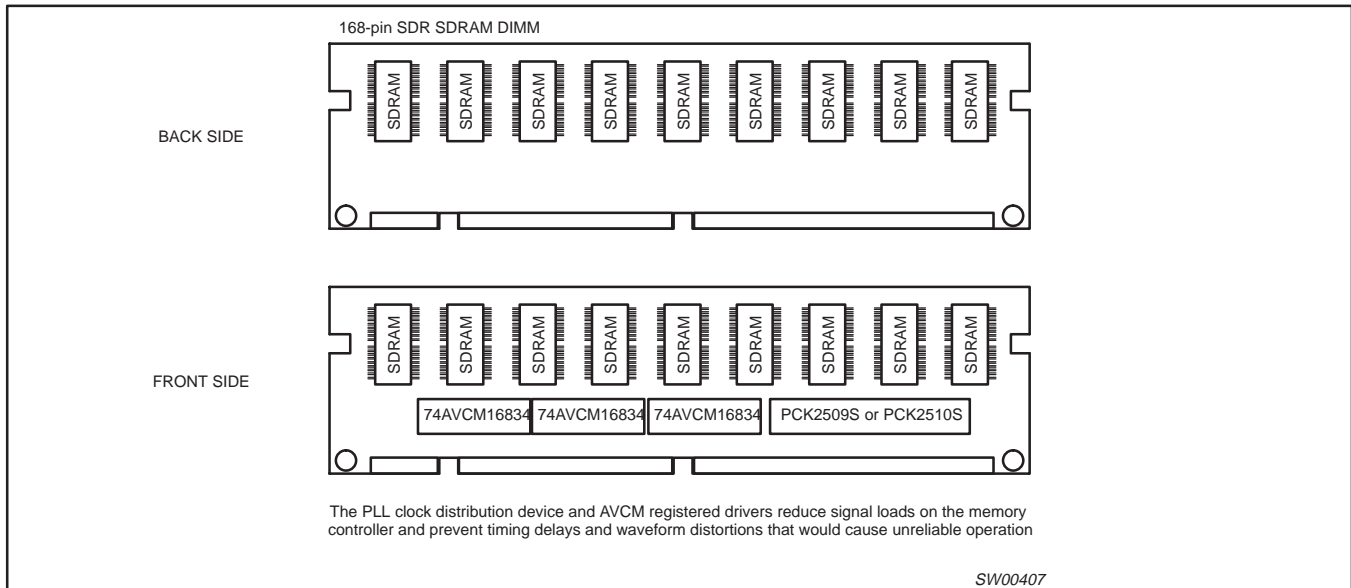

The PLL clock distribution device and AVCM registered drivers reduce signal loads on the memory controller and prevent timing delays and waveform distortions that would cause unreliable operation

18-bit registered driver with inverted register enable and Dynamic Controlled Outputs™ (3-State)

74AVC16834A

RECOMMENDED OPERATING CONDITIONS

SYMBOL	PARAMETER	CONDITIONS	MIN	MAX	UNIT
V_{CC}	DC supply voltage (according to JEDEC Low Voltage Standards)		1.65 2.3 3.0	1.95 2.7 3.6	V
	DC supply voltage (for low voltage applications)		1.2	3.6	V
V_I	DC Input voltage range		0	3.6	V
V_O	DC output voltage range; output 3-State		0	3.6	V
	DC output voltage range; output HIGH or LOW state		0	V_{CC}	
T_{amb}	Operating free-air temperature range		-40	+85	°C
t_p, t_f	Input rise and fall times	$V_{CC} = 1.65$ to 2.3 V	0	30	ns/V
		$V_{CC} = 2.3$ to 3.0 V	0	20	
		$V_{CC} = 3.0$ to 3.6 V	0	10	

ABSOLUTE MAXIMUM RATINGS

In accordance with the Absolute Maximum Rating System (IEC 134). Voltages are referenced to GND (ground = 0 V).

SYMBOL	PARAMETER	CONDITIONS	RATING	UNIT
V_{CC}	DC supply voltage		-0.5 to +4.6	V
I_{IK}	DC input diode current	$V_I < 0$	-50	mA
V_I	DC input voltage	For all inputs ¹	-0.5 to 4.6	V
I_{OK}	DC output diode current	$V_O > V_{CC}$ or $V_O < 0$	±50	mA
V_O	DC output voltage; output 3-State	Note 1	-0.5 to 4.6	V
V_O	DC output voltage; output HIGH or LOW state	Note 1	-0.5 to $V_{CC} + 0.5$	V
I_O	DC output source or sink current	$V_O = 0$ to V_{CC}	±50	mA
I_{GND}, I_{CC}	DC V_{CC} or GND current		±100	mA
T_{stg}	Storage temperature range		-65 to +150	°C
P_{TOT}	Power dissipation per package -plastic thin-medium-shrink (TSSOP)	For temperature range: -40 to +125 °C above +55 °C derate linearly with 8 mW/K	600	mW

NOTE:

1. The input and output voltage ratings may be exceeded if the input and output current ratings are observed.

18-bit registered driver with inverted register enable and Dynamic Controlled Outputs™ (3-State)

74AVC16834A

DC ELECTRICAL CHARACTERISTICS

Over recommended operating conditions. Voltage are referenced to GND (ground = 0 V).

SYMBOL	PARAMETER	TEST CONDITIONS	LIMITS			UNIT
			Temp = -40°C to +85°C			
			MIN	TYP ¹	MAX	
V _{IH}	HIGH level Input voltage	V _{CC} = 1.2 V	V _{CC}	-	-	V
		V _{CC} = 1.65 to 1.95 V	0.65V _{CC}	0.9	-	
		V _{CC} = 2.3 to 2.7 V	1.7	1.2	-	
		V _{CC} = 3.0 to 3.6 V	2.0	1.5	-	
V _{IL}	LOW level Input voltage	V _{CC} = 1.2 V	-	-	GND	V
		V _{CC} = 1.65 to 1.95 V	-	0.9	0.35V _{CC}	
		V _{CC} = 2.3 to 2.7 V	-	1.2	0.7	
		V _{CC} = 3.0 to 3.6 V	-	1.5	0.8	
V _{OH}	HIGH level output voltage	V _{CC} = 1.65 to 3.6V; V _I = V _{IH} or V _{IL} ; I _O = -100 μA	V _{CC} - 0.20	V _{CC}	-	V
		V _{CC} = 1.65 V; V _I = V _{IH} or V _{IL} ; I _O = -4 mA	V _{CC} - 0.45	V _{CC} - 0.10	-	
		V _{CC} = 2.3 V; V _I = V _{IH} or V _{IL} ; I _O = -8 mA	V _{CC} - 0.55	V _{CC} - 0.28	-	
		V _{CC} = 3.0 V; V _I = V _{IH} or V _{IL} ; I _O = -12 mA	V _{CC} - 0.70	V _{CC} - 0.32	-	
V _{OL}	LOW level output voltage	V _{CC} = 1.65 to 3.6 V; V _I = V _{IH} or V _{IL} ; I _O = 100 μA	-	GND	0.20	V
		V _{CC} = 1.65 V; V _I = V _{IH} or V _{IL} ; I _O = 4 mA	-	0.10	0.45	
		V _{CC} = 2.3 V; V _I = V _{IH} or V _{IL} ; I _O = 8 mA	-	0.26	0.55	
		V _{CC} = 3.0 V; V _I = V _{IH} or V _{IL} ; I _O = 12 mA	-	0.36	0.70	
I _I	Input leakage current	V _{CC} = 1.65 to 3.6 V; V _I = V _{CC} or GND	-	0.1	2.5	μA
I _{OFF}	3-State output OFF-state current	V _{CC} = 0 V; V _I or V _O = 3.6 V	-	0.1	± 10	μA
I _{IHZ/IILZ}	3-State output OFF-state current	V _{CC} = 1.65 to 3.6 V; V _I = V _{CC} or GND	-	0.1	12.5	μA
I _{OZ}	3-State output OFF-state current	V _{CC} = 1.65 to 2.7 V; V _I = V _{IH} or V _{IL} ; V _O = V _{CC} or GND	-	0.1	5	μA
		V _{CC} = 3.0 to 3.6 V; V _I = V _{IH} or V _{IL} ; V _O = V _{CC} or GND	-	0.1	10	
I _{CC}	Quiescent supply current	V _{CC} = 1.65 to 2.7 V; V _I = V _{CC} or GND; I _O = 0	-	0.1	20	μA
		V _{CC} = 3.0 to 3.6 V; V _I = V _{CC} or GND; I _O = 0	-	0.2	40	

NOTE:

1. All typical values are at T_{amb} = 25 °C.

18-bit registered driver with inverted register enable and Dynamic Controlled Outputs™ (3-State)

74AVC16834A

AC CHARACTERISTICS

GND = 0 V; $t_r = t_f \leq 2.0$ ns; $C_L = 30$ pF

SYMBOL	PARAMETER	WAVEFORM	LIMITS												UNIT	
			$V_{CC} = 3.3 \pm 0.3$ V			$V_{CC} = 2.5 \pm 0.2$ V			$V_{CC} = 1.8 \pm 0.15$ V			$V_{CC} = 1.5 \pm 0.1$ V		$V_{CC} = 1.5$ V		$V_{CC} = 1.2$ V
			MIN	TYP ¹	MAX	MIN	TYP ¹	MAX	MIN	TYP ¹	MAX	MIN	MAX	TYP		TYP
t_{PHL}/t_{PLH}	Propagation delay An to Yn	1, 7	0.9 0.7	1.7	2.6 2.5	1.0 0.8	2.0	3.2 3.0	1.5 1.0	2.8 2.6	4.9 4.5	2.0	5.8	3.6	5.9 5.2	ns
	Propagation delay \overline{LE} to Yn	2, 7	1.2 0.7	2.0 1.9	3.0 2.9	1.5 0.8	2.4 2.3	3.7 3.5	1.8 1.0	3.4 2.9	5.3	2.3	6.5	4.0	6.5 5.8	
	Propagation delay CP to Yn	3, 7	0.8 0.7	1.7	2.5	1.1 0.8	2.0	3.0	1.6 1.0	2.8 2.6	4.4 4.5	2.0	5.1	3.7	4.9 5.2	
t_{PZH}/t_{PZL}	3-State output enable time OE to Yn	6, 7	1.3 1.0	2.5 2.3	4.3 4.0	1.6 1.0	2.8 2.5	4.8 4.5	2.2 1.5	4.0 3.0	6.7 6.5	2.8	8.2	5.0	8.0 5.5	ns
t_{PHZ}/t_{PLZ}	3-State output disable time OE to Yn	6, 7	1.5 1.0	3.0 2.3	4.7 3.5	1.5 1.0	3.4 2.2	5.6 4.0	2.4 1.5	4.6 3.5	7.2 6.5	2.1	6.9	4.5	6.5 5.5	ns
t_w	CP pulse width HIGH or LOW	3, 7	1.0	–	–	1.2	–	–	2.0	–	–	–	–	–	–	ns
	\overline{LE} pulse width HIGH	2, 7	1.0	–	–	1.2	–	–	2.0	–	–	–	–	–	–	
t_{SU}	Set-up time An to CP	5, 7	0.3	–0.5	–	0.1	–0.2	–	0	–0.2	–	0.2	–	0	0	ns
	Set-up time An to \overline{LE}	4, 7	0.5	0.1	–	0.6	0.1	–	1.0	0.5	–	1.5	–	0.8	1.5	
t_h	Hold time An to CP	5, 7	0.9	0.6	–	0.7	0.3	–	0.7	0.3	–	0.6	–	0.3	0.1	ns
	Hold time An to \overline{LE}	4, 7	0.6	0.4	–	0.2	0.1	–	0.1	0	–	0.1	–	0	–0.7	
f_{max}	Maximum clock pulse frequency	3, 7	500	–	–	400	–	–	250	–	–	–	–	–	–	MHz

NOTE:

1. All typical values are measured at $T_{amb} = 25$ °C and at $V_{CC} = 1.8$ V, 2.5 V, 3.3 V.

18-bit registered driver with inverted register enable and Dynamic Controlled Outputs™ (3-State)

74AVC16834A

AC WAVEFORMS FOR $V_{CC} = 3.0\text{ V TO } 3.6\text{ V RANGE}$

$V_M = 0.5 V_{CC}$
 $V_X = V_{OL} + 0.300\text{ V}$
 $V_Y = V_{OH} - 0.300\text{ V}$
 V_{OL} and V_{OH} are the typical output voltage drop that occur with the output load.
 $V_I = V_{CC}$

AC WAVEFORMS FOR $V_{CC} = 2.3\text{ V TO } 2.7\text{ V AND } V_{CC} < 2.3\text{ V RANGE}$

$V_M = 0.5 V_{CC}$
 $V_X = V_{OL} + 0.15\text{ V}$
 $V_Y = V_{OH} - 0.15\text{ V}$
 V_{OL} and V_{OH} are the typical output voltage drop that occur with the output load.
 $V_I = V_{CC}$

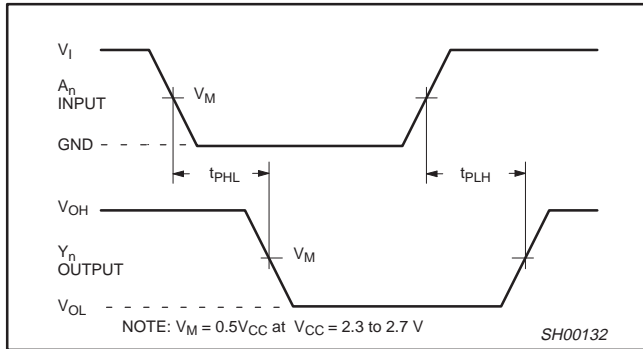

Waveform 1. Input (An) to output (Yn) propagation delay

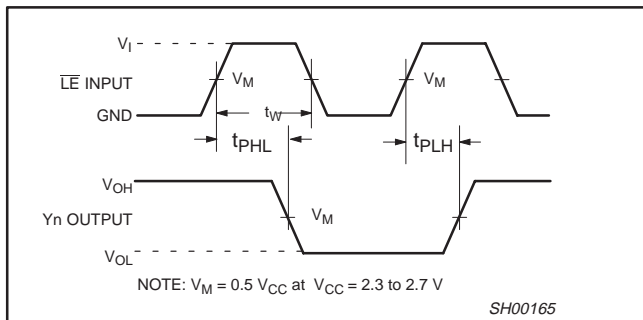

Waveform 2. Latch enable input (LE) pulse width, the latch enable input to output (Yn) propagation delays.

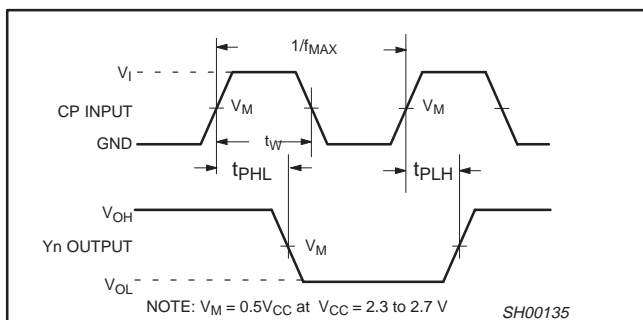

Waveform 3. The clock (CP) to Yn propagation delays, the clock pulse width and the maximum clock frequency.

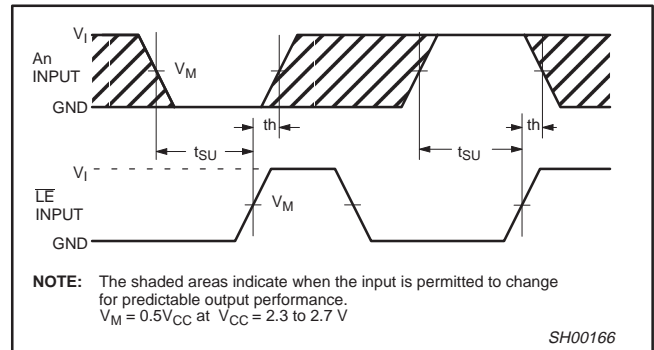

Waveform 4. Data set-up and hold times for the An input to the LE input

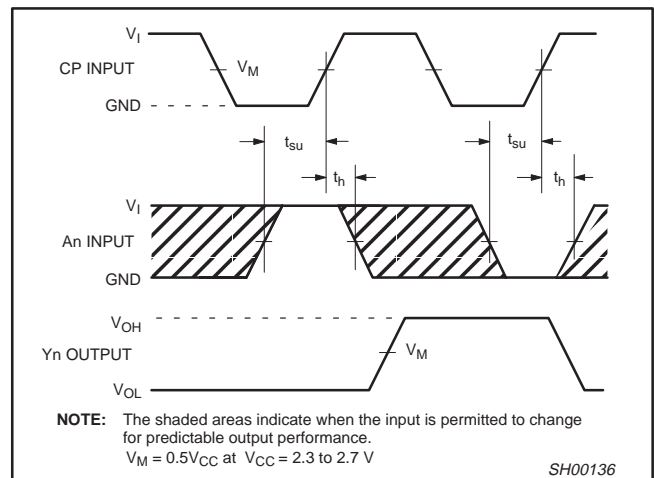

Waveform 5. Data set-up and hold times for the An input to the clock CP input

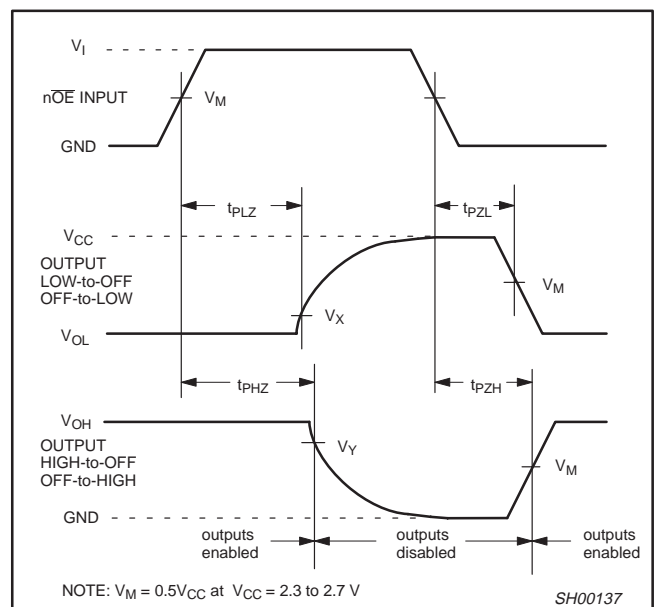

Waveform 6. 3-State enable and disable times

18-bit registered driver with inverted register enable and Dynamic Controlled Outputs™ (3-State)

74AVC16834A

TEST CIRCUIT

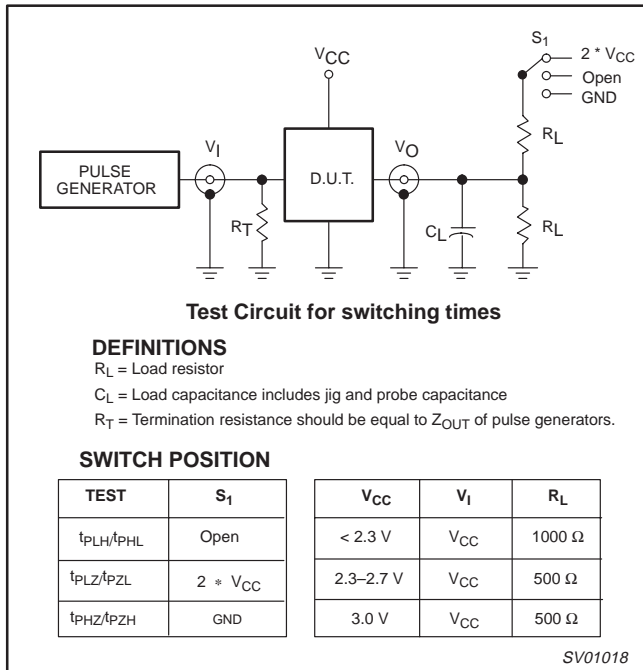

Waveform 7. Load circuitry for switching times

GRAPHS

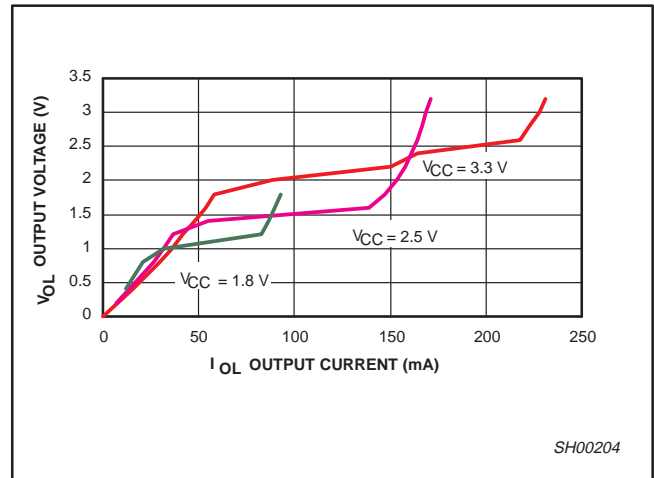

Figure 1. Output voltage (V_{OL}) vs. output current (I_{OL})

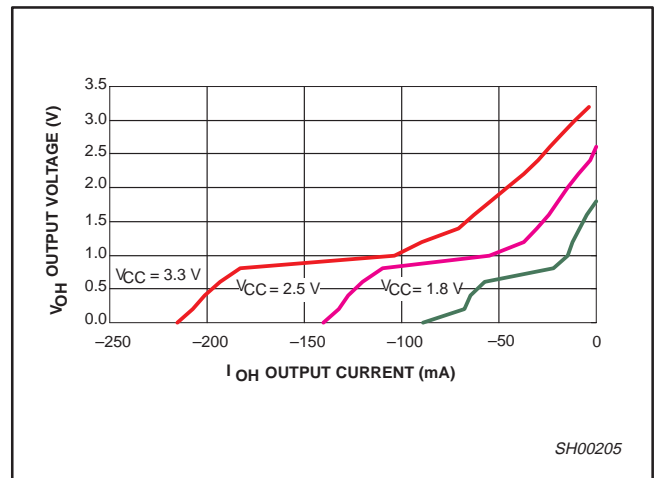

Figure 2. Output voltage (V_{OH}) vs. output current (I_{OH})

A Dynamic Controlled Output (DCO) circuit is designed in. During the transition, it initially lowers the output impedance to effectively drive the load and, subsequently, raises the impedance to reduce noise. Figures 1 and 2 show V_{OL} vs. I_{OL} and V_{OH} vs. I_{OH} curves to illustrate the output impedance and drive capability of the circuit. At the beginning of the signal transition, the DCO circuit provides a maximum dynamic drive that is equivalent to a high drive standard output device.

18-bit registered driver with inverted register enable
and Dynamic Controlled Outputs™ (3-State)

74AVC16834A

TSSOP56: plastic thin shrink small outline package; 56 leads; body width 6.1 mm

SOT364-1

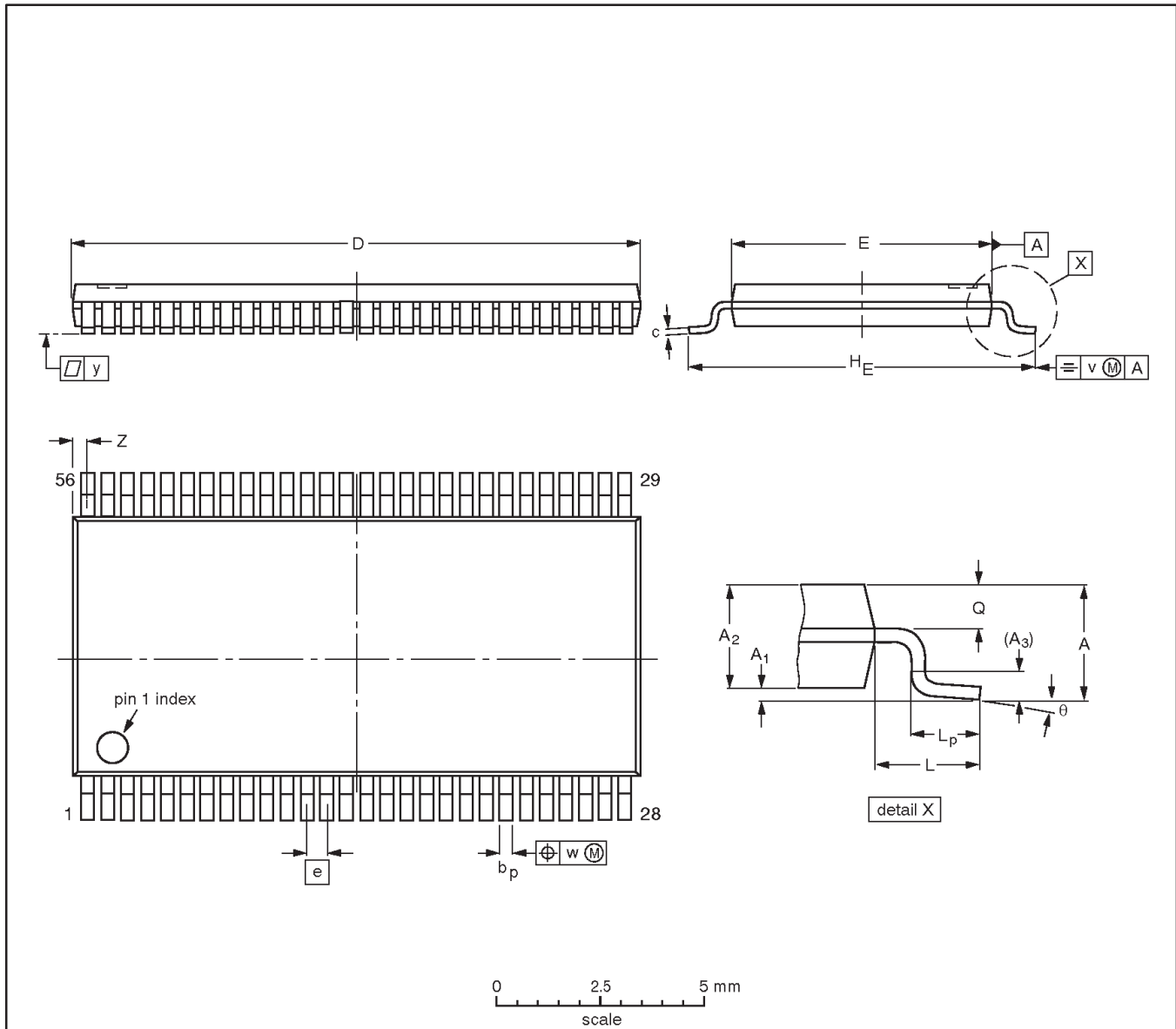

DIMENSIONS (mm are the original dimensions).

UNIT	A max.	A ₁	A ₂	A ₃	b _p	c	D ⁽¹⁾	E ⁽²⁾	e	H _E	L	L _p	Q	v	w	y	Z	θ
mm	1.2	0.15 0.05	1.05 0.85	0.25	0.28 0.17	0.2 0.1	14.1 13.9	6.2 6.0	0.5	8.3 7.9	1.0	0.8 0.4	0.50 0.35	0.25	0.08	0.1	0.5 0.1	8° 0°

Notes

1. Plastic or metal protrusions of 0.15 mm maximum per side are not included.
2. Plastic interlead protrusions of 0.25 mm maximum per side are not included.

OUTLINE VERSION	REFERENCES				EUROPEAN PROJECTION	ISSUE DATE
	IEC	JEDEC	EIAJ			
SOT364-1		MO-153				95-02-10 99-12-27

18-bit registered driver with inverted register enable and Dynamic Controlled Outputs™ (3-State)

74AVC16834A

TSSOP56: plastic thin shrink small outline package; 56 leads; body width 4.4 mm

SOT481-2

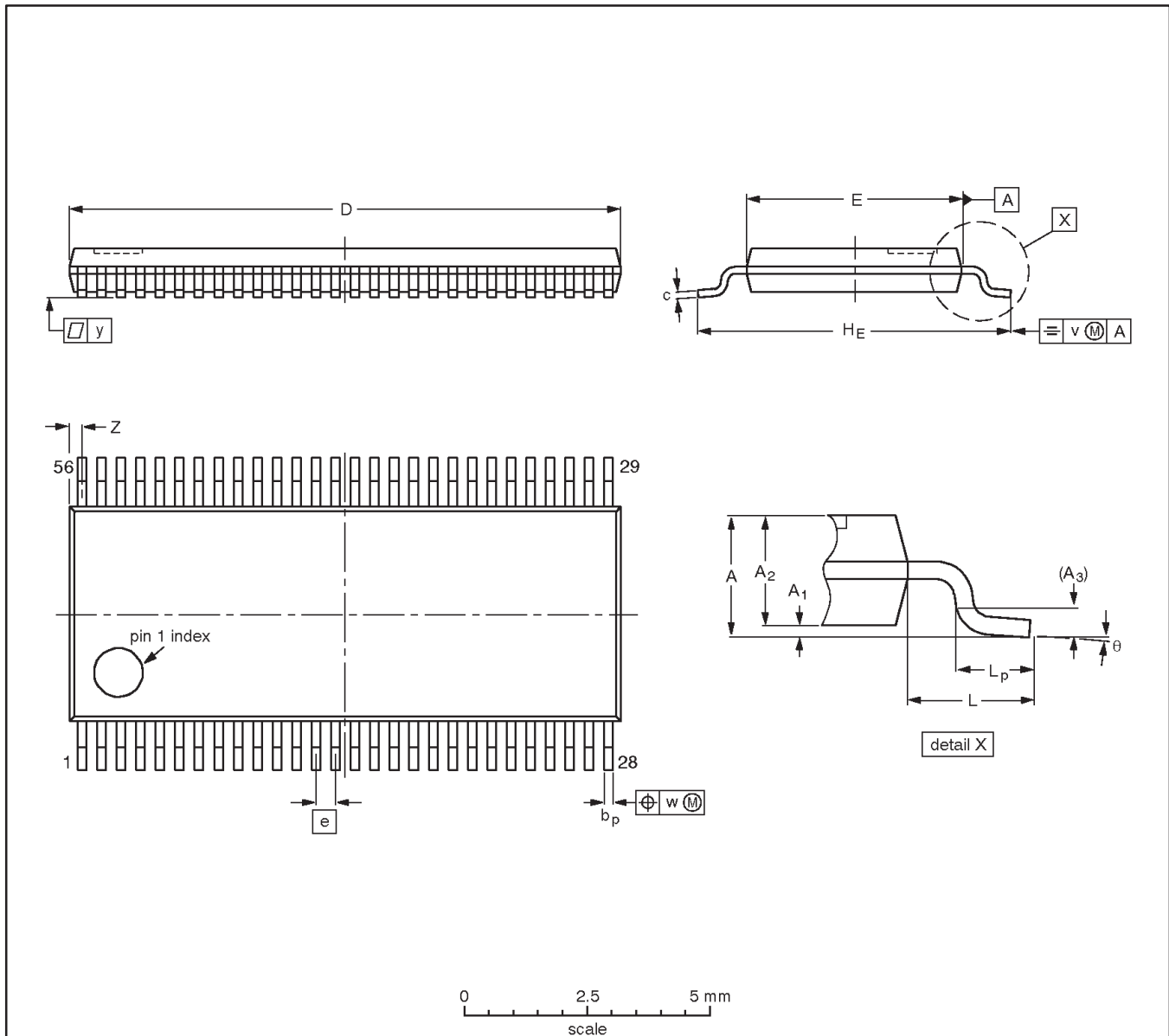

DIMENSIONS (mm are the original dimensions)

UNIT	A max.	A ₁	A ₂	A ₃	b _p	c	D (1)	E (2)	e	H _E	L	L _p	v	w	y	Z (1)	θ
mm	1.2	0.15 0.05	1.05 0.80	0.25	0.23 0.13	0.20 0.09	11.4 11.2	4.5 4.3	0.4	6.6 6.2	1	0.75 0.45	0.2	0.07	0.08	0.4 0.1	8° 0°

Notes

1. Plastic or metal protrusions of 0.15 mm maximum per side are not included.
2. Plastic or metal protrusions of 0.25 mm maximum per side are not included.

OUTLINE VERSION	REFERENCES				EUROPEAN PROJECTION	ISSUE DATE
	IEC	JEDEC	JEITA			
SOT481-2	---	MO-194	---			01-11-24

**18-bit registered driver with inverted register enable
and Dynamic Controlled Outputs™ (3-State)**

74AVC16834A

REVISION HISTORY

Rev	Date	Description
_4	2000 Jul 25	Product specification (9397 750 07353); fourth version. Engineering Change Notice: 853-2207 24201:
_5	2002 Sep 11	Product data (9397 750 10331); fifth version supersedes Product specification 2000 Jul 25. Engineering Change Notice: 853-2207 28874 (2002 Sep 09). Modifications: Add new package option (TVSOP) to existing product data sheet.

18-bit registered driver with inverted register enable and Dynamic Controlled Outputs™ (3-State)

74AVC16834A

Data sheet status

Data sheet status ^[1]	Product status ^[2]	Definitions
Objective data	Development	This data sheet contains data from the objective specification for product development. Philips Semiconductors reserves the right to change the specification in any manner without notice.
Preliminary data	Qualification	This data sheet contains data from the preliminary specification. Supplementary data will be published at a later date. Philips Semiconductors reserves the right to change the specification without notice, in order to improve the design and supply the best possible product.
Product data	Production	This data sheet contains data from the product specification. Philips Semiconductors reserves the right to make changes at any time in order to improve the design, manufacturing and supply. Changes will be communicated according to the Customer Product/Process Change Notification (CPCN) procedure SNW-SQ-650A.

[1] Please consult the most recently issued data sheet before initiating or completing a design.

[2] The product status of the device(s) described in this data sheet may have changed since this data sheet was published. The latest information is available on the Internet at URL <http://www.semiconductors.philips.com>.

Definitions

Short-form specification — The data in a short-form specification is extracted from a full data sheet with the same type number and title. For detailed information see the relevant data sheet or data handbook.

Limiting values definition — Limiting values given are in accordance with the Absolute Maximum Rating System (IEC 60134). Stress above one or more of the limiting values may cause permanent damage to the device. These are stress ratings only and operation of the device at these or at any other conditions above those given in the Characteristics sections of the specification is not implied. Exposure to limiting values for extended periods may affect device reliability.

Application information — Applications that are described herein for any of these products are for illustrative purposes only. Philips Semiconductors make no representation or warranty that such applications will be suitable for the specified use without further testing or modification.

Disclaimers

Life support — These products are not designed for use in life support appliances, devices or systems where malfunction of these products can reasonably be expected to result in personal injury. Philips Semiconductors customers using or selling these products for use in such applications do so at their own risk and agree to fully indemnify Philips Semiconductors for any damages resulting from such application.

Right to make changes — Philips Semiconductors reserves the right to make changes, without notice, in the products, including circuits, standard cells, and/or software, described or contained herein in order to improve design and/or performance. Philips Semiconductors assumes no responsibility or liability for the use of any of these products, conveys no license or title under any patent, copyright, or mask work right to these products, and makes no representations or warranties that these products are free from patent, copyright, or mask work right infringement, unless otherwise specified.

Contact information

For additional information please visit
<http://www.semiconductors.philips.com>. Fax: +31 40 27 24825

© Koninklijke Philips Electronics N.V. 2002
All rights reserved. Printed in U.S.A.

Date of release: 09-02

For sales offices addresses send e-mail to:
sales.addresses@www.semiconductors.philips.com

Document order number:

9397 750 10331

Let's make things better.

Looking for pricing, stock, or lifecycle information?

Click below to explore more details on WIN SOURCE:

- ⊖ [View 74AVC16834ADGV,118 on WIN SOURCE](#)
- ⊖ [NXP / Nexperia Information](#)

Optimize Your Supply Chain with WIN SOURCE Solutions

- ✓ Global Sourcing Solution
- ✓ Obsolete Management
- ✓ Cost Control Management
- ✓ Shortage Management
- ✓ Alternative Solution
- ✓ Excess Inventory Management