



**THE DATASHEET OF
SI4831-B30-GUR**



BROADCAST MECHANICAL TUNING AM/FM/SW RADIO RECEIVER

Features

- Worldwide FM band support (64–109 MHz)
- Worldwide AM band support (504–1750 kHz)
- SW band support (Si4835 only) (5.6–22 MHz)
- Excellent real-world performance
- EN55020-compliant
- No manual alignment necessary
- Flexible band selections
- Automatic frequency control (AFC)
- Integrated LDO regulator
- 2.0 to 3.6 V supply voltage
- Wide range of ferrite loop sticks and air loop antennas supported
- 24-pin SSOP
- RoHS-compliant
- Supports station and stereo LED indicators
- Direct volume control
- Bass and treble tone control

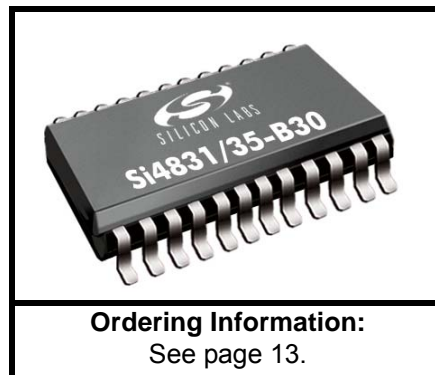

Applications

- Table and portable radios
- Stereos
- Mini/micro systems
- CD/DVD players
- Boom boxes
- Modules
- Clock radios
- Mini HiFi
- Entertainment systems

Description

The Si4831/35-B30 is the 2nd generation mechanical-tuned digital CMOS AM/FM/SW radio receiver IC that integrates the complete receiver function from antenna input to audio output. Like other successful audio products from Silicon Labs, Si4831/35-B30 offers unmatched integration and PCB space savings with minimum external components and a small board area. The Si4831/35-B30 requires a simple application circuit and removes any requirements for manually tuning components during the manufacturing process. The Si4831/35-B30 is a very simple product to design, manufacture, and support across multiple product lines. The receiver has very low power consumption, runs off two AAA batteries, and delivers the performance benefits of digital tuning to the analog radio market.

Functional Block Diagram

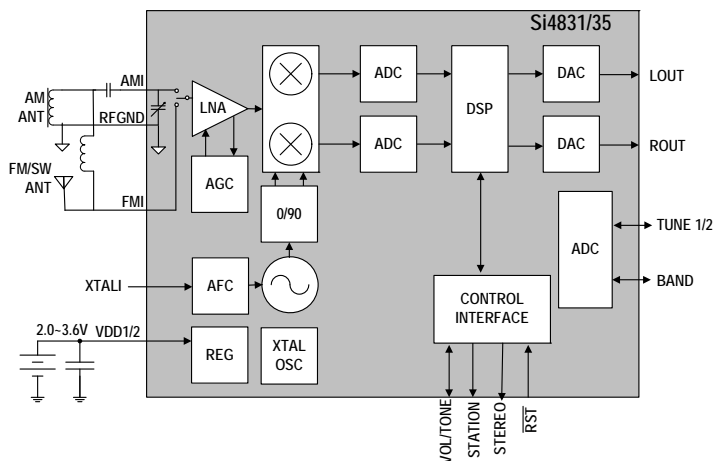

Pin Assignments

Si4831/35-B30 (SSOP)

STEREO	1	24	LOUT
STATION	2	23	ROUT
TUNE1	3	22	DBYP
TUNE2	4	21	VDD2
BAND	5	20	VDD1
NC	6	19	XTALI
NC	7	18	XTALO
FMI	8	17	VOL-/BASS
RFGND	9	16	VOL+/TREBLE
NC	10	15	RST
NC	11	14	GND
AMI	12	13	GND

This product, its features, and/or its architecture is covered by one or more of the following patents, as well as other patents, pending and issued, both foreign and domestic: 7,127,217; 7,272,373; 7,272,375; 7,321,324; 7,355,476; 7,426,376; 7,471,940; 7,339,503; 7,339,504.

TABLE OF CONTENTS

<u>Section</u>	<u>Page</u>
1. Electrical Specifications	4
2. Typical Application Schematic	8
3. Bill of Materials	9
4. Functional Description	10
4.1. Overview	10
4.2. FM Receiver	10
4.3. AM Receiver	11
4.4. SW Receiver	11
4.5. Frequency Tuning	11
4.6. Band Select	11
4.7. Bass and Treble	11
4.8. Volume Control	11
5. Pin Descriptions: Si4831/35-B30	12
6. Ordering Guide	13
7. Package Markings (Top Marks)	14
7.1. Si4831/35-B30 Top Mark	14
7.2. Top Mark Explanation	14
8. Package Outline: Si4831/35-B30	15
9. PCB Land Pattern: Si4831/35-B30	16
10. Additional Reference Resources	17
Document Change List	18
Contact Information	20

Si4831/35-B30

1. Electrical Specifications

Table 1. Recommended Operating Conditions^{1,2}

Parameter	Symbol	Test Condition	Min	Typ	Max	Unit
Supply Voltage ³	V _{DD}		2	—	3.6	V
Power Supply Powerup Rise Time	V _{DDRISE}		10	—	—	μs
Ambient Temperature	T _A		-15	25	85	°C

Note:

1. Typical values in the data sheet apply at V_{DD} = 3.3 V and 25 °C unless otherwise stated.
2. All minimum and maximum specifications in the data sheet apply across the recommended operating conditions for minimum V_{DD} = 2.7 V.
3. Operation at minimum V_{DD} is guaranteed by characterization when V_{DD} voltage is ramped down to 2.0 V. Part initialization may become unresponsive below 2.3 V.

Table 2. Absolute Maximum Ratings^{1,2}

Parameter	Symbol	Value	Unit
Supply Voltage	V _{DD}	-0.5 to 5.8	V
Input Current ³	I _{IN}	10	mA
Operating Temperature	T _{OP}	-40 to 95	°C
Storage Temperature	T _{STG}	-55 to 150	°C
RF Input Level ⁴		0.4	V _{PK}

Notes:

1. Permanent device damage may occur if the above Absolute Maximum Ratings are exceeded. Functional operation should be restricted to the conditions as specified in the operational sections of this data sheet. Exposure beyond recommended operating conditions for extended periods may affect device reliability.
2. The Si4831/35-B30 devices are high-performance RF integrated circuits with certain pins having an ESD rating of < 2 kV HBM. Handling and assembly of these devices should only be done at ESD-protected workstations.
3. For input pins RST, VOL+/TREBLE, VOL-/BASS, XTALO, XTALI, BAND, TUNE2, TUNE1, STATION, and STEREO.
4. At RF input pins, FMI and AMI.

Table 3. DC Characteristics $(V_{DD} = 2.7 \text{ to } 3.6 \text{ V}, T_A = -15 \text{ to } 85 \text{ }^\circ\text{C})$

Parameter	Symbol	Test Condition	Min	Typ	Max	Unit
FM Mode						
Supply Current ¹	I_{FM}		—	21.0	—	mA
Supply Current ²	I_{FM}	Low SNR level	—	21.5	—	mA
AM/SW Mode						
Supply Current ¹	I_{AM}		—	17.0	—	mA
Supplies and Interface						
V_{DD} Powerdown Current	I_{DDPD}		—	10	—	μA
Notes:						
1. Specifications are guaranteed by characterization.						
2. LNA is automatically switched to higher current mode for optimum sensitivity in weak signal conditions.						

Table 4. Reset Timing Characteristics $(V_{DD} = 2.7 \text{ to } 3.6 \text{ V}, T_A = -15 \text{ to } 85 \text{ }^\circ\text{C})$

Parameter	Symbol	Min	Typ	Max	Unit
$\overline{\text{RST}}$ Pulse Width and TUNE1, TUNE2 Setup to $\overline{\text{RST}}\uparrow$	t_{SRST}	100	—	—	μs
TUNE1, TUNE2 Hold from $\overline{\text{RST}}$	t_{HRST}	30	—	—	ns

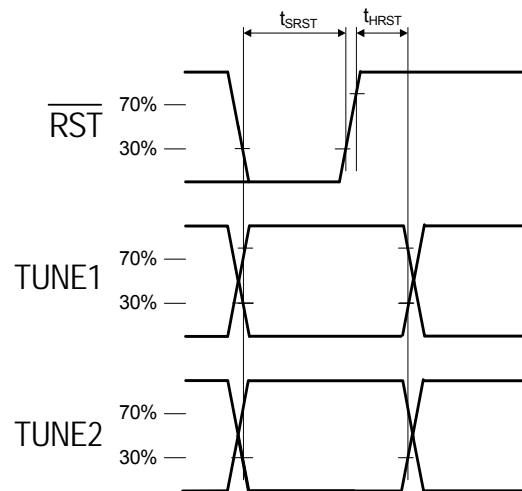
**Figure 1. Reset Timing**

Si4831/35-B30

Table 5. FM Receiver Characteristics^{1,2}

(V_{DD} = 2.7 to 3.6 V, T_A = -15 to 85 °C)

Parameter	Symbol	Test Condition	Min	Typ	Max	Unit
Input Frequency	f_{RF}		64	—	109	MHz
Sensitivity with Headphone Network ³		(S+N)/N = 26 dB	—	2.2	—	μ V EMF
LNA Input Resistance ^{4,5}			—	4	—	k Ω
LNA Input Capacitance ^{4,5}			—	5	—	pF
AM Suppression ^{4,5,6,7}		m = 0.3	—	50	—	dB
Input IP ₃ ^{4,8}			—	105	—	dB μ V EMF
Adjacent Channel Selectivity ⁴		\pm 200 kHz	—	50	—	dB
Alternate Channel Selectivity ⁴		\pm 400 kHz	—	65	—	dB
Audio Output Voltage ^{5,6,7}			—	80	—	mV _{RMS}
Audio Mono S/N ^{5,6,7,9,10}			—	55	—	dB
Audio Stereo S/N ^{3,4,5,7,9,10,}			—	55	—	dB
Audio Frequency Response Low		-3 dB	—	—	30	Hz
Audio Frequency Response High		-3 dB	15	—	—	kHz
Audio Stereo Separation ^{5,11}			—	42	—	dB
Audio THD ^{6,5,11}			—	0.1	0.5	%
Audio Output Load Resistance ^{4,10}	R_L	Single-ended	10	—	—	k Ω
Audio Output Load Capacitance ^{4,10}	C_L	Single-ended	—	—	50	pF
Powerup/Band Switch Time ⁴			—	—	110	ms

Notes:

1. Additional testing information is available in “AN569: Si4831/35-DEMO Board Test Procedure.” Volume = maximum for all tests. Tested at R_F = 98.1 MHz.
2. To ensure proper operation and receiver performance, follow the guidelines in “AN555: Si483x-B Antenna, Schematic, Layout, and Design Guidelines.” Silicon Laboratories will evaluate schematics and layouts for qualified customers.
3. Frequency is 76~109 MHz.
4. Guaranteed by characterization.
5. V_{EMF} = 1 mV.
6. F_{MOD} = 1 kHz, MONO, and L = R unless noted otherwise.
7. Δf = 22.5 kHz.
8. $|f_2 - f_1| > 2$ MHz, $f_0 = 2 \times f_1 - f_2$.
9. B_{AF} = 300 Hz to 15 kHz, A-weighted.
10. At L_{OUT} and R_{OUT} pins.
11. Δf = 75 kHz.

Table 6. AM/SW Receiver Characteristics^{1, 2}(V_{DD} = 2.7 to 3.6 V, T_A = -15 to 85 °C)

Parameter	Symbol	Test Condition	Min	Typ	Max	Unit
Input Frequency	f _{RF}	Medium Wave (AM)	504	—	1750	kHz
		Short Wave (SW)	5.60	—	22.0	MHz
Sensitivity ^{3,4,5}		(S+N)/N = 26 dB	—	30	—	μV EMF
Large Signal Voltage Handling ⁵		THD < 8%	—	300	—	mV _{RMS}
Power Supply Rejection Ratio ⁵		ΔV _{DD} = 100 mV _{RMS} , 100 Hz	—	40	—	dB
Audio Output Voltage ^{3,6}			—	60	—	mV _{RMS}
Audio S/N ^{3,4,6}			—	55	—	dB
Audio THD ^{3,6}			—	0.1	0.5	%
Antenna Inductance ^{5,7}			180	—	450	μH
Powerup/Band Switch Time ⁵		From powerdown	—	—	110	ms

Notes:

1. Additional testing information is available in "AN569: Si4831/35-DEMO Board Test Procedure." Volume = maximum for all tests. Tested at RF = 520 kHz.
2. To ensure proper operation and receiver performance, follow the guidelines in "AN555: Si483x-B Antenna, Schematic, Layout, and Design Guidelines." Silicon Laboratories will evaluate schematics and layouts for qualified customers.
3. F_{MOD} = 1 kHz, 30% modulation, 2 kHz channel filter.
4. B_{AF} = 300 Hz to 15 kHz, A-weighted.
5. Guaranteed by characterization.
6. V_{IN} = 5 mV_{rms}.
7. Stray capacitance on antenna and board must be < 10 pF to achieve full tuning range at higher inductance levels.

Table 7. Reference Clock and Crystal Characteristics(V_{DD} = 2.7 to 3.6 V, T_A = -15 to 85 °C)

Parameter	Symbol	Test Condition	Min	Typ	Max	Unit
Reference Clock						
XTALI Supported Reference Clock Frequencies			—	32.768	—	kHz
Reference Clock Frequency Tolerance for XTALI			-100	—	100	ppm
Crystal Oscillator						
Crystal Oscillator Frequency			—	32.768	—	kHz
Crystal Frequency Tolerance			-100	—	100	ppm
Board Capacitance			—	—	3.5	pF

Si4831/35-B30

2. Typical Application Schematic

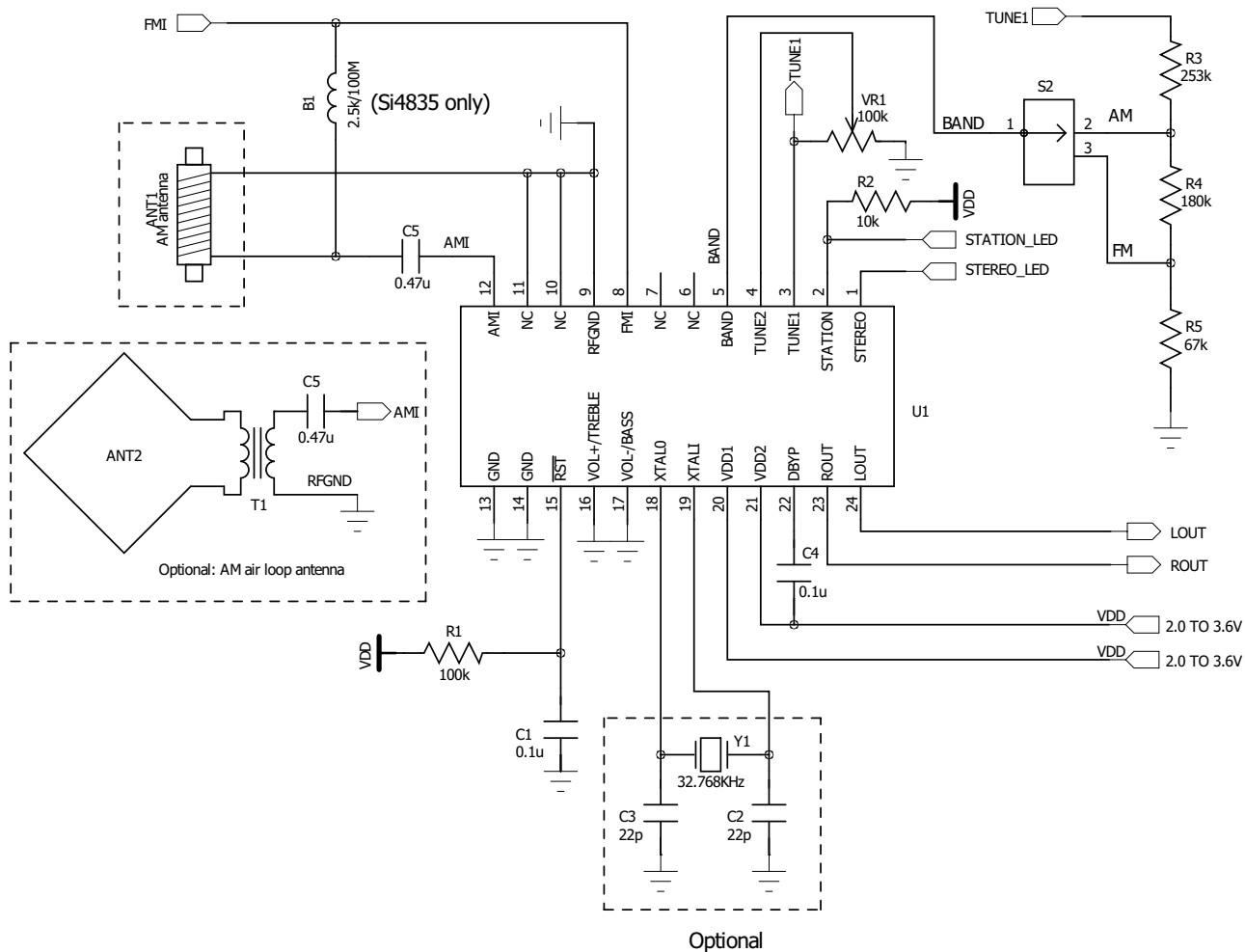

Notes:

1. Place C_4 close to V_{DD2} and DBYP pins.
2. All grounds connect directly to GND plane on PCB.
3. Pin 6 and 7 leave floating.
4. To ensure proper operation and receiver performance, follow the guidelines in "AN555: Si483x-B Antenna, Schematic, Layout, and Design Guidelines." Silicon Labs will evaluate the schematics and layouts for qualified customers.
5. Pin 8 connects to the FM antenna interface and pin 12 connects to the AM antenna interface.
6. Place Si483x as close as possible to antenna jack and keep the FMI and AMI traces as short as possible.

3. Bill of Materials

Table 8. Si4831/35-B30 Bill of Materials

Component(s)	Value/Description	Supplier
C1	Reset capacitor 0.1 uF, ±20%, Z5U/X7R	Murata
C4	Supply bypass capacitor, 0.1 uF, ±20%, Z5U/X7R	Murata
C5	Coupling capacitor, 0.47 µF, ±20%, Z5U/X7R	Murata
B1	Ferrite bead 2.5k/100 MHz	Murata
VR1	Variable resistor (POT), 100k, ±10%	Kennon
R1	Reset timing resistor, 100k, ±5%	Venkel
R2	Resistor, 10k, ±5%	Venkel
R3	Resistor, 253k, ±1%	Venkel
R4	Resistor, 180k, ±1%	Venkel
R5	Resistor, 67k, ±1%	Venkel
U1	Si4831/35-B30 Mechanical Tuning Radio Receiver	Silicon Laboratories
S2	Band switch	Any, depends on customer
ANT1	Ferrite stick, 180-450 µH	Jiaxin
Optional Components		
C2, C3	Crystal load capacitors, 22 pF, ±5%, COG (Optional: for crystal oscillator option)	Venkel
Y1	32.768 kHz crystal (Optional: for crystal oscillator option)	Epson or equivalent
ANT2	Air loop antenna, 10–20 µH	Various

4. Functional Description

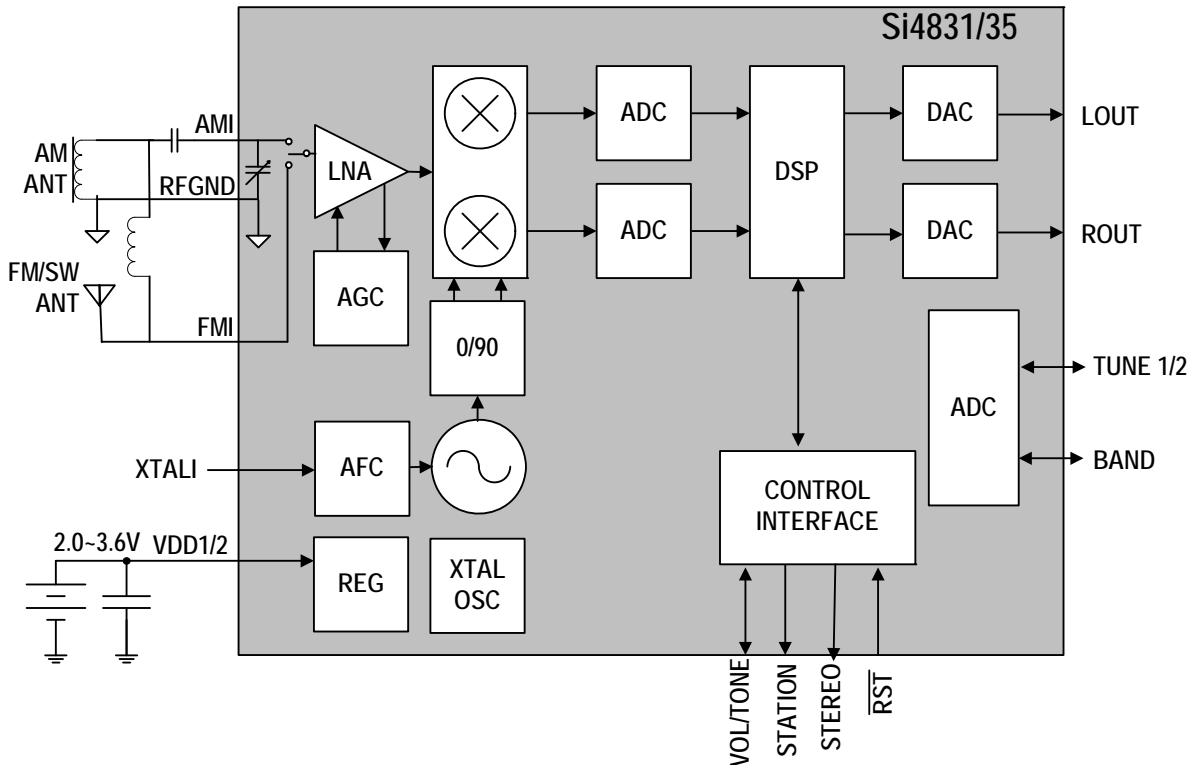

Figure 2. Si4831/35-B30 Functional Block Diagram

4.1. Overview

The Si4831/35-B30 is the industry's most advanced fully integrated, mechanical-tuned 100% CMOS AM/FM/SW radio receiver IC. Offering unmatched integration and PCB space savings, the Si4831/35-B30 requires minimum external components and a small board area. The Si4831/35-B30 AM/FM/SW radio provides space savings and low power consumption while delivering the high performance and design simplicity desired for all AM/FM/SW solutions.

Leveraging Silicon Laboratories' proven and patented digital low intermediate frequency (low-IF) receiver architecture, the Si4831/35-B30 delivers superior RF performance and interference rejection in AM, FM, and SW bands. The high integration and complete system production test simplifies design-in, increases system quality, and improves manufacturability.

4.2. FM Receiver

The Si4831/35-B30 integrates a low noise amplifier (LNA) supporting the worldwide FM broadcast band (64 to 109 MHz).

Pre-emphasis and de-emphasis is a technique used by FM broadcasters to improve the signal-to-noise ratio of FM receivers by reducing the effects of high frequency interference and noise. When the FM signal is transmitted, a pre-emphasis filter is applied to accentuate the high audio frequencies. All FM receivers incorporate a de-emphasis filter which attenuates high frequencies to restore a flat frequency response. Two time constants are used in various regions. The de-emphasis time constant can be chosen to be 50 or 75 μ s. Refer to "AN555: Si483x-B Antenna, Schematic, Layout, and Design Guidelines."

The Si4831/35-B30 also has advanced stereo blending that employs adaptive noise suppression. As a signal quality degrades, the Si4831/35-B30 gradually combines the stereo left and right audio channels to a mono audio signal to maintain optimum sound fidelity under varying reception conditions. The Si4831/35-B30 can drive a stereo light with the stereo/mono information so that the user can easily discern the signal quality.

The stereo light up criteria is defined using both RSSI and the Left and Right separation levels as these two specifications are the primary factors for stereo listening. The criteria can be set between two conditions: the Left and Right channels are separated by more than 6 dB with RSSI at >20 dB or Left and Right channels are separated by more than 12 dB with RSSI at >28 dB. The selection can be set up using different values of the external resistor. Refer to "AN555: Si483x-B Antenna, Schematic, Layout, and Design Guidelines."

4.3. AM Receiver

The highly integrated Si4831/35-B30 supports worldwide AM band reception from 504 to 1750 kHz with five sub-bands using a digital low-IF architecture with a minimum number of external components and no manual alignment required. This patented architecture allows for high-precision filtering, offering excellent selectivity and SNR with minimum variation across the AM band. Similar to the FM receiver, the Si4831/35-B30 optimizes sensitivity and rejection of strong interferers, allowing better reception of weak stations.

To offer maximum flexibility, the receiver supports a wide range of ferrite loop sticks from 180–450 μ H. An air loop antenna is supported by using a transformer to increase the effective inductance from the air loop. Using a 1:5 turn ratio inductor, the inductance is increased by 25 times and easily supports all typical AM air loop antennas, which generally vary between 10 and 20 μ H.

4.4. SW Receiver

The Si4835 supports 16 short wave (SW) band receptions from 5.60 to 22.0 MHz. Si4835 supports extensive short wave features such as minimal discrete components and no factory adjustments. The Si4835 supports using the FM antenna to capture short wave signals.

4.5. Frequency Tuning

A valid channel can be found by tuning the potentiometer that is connected to the TUNE1 and TUNE2 pin of the Si4831/35-B30 chip.

To offer easy tuning, the Si4831/35-B30 also supports a station LED light. It will light up the LED if the RF signal quality passes the LED sensitivity threshold when tuned to a valid station.

4.6. Band Select

The Si4831/35-B30 supports worldwide AM band with five sub-bands, US/Europe/Japan/China FM band with five sub-bands, and SW band with 16 sub-bands. For details on band selection, refer to "AN555: Si483x-B Antenna, Schematic, Layout, and Design Guidelines."

4.7. Bass and Treble

The Si4831/35-B30 further supports bass and treble tone control for superior sound quality. Pins 16 and 17 can be configured for tone control, allowing customers to use either two buttons or one slide-switch to adjust the bass and treble. For further configuration details, refer to "AN555: Si483x-B Antenna, Schematic, Layout, and Design Guidelines."

4.8. Volume Control

The Si4831/35-B30 not only allows customers to use the traditional PVR wheel volume control through an external speaker amplifier, it also supports direct digital volume control through pins 16 and pin 17 by using volume up and down buttons. Refer to "AN555: Si483x-B Antenna, Schematic, Layout, and Design Guidelines."

Si4831/35-B30

5. Pin Descriptions: Si4831/35-B30

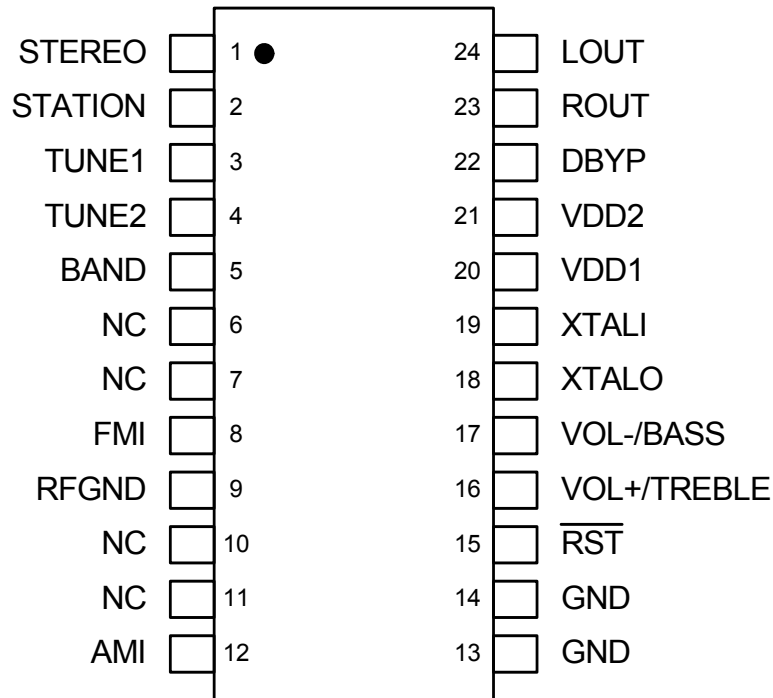

Pin Number(s)	Name	Description
1	STEREO	Stereo indicator
2	STATION	Station indicator
3	TUNE1	Frequency tuning
4	TUNE2	Frequency tuning
5	BAND	Band selection and De-emphasis/Stereo separation selection
6,7	NC	No connect. Leave floating.
8	FMI	FM RF inputs. FMI should be connected to the antenna trace.
9	RFGND	RF ground. Connect to ground plane on PCB.
10,11	NC	Unused. Tie these pins to GND.
12	AMI	AM RF input. AMI should be connected to the AM antenna.
13,14	GND	Ground. Connect to ground plane on PCB.
15	$\overline{\text{RST}}$	Device reset (active low) input
16	VOL+/TREBLE	Volume button up/Treble
17	VOL-/BASS	Volume button down/Bass
18	XTALO	Crystal oscillator output
19	XTALI	Crystal oscillator input
20	VDD1	Supply voltage. May be connected directly to battery.
21	VDD2	Supply voltage. May be connected directly to battery.
22	DBYP	Dedicated bypass for VDD
23	ROUT	Right audio line output in analog output mode
24	LOUT	Left audio line output in analog output mode

6. Ordering Guide

Part Number*	Description	Package Type	Operating Temperature/Voltage
Si4831-B30-GU	AM/FM Broadcast Radio Receiver	24L SSOP Pb-free	-15 to 85 °C 2.0 to 3.6 V
Si4835-B30-GU	AM/FM/SW Broadcast Radio Receiver	24L SSOP Pb-free	-15 to 85 °C 2.0 to 3.6 V

***Note:** Add an "(R)" at the end of the device part number to denote tape and reel option. The devices will typically operate at 25 °C with degraded specifications for V_{DD} voltage ramped down to 2.0 V.

Si4831/35-B30

7. Package Markings (Top Marks)

7.1. Si4831/35-B30 Top Mark

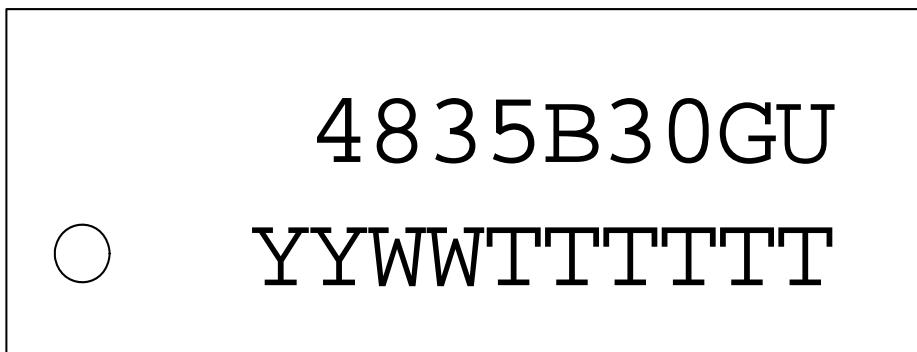
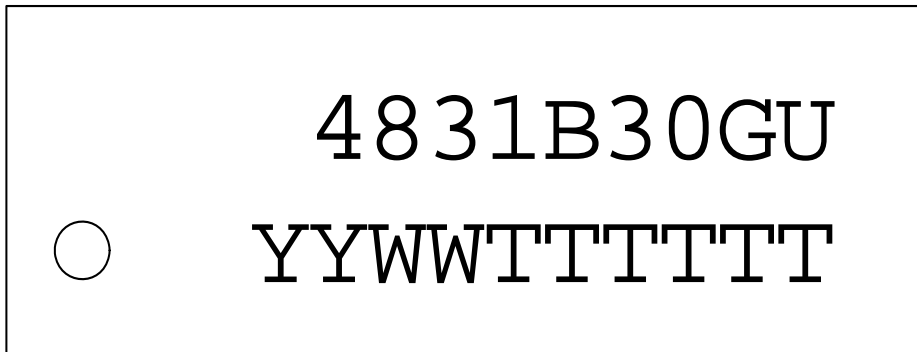

7.2. Top Mark Explanation

Mark Method:	YAG Laser	
Line 1 Marking:	Device identifier	4831B30GU = Si4831-B30 4835B30GU = Si4835-B30
Line 2 Marking:	YY = Year WW = Work week TTTTTT = Manufacturing code	Assigned by the Assembly House.

8. Package Outline: Si4831/35-B30

The 24-pin SSOP illustrates the package details for the Si4831/35-B30. Table 9 lists the values for the dimensions shown in the illustration.

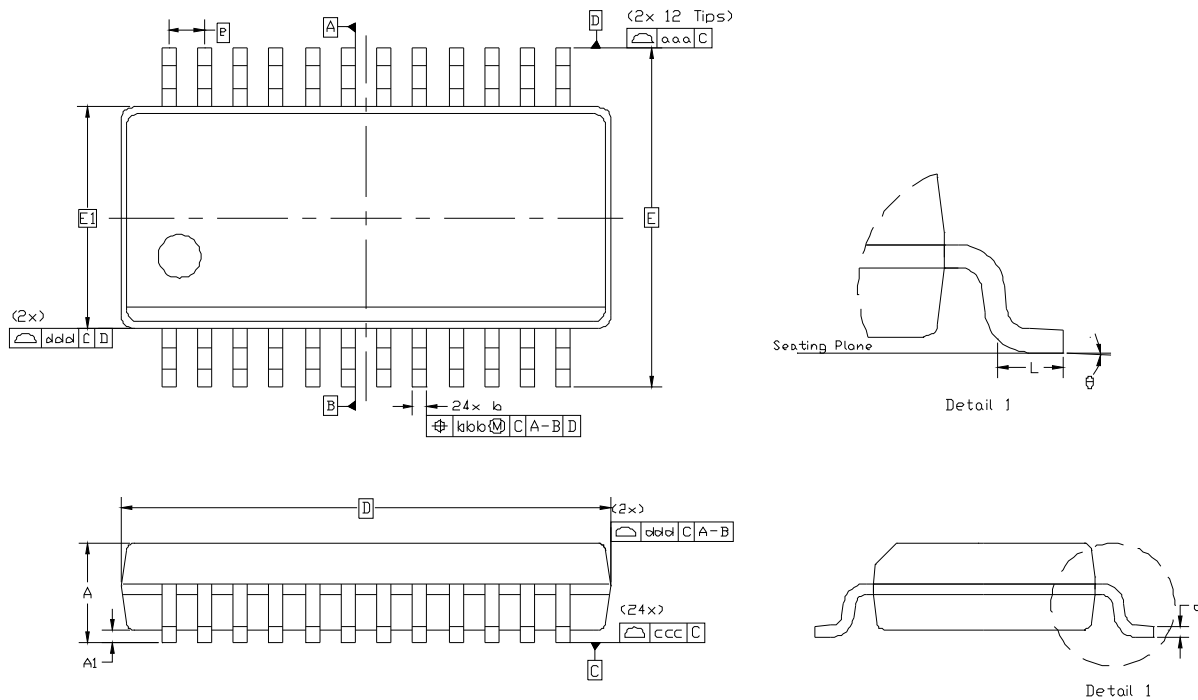

Figure 3. 24-Pin SSOP

Table 9. Package Dimensions

Dimension	Min	Nom	Max
A	—	—	1.75
A1	0.10	—	0.25
b	0.20	—	0.30
c	0.10	—	0.25
D	8.65 BSC		
E	6.00 BSC		
E1	3.90 BSC		
e	0.635 BSC		
L	0.40	—	1.27
θ	0°	—	8°
aaa	0.20		
bbb	0.18		
ccc	0.10		
ddd	0.10		
Notes:			
1. All dimensions shown are in millimeters (mm) unless otherwise noted.			
2. Dimensioning and Tolerancing per ANSI Y14.5M-1994.			
3. This drawing conforms to the JEDEC Solid State Outline MO-137, Variation AE.			
4. Recommended card reflow profile is per the JEDEC/IPC J-STD-020 specification for Small Body Components.			

9. PCB Land Pattern: Si4831/35-B30

Figure 4, “PCB Land Pattern,” illustrates the PCB land pattern details for the Si4831/35-B30-GU SSOP. Table 10 lists the values for the dimensions shown in the illustration.

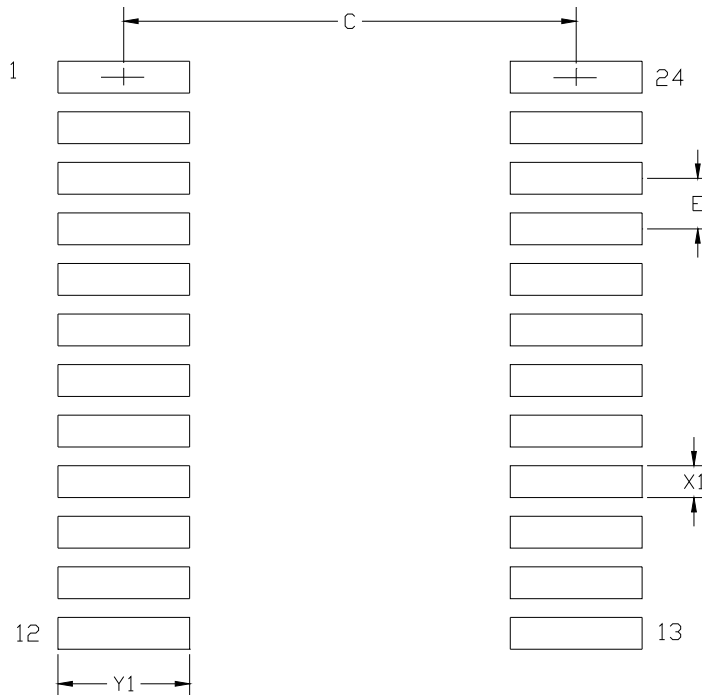

Figure 4. PCB Land Pattern

Table 10. PCB Land Pattern Dimensions

Dimension	Min	Max
C	5.20	5.40
E	0.65 BSC	
X1	0.35	0.45
Y1	1.55	1.75
General:		
1. All dimensions shown are in millimeters (mm) unless otherwise noted.		
2. This land pattern design is based on the IPC-7351 guidelines.		
Solder Mask Design:		
3. All metal pads are to be non-solder mask defined (NSMD). Clearance between the solder mask and the metal pad is to be 60 µm minimum, all the way around the pad.		
Stencil Design:		
4. A stainless steel, laser-cut, and electro-polished stencil with trapezoidal walls should be used to assure good solder paste release.		
5. The stencil thickness should be 0.125 mm (5 mils).		
6. The ratio of stencil aperture to land pad size should be 1:1 for all perimeter pads.		
Card Assembly:		
7. A No-Clean, Type-3 solder paste is recommended.		
8. The recommended card reflow profile is per the JEDEC/IPC J-STD-020 specification for Small Body Components.		

10. Additional Reference Resources

Contact your local sales representatives for more information or to obtain copies of the following references:

- EN55020 Compliance Test Certificate
- AN555: Si483x-B Antenna, Schematic, Layout, and Design Guidelines
- AN569: Si4831/35-DEMO Board Test Procedure
- Si4831/35-DEMO Board User's Guide

DOCUMENT CHANGE LIST

Revision 0.1 to Revision 0.7

- Updated block diagram.
- Updated application schematic.
- Updated bill of materials.
- Updated Section “4.2. FM Receiver”.
- Updated Section “4.3. AM Receiver”.
- Updated Section “4.6. Band Select”.

Revision 0.7 to Revision 1.0

- Updated block diagram
- Updated Table 2, “Absolute Maximum Ratings^{1,2},” on page 4
- Updated Table 5, “FM Receiver Characteristics^{1,2},” on page 6
- Updated Table 6, “AM/SW Receiver Characteristics^{1,2},” on page 7
- Updated “4. Functional Description”
- Updated “10. Additional Reference Resources”

NOTES:

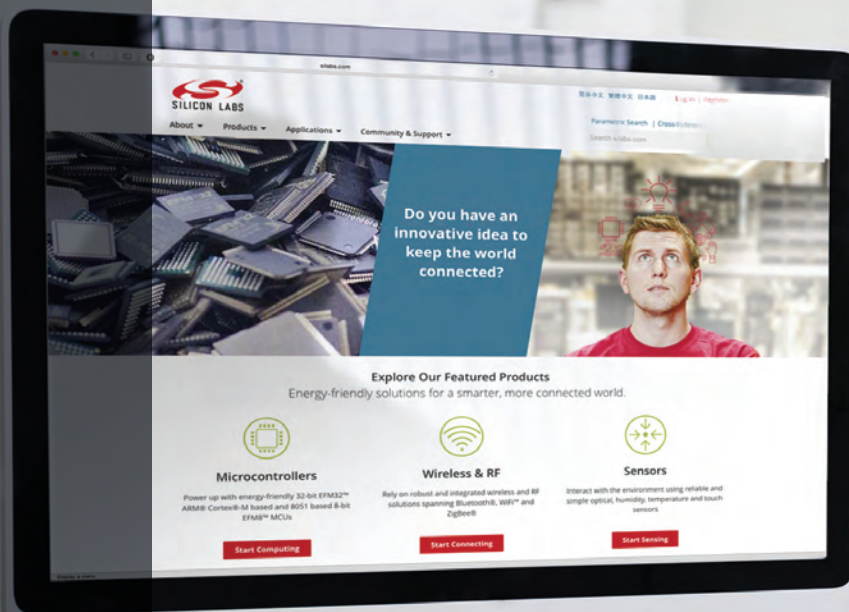

Smart.
Connected.
Energy-Friendly



Products
www.silabs.com/products

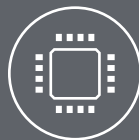

Quality
www.silabs.com/quality



Support and Community
community.silabs.com

Disclaimer

Silicon Laboratories intends to provide customers with the latest, accurate, and in-depth documentation of all peripherals and modules available for system and software implementers using or intending to use the Silicon Laboratories products. Characterization data, available modules and peripherals, memory sizes and memory addresses refer to each specific device, and "Typical" parameters provided can and do vary in different applications. Application examples described herein are for illustrative purposes only. Silicon Laboratories reserves the right to make changes without further notice and limitation to product information, specifications, and descriptions herein, and does not give warranties as to the accuracy or completeness of the included information. Silicon Laboratories shall have no liability for the consequences of use of the information supplied herein. This document does not imply or express copyright licenses granted hereunder to design or fabricate any integrated circuits. The products must not be used within any Life Support System without the specific written consent of Silicon Laboratories. A "Life Support System" is any product or system intended to support or sustain life and/or health, which, if it fails, can be reasonably expected to result in significant personal injury or death. Silicon Laboratories products are generally not intended for military applications. Silicon Laboratories products shall under no circumstances be used in weapons of mass destruction including (but not limited to) nuclear, biological or chemical weapons, or missiles capable of delivering such weapons.

Trademark Information

Silicon Laboratories Inc., Silicon Laboratories, Silicon Labs, SiLabs and the Silicon Labs logo, CMEMS®, EFM, EFM32, EFR, Energy Micro, Energy Micro logo and combinations thereof, "the world's most energy friendly microcontrollers", Ember®, EZLink®, EZMac®, EZRadio®, EZRadioPRO®, DSPLL®, ISOmodem®, Precision32®, ProSLIC®, SiPHY®, USBXpress® and others are trademarks or registered trademarks of Silicon Laboratories Inc. ARM, CORTEX, Cortex-M3 and THUMB are trademarks or registered trademarks of ARM Holdings. Keil is a registered trademark of ARM Limited. All other products or brand names mentioned herein are trademarks of their respective holders.



Silicon Laboratories Inc.
400 West Cesar Chavez
Austin, TX 78701
USA

<http://www.silabs.com>

Looking for pricing, stock, or lifecycle information?

Click below to explore more details on WIN SOURCE:

 [View SI4831-B30-GUR on WIN SOURCE](#)

 [Silicon Labs](#) Information

Optimize Your Supply Chain with WIN SOURCE Solutions

-  Global Sourcing Solution
-  Obsolete Management
-  Cost Control Management
-  Shortage Management
-  Alternative Solution
-  Excess Inventory Management