



**THE DATASHEET OF  
SI4730-D60-GMR**







---

**TABLE OF CONTENTS**

---

<b><u>Section</u></b>	<b><u>Page</u></b>
<b>1. Electrical Specifications</b>	<b>5</b>
<b>2. Typical Application Schematic</b>	<b>18</b>
2.1. QFN Typical Application Schematic	18
2.2. SSOP Typical Application Schematic	19
<b>3. Bill of Materials</b>	<b>20</b>
3.1. QFN/SSOP Bill of Materials	20
<b>4. Functional Description</b>	<b>21</b>
4.1. Overview	21
4.2. Operating Modes	22
4.3. FM Receiver	22
4.4. AM Receiver	22
4.5. SW Receiver	22
4.6. LW Receiver	22
4.7. Digital Audio Interface	23
4.8. Stereo Audio Processing	25
4.9. Received Signal Qualifiers	25
4.10. Volume Control	25
4.11. Stereo DAC	25
4.12. Soft Mute	25
4.13. FM Hi-Cut Control	25
4.14. De-emphasis	26
4.15. RDS/RBDS Processor (Si4731/35 Only)	26
4.16. Tuning	26
4.17. Seek	26
4.18. Reference Clock	26
4.19. Control Interface	27
4.20. GPO Outputs	28
4.21. Firmware Upgrades	28
4.22. Reset, Powerup, and Powerdown	28
4.23. 2 V Operation (SSOP Only)	28
4.24. Programming with Commands	28
<b>5. Pin Descriptions</b>	<b>29</b>
5.1. Si473x-D60-GM	29
5.2. Si473x-D60-GU	30
<b>6. Ordering Guide</b>	<b>31</b>
<b>7. Package Outline</b>	<b>32</b>
7.1. Si473x-D60 QFN	32
7.2. Si473x-D60 SSOP	33
<b>8. PCB Land Pattern</b>	<b>34</b>
8.1. Si473x-D60 QFN	34
8.2. Si473x-D60 SSOP	36

# Si4730/31/34/35-D60

---

- 9. Top Markings** .....37
  - 9.1. Si473x-D60 Top Marking (QFN) .....37
  - 9.2. Top Marking Explanation (QFN) .....37
  - 9.3. Si473x-D60 Top Marking (SSOP) .....38
  - 9.4. Top Marking Explanation (SSOP) .....38
- 10. Additional Reference Resources** .....39
- Document Change List** .....40
- Contact Information** .....42



## 1. Electrical Specifications

**Table 1. Recommended Operating Conditions<sup>1</sup>**

Parameter	Symbol	Test Condition	Min	Typ	Max	Unit
Analog Supply Voltage	$V_A$		2.7 <sup>2</sup>	—	5.5	V
Digital and I/O Supply Voltage	$V_D$		1.62	—	3.6	V
Power Supply Powerup Rise Time	$V_{DDRISE}$		10	—	—	$\mu$ s
Interface Power Supply Powerup Rise Time	$V_{IORISE}$		10	—	—	$\mu$ s
Ambient Temperature	$T_A$		-20	25	85	$^{\circ}$ C

**Notes:**

1. All minimum and maximum specifications apply across the recommended operating conditions. Typical values apply at  $V_A = 3.3$  V and 25  $^{\circ}$ C unless otherwise stated.
2. SSOP devices operate down to 2 V at 25  $^{\circ}$ C. See section “4.23. 2 V Operation (SSOP Only)” for details.

# Si4730/31/34/35-D60

**Table 2. DC Characteristics**

( $V_A = 2.7$  to  $5.5$  V,  $V_D = 1.62$  to  $3.6$  V,  $T_A = -20$  to  $85$  °C)

Parameter	Symbol	Test Condition	Min	Typ	Max	Unit
<b>FM Mode</b>						
$V_{AQFN}$ Supply Current	$I_{FMVA}$	Digital Output Mode <sup>1</sup>	—	8.2	9.5	mA
$V_{DQFN}$ Supply Current	$I_{FMVD}$		—	10.5	13.5	
$V_{ASSOP}$ Supply Current	$I_{FMVA}$		—	18.5	21.5	
$V_{DSSOP}$ Supply Current	$I_{FMVD}$		—	0.15	0.6	
$V_{AQFN}$ Supply Current	$I_{FMVA}$	Analog Output Mode <sup>2</sup>	—	9.1	10.3	
$V_{DQFN}$ Supply Current	$I_{FMVD}$		—	9.9	12.8	
$V_{ASSOP}$ Supply Current	$I_{FMVA}$		—	19.1	21.3	
$V_{DSSOP}$ Supply Current	$I_{FMVD}$		—	0.1	0.6	
<b>AM Mode</b>						
$V_{AQFN}$ Supply Current	$I_{AMVA}$	Digital Output Mode	—	6.5	7.5	mA
$V_{DQFN}$ Supply Current	$I_{AMVD}$		—	8.5	11.0	
$V_{ASSOP}$ Supply Current	$I_{AMVA}$		—	14.5	16.5	
$V_{DSSOP}$ Supply Current	$I_{AMVD}$		—	0.15	0.50	
$V_{AQFN}$ Supply Current	$I_{AMVA}$	Analog Output Mode	—	7.5	8.5	
$V_{DQFN}$ Supply Current	$I_{AMVD}$		—	8	10.2	
$V_{ASSOP}$ Supply Current	$I_{AMVA}$		—	15.3	17.2	
$V_{DSSOP}$ Supply Current	$I_{AMVD}$		—	0.1	0.4	
<b>Powerdown</b>						
$V_{AQFN}$ Powerdown Current	$I_{APD}$		—	4	15	μA
$V_{ASSOP}$ Powerdown Current			—	9.5	15	
$V_{DQFN}$ Powerdown Current	$I_{DPD}$	SCLK, RCLK inactive	—	3	10	μA
$V_{DSSOP}$ Powerdown Current		SCLK, RCLK inactive	—	3	10	
High Level Input Voltage <sup>3</sup>	$V_{IH}$		$0.7 \times V_D$	—	$V_D + 0.3$	V
Low Level Input Voltage <sup>3</sup>	$V_{IL}$		-0.3	—	$0.3 \times V_D$	V
High Level Input Current <sup>3</sup>	$I_{IH}$	$V_{IN} = V_D = 3.6$ V	-10	—	10	μA
Low Level Input Current <sup>3</sup>	$I_{IL}$	$V_{IN} = 0$ V, $V_D = 3.6$ V	-10	—	10	μA
High Level Output Voltage <sup>4</sup>	$V_{OH}$	$I_{OUT} = 500$ μA	$0.8 \times V_D$	—	—	V
Low Level Output Voltage <sup>4</sup>	$V_{OL}$	$I_{OUT} = -500$ μA	—	—	$0.2 \times V_D$	V

**Notes:**

1. Guaranteed by characterization.
2. Backwards compatible mode to rev B and rev C. Additional features on this device may increase typical supply current.
3. For input pins SCLK, SEN, SDIO, RST, RCLK, DCLK, DFS, GPO1, GPO2, and GPO3.
4. For output pins SDIO, DOUT, GPO1, GPO2, and GPO3.

**Table 3. Reset Timing Characteristics<sup>1,2,3</sup>** $(V_A = 2.7 \text{ to } 5.5 \text{ V}, V_D = 1.62 \text{ to } 3.6 \text{ V}, T_A = -20 \text{ to } 85 \text{ }^\circ\text{C})$ 

Parameter	Symbol	Min	Typ	Max	Unit
$\overline{\text{RST}}$ Pulse Width and GPO1, GPO2/ $\overline{\text{INT}}$ Setup to $\overline{\text{RST}}\uparrow^4$	$t_{\text{SRST}}$	100	—	—	$\mu\text{s}$
GPO1, GPO2/ $\overline{\text{INT}}$ Hold from $\overline{\text{RST}}\uparrow$	$t_{\text{HRST}}$	30	—	—	ns
$\overline{\text{RST}}$ Pulse Release time before VDD/VIO turn off	$t_{\text{RRST}}$	30	—	—	ns

**Important Notes:**

1. When selecting 2-wire mode, the user must ensure that a 2-wire start condition (falling edge of SDIO while SCLK is high) does not occur within 300 ns before the rising edge of  $\overline{\text{RST}}$ .
2. When selecting 2-wire mode, the user must ensure that SCLK is high during the rising edge of  $\overline{\text{RST}}$ , and stays high until after the first start condition.
3. When selecting 3-wire mode, the user must ensure that a rising edge of SCLK does not occur within 300 ns before the rising edge of  $\overline{\text{RST}}$ .
4. If GPO1 and GPO2 are actively driven by the user, then minimum  $t_{\text{SRST}}$  is only 30 ns. If GPO1 or GPO2 is hi-Z, then minimum  $t_{\text{SRST}}$  is 100  $\mu\text{s}$ , to provide time for on-chip 1 M $\Omega$  devices (active while  $\overline{\text{RST}}$  is low) to pull GPO1 high and GPO2 low.
5.  $\overline{\text{RST}}$  must be held low for at least 100  $\mu\text{s}$  after all voltage supplies have been ramped up.
6.  $\overline{\text{RST}}$  needs to be asserted (pulled low) prior to any supply voltage being ramped down.

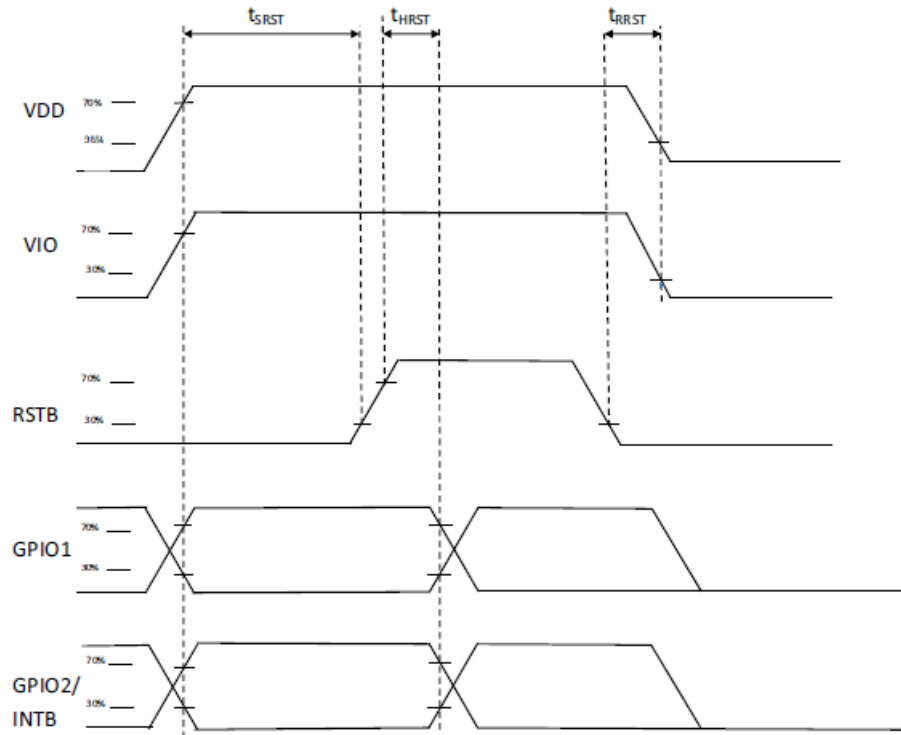
**Figure 1. Reset Timing Parameters for Busmode Select**

# Si4730/31/34/35-D60

**Table 4. 2-Wire Control Interface Characteristics<sup>1,2,3</sup>**

( $V_A = 2.7$  to  $5.5$  V,  $V_D = 1.62$  to  $3.6$  V,  $T_A = -20$  to  $85$  °C)

Parameter	Symbol	Test Condition	Min	Typ	Max	Unit
SCLK Frequency	$f_{SCL}$		0	—	400	kHz
SCLK Low Time	$t_{LOW}$		1.3	—	—	$\mu$ s
SCLK High Time	$t_{HIGH}$		0.6	—	—	$\mu$ s
SCLK Input to SDIO $\downarrow$ Setup (START)	$t_{SU:STA}$		0.6	—	—	$\mu$ s
SCLK Input to SDIO $\downarrow$ Hold (START)	$t_{HD:STA}$		0.6	—	—	$\mu$ s
SDIO Input to SCLK $\uparrow$ Setup	$t_{SU:DAT}$		100	—	—	ns
SDIO Input to SCLK $\downarrow$ Hold <sup>4,5</sup>	$t_{HD:DAT}$		0	—	900	ns
SCLK input to SDIO $\uparrow$ Setup (STOP)	$t_{SU:STO}$		0.6	—	—	$\mu$ s
STOP to START Time	$t_{BUF}$		1.3	—	—	$\mu$ s
SDIO Output Fall Time	$t_{f:OUT}$		$20 + 0.1 \frac{C_b}{1pF}$	—	250	ns
SDIO Input, SCLK Rise/Fall Time	$t_{f:IN}$ $t_{r:IN}$		$20 + 0.1 \frac{C_b}{1pF}$	—	300	ns
SCLK, SDIO Capacitive Loading	$C_b$		—	—	50	pF
Input Filter Pulse Suppression	$t_{SP}$		—	—	50	ns

**Notes:**

1. When  $V_D = 0$  V, SCLK and SDIO are low impedance.
2. When selecting 2-wire mode, the user must ensure that a 2-wire start condition (falling edge of SDIO while SCLK is high) does not occur within 300 ns before the rising edge of  $\overline{RST}$ .
3. When selecting 2-wire mode, the user must ensure that SCLK is high during the rising edge of  $\overline{RST}$ , and stays high until after the first start condition.
4. The Si473x-D60 delays SDIO by a minimum of 300 ns from the  $V_{IH}$  threshold of SCLK to comply with the minimum  $t_{HD:DAT}$  specification.
5. The maximum  $t_{HD:DAT}$  has only to be met when  $f_{SCL} = 400$  kHz. At frequencies below 400 KHz,  $t_{HD:DAT}$  may be violated as long as all other timing parameters are met.

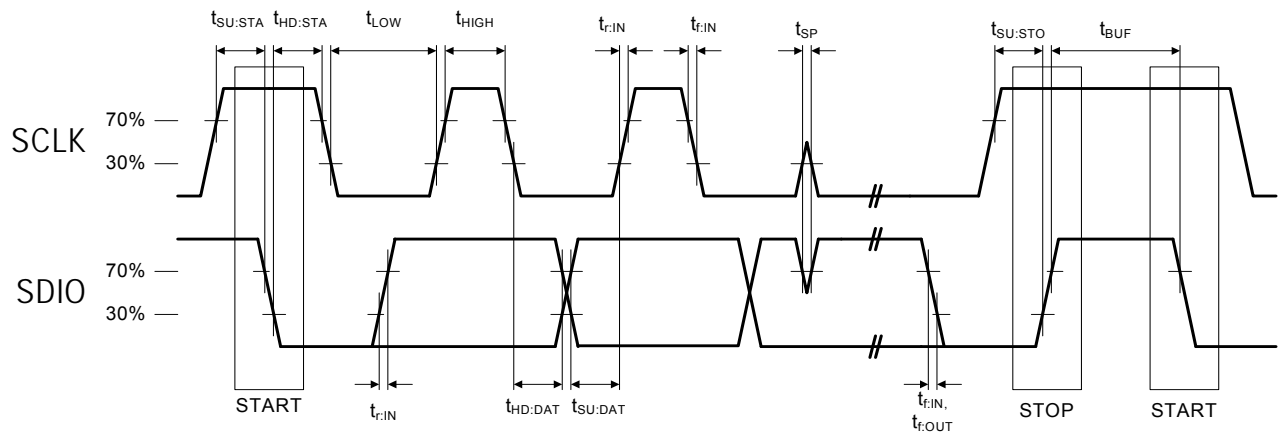

**Figure 2. 2-Wire Control Interface Read and Write Timing Parameters**

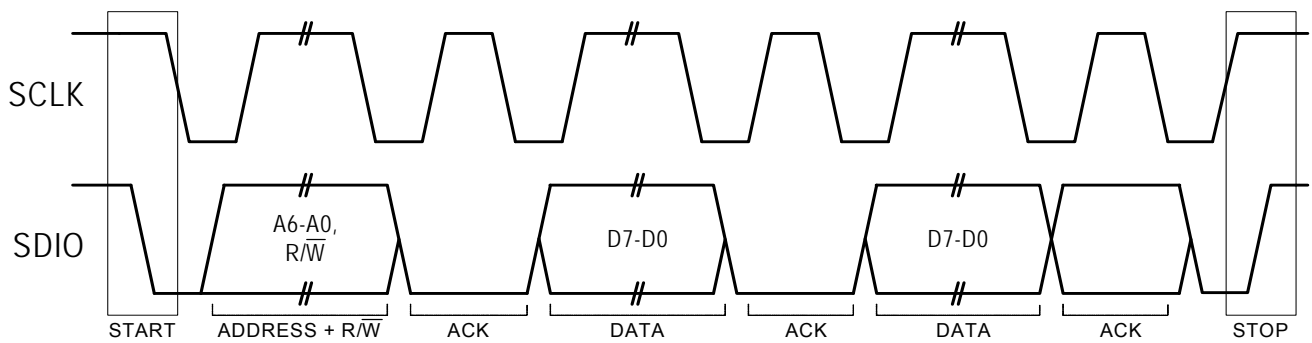

**Figure 3. 2-Wire Control Interface Read and Write Timing Diagram**

# Si4730/31/34/35-D60

**Table 5. 3-Wire Control Interface Characteristics**

( $V_A = 2.7$  to  $5.5$  V,  $V_D = 1.62$  to  $3.6$  V,  $T_A = -20$  to  $85$  °C)

Parameter	Symbol	Test Condition	Min	Typ	Max	Unit
SCLK Frequency	$f_{CLK}$		0	—	2.5	MHz
SCLK High Time	$t_{HIGH}$		25	—	—	ns
SCLK Low Time	$t_{LOW}$		25	—	—	ns
SDIO Input, $\overline{SEN}$ to SCLK $\uparrow$ Setup	$t_S$		20	—	—	ns
SDIO Input to SCLK $\uparrow$ Hold	$t_{HSDIO}$		10	—	—	ns
$\overline{SEN}$ Input to SCLK $\downarrow$ Hold	$t_{HSEN}$		10	—	—	ns
SCLK $\uparrow$ to SDIO Output Valid	$t_{CDV}$	Read	2	—	25	ns
SCLK $\uparrow$ to SDIO Output High Z	$t_{CDZ}$	Read	2	—	25	ns
SCLK, $\overline{SEN}$ , SDIO, Rise/Fall time	$t_R, t_F$		—	—	10	ns

**Note:** When selecting 3-wire mode, the user must ensure that a rising edge of SCLK does not occur within 300 ns before the rising edge of RST.

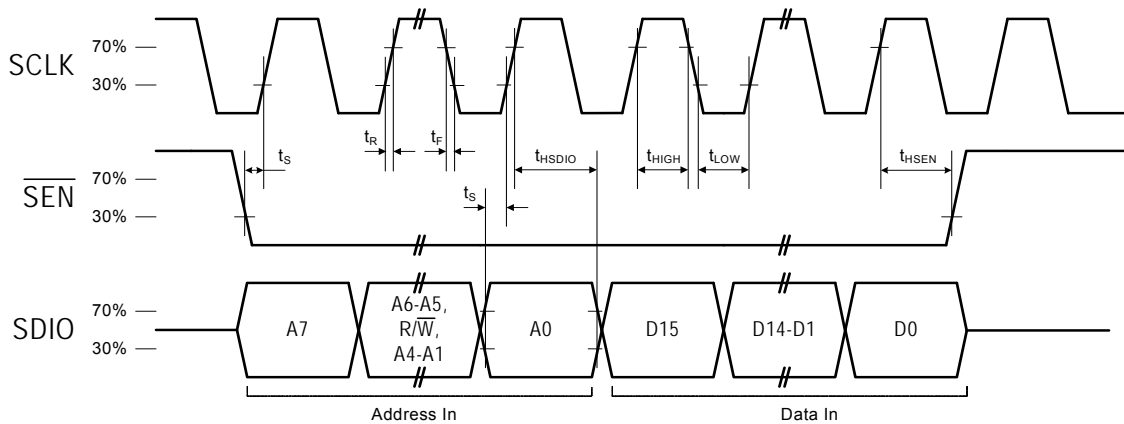

**Figure 4. 3-Wire Control Interface Write Timing Parameters**

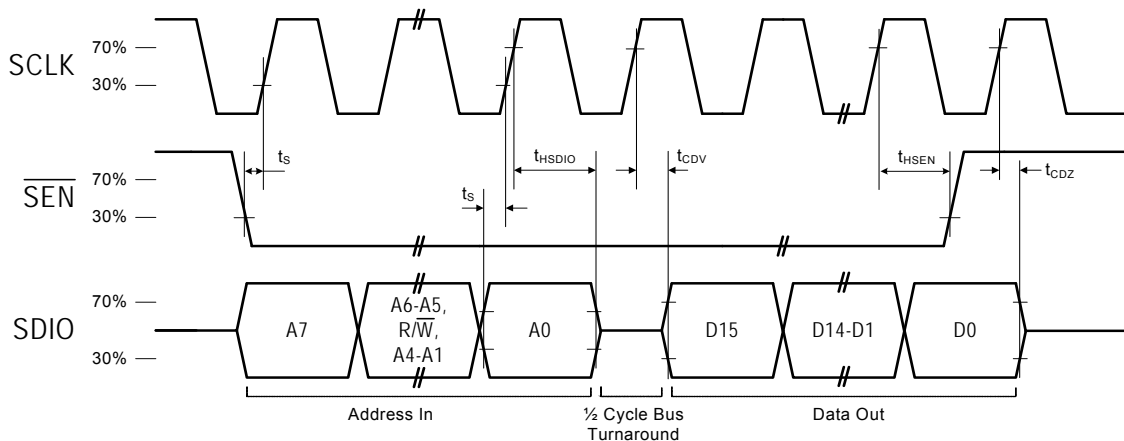

**Figure 5. 3-Wire Control Interface Read Timing Parameters**

**Table 6. Digital Audio Interface Characteristics** $(V_A = 2.7 \text{ to } 5.5 \text{ V}, V_D = 1.62 \text{ to } 3.6 \text{ V}, T_A = -20 \text{ to } 85 \text{ }^\circ\text{C})$ 

Parameter	Symbol	Test Condition	Min	Typ	Max	Unit
DCLK Cycle Time	$t_{DCT}$		26	—	1000	ns
DCLK Pulse Width High	$t_{DCH}$		10	—	—	ns
DCLK Pulse Width Low	$t_{DCL}$		10	—	—	ns
DFS Set-up Time to DCLK Rising Edge	$t_{SU:DFS}$		5	—	—	ns
DFS Hold Time from DCLK Rising Edge	$t_{HD:DFS}$		5	—	—	ns
DOUT Propagation Delay from DCLK Falling Edge	$t_{PD:DOUT}$		0	—	50	ns

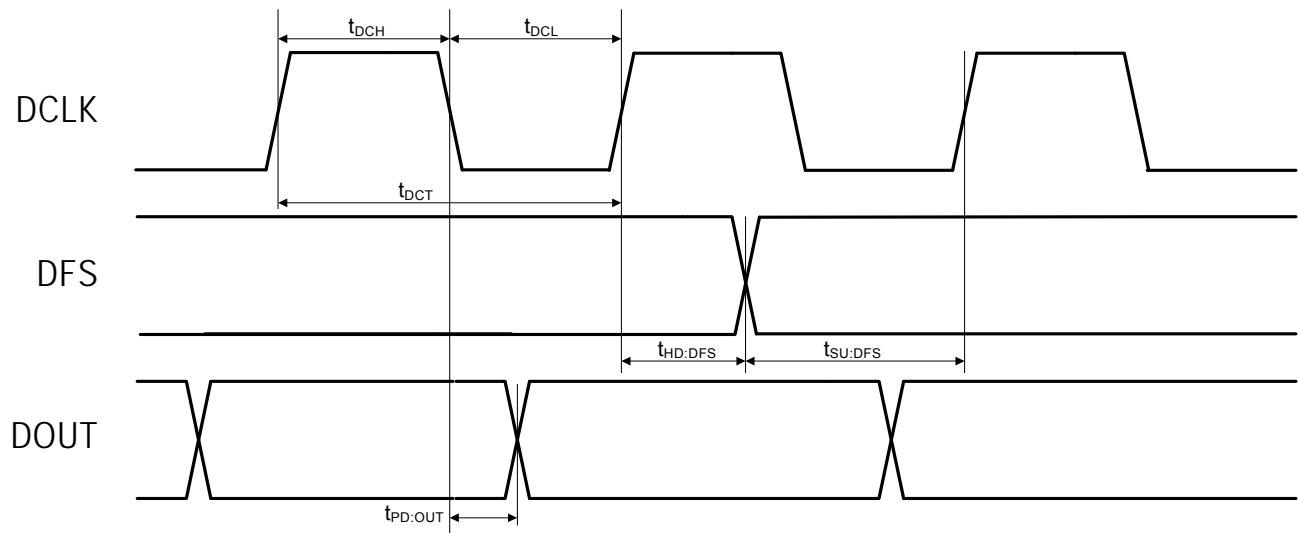
**Figure 6. Digital Audio Interface Timing Parameters, I<sup>2</sup>S Mode**

# Si4730/31/34/35-D60

**Table 7. FM Receiver Characteristics<sup>1,2</sup>**

( $V_A = 2.7$  to  $5.5$  V,  $V_D = 1.62$  to  $3.6$  V,  $T_A = -20$  to  $85$  °C)

Parameter	Symbol	Test Condition	Min	Typ	Max	Unit
Input Frequency	$f_{RF}$		76	—	108	MHz
Sensitivity <sup>3,4,5,6</sup>		(S+N)/N = 26 dB	—	2.2	3.5	$\mu$ V EMF
RDS Sensitivity <sup>6,7</sup>		$\Delta f = 2$ kHz, RDS BLER < 5%	—	10	—	$\mu$ V EMF
LNA Input Resistance <sup>7,8</sup>			3	4	5	k $\Omega$
LNA Input Capacitance <sup>7,8</sup>			4	5	6	pF
Input IP3 <sup>7,9</sup>			100	105	—	dB $\mu$ V EMF
AM Suppression <sup>3,4,7,8</sup>		m = 0.3	40	50	—	dB
Adjacent Channel Selectivity		$\pm 200$ kHz	35	50	—	dB
Alternate Channel Selectivity		$\pm 400$ kHz	60	70	—	dB
Spurious Response Rejection <sup>7</sup>		In-band	35	—	—	dB
Audio Output Voltage <sup>3,4,8</sup>			72	80	90	mV <sub>RMS</sub>
Audio Output L/R Imbalance <sup>3,8,10</sup>			—	—	1	dB
Audio Frequency Response Low <sup>7</sup>		-3 dB	—	—	30	Hz
Audio Frequency Response High <sup>7</sup>		-3 dB	15	—	—	kHz
Audio Stereo Separation <sup>8,10</sup>			35	42	—	dB
Audio Mono S/N <sup>3,4,5,8</sup>			55	63	—	dB
Audio Stereo S/N <sup>4,5,7,8</sup>			—	58	—	dB
Audio THD <sup>3,8,10</sup>			—	0.1	0.5	%
De-emphasis Time Constant <sup>7</sup>		FM_DEEMPHASIS = 2	70	75	80	$\mu$ s
		FM_DEEMPHASIS = 1	45	50	54	$\mu$ s
Blocking Sensitivity <sup>3,4,5,6,7,11,12</sup>		$\Delta f = \pm 400$ kHz	—	34	—	dB $\mu$ V
		$\Delta f = \pm 4$ MHz	—	30	—	dB $\mu$ V

**Notes:**

1. Additional testing information is available in “AN388: Si470x/1x/2x/3x/4x Evaluation Board Test Procedure.” Volume = maximum for all tests. Tested at RF = 98.1 MHz.
2. To ensure proper operation and receiver performance, follow the guidelines in “AN383: Si47xx Antenna, Schematic, Layout, and Design Guidelines.” Silicon Laboratories will evaluate schematics and layouts for qualified customers.
3.  $F_{MOD} = 1$  kHz, 75  $\mu$ s de-emphasis, MONO = enabled, and L = R unless noted otherwise.
4.  $\Delta f = 22.5$  kHz.
5.  $B_{AF} = 300$  Hz to 15 kHz, A-weighted.
6. Analog audio output mode.
7. Guaranteed by characterization.
8.  $V_{EMF} = 1$  mV.
9.  $|f_2 - f_1| > 2$  MHz,  $f_0 = 2 \times f_1 - f_2$ . AGC is disabled.
10.  $\Delta f = 75$  kHz.
11. Sensitivity measured at (S+N)/N = 26 dB.
12. Blocker Amplitude = 100 dBuV.
13. At temperature (25 °C).
14. At LOUT and ROUT pins.

**Table 7. FM Receiver Characteristics<sup>1,2</sup> (Continued)**(V<sub>A</sub> = 2.7 to 5.5 V, V<sub>D</sub> = 1.62 to 3.6 V, T<sub>A</sub> = -20 to 85 °C)

Parameter	Symbol	Test Condition	Min	Typ	Max	Unit
Intermod Sensitivity <sup>3,4,5,6,7,11,12</sup>		$\Delta f = \pm 400 \text{ kHz}, \pm 800 \text{ kHz}$	—	40	—	dB $\mu$ V
		$\Delta f = \pm 4 \text{ MHz}, \pm 8 \text{ MHz}$	—	35	—	dB $\mu$ V
Audio Output Load Resistance <sup>7,11,14</sup>	R <sub>L</sub>	Single-ended	10	—	—	k $\Omega$
Audio Output Load Capacitance <sup>7,11,14</sup>	C <sub>L</sub>	Single-ended	—	—	50	pF
Seek/Tune Time <sup>7</sup>		RCLK tolerance = 100 ppm	—	—	60	ms/channel
Powerup Time <sup>7</sup>		From powerdown	—	—	110	ms
RSSI Offset <sup>12,13</sup>		Input levels of 8 and 60 dB $\mu$ V at RF Input	-3	—	3	dB

**Notes:**

1. Additional testing information is available in "AN388: Si470x/1x/2x/3x/4x Evaluation Board Test Procedure." Volume = maximum for all tests. Tested at RF = 98.1 MHz.
2. To ensure proper operation and receiver performance, follow the guidelines in "AN383: Si47xx Antenna, Schematic, Layout, and Design Guidelines." Silicon Laboratories will evaluate schematics and layouts for qualified customers.
3. F<sub>MOD</sub> = 1 kHz, 75  $\mu$ s de-emphasis, MONO = enabled, and L = R unless noted otherwise.
4.  $\Delta f = 22.5 \text{ kHz}$ .
5. B<sub>AF</sub> = 300 Hz to 15 kHz, A-weighted.
6. Analog audio output mode.
7. Guaranteed by characterization.
8. V<sub>EMF</sub> = 1 mV.
9.  $|f_2 - f_1| > 2 \text{ MHz}$ , f<sub>0</sub> = 2 x f<sub>1</sub> - f<sub>2</sub>. AGC is disabled.
10.  $\Delta f = 75 \text{ kHz}$ .
11. Sensitivity measured at (S+N)/N = 26 dB.
12. Blocker Amplitude = 100 dBuV.
13. At temperature (25 °C).
14. At LOUT and ROUT pins.

# Si4730/31/34/35-D60

**Table 8. 64–75.9 MHz Input Frequency FM Receiver Characteristics<sup>1,2,3</sup>**

( $V_A = 2.7$  to  $5.5$  V,  $V_D = 1.62$  to  $3.6$  V,  $T_A = -20$  to  $85$  °C)

Parameter	Symbol	Test Condition	Min	Typ	Max	Unit
Input Frequency	$f_{RF}$		64	—	75.9	MHz
Sensitivity <sup>4,5,6,8</sup>		(S+N)/N = 26 dB	—	3.5	—	$\mu$ V EMF
LNA Input Resistance <sup>3,7</sup>			3	4	5	k $\Omega$
LNA Input Capacitance <sup>3,7</sup>			4	5	6	pF
Input IP3 <sup>9</sup>			—	105	—	dB $\mu$ V EMF
AM Suppression <sup>3,4,5,7</sup>		m = 0.3	—	50	—	dB
Adjacent Channel Selectivity		$\pm$ 200 kHz	—	50	—	dB
Alternate Channel Selectivity		$\pm$ 400 kHz	—	70	—	dB
Audio Output Voltage <sup>4,5,7</sup>			72	80	90	mV <sub>RMS</sub>
Audio Output L/R Imbalance <sup>4,7,10</sup>			—	—	1	dB
Audio Frequency Response Low <sup>3</sup>		-3 dB	—	—	30	Hz
Audio Frequency Response High <sup>3</sup>		-3 dB	15	—	—	kHz
Audio Mono S/N <sup>4,3,5,7,11</sup>			—	63	—	dB
Audio THD <sup>4,7,10</sup>			—	0.1	—	%
De-emphasis Time Constant		FM_DEEMPHASIS = 2	70	75	80	$\mu$ s
		FM_DEEMPHASIS = 1	45	50	54	$\mu$ s
Audio Output Load Resistance <sup>3,11</sup>	$R_L$	Single-ended	10	—	—	k $\Omega$
Audio Output Load Capacitance <sup>3,11</sup>	$C_L$	Single-ended	—	—	50	pF
Seek/Tune Time <sup>3</sup>		RCLK tolerance = 100 ppm	—	—	60	ms/channel
Powerup Time <sup>3</sup>		From powerdown	—	—	110	ms
RSSI Offset <sup>12</sup>		Input levels of 8 and 60 dB $\mu$ V EMF	-3	—	3	dB

**Notes:**

1. Additional testing information is available in “AN388: Si470x/1x/2x/3x/4x Evaluation Board Test Procedure.” Volume = maximum for all tests. Tested at RF = 98.1 MHz.
2. To ensure proper operation and receiver performance, follow the guidelines in “AN383: Si47xx Antenna, Schematic, Layout, and Design Guidelines.” Silicon Laboratories will evaluate schematics and layouts for qualified customers.
3. Guaranteed by characterization.
4.  $F_{MOD} = 1$  kHz, 75  $\mu$ s de-emphasis, MONO = enabled, and L = R unless noted otherwise.
5.  $\Delta f = 22.5$  kHz.
6.  $B_{AF} = 300$  Hz to 15 kHz, A-weighted.
7.  $V_{EMF} = 1$  mV.
8. Analog output mode.
9.  $|f_2 - f_1| > 2$  MHz,  $f_0 = 2 \times f_1 - f_2$ . AGC is disabled.
10.  $\Delta f = 75$  kHz.
11. At LOUT and ROUT pins.
12. At temperature (25 °C).

**Table 9. AM/SW/LW Receiver Characteristics<sup>1,2</sup>**(V<sub>A</sub> = 2.7 to 5.5 V, V<sub>A</sub> = 1.62 to 3.6 V, T<sub>A</sub> = -20 to 85 °C)

Parameter	Symbol	Test Condition	Min	Typ	Max	Unit
Input Frequency	f <sub>RF</sub>	Long Wave (LW)	153	—	279	kHz
		Medium Wave (AM)	520	—	1710	kHz
		Short Wave (SW)	2.3	—	26.1	MHz
Sensitivity <sup>3,4,5</sup>		(S+N)/N = 26 dB	—	25	35	μV EMF
Large Signal Voltage Handling <sup>5,6</sup>		THD < 8%	—	300	—	mV <sub>RMS</sub>
Power Supply Rejection Ratio <sup>5</sup>		ΔV <sub>DD</sub> = 100 mV <sub>RMS</sub> , 100 Hz	—	40	—	dB
Audio Output Voltage <sup>3,7</sup>			54	60	67	mV <sub>RMS</sub>
Audio S/N <sup>3,4,7</sup>			—	60	—	dB
Audio THD <sup>3,7</sup>			—	0.1	0.5	%
Antenna Inductance <sup>5,8</sup>		Long Wave (LW)	—	2800	—	μH
		Medium Wave (AM)	180	—	450	μH
Powerup Time <sup>5</sup>		From powerdown	—	—	110	ms

**Notes:**

1. Additional testing information is available in “AN388: Si470x/1x/2x/3x/4x Evaluation Board Test Procedure.”  
Volume = maximum for all tests. Tested at RF = 520 kHz.
2. To ensure proper operation and receiver performance, follow the guidelines in “AN383: Si47xx Antenna, Schematic, Layout, and Design Guidelines.” Silicon Laboratories will evaluate schematics and layouts for qualified customers.
3. FMOD = 1 kHz, 30% modulation, 2 kHz channel filter.
4. B<sub>AF</sub> = 300 Hz to 15 kHz, A-weighted.
5. Guaranteed by characterization.
6. See “AN388: Si470x/1x/2x/3x/4x Evaluation Board Test Procedure” for evaluation method.
7. V<sub>IN</sub> = 5 mVrms.
8. Stray capacitance on antenna and board must be < 10 pF to achieve full tuning range at higher inductance levels.

# Si4730/31/34/35-D60

**Table 10. Reference Clock and Crystal Characteristics**

( $V_A = 2.7$  to  $5.5$  V,  $V_D = 1.62$  to  $3.6$  V,  $T_A = -20$  to  $85$  °C)

Parameter	Symbol	Test Condition	Min	Typ	Max	Unit
<b>Reference Clock</b>						
RCLK Supported Frequencies <sup>1</sup>			31.130	32.768	40,000	kHz
RCLK Frequency Tolerance <sup>2</sup>			-100	—	100	ppm
REFCLK_PRESCALE			1	—	4095	
REFCLK			31.130	32.768	34.406	kHz
<b>Crystal Oscillator</b>						
Crystal Oscillator Frequency			—	32.768	—	kHz
Crystal Frequency Tolerance <sup>2</sup>			-100	—	100	ppm
Board Capacitance			—	—	3.5	pF
ESR			—	—	50	$\kappa\Omega$
CL <sup>3</sup>			7	12	22	pF
CL—single ended <sup>3</sup>			14	24	44	pF
<b>Notes:</b>						
1. The Si473x-D60 divides the RCLK input by REFCLK_PRESCALE to obtain REFCLK. There are some RCLK frequencies between 31.130 kHz and 40 MHz that are not supported. For more details, see Table 6 of “AN332: Si47xx Programming Guide”.						
2. A frequency tolerance of $\pm 50$ ppm is required for FM seek/tune using 50 kHz channel spacing and AM seek/tune in SW frequencies.						
3. Guaranteed by characterization.						

**Table 11. Thermal Conditions**

Parameter	Symbol	Min	Typ	Max	Unit
Thermal Resistance*	$\theta_{JA}$	—	80	—	°C/W
Ambient Temperature	$T_A$	-20	25	85	°C
Junction Temperature	$T_J$	—	—	92	°C

**\*Note:** Thermal resistance assumes a multi-layer PCB with the exposed pad soldered to a topside PCB pad.

Table 12. Absolute Maximum Ratings<sup>1,2</sup>

Parameter	Symbol	Value	Unit
Analog Supply Voltage	$V_A$	-0.5 to 5.8	V
Digital and I/O Supply Voltage	$V_D$	-0.5 to 3.9	V
Input Current <sup>3</sup>	$I_{IN}$	10	mA
Input Voltage <sup>3</sup>	$V_{IN}$	-0.3 to ( $V_{IO} + 0.3$ )	V
Operating Temperature	$T_{OP}$	-40 to 95	°C
Storage Temperature	$T_{STG}$	-55 to 150	°C
RF Input Level <sup>4</sup>		0.4	$V_{pk}$

**Notes:**

1. Permanent device damage may occur if the above Absolute Maximum Ratings are exceeded. Functional operation should be restricted to the conditions as specified in the operational sections of this data sheet. Exposure beyond recommended operating conditions for extended periods may affect device reliability.
2. The Si473x-D60 devices are high-performance RF integrated circuits with certain pins having an ESD rating of < 2 kV HBM. Handling and assembly of these devices should only be done at ESD-protected workstations.
3. For input pins DFS, SCLK, SEN, SDIO, RST, RCLK, GPO1, GPO2, GPO3, and DCLK.
4. At RF input pins FMI and AMI.

# Si4730/31/34/35-D60

## 2. Typical Application Schematic

### 2.1. QFN Typical Application Schematic

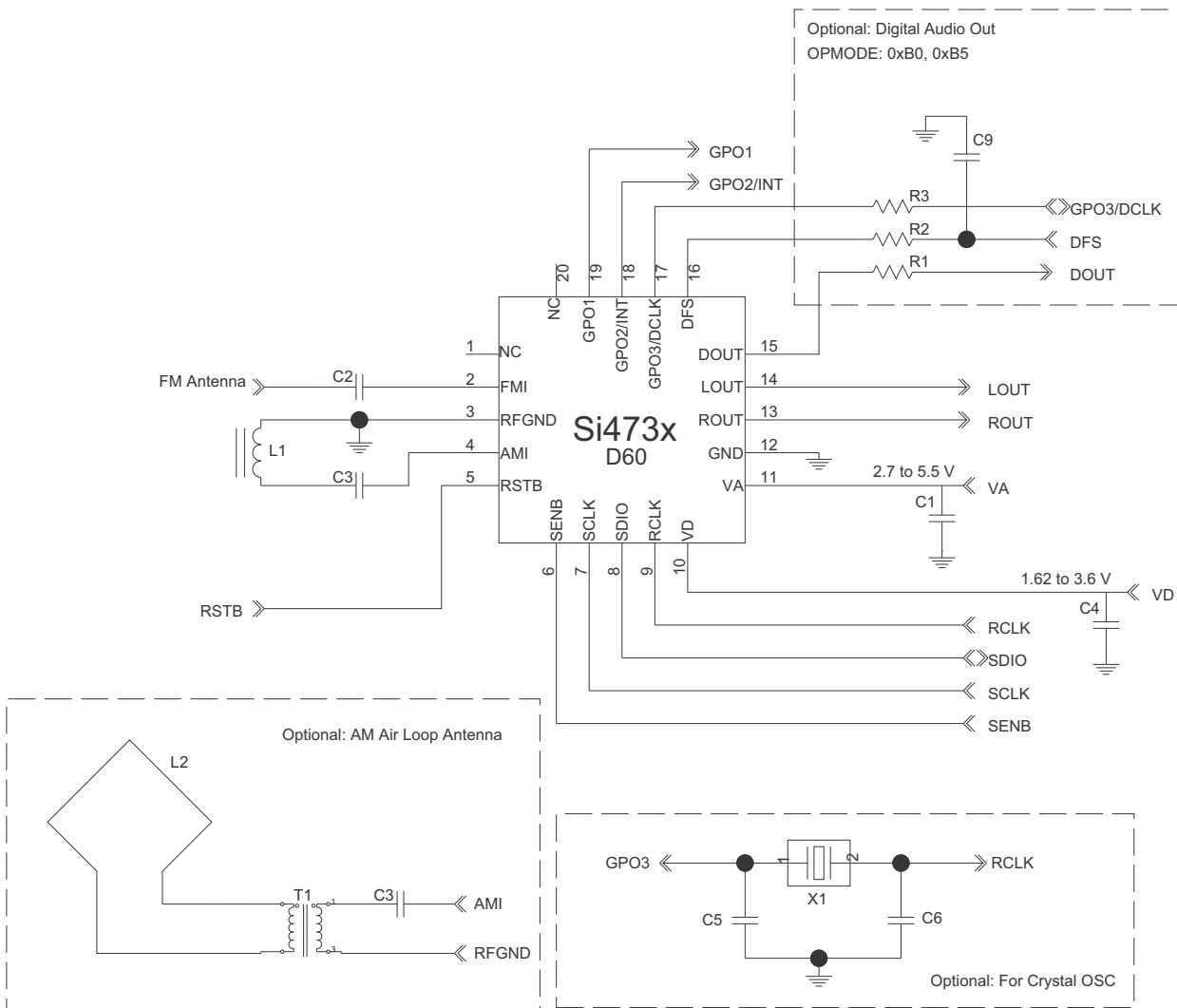

#### Notes:

1. Place C1 close to VA pin and C4 close to VD pin.
2. All grounds connect directly to GND plane on PCB.
3. Pins 1 and 20 are no connects, leave floating.
4. To ensure proper operation and receiver performance, follow the guidelines in "AN383: Si47xx Antenna, Schematic, Layout, and Design Guidelines." Silicon Laboratories will evaluate schematics and layouts for qualified customers.
5. Pin 2 connects to the FM antenna interface, and pin 4 connects to the AM antenna interface.
6. Place Si473x-D60 as close as possible to antenna and keep the FMI and AMI traces as short as possible.

## 2.2. SSOP Typical Application Schematic

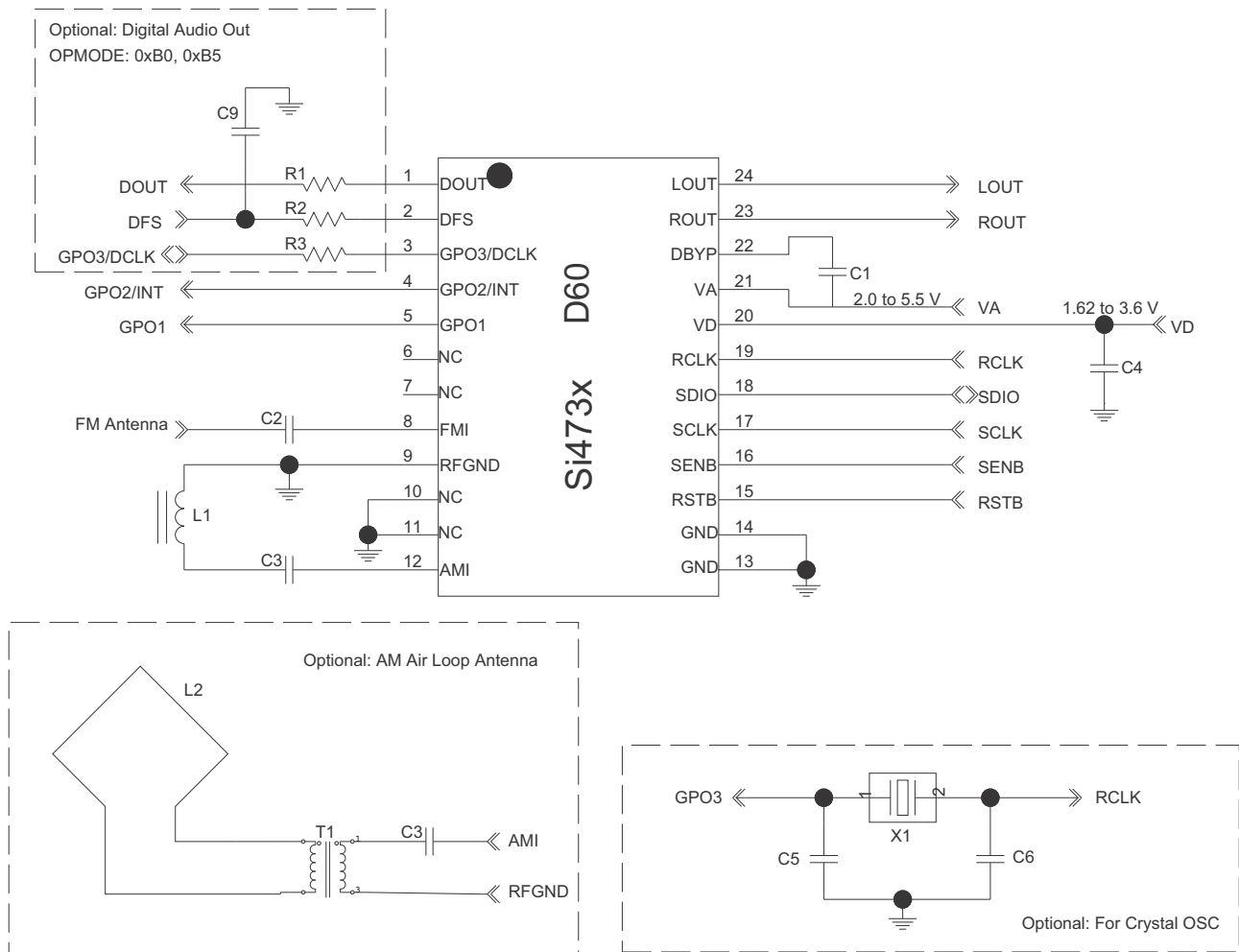

### Notes:

1. Place C1 close to VA and C4 close to VD pin.
2. All grounds connect directly to GND plane on PCB.
3. Pins 6 and 7 are no connects, leave floating.
4. Pins 10 and 11 are unused. Tie these pins to GND.
5. To ensure proper operation and receiver performance, follow the guidelines in "AN383: Si47xx Antenna, Schematic, Layout, and Design Guidelines." Silicon Laboratories will evaluate schematics and layouts for qualified customers.
6. Pin 8 connects to the FM antenna interface, and pin 12 connects to the AM antenna interface.
7. Place Si473x-D60 as close as possible to antenna and keep the FMI and AMI traces as short as possible.

# Si4730/31/34/35-D60

## 3. Bill of Materials

### 3.1. QFN/SSOP Bill of Materials

Table 13. Si473x-D60 QFN/SSOP Bill of Materials

Component(s)	Value/Description	Supplier
C1	Supply bypass capacitor, 22 nF, $\pm 20\%$ , Z5U/X7R	Murata
C2	Coupling capacitor, 1 nF, $\pm 20\%$ , Z5U/X7R	Murata
C3	Coupling capacitor, 0.47 $\mu$ F, $\pm 20\%$ , Z5U/X7R	Murata
C4	Supply bypass capacitor, 100 nF, 10%, Z5U/X7R	Murata
L1	Ferrite loop stick, 180–450 $\mu$ H	Jiixin
U1	Si47xx AM/FM Radio Tuner	Silicon Laboratories
<b>Optional Components</b>		
C5, C6	Crystal load capacitors, 22 pF, $\pm 5\%$ , COG (Optional for crystal oscillator)	Venkel
C9	Noise mitigating capacitor, 2~5 pF (Optional for digital audio)	Murata
R1	Resistor, 600 $\Omega$ (Optional for digital audio)	Venkel
R2	Resistor, 2 k $\Omega$ (Optional for digital audio)	Venkel
R3	Resistor, 2 k $\Omega$ (Optional for digital audio)	Venkel
L2	Air Loop, 10-20 $\mu$ H (Optional for AM Input)	Jiixin
T1	Transformer, 1:5 turns ratio (Optional for AM Input)	Jiixin, UMEC
X1	32.768 kHz crystal (Optional for crystal oscillator)	Epson

## 4. Functional Description

### 4.1. Overview

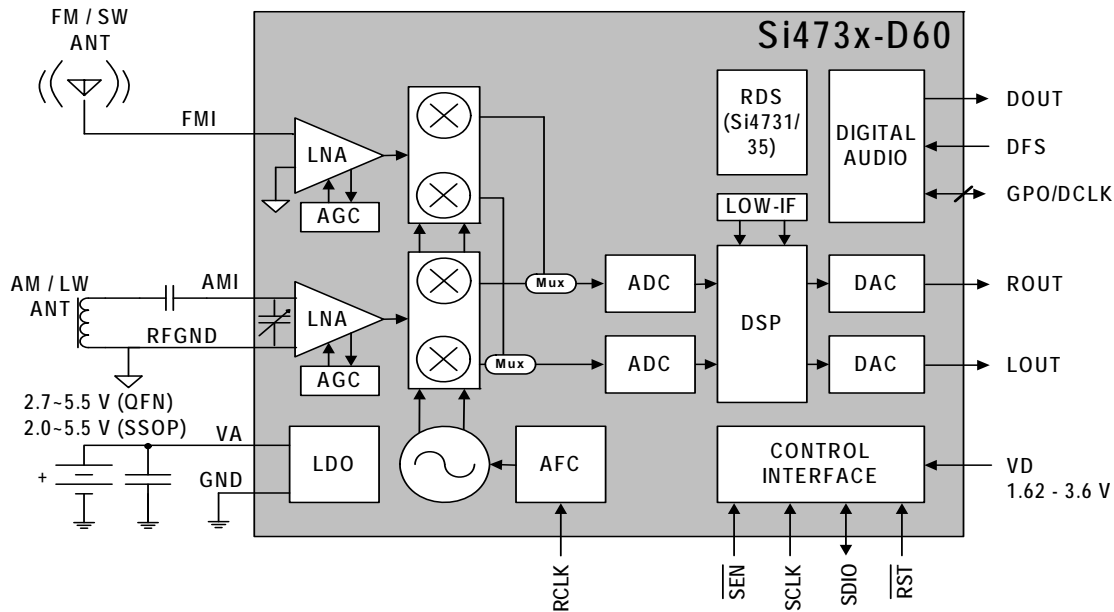

**Figure 7. Functional Block Diagram**

The Si473x-D60 digital CMOS AM/FM radio receiver IC integrates the complete broadcast tuner and receiver function from antenna input to digital audio output. The device leverages the Silicon Labs broadcast proven digital low-IF architecture, enabling a cost-effective digital audio platform for consumer electronic applications with high TDMA noise immunity, superior radio performance, and high fidelity audio power amplification. Offering unmatched integration and PCB space savings, the Si473x-D60 requires only a few external components and less than 15 mm<sup>2</sup> of board area, excluding the antenna inputs. The Si473x-D60 AM/FM radio provides the space savings and low power consumption necessary for portable devices while delivering the high performance and design simplicity desired for all AM/FM solutions.

Leveraging Silicon Laboratories' proven and patented Si4700/01 FM tuner's digital low intermediate frequency (low-IF) receiver architecture, the Si473x-D60 delivers superior RF performance and interference rejection in the AM, FM, SW, and LW bands. The high level of integration and complete system production test simplifies design-in, increases system quality, and improves reliability and manufacturability.

The Si473x-D60 is a feature-rich solution that includes advanced seek algorithms, soft mute, auto-calibrated digital tuning, FM stereo processing and advanced

audio processing.

In addition, the Si473x-D60 provides analog and digital audio outputs and a programmable reference clock. The device supports I<sup>2</sup>C-compatible 2-wire control interface, and a Si4700/01 backwards-compatible 3-wire control interface.

The Si473x-D60 utilizes digital signal processing to achieve high fidelity, optimal performance, and design flexibility. The chip provides excellent pilot rejection, selectivity, and unmatched audio performance, and offers both the manufacturer and the end-user extensive programmability and a better listening experience.

The Si4731/35 incorporates a digital signal processor for the European Radio Data System (RDS) and the North American Radio Broadcast Data System (RBDS) including all required symbol decoding, block synchronization, error detection, and error correction functions. Using this feature, the Si4731/35 enables broadcast data such as station identification and song name to be displayed to the user.

## 4.2. Operating Modes

The Si473x-D60 operates in either an FM receive or AM receive modes. In FM mode, radio signals are received on FMI and processed by the FM front-end circuitry. In AM mode, radio signals are received on AMI and processed by the AM front-end circuitry. In addition to the receiver mode, there is a clocking mode to choose to clock the Si473x-D60 from a reference clock or crystal. On the Si473x-D60, there is an audio output mode to choose between an analog and/or digital audio output. In the analog audio output mode, ROUT and LOUT are used for the audio output pins. In the digital audio mode, DOUT, DFS, and DCLK pins are used. Concurrent analog/digital audio output mode is also available requiring all five pins.

## 4.3. FM Receiver

The Si473x-D60 FM receiver is based on the proven Si4700/01 FM tuner. The receiver uses a digital low-IF architecture allowing the elimination of external components and factory adjustments. The Si473x-D60 integrates a low noise amplifier (LNA) supporting the worldwide FM broadcast band (64 to 108 MHz). An AGC circuit controls the gain of the LNA to optimize sensitivity and rejection of strong interferers. An image-reject mixer downconverts the RF signal to low-IF. The quadrature mixer output is amplified, filtered, and digitized with high resolution analog-to-digital converters (ADCs). This advanced architecture allows the Si473x-D60 to perform channel selection, FM demodulation, and stereo audio processing to achieve superior performance compared to traditional analog architectures.

## 4.4. AM Receiver

The highly-integrated Si473x-D60 supports worldwide AM band reception from 520 to 1710 kHz using a digital low-IF architecture with a minimum number of external components and no manual alignment required. This digital low-IF architecture allows for high-precision filtering offering excellent selectivity and SNR with minimum variation across the AM band. The DSP also provides adjustable channel step sizes in 1 kHz increments, AM demodulation, soft mute, seven different channel bandwidth filters, and additional features, such as a programmable automatic volume control (AVC) maximum gain allowing users to adjust the level of background noise.

Similar to the FM receiver, the integrated LNA and AGC optimize sensitivity and rejection of strong interferers allowing better reception of weak stations.

The Si473x-D60 provides highly-accurate digital AM tuning without factory adjustments. To offer maximum flexibility, the receiver supports a wide range of ferrite loop sticks from 180–450  $\mu$ H. An air loop antenna is supported by using a transformer to increase the effective inductance from the air loop. Using a 1:5 turn ratio inductor, the inductance is increased by 25 times and easily supports all typical AM air loop antennas which generally vary between 10 and 20  $\mu$ H.

## 4.5. SW Receiver

The Si4734/35 is the first fully integrated IC to support AM and FM, as well as short wave (SW) band reception from 2.3 to 26.1 MHz fully covering the 120 meter to 11 meter bands. The Si4734/35 offers extensive shortwave features such as continuous digital tuning with minimal discrete components and no factory adjustments. Other SW features include adjustable channel step sizes in 1 kHz increments, adjustable channel bandwidth settings, advanced seek algorithm, and soft mute.

The Si4734/35 uses the FM antenna to capture short wave signals. These signals are then fed directly into the AMI pin in a wide band configuration. See "AN332: Si47xx Programming Guide" and "AN383: Si47xx Antenna and Schematic Guidelines" for more details.

## 4.6. LW Receiver

The Si4734/35 supports the long wave (LW) band from 153 to 279 kHz. The highly integrated Si4734/35 offers continuous digital tuning with minimal discrete components and no factory adjustments. The Si4734/35 also offers adjustable channel step sizes in 1 kHz increments, adjustable channel bandwidth settings, advanced seek algorithm, and soft mute.

The Si4734/35 uses a separate ferrite bar antenna to capture long wave signals.

## 4.7. Digital Audio Interface

The digital audio interface operates in slave mode and supports a variety of MSB-first audio data formats including I2S and left-justified modes. The interface has three pins: digital data input (DIN), digital frame synchronization input (DFS), and a digital bit synchronization input clock (DCLK). The Si473x-D60 supports a number of industry-standard sampling rates including 32, 44.1, and 48 kHz. The digital audio interface enables low-power operation by eliminating the need for redundant DACs and ADCs on the audio baseband processor.

### 4.7.1. Audio Data Formats

The digital audio interface operates in slave mode and supports three different audio data formats:

- I2S
- Left-Justified
- DSP Mode

In I2S mode, by default the MSB is captured on the second rising edge of DCLK following each DFS transition. The remaining bits of the word are sent in order, down to the LSB. The left channel is transferred first when the DFS is low, and the right channel is transferred when the DFS is high.

In left-justified mode, by default the MSB is captured on the first rising edge of DCLK following each DFS transition. The remaining bits of the word are sent in order, down to the LSB. The left channel is transferred first when the DFS is high, and the right channel is transferred when the DFS is low.

In DSP mode, the DFS becomes a pulse with a width of 1DCLK period. The left channel is transferred first, followed right away by the right channel. There are two options in transferring the digital audio data in DSP mode: the MSB of the left channel can be transferred on the first rising edge of DCLK following the DFS pulse or on the second rising edge.

In all audio formats, depending on the word size, DCLK frequency, and sample rates, there may be unused DCLK cycles after the LSB of each word before the next DFS transition and MSB of the next word. In addition, if preferred, the user can configure the MSB to be captured on the falling edge of DCLK via properties. The number of audio bits can be configured for 8, 16, 20, or 24 bits.

### 4.7.2. Audio Sample Rates

The device supports a number of industry-standard sampling rates including 32, 44.1, and 48 kHz. The digital audio interface enables low-power operation by eliminating the need for redundant DACs on the audio baseband processor.

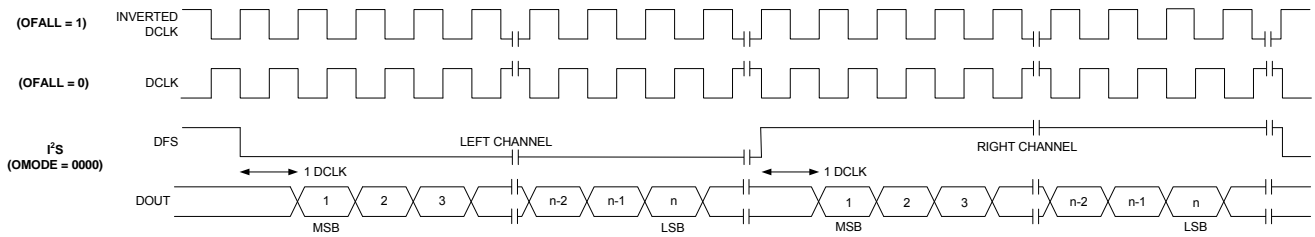

**Figure 8. I2S Digital Audio Format**

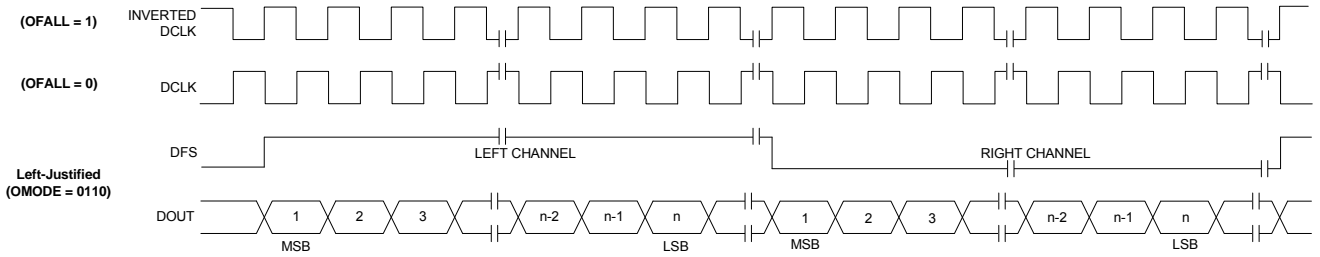

**Figure 9. Left-Justified Digital Audio Format**

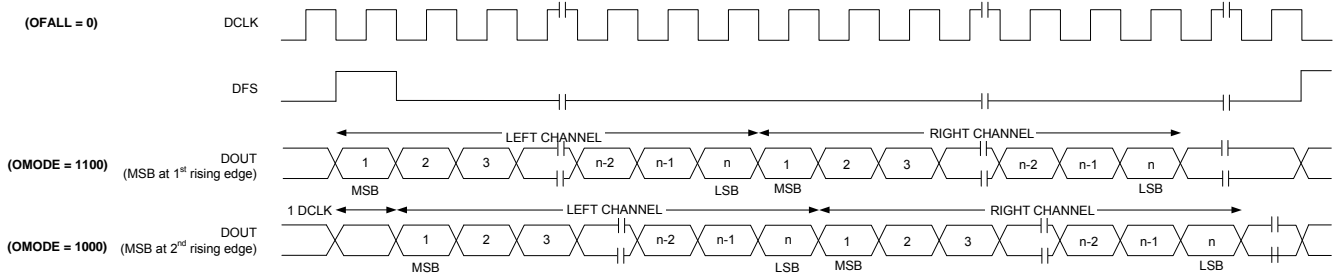

**Figure 10. DSP Digital Audio Format**

## 4.8. Stereo Audio Processing

The output of the FM demodulator is a stereo multiplexed (MPX) signal. The MPX standard was developed in 1961, and is used worldwide. Today's MPX signal format consists of left + right (L+R) audio, left – right (L–R) audio, a 19 kHz pilot tone, and RDS/RBDS data as shown in Figure 11 below.

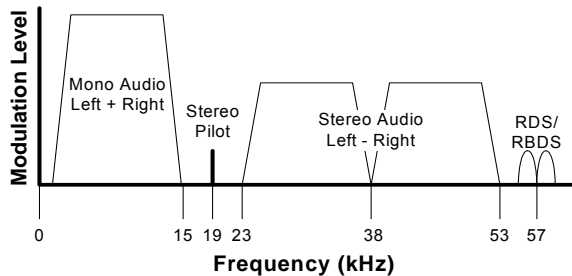

Figure 11. MPX Signal Spectrum

### 4.8.1. Stereo Decoder

The Si473x-D60's integrated stereo decoder automatically decodes the MPX signal using DSP techniques. The 0 to 15 kHz (L+R) signal is the mono output of the FM tuner. Stereo is generated from the (L+R), (L–R), and a 19 kHz pilot tone. The pilot tone is used as a reference to recover the (L–R) signal. Output left and right channels are obtained by adding and subtracting the (L+R) and (L–R) signals respectively.

### 4.8.2. Stereo-Mono Blending

Adaptive noise suppression is employed to gradually combine the stereo left and right audio channels to a mono (L+R) audio signal as the signal quality degrades to maintain optimum sound fidelity under varying reception conditions. Three metrics, received signal strength indicator (RSSI), signal-to-noise ratio (SNR), and multipath interference, are monitored simultaneously in forcing a blend from stereo to mono. The metric which reflects the minimum signal quality takes precedence and the signal is blended appropriately.

All three metrics have programmable stereo/mono thresholds and attack/release rates. If a metric falls below its mono threshold, the signal is blended from stereo to full mono. If all metrics are above their respective stereo thresholds, then no action is taken to blend the signal. If a metric falls between its mono and stereo thresholds, then the signal is blended to the level proportional to the metric's value between its mono and stereo thresholds, with an associated attack and release rate.

## 4.9. Received Signal Qualifiers

The quality of a tuned signal can vary depending on many factors including environmental conditions, time of day, and position of the antenna. To adequately manage the audio output and avoid unpleasant audible effects to the end-user, the Si473x-D60 monitors and provides indicators of the signal quality, allowing the host processor to perform additional processing if required by the customer. The Si473x-D60 monitors signal quality metrics including RSSI, SNR, and multipath interference on FM signals. These metrics are used to optimize signal processing and are also reported to the host processor. The signal processing algorithms can use either Silicon Labs' optimized settings (recommended) or be customized to modify performance.

### 4.10. Volume Control

The audio output may be muted. Volume is adjusted digitally by the RX\_VOLUME property.

### 4.11. Stereo DAC

High-fidelity stereo digital-to-analog converters (DACs) drive analog audio signals onto the LOUT and ROUT pins. The audio output may be muted.

### 4.12. Soft Mute

The soft mute feature is available to attenuate the audio outputs and minimize audible noise in very weak signal conditions. The soft mute feature is triggered by the SNR metric. The SNR threshold for activating soft mute is programmable, as are soft mute attenuation levels and attack and release rates.

### 4.13. FM Hi-Cut Control

Hi-cut control is employed on audio outputs with degradation of the signal due to low SNR and/or multipath interference. Two metrics, SNR and multipath interference, are monitored concurrently in forcing hi-cut of the audio outputs. Programmable minimum and maximum thresholds are available for both metrics. The transition frequency for hi-cut is also programmable with up to seven hi-cut filter settings. A single set of attack and release rates for hi-cut are programmable for both metrics from a range of 2 ms to 64 s. The level of hi-cut applied can be monitored with the FM\_RSQ\_STATUS command. Hi-cut can be disabled by setting the hi-cut filter to audio bandwidth of 15 kHz.

## 4.14. De-emphasis

Pre-emphasis and de-emphasis is a technique used by FM broadcasters to improve the signal-to-noise ratio of FM receivers by reducing the effects of high-frequency interference and noise. When the FM signal is transmitted, a pre-emphasis filter is applied to accentuate the high audio frequencies. The Si473x-D60 incorporates a de-emphasis filter which attenuates high frequencies to restore a flat frequency response. Two time constants are used in various regions. The de-emphasis time constant is programmable to 50 or 75  $\mu$ s and is set by the FM\_DEEMPHASIS property.

## 4.15. RDS/RBDS Processor (Si4731/35 Only)

The Si4731/35 implements an RDS/RBDS\* processor for symbol decoding, block synchronization, error detection, and error correction.

The Si4731/35 device is user configurable and provides an optional interrupt when RDS is synchronized, loses synchronization, and/or the user configurable RDS FIFO threshold has been met.

The Si4731/35 reports RDS decoder synchronization status and detailed bit errors in the information word for each RDS block with the FM\_RDS\_STATUS command. The range of reportable block errors is 0, 1–2, 3–5, or 6+. More than six errors indicates that the corresponding block information word contains six or more non-correctable errors or that the block checkword contains errors. The pilot does not have to be present to decode RDS/RBDS.

**\*Note:** RDS/RBDS is referred to only as RDS throughout the remainder of this document.

## 4.16. Tuning

The tuning frequency is directly programmed using the FM\_TUNE\_FREQ and AM\_TUNE\_FREQ commands. The Si473x-D60 supports channel spacing steps of 10 kHz in FM mode and 1 kHz in AM mode.

## 4.17. Seek

The Si473x-D60 seek functionality is performed completely on-chip and will search up or down the selected frequency band for a valid channel. A valid channel is qualified according to a series of programmable signal indicators and thresholds. The seek function can be made to stop at the band edge and provide an interrupt, or wrap the band and continue seeking until arriving at the original departure frequency. The device sets interrupts with found valid stations or, if the seek results in zero found valid stations, the device indicates failure and again sets an interrupt. Refer to “AN332: Si47xx Programming Guide”.

The Si473x-D60 uses RSSI, SNR, and AFC to qualify stations. Most of these variables have programmable thresholds for modifying the seek function according to customer needs.

RSSI is employed first to screen all possible candidate stations. SNR and AFC are subsequently used in screening the RSSI qualified stations. The more thresholds the system engages, the higher the confidence that any found stations will indeed be valid broadcast stations. The Si473x-D60 defaults set RSSI to a mid-level threshold and add an SNR threshold set to a level delivering acceptable audio performance. This trade-off will eliminate very low RSSI stations while keeping the seek time to acceptable levels. Generally, the time to auto-scan and store valid channels for an entire FM band with all thresholds engaged is very short depending on the band content. Seek is initiated using the FM\_SEEK\_START command. The RSSI, SNR, and AFC threshold settings are adjustable using properties.

## 4.18. Reference Clock

The Si473x-D60 reference clock is programmable, supporting RCLK frequencies listed in Table 10, “Reference Clock and Crystal Characteristics,” on page 16. Refer to Table 2, “DC Characteristics,” on page 6 for switching voltage levels and Table 10 for frequency tolerance information.

An onboard crystal oscillator is available to generate the 32.768 kHz reference when an external crystal and load capacitors are provided. Refer to “2. Typical Application Schematic” on page 18. This mode is enabled using the POWER\_UP command. Refer to “AN332: Si47xx Programming Guide”.

The Si473x-D60 performance may be affected by data activity on the SDIO bus when using the integrated internal oscillator. SDIO activity results from polling the tuner for status or communicating with other devices that share the SDIO bus. If there is SDIO bus activity while the Si473x-D60 is performing the seek/tune function, the crystal oscillator may experience jitter, which may result in mistunes, false stops, and/or lower SNR.

For best seek/tune results, Silicon Laboratories recommends that all SDIO data traffic be suspended during Si473x-D60 seek and tune operations. This is achieved by keeping the bus quiet for all other devices on the bus, and delaying tuner polling until the tune or seek operation is complete. The seek/tune complete (STC) interrupt should be used instead of polling to determine when a seek/tune operation is complete.

## 4.19. Control Interface

A serial port slave interface is provided, which allows an external controller to send commands to the Si473x-D60 and receive responses from the device. The serial port can operate in two bus modes: 2-wire mode and 3-wire mode. The Si473x-D60 selects the bus mode by sampling the state of the GPO1 and GPO2 pins on the rising edge of  $\overline{\text{RST}}$ . The GPO1 pin includes an internal pull-up resistor, which is connected while  $\overline{\text{RST}}$  is low, and the GPO2 pin includes an internal pull-down resistor, which is connected while  $\overline{\text{RST}}$  is low. Therefore, it is only necessary for the user to actively drive pins which differ from these states. See Table 14.

**Table 14. Bus Mode Select on Rising Edge of  $\overline{\text{RST}}$**

Bus Mode	GPO1	GPO2
2-Wire	1	0
3-Wire	0 (must drive)	0

After the rising edge of  $\overline{\text{RST}}$ , the pins GPO1 and GPO2 are used as general purpose output (O) pins, as described in Section “4.20. GPO Outputs”. In any bus mode, commands may only be sent after  $V_D$  and  $V_A$  supplies are applied.

In any bus mode, before sending a command or reading a response, the user must first read the status byte to ensure that the device is ready (CTS bit is high).

### 4.19.1. 2-Wire Control Interface Mode

When selecting 2-wire mode, the user must ensure that SCLK is high during the rising edge of  $\overline{\text{RST}}$ , and stays high until after the first start condition. Also, a start condition must not occur within 300 ns before the rising edge of  $\overline{\text{RST}}$ .

The 2-wire bus mode uses only the SCLK and SDIO pins for signaling. A transaction begins with the START condition, which occurs when SDIO falls while SCLK is high. Next, the user drives an 8-bit control word serially on SDIO, which is captured by the device on rising edges of SCLK. The control word consists of a 7-bit device address, followed by a read/write bit (read = 1, write = 0). The Si473x-D60 acknowledges the control word by driving SDIO low on the next falling edge of SCLK.

Although the Si473x-D60 will respond to only a single device address, this address can be changed with the SEN pin (note that the SEN pin is not used for signaling in 2-wire mode). Refer to “AN332: Si47xx Programming Guide”

For write operations, the user then sends an 8-bit data byte on SDIO, which is captured by the device on rising

edges of SCLK. The Si473x-D60 acknowledges each data byte by driving SDIO low for one cycle, on the next falling edge of SCLK. The user may write up to 8 data bytes in a single 2-wire transaction. The first byte is a command, and the next seven bytes are arguments.

For read operations, after the Si473x-D60 has acknowledged the control byte, it will drive an 8-bit data byte on SDIO, changing the state of SDIO on the falling edge of SCLK. The user acknowledges each data byte by driving SDIO low for one cycle, on the next falling edge of SCLK. If a data byte is not acknowledged, the transaction will end. The user may read up to 16 data bytes in a single 2-wire transaction. These bytes contain the response data from the Si473x-D60.

A 2-wire transaction ends with the STOP condition, which occurs when SDIO rises while SCLK is high.

For details on timing specifications and diagrams, refer to Table 4, “2-Wire Control Interface Characteristics” on page 8; Figure 2, “2-Wire Control Interface Read and Write Timing Parameters,” on page 9, and Figure 3, “2-Wire Control Interface Read and Write Timing Diagram,” on page 9.

### 4.19.2. 3-Wire Control Interface Mode

When selecting 3-wire mode, the user must ensure that a rising edge of SCLK does not occur within 300 ns before the rising edge of  $\overline{\text{RST}}$ .

The 3-wire bus mode uses the SCLK, SDIO, and  $\overline{\text{SEN}}$  pins. A transaction begins when the user drives  $\overline{\text{SEN}}$  low. Next, the user drives a 9-bit control word on SDIO, which is captured by the device on rising edges of SCLK. The control word consists of a 9-bit device address (A7:A5 = 101b), a read/write bit (read = 1, write = 0), and a 5-bit register address (A4:A0).

For write operations, the control word is followed by a 16-bit data word, which is captured by the device on rising edges of SCLK.

For read operations, the control word is followed by a delay of one-half SCLK cycle for bus turn-around. Next, the Si473x-D60 will drive the 16-bit read data word serially on SDIO, changing the state of SDIO on each rising edge of SCLK.

A transaction ends when the user sets  $\overline{\text{SEN}}$  high, then pulses SCLK high and low one final time. SCLK may either stop or continue to toggle while  $\overline{\text{SEN}}$  is high.

In 3-wire mode, commands are sent by first writing each argument to register(s) 0xA1–0xA3, then writing the command word to register 0xA0. A response is retrieved by reading registers 0xA8–0xAF.

For details on timing specifications and diagrams, refer to Table 5, “3-Wire Control Interface Characteristics,” on page 10; Figure 4, “3-Wire Control Interface Write

Timing Parameters,” on page 10, and Figure 5, “3-Wire Control Interface Read Timing Parameters,” on page 10.

## 4.20. GPO Outputs

The Si473x-D60 provides three general-purpose output pins. The GPO pins can be configured to output a constant low, constant high, or high-impedance. The GPO pins can be reconfigured as specialized functions.

## 4.21. Firmware Upgrades

The Si473x-D60 contains on-chip program RAM to accommodate minor changes to the firmware. This allows Silicon Labs to provide future firmware updates to optimize the characteristics of new radio designs and those already deployed in the field.

## 4.22. Reset, Powerup, and Powerdown

Setting the RST pin low will disable analog and digital circuitry, reset the registers to their default settings, and disable the bus. Setting the RST pin high will bring the device out of reset.

The Si473x-D60 contains an on-board non-volatile memory for storing its operational firmware. Proper timing as specified in this data sheet, particularly with respect to keeping RST pin low during any power supply transitions, must be honored to avoid the risk of corrupting the contents of this memory, which can render the device permanently non-functional.

A powerdown mode is available to reduce power consumption when the part is idle. Putting the device in powerdown mode will disable analog and digital circuitry while keeping the bus active.

## 4.23. 2 V Operation (SSOP Only)

The Si473x-D60 is capable of operating down to 2 V as the battery drains in an application. Any power-up or reset is not guaranteed to work below the DC characteristics defined in Table 2. This capability enables a much longer run time in battery operated devices.

## 4.24. Programming with Commands

To ease development time and offer maximum customization, the Si473x-D60 provides a simple yet powerful software interface to program the receiver. The device is programmed using commands, arguments, properties, and responses.

To perform an action, the user writes a command byte and associated arguments, causing the chip to execute the given command. Commands control an action such as powerup the device, shut down the device, or tune to a station. Arguments are specific to a given command and are used to modify the command.

Properties are a special command argument used to modify the default chip operation and are generally configured immediately after powerup. Examples of properties are de-emphasis level, RSSI seek threshold, and soft mute attenuation threshold.

Responses provide the user information and are echoed after a command and associated arguments are issued. All commands provide a 1-byte status update, indicating interrupt and clear-to-send status information.

For a detailed description of the commands and properties for the Si473x-D60, see “AN332: Si47xx Programming Guide.”

## 5. Pin Descriptions

### 5.1. Si473x-D60-GM

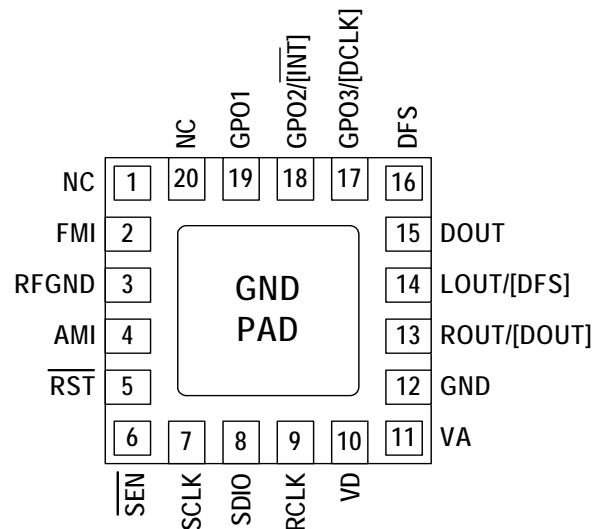

Pin Number(s)	Name	Description
1, 20	NC	No connect. Leave floating.
2	FMI	FM RF inputs. FMI should be connected to the antenna trace.
3	RFGND	RF ground. Connect to ground plane on PCB.
4	AMI	AM RF input. AMI should be connected to the AM antenna.
5	$\overline{\text{RST}}$	Device reset input (active low).
6	$\overline{\text{SEN}}$	Serial enable input (active low).
7	SCLK	Serial clock input.
8	SDIO	Serial data input/output.
9	RCLK	External reference oscillator input.
10	$V_D$	Digital and I/O supply voltage.
11	$V_A$	Analog supply voltage. May be connected directly to battery.
12, GND PAD	GND	Ground. Connect to ground plane on PCB.
13	ROUT/[DOUT]	Right audio line output for analog output mode.
14	LOUT/[DFS]	Left audio line output for analog output mode.
15	DOUT	Digital output data for digital output mode.
16	DFS	Digital frame synchronization input for digital output mode.
17	GPO3/[DCLK]	General purpose output, crystal oscillator, or digital bit synchronous clock input in digital output mode.
18	GPO2/[INT]	General purpose output or interrupt pin.
19	GPO1	General purpose output.

# Si4730/31/34/35-D60

## 5.2. Si473x-D60-GU

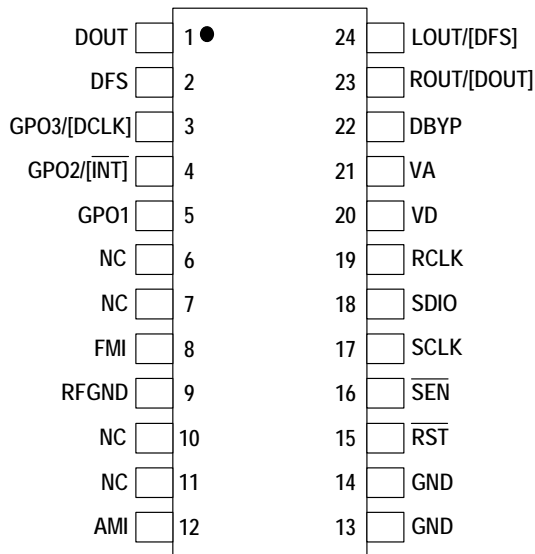

Pin Number(s)	Name	Description
1	DOUT	Digital output data for digital output mode.
2	DFS	Digital frame synchronization input for digital output mode.
3	GPO3/[DCLK]	General purpose output, crystal oscillator, or digital bit synchronous clock input in digital output mode.
4	GPO2/[INT]	General purpose output or interrupt pin.
5	GPO1	General purpose output.
6,7	NC	No connect. Leave floating.
8	FMI	FM RF inputs. FMI should be connected to the antenna trace.
9	RFGND	RF ground. Connect to ground plane on PCB.
10,11	NC	Unused. Tie these pins to GND.
12	AMI	AM/SW/LW RF input.
13,14	GND	Ground. Connect to ground plane on PCB.
15	RST	Device reset input (active low).
16	SEN	Serial enable input (active low).
17	SCLK	Serial clock input.
18	SDIO	Serial data input/output.
19	RCLK	External reference oscillator input.
20	V <sub>D</sub>	Digital and I/O supply voltage.
21	V <sub>A</sub>	Analog supply voltage. May be connected directly to battery.
22	DBYP	Bypass capacitor.
23	ROUT/[DOUT]	Right audio line output in analog output mode.
24	LOUT/[DFS]	Left audio line output in analog output mode.

## 6. Ordering Guide

Part Number <sup>1</sup>	Description	Package Type	Operating Temperature/Voltage
Si4730-D60-GM	AM/FM Broadcast Radio Receiver	QFN Pb-free	-20 to 85 °C 2.7 to 5.5 V
Si4730-D60-GU <sup>2</sup>		SSOP Pb-free	
Si4731-D60-GM	AM/FM Broadcast Radio Receiver with RDS/RBDS	QFN Pb-free	-20 to 85 °C 2.7 to 5.5 V
Si4731-D60-GU <sup>2</sup>		SSOP Pb-free	
Si4734-D60-GM	AM/FM/SW/LW Broadcast Radio Receiver	QFN Pb-free	-20 to 85 °C 2.7 to 5.5 V
Si4734-D60-GU <sup>2</sup>		SSOP Pb-free	
Si4735-D60-GM	AM/FM/SW/LW Broadcast Radio Receiver with RDS/RBDS	QFN Pb-free	-20 to 85 °C 2.7 to 5.5 V
Si4735-D60-GU <sup>2</sup>		SSOP Pb-free	

**Notes:**

1. Add an "(R)" at the end of the device part number to denote tape and reel option.
2. SSOP devices operate down to  $V_A = 2\text{ V}$  at 25 °C.

# Si4730/31/34/35-D60

## 7. Package Outline

### 7.1. Si473x-D60 QFN

Figure 12 illustrates the package details for the Si473x. Table 15 lists the values for the dimensions shown in the illustration.

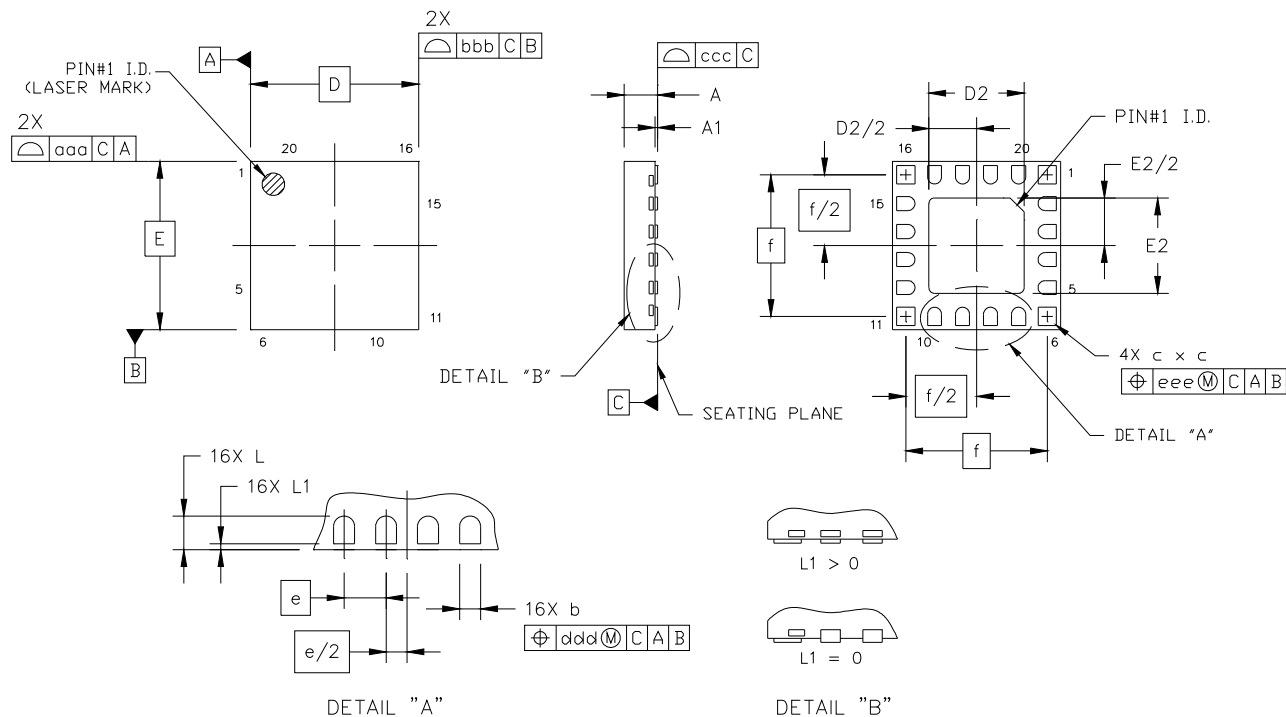

**Figure 12. 20-Pin Quad Flat No-Lead (QFN)**

**Table 15. Package Dimensions**

Symbol	Millimeters			Symbol	Millimeters		
	Min	Nom	Max		Min	Nom	Max
A	0.50	0.55	0.60	f	2.53 BSC		
A1	0.00	0.02	0.05	L	0.35	0.40	0.45
b	0.20	0.25	0.30	L1	0.00	—	0.10
c	0.27	0.32	0.37	aaa	—	—	0.05
D	3.00 BSC			bbb	—	—	0.05
D2	1.65	1.70	1.75	ccc	—	—	0.08
e	0.50 BSC			ddd	—	—	0.10
E	3.00 BSC			eee	—	—	0.10
E2	1.65	1.70	1.75				

**Notes:**

- All dimensions are shown in millimeters (mm) unless otherwise noted.
- Dimensioning and tolerancing per ANSI Y14.5M-1994.

## 7.2. Si473x-D60 SSOP

Figure 13 illustrates the package details for the Si473x. Table 16 lists the values for the dimensions shown in the illustration.

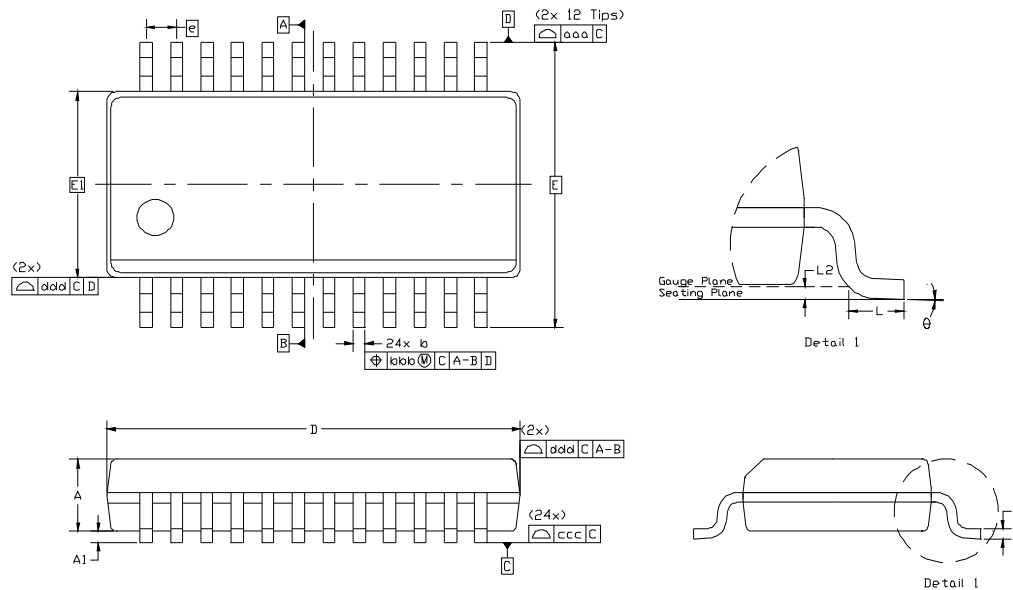

**Figure 13. 24-Pin SSOP**

**Table 16. Package Dimensions**

Dimension	Min	Nom	Max
A	—	—	1.75
A1	0.10	—	0.25
b	0.20	—	0.30
c	0.10	—	0.25
D	8.65 BSC		
E	6.00 BSC		
E1	3.90 BSC		
e	0.635 BSC		
L	0.40	—	1.27
L2	0.25 BSC		
$\theta$	0°	—	8°
aaa	0.20		
bbb	0.18		
ccc	0.10		
ddd	0.10		
<b>Notes:</b>			
1. All dimensions shown are in millimeters (mm) unless otherwise noted.			
2. Dimensioning and Tolerancing per ANSI Y14.5M-1994.			
3. This drawing conforms to the JEDEC Solid State Outline MO-137, Variation AE.			
4. Recommended card reflow profile is per the JEDEC/IPC J-STD-020 specification for Small Body Components.			

## 8. PCB Land Pattern

### 8.1. Si473x-D60 QFN

Figure 14 illustrates the PCB land pattern details for the Si473x-D60-GM QFN. Table 17 lists the values for the dimensions shown in the illustration.

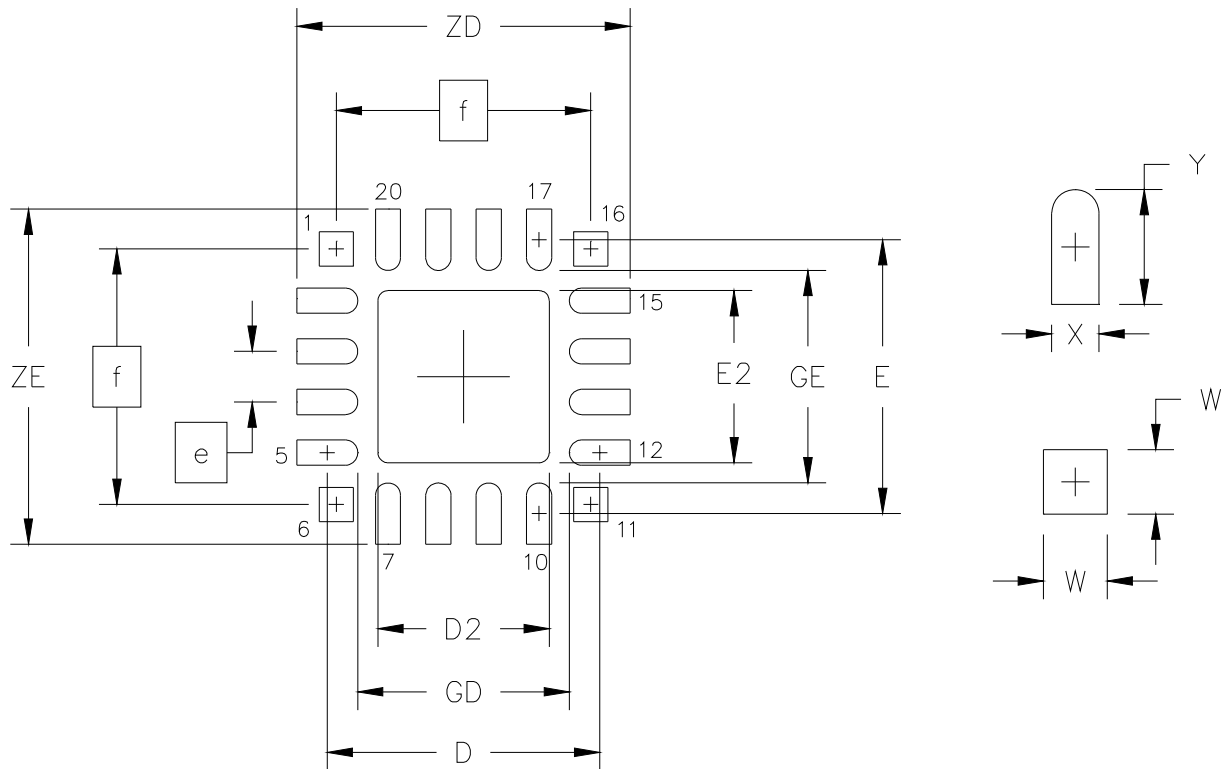

Figure 14. PCB Land Pattern

Table 17. PCB Land Pattern Dimensions

Symbol	Millimeters		Symbol	Millimeters	
	Min	Max		Min	Max
D	2.71 REF		GE	2.10	—
D2	1.60	1.80	W	—	0.34
e	0.50 BSC		X	—	0.28
E	2.71 REF		Y	0.61 REF	
E2	1.60	1.80	ZE	—	3.31
f	2.53 BSC		ZD	—	3.31
GD	2.10	—			

**Notes: General**

- All dimensions shown are in millimeters (mm) unless otherwise noted.
- Dimensioning and Tolerancing is per the ANSI Y14.5M-1994 specification.
- This Land Pattern Design is based on IPC-SM-782 guidelines.
- All dimensions shown are at Maximum Material Condition (MMC). Least Material Condition (LMC) is calculated based on a Fabrication Allowance of 0.05 mm.

**Notes: Solder Mask Design**

- All metal pads are to be non-solder mask defined (NSMD). Clearance between the solder mask and the metal pad is to be 60  $\mu$ m minimum, all the way around the pad.

**Notes: Stencil Design**

- A stainless steel, laser-cut, and electro-polished stencil with trapezoidal walls should be used to assure good solder paste release.
- The stencil thickness should be 0.125 mm (5 mils).
- The ratio of stencil aperture to land pad size should be 1:1 for the perimeter pads.
- A 1.45 x 1.45 mm square aperture should be used for the center pad. This provides approximately 70% solder paste coverage on the pad, which is optimum to assure correct component stand-off.

**Notes: Card Assembly**

- A No-Clean, Type-3 solder paste is recommended.
- The recommended card reflow profile is per the JEDEC/IPC J-STD-020 specification for Small Body Components.

# Si4730/31/34/35-D60

## 8.2. Si473x-D60 SSOP

Figure 15 illustrates the PCB land pattern details for the Si473x-D60-GU SSOP. Table 18 lists the values for the dimensions shown in the illustration.

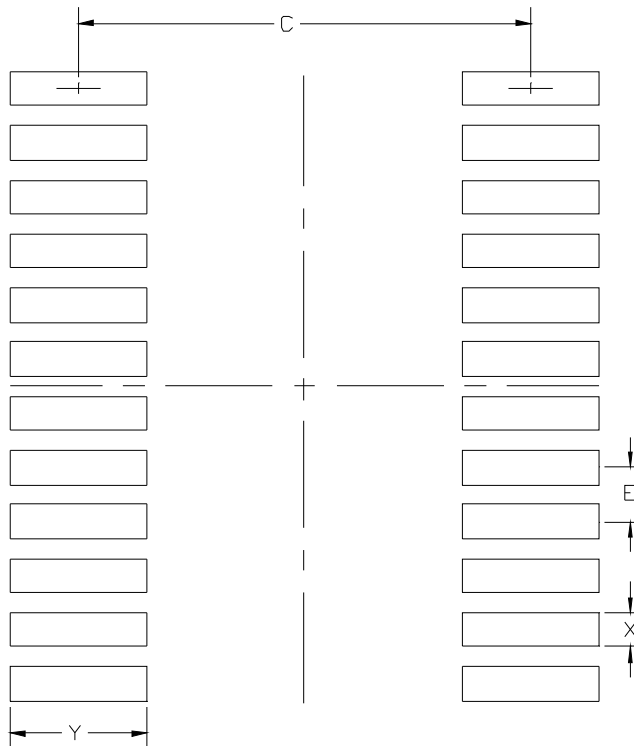

Figure 15. PCB Land Pattern

Table 18. PCB Land Pattern Dimensions

Dimension	Min	Max
C	5.20	5.30
E	0.635 BSC	
X	0.30	0.40
Y1	1.50	1.60
<b>General:</b>		
<ol style="list-style-type: none"> <li>All dimensions shown are in millimeters (mm) unless otherwise noted.</li> <li>This land pattern design is based on the IPC-7351 guidelines.</li> </ol>		
<b>Solder Mask Design:</b>		
<ol style="list-style-type: none"> <li>All metal pads are to be non-solder mask defined (NSMD). Clearance between the solder mask and the metal pad is to be 60 μm minimum, all the way around the pad.</li> </ol>		
<b>Stencil Design:</b>		
<ol style="list-style-type: none"> <li>A stainless steel, laser-cut and electro-polished stencil with trapezoidal walls should be used to assure good solder paste release.</li> <li>The stencil thickness should be 0.125 mm (5 mils).</li> <li>The ratio of stencil aperture to land pad size should be 1:1 for all perimeter pads.</li> </ol>		
<b>Card Assembly:</b>		
<ol style="list-style-type: none"> <li>A No-Clean, Type-3 solder paste is recommended.</li> <li>The recommended card reflow profile is per the JEDEC/IPC J-STD-020 specification for Small Body Components.</li> </ol>		

## 9. Top Markings

### 9.1. Si473x-D60 Top Marking (QFN)

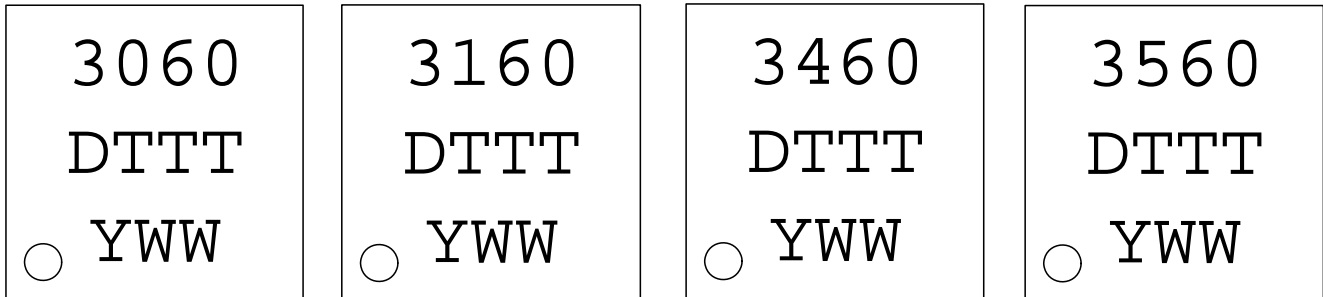

### 9.2. Top Marking Explanation (QFN)

<b>Mark Method:</b>	YAG Laser	
<b>Line 1 Marking:</b>	Part Number	30 = Si4730, 31 = Si4731, 34 = Si4734, 35 = Si4735.
	Firmware Revision	60 = Firmware Revision 6.0.
<b>Line 2 Marking:</b>	Die Revision	D = Revision D Die.
	TTT = Internal Code	Internal tracking code.
<b>Line 3 Marking:</b>	Circle = 0.5 mm Diameter (Bottom-Left Justified)	Pin 1 Identifier.
	Y = Year WW = Workweek	Assigned by the Assembly House. Corresponds to the last significant digit of the year and work week of the mold date.

# Si4730/31/34/35-D60

---

## 9.3. Si473x-D60 Top Marking (SSOP)

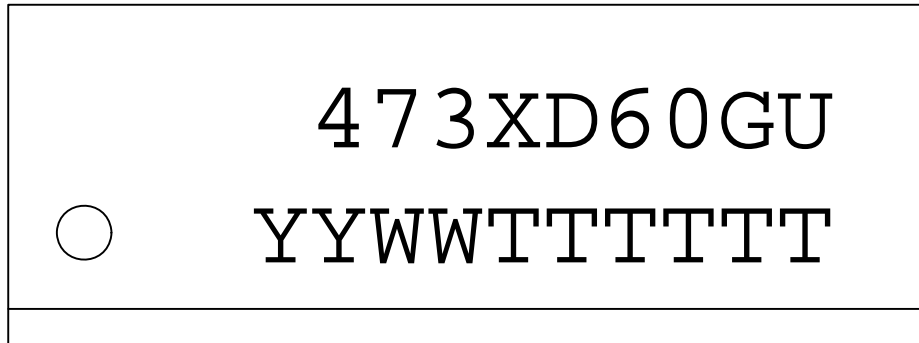

## 9.4. Top Marking Explanation (SSOP)

<b>Mark Method:</b>	YAG Laser	
<b>Line 1 Marking:</b>	Part Number	4730 = Si4730; 4731 = Si4731; 4734 = Si4734; 4735 = Si4735.
	Die Revision	D = Revision D die.
	Firmware Revision	60 = Firmware Revision 6.0.
	Package Type	GU = 24-pin SSOP Pb-free package
<b>Line 2 Marking:</b>	YY = Year WW = Work week TTTTTT = Manufacturing code	Assigned by the Assembly House.

## 10. Additional Reference Resources

Contact your local sales representatives for more information or to obtain copies of the following references:

- EN55020 Compliance Test Certificate
- AN332: Si47xx Programming Guide
- AN383: Si47xx Antenna, Schematic, Layout, and Design Guidelines
- AN388: Si470x/1x/2x/3x/4x Evaluation Board Test Procedure
- Si47xx EVB User's Guide
- Customer Support Site: [www.silabs.com](http://www.silabs.com)  
This site contains all application notes, evaluation board schematics and layouts, and evaluation software. NDA is required for complete access. Please visit the Silicon Labs Technical Support web page: <https://www.silabs.com/support/pages/contacttechnicalsupport.aspx> and register to submit a technical support request.

## DOCUMENT CHANGE LIST

### Revision 1.0 to Revision 1.1

- Updated part number throughout.
- Updated pin assignments on front page.
- Updated block diagram on front page.
- Updated Table 6, “Digital Audio Interface Characteristics,” on page 11.
- Updated Table 10, “Reference Clock and Crystal Characteristics,” on page 16.
- Added Table 11, “Thermal Conditions,” on page 16.
- Updated Section “2. Typical Application Schematic” on page 18.
- Updated Section “4. Functional Description” on page 21.
- Updated Section “5. Pin Descriptions” on page 29.

### Revision 1.1 to Revision 1.2

- Deleted the AUXIN feature.
- Updated Table 3, “Reset Timing Characteristics.”
- Updated Table 11, “Thermal Conditions.”
- Updated Section 4.22, “Reset, Powerup, and Powerdown.”

**NOTES:**

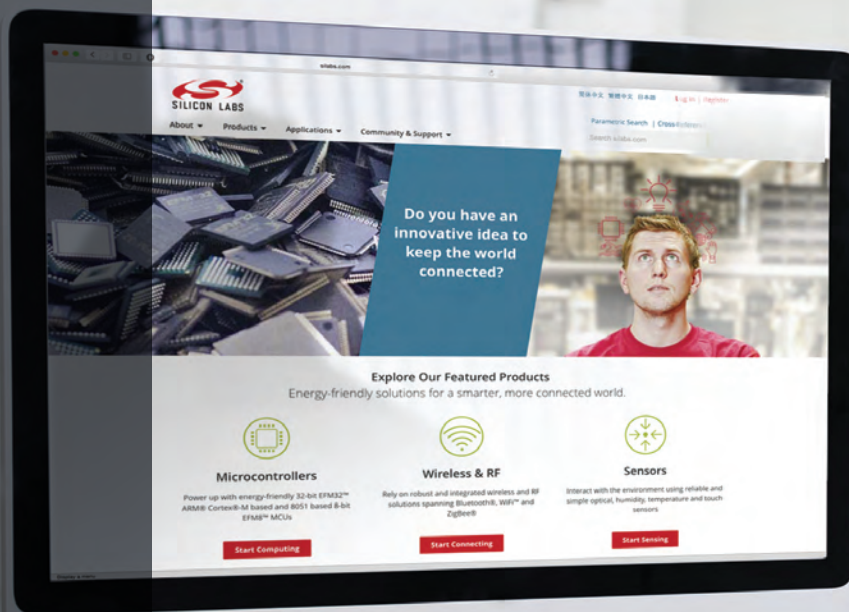

Smart.  
Connected.  
Energy-Friendly



**Products**  
[www.silabs.com/products](http://www.silabs.com/products)

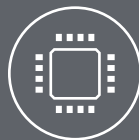

**Quality**  
[www.silabs.com/quality](http://www.silabs.com/quality)



**Support and Community**  
[community.silabs.com](http://community.silabs.com)

#### Disclaimer

Silicon Laboratories intends to provide customers with the latest, accurate, and in-depth documentation of all peripherals and modules available for system and software implementers using or intending to use the Silicon Laboratories products. Characterization data, available modules and peripherals, memory sizes and memory addresses refer to each specific device, and "Typical" parameters provided can and do vary in different applications. Application examples described herein are for illustrative purposes only. Silicon Laboratories reserves the right to make changes without further notice and limitation to product information, specifications, and descriptions herein, and does not give warranties as to the accuracy or completeness of the included information. Silicon Laboratories shall have no liability for the consequences of use of the information supplied herein. This document does not imply or express copyright licenses granted hereunder to design or fabricate any integrated circuits. The products must not be used within any Life Support System without the specific written consent of Silicon Laboratories. A "Life Support System" is any product or system intended to support or sustain life and/or health, which, if it fails, can be reasonably expected to result in significant personal injury or death. Silicon Laboratories products are generally not intended for military applications. Silicon Laboratories products shall under no circumstances be used in weapons of mass destruction including (but not limited to) nuclear, biological or chemical weapons, or missiles capable of delivering such weapons.

#### Trademark Information

Silicon Laboratories Inc., Silicon Laboratories, Silicon Labs, SiLabs and the Silicon Labs logo, CMEMS®, EFM, EFM32, EFR, Energy Micro, Energy Micro logo and combinations thereof, "the world's most energy friendly microcontrollers", Ember®, EZLink®, EZMac®, EZRadio®, EZRadioPRO®, DSPLL®, ISOmodem®, Precision32®, ProSLIC®, SiPHY®, USBXpress® and others are trademarks or registered trademarks of Silicon Laboratories Inc. ARM, CORTEX, Cortex-M3 and THUMB are trademarks or registered trademarks of ARM Holdings. Keil is a registered trademark of ARM Limited. All other products or brand names mentioned herein are trademarks of their respective holders.



Silicon Laboratories Inc.  
400 West Cesar Chavez  
Austin, TX 78701  
USA

<http://www.silabs.com>

## Looking for pricing, stock, or lifecycle information?

Click below to explore more details on WIN SOURCE:

 [View SI4730-D60-GMR](#) on WIN SOURCE

 [Silicon Labs](#) Information

## Optimize Your Supply Chain with WIN SOURCE Solutions

-  Global Sourcing Solution
-  Obsolete Management
-  Cost Control Management
-  Shortage Management
-  Alternative Solution
-  Excess Inventory Management