



**THE DATASHEET OF
SI4700-B15-GMR**





SILICON LABORATORIES

Si4700-B15

BROADCAST FM RADIO TUNER FOR PORTABLE APPLICATIONS

Features

- This data sheet applies to Si4700 Silicon Revision B, Firmware 15 and greater
- Worldwide FM band support (76–108 MHz)
- Digital low-IF receiver
- Frequency synthesizer with integrated VCO
- Seek tuning
- Automatic frequency control (AFC)
- Automatic gain control (AGC)
- Excellent overload immunity
- Signal strength measurement
- Programmable de-emphasis (50/75 μ s)
- Adaptive noise suppression
- Volume control
- Line-level analog output
- 32.768 kHz reference clock
- 2-wire and 3-wire control interface
- 2.7 to 5.5 V supply voltage
- Integrated LDO regulator allows direct connection to battery
- 4x4 mm 24-pin QFN package
 - Pb-free/RoHS compliant

Applications

- Cellular handsets
- MP3 players
- Portable radios
- USB FM radio
- PDAs
- Notebook PCs
- Car audio/RDS
- Media players
- Consumer electronics

Description

The Si4700/01 integrates the complete tuner function from antenna input to stereo audio output for FM broadcast radio reception.

Functional Block Diagram

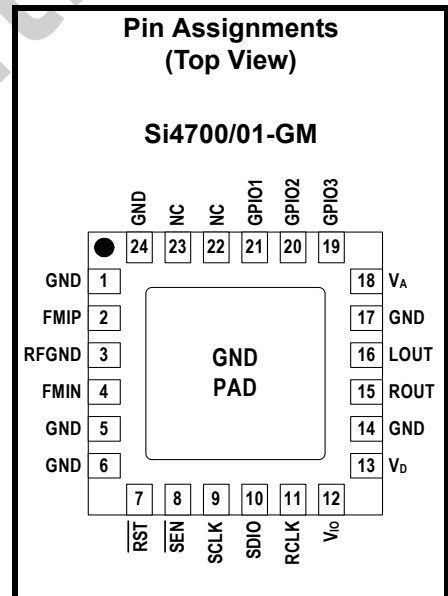
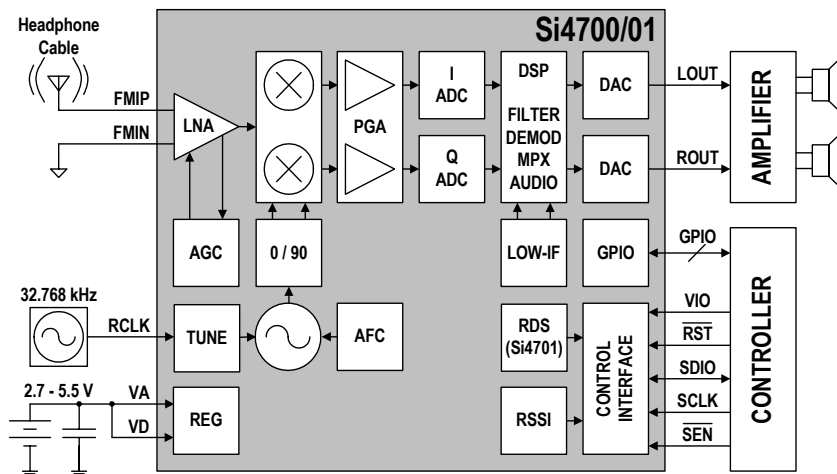

Patents pending

Notes:

1. To ensure proper operation and FM receiver performance, follow the guidelines in "AN231: Si4700/01 Headphone and Antenna Interface." Silicon Laboratories will evaluate schematics and layouts for qualified customers.
2. Place Si4700/01 as close as possible to antenna jack and keep the FMIP trace as short as possible.



Confidential

TABLE OF CONTENTS

<u>Section</u>	<u>Page</u>
1. Electrical Specifications	4
2. Typical Application Schematic	12
3. Bill of Materials	12
4. Functional Description	13
4.1. Overview	13
4.2. FM Receiver	13
4.3. General Purpose I/O Pins	14
4.4. RDS/RBDS Processor and Functionality	14
4.5. Stereo Audio Processing	14
4.6. Tuning	14
4.7. Reference Clock	15
4.8. Control Interface	15
4.9. Reset, Powerup, and Powerdown	16
4.10. Audio Output Summation	17
4.11. Initialization Sequence	18
4.12. Programming Guide	18
5. Register Summary	19
6. Register Descriptions	20
7. Pin Descriptions: Si4700/01-GM	33
8. Ordering Guide	34
9. Package Markings (Top Mark)	35
9.1. Si4700-B15-GM Top Mark	35
9.2. Top Mark Explanation	35
10. Package Outline: Si4700/01-GM	36
11. PCB Land Pattern: Si4700/01-GM	37
12. Additional Reference Resources	38
Document Change List	39
Contact Information	40



Si4700-B15

1. Electrical Specifications

Table 1. Recommended Operating Conditions

Parameter	Symbol	Test Condition	Min	Typ	Max	Unit
Digital Supply Voltage	V_D		2.7	—	5.5	V
Analog Supply Voltage	V_A		2.7	—	5.5	V
Interface Supply Voltage	V_{IO}		1.5	—	3.6	V
Ambient Temperature	T_A		-20	25	85	°C

Note: All minimum and maximum specifications are guaranteed and apply across the recommended operating conditions. Typical values apply at $V_D = V_A = 3.3$ V and 25 °C unless otherwise stated. Parameters are tested in production unless otherwise stated.

Table 2. Absolute Maximum Ratings^{1,2}

Parameter	Symbol	Value	Unit
Digital Supply Voltage	V_D	-0.5 to 5.8	V
Analog Supply Voltage	V_A	-0.5 to 5.8	V
Interface Supply Voltage	V_{IO}	-0.5 to 3.9	V
Input Current ³	I_{IN}	±10	mA
Input Voltage ³	V_{IN}	-0.3 to ($V_{IO} + 0.3$)	V
Operating Temperature	T_{OP}	-40 to 95	°C
Storage Temperature	T_{STG}	-55 to 150	°C
RF Input Level ⁴		0.4	V_{pK}

Notes:

1. Permanent device damage may occur if the above Absolute Maximum Ratings are exceeded. Functional operation should be restricted to the conditions as specified in the operational sections of this data sheet. Exposure beyond recommended operating conditions for extended periods may affect device reliability.
2. The Si4700/01 device is a high-performance RF integrated circuit with an ESD rating of < 2 kV HBM. Handling and assembly of this device should only be done at ESD-protected workstations.
3. For input pins SCLK, SEN, SDIO, RST, RCLK, GPIO1, GPIO2, and GPIO3.
4. At RF input pins.

Table 3. DC Characteristics $(V_D = V_A = 2.7$ to 5.5 V, $V_{IO} = 1.5$ to 3.6 V, $T_A = -20$ to 85 °C)

Parameter	Symbol	Test Condition	Min	Typ	Max	Unit
Analog Supply Current ¹	I_A	ENABLE = 1	—	13.3	14.5	mA
Analog Supply Current ^{1,2,3,4}	I_A	ENABLE = 1 Low SNR level	—	14.1	15.4	mA
Analog Powerdown Current ^{1,5,6}	I_{PDA}	ENABLE = 0	—	2.4	5	μ A
Digital Supply Current ¹	I_D	ENABLE = 1	—	4.3	7.0	mA
Digital Supply Current ^{1,2,3,4}	I_D	ENABLE = 1 Low SNR level	—	4.1	6.5	mA
Digital Powerdown Current ^{1,5,6}	I_{PDD}	ENABLE = 0	—	2.0	5	μ A
Interface Supply Current ¹	I_{IO}	ENABLE = 1	—	420	560	μ A
Interface Powerdown Current ^{1,5,6,7}	I_{IO}	SCLK, RCLK inactive ENABLE = 0	—	1.2	3	μ A
High Level Input Voltage ⁸	V_{IH}		$0.7 \times V_{IO}$	—	$V_{IO} + 0.3$	V
Low Level Input Voltage ⁸	V_{IL}		-0.3	—	$0.3 \times V_{IO}$	V
High Level Input Current ⁸	I_{IH}	$V_{IN} = V_{IO} = 3.6$ V	-10	—	10	μ A
Low Level Input Current ⁸	I_{IL}	$V_{IN} = 0$ V, $V_{IO} = 3.6$ V	-10	—	10	μ A
High Level Output Voltage ⁹	V_{OH}	$I_{OUT} = 500$ μ A	$0.8 \times V_{IO}$	—	—	V
Low Level Output Voltage ⁹	V_{OL}	$I_{OUT} = -500$ μ A	—	—	$0.2 \times V_{IO}$	V

Notes:

1. Refer to Register 02h, "Power Configuration" on page 21 for ENABLE bit description.
2. The LNA is automatically switched to higher current mode for optimum sensitivity in low SNR conditions.
3. Analog and digital supply currents are simultaneously adjusted based on SNR level.
4. Stereo and RDS functionality are disabled at low SNR levels.
5. Specifications are guaranteed by characterization.
6. Refer to Section 4.9. "Reset, Powerup, and Powerdown" on page 16.
7. All GPIO pins are grounded.
8. For input pins SCLK, SEN, SDIO, \overline{RST} , RCLK, GPIO1, GPIO2, and GPIO3.
9. For output pins SDIO, GPIO1, GPIO2, and GPIO3.

Table 4. Reset Timing Characteristics

Parameter	Symbol	Test Condition	Min	Typ	Max	Unit
$\overline{\text{RST}}\downarrow$, GPIO3 Input to $\overline{\text{RST}}\uparrow$ Setup	t_{SRST}	Busmode Select Method 1*	100	—	—	μs
$\overline{\text{SEN}}$, SDIO Input to $\overline{\text{RST}}\uparrow$ Setup	t_{SRST}		30	—	—	ns
$\overline{\text{SEN}}$, SDIO, GPIO3 Input to $\overline{\text{RST}}\uparrow$ Hold	t_{HRST}		30	—	—	ns
GPIO1, GPIO3 Input to $\overline{\text{RST}}\uparrow$ Setup	t_{SRST}	Busmode Select Method 2	30	—	—	ns
GPIO1, GPIO3 Input to $\overline{\text{RST}}\uparrow$ Hold	t_{HRST}		30	—	—	ns

***Note:** In Busmode Select Method 1, GPIO3 may be left high-Z (minimum pullup 10 M Ω), be left floating, or pulled low to be backwards compatible with silicon revision A. If GPIO3 is pulled low then the minimum t_{SRST} for $\overline{\text{RST}}\downarrow$, GPIO3 input to $\overline{\text{RST}}\uparrow$ setup is only 30 ns.

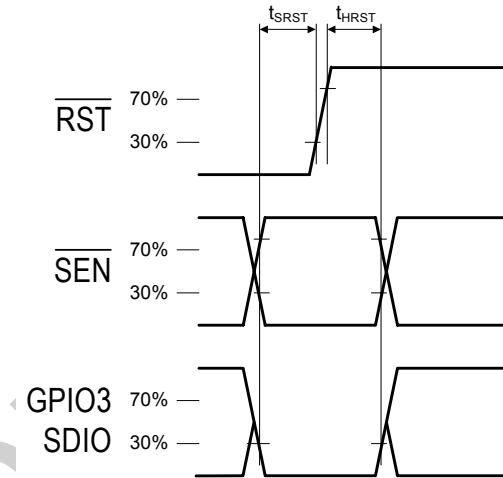

Figure 1. Reset Timing Parameters for Busmode Select Method 1

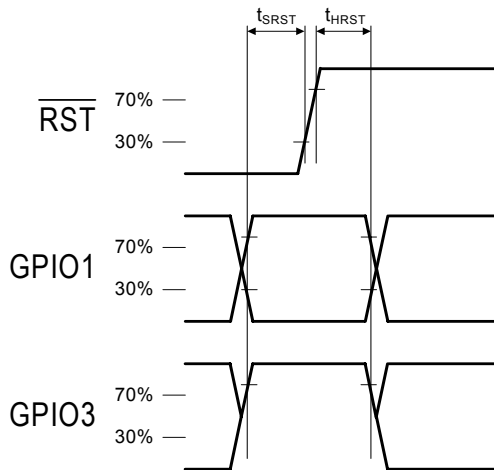
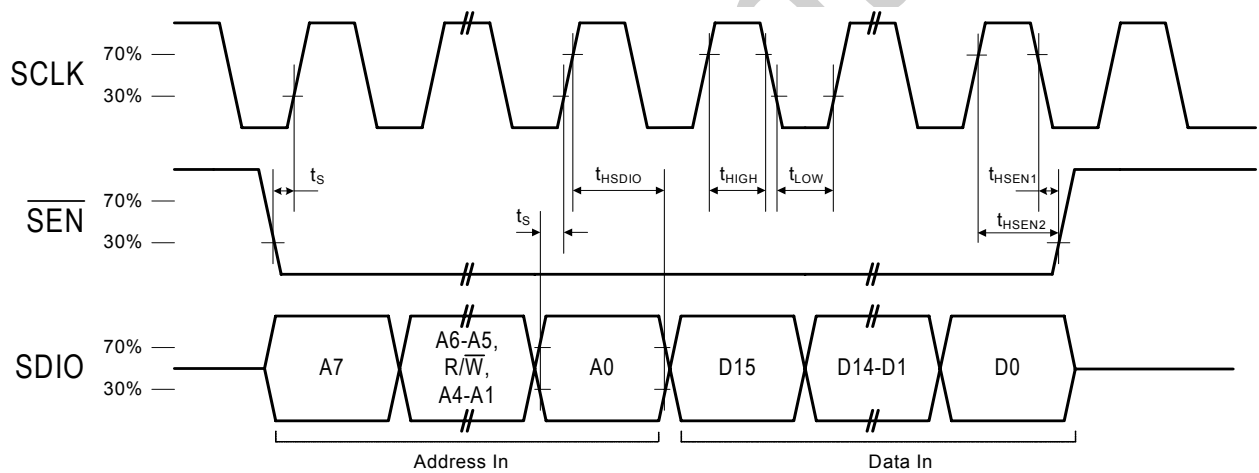
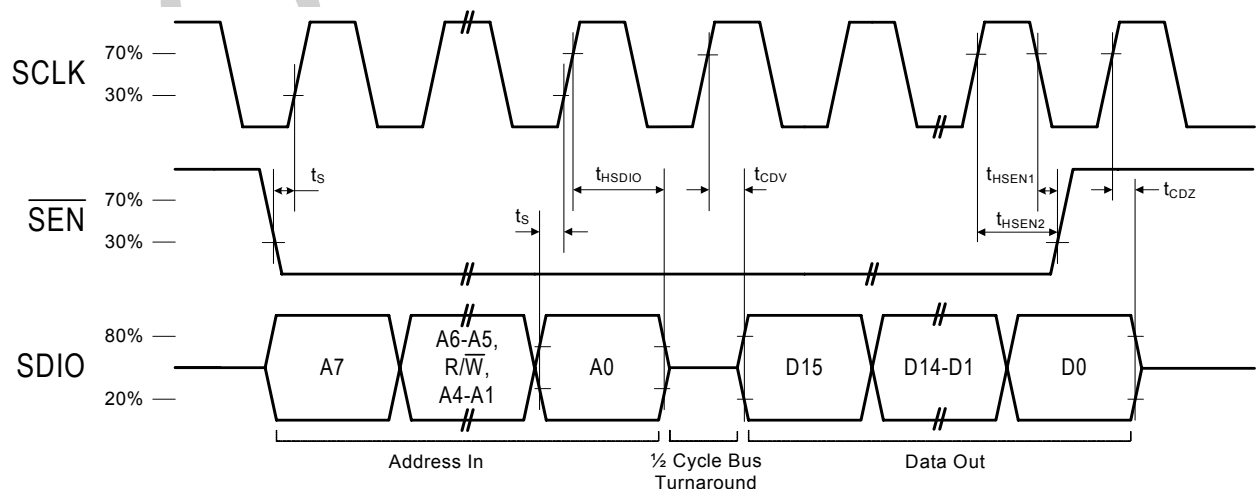

Figure 2. Reset Timing Parameters for Busmode Select Method 2

Table 5. 3-Wire Control Interface Characteristics $(V_D = V_A = 2.7 \text{ to } 5.5 \text{ V}, V_{IO} = 1.5 \text{ to } 3.6 \text{ V}, T_A = -20 \text{ to } 85 \text{ }^\circ\text{C})$

Parameter	Symbol	Test Condition	Min	Typ	Max	Unit
SCLK Frequency	f_{CLK}		0	—	2.5	MHz
SCLK High Time	t_{HIGH}		25	—	—	ns
SCLK Low Time	t_{LOW}		25	—	—	ns
SDIO Input, $\overline{\text{SEN}}$ to SCLK \uparrow Setup	t_s		20	—	—	ns
SDIO Input to SCLK \uparrow Hold	t_{HSDIO}		10	—	—	ns
$\overline{\text{SEN}}$ Input to SCLK \downarrow Hold	t_{HSEN1}		10	—	—	ns
$\overline{\text{SEN}}$ Input to SCLK \uparrow Hold	t_{HSEN2}		10	—	—	ns
SCLK \uparrow to SDIO Output Valid	t_{CDV}	Read	2	—	25	ns
SCLK \uparrow to SDIO Output High Z	t_{CDZ}	Read	2	—	25	ns

**Figure 3. 3-Wire Control Interface Write Timing Parameters****Figure 4. 3-Wire Control Interface Read Timing Parameters**

Si4700-B15

Table 6. 2-Wire Control Interface Characteristics¹

($V_D = V_A = 2.7$ to 5.5 V, $V_{IO} = 1.5$ to 3.6 V, $T_A = -20$ to 85 °C)

Parameter	Symbol	Test Condition	Min	Typ	Max	Unit
SCLK Frequency	f_{SCL}		0	—	400	kHz
SCLK Low Time	t_{LOW}		1.3	—	—	μ s
SCLK High Time	t_{HIGH}		0.6	—	—	μ s
SCLK Input to SDIO \downarrow Setup (START)	$t_{SU:STA}$		0.6	—	—	μ s
SCLK Input to SDIO \downarrow Hold (START)	$t_{HD:STA}$		0.6	—	—	μ s
SDIO Input to SCLK \uparrow Setup	$t_{SU:DAT}$		100	—	—	ns
SDIO Input to SCLK \downarrow Hold ^{2,3}	$t_{HD:DAT}$		0	—	900	ns
SCLK input to SDIO \uparrow Setup (STOP)	$t_{SU:STO}$		0.6	—	—	μ s
STOP to START Time	t_{BUF}		1.3	—	—	μ s
SDIO Output Fall Time	$t_{f:OUT}$		$20 + 01.C_b$	—	250	ns
SDIO Input, SCLK Rise/Fall Time	$t_{f:IN}$ $t_{r:IN}$		$20 + 01.C_b$	—	300	ns
SCLK, SDIO Capacitive Loading	C_b		—	—	50	pF
Input Filter Pulse Suppression	t_{SP}		—	—	50	ns

Notes:

1. When $V_{IO} = 0$ V, SCLK and SDIO are low impedance.
2. As a transmitter, the Si4700/01 delays SDIO by a minimum of 300 ns from the V_{IH} threshold of SCLK to comply with the 0 ns $t_{HD:DAT}$ specification.
3. The maximum $t_{HD:DAT}$ has only to be met when $f_{SCL} = 400$ kHz. At frequencies below 400 kHz, $t_{HD:DAT}$ may be violated so long as all other timing parameters are met.

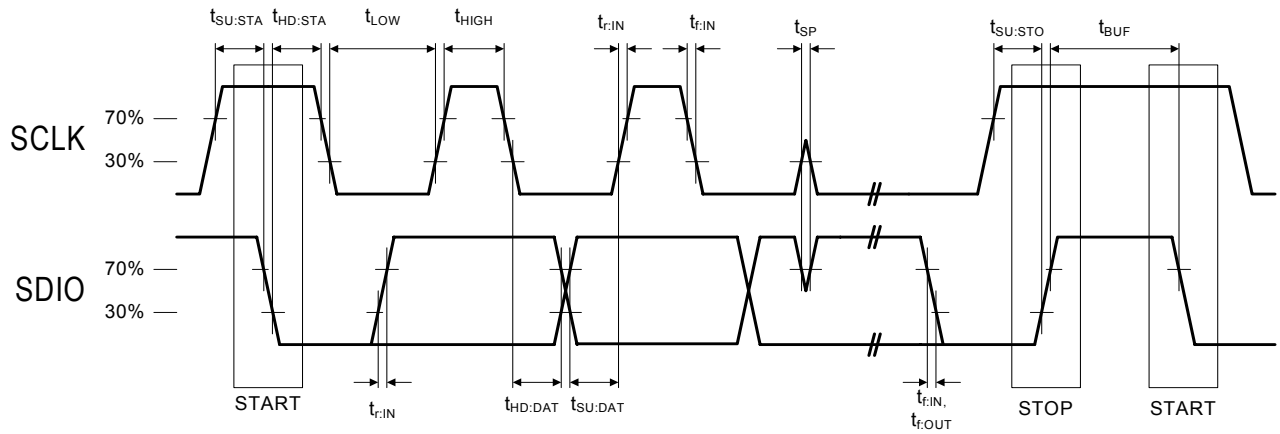

Figure 5. 2-Wire Control Interface Read and Write Timing Parameters

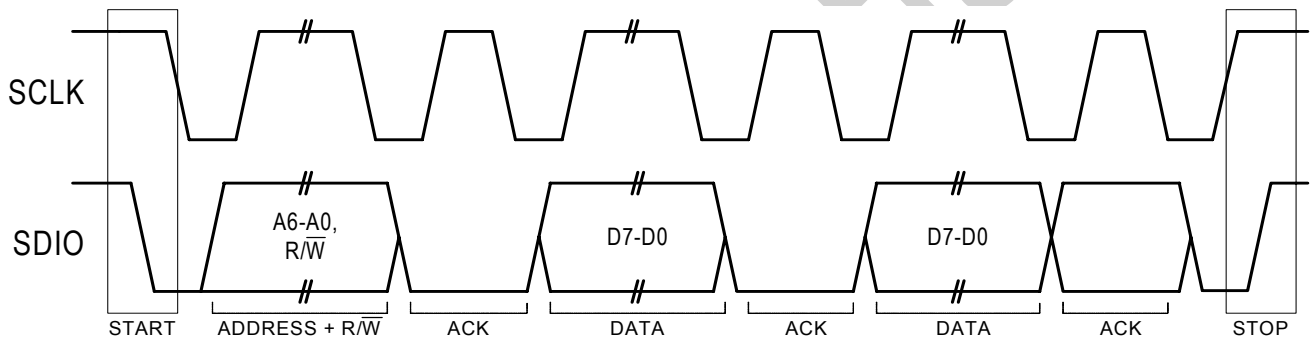

Figure 6. 2-Wire Control Interface Read and Write Timing Diagram

Si4700-B15

Table 7. FM Receiver Characteristics^{1,2}

($V_D = V_A = 2.7$ to 5.5 V, $V_{IO} = 1.5$ to 3.6 V, $T_A = -20$ to 85 °C)

Parameter	Symbol	Test Condition	Min	Typ	Max	Unit
Input Frequency	f_{RF}		76	—	108	MHz
Sensitivity ^{3,4,5,6,7}		(S+N)/N = 26 dB	—	2.5	3.5	μ V EMF
RDS Sensitivity		$\Delta f = 2$ kHz, RDS BLER < 5%	—	15	—	μ V EMF
LNA Input Resistance ^{8,9}			3	4	5	k Ω
LNA Input Capacitance ^{8,9}			4	5	6	pF
Input IP ^{3,9,10}			105	108	—	dB μ V EMF
AM Suppression ^{3,4,5,8,9}		m = 0.3	40	55	—	dB
Adjacent Channel Selectivity		± 200 kHz	35	50	—	dB
Alternate Channel Selectivity		± 400 kHz	60	70	—	dB
Spurious Response Rejection ⁹		In-band	35	—	—	dB
RCLK Frequency			—	32.768	—	kHz
RCLK Frequency Tolerance ¹¹		SPACE[1:0] = 00 or 01	-200	—	200	ppm
		SPACE[1:0] = 10	-50	—	50	
Audio Output Voltage ^{3,4,5,8}			72	80	90	mV _{RMS}
Audio Output L/R Imbalance ^{3,4,8,12}			—	—	1	dB
Audio Band Limits ^{3,4,8,9}		± 1.5 dB	30	—	15k	Hz
Audio Stereo Separation ^{3,8,12}			25	—	—	dB
Audio S/N ^{3,4,5,6,8,9}			58	63	—	dB
Audio THD ^{3,4,8,12}			—	0.1	0.5	%

Notes:

1. Additional testing information is available in Application Note AN234. Volume = maximum for all tests.
2. To ensure proper operation and FM receiver performance, follow the guidelines in "AN231: Si4700/01 Headphone and Antenna Interface." Silicon Laboratories will evaluate schematics and layouts for qualified customers.
3. $F_{MOD} = 1$ kHz, 75 μ s de-emphasis
4. MONO = 1, and L = R unless noted otherwise.
5. $\Delta f = 22.5$ kHz.
6. $B_{AF} = 300$ Hz to 15 kHz, A-weighted.
7. Sensitivity without matching network.
8. Measured at $V_{EMF} = 1$ mV, $f_{RF} = 76$ to 108 MHz.
9. Guaranteed by characterization.
10. $|f_2 - f_1| > 1$ MHz, $f_0 = 2 \times f_1 - f_2$. AGC is disabled by setting AGCD = 1. Refer to "6. Register Descriptions" on page 20.
11. The channel spacing is selected with the SPACE[1:0] bits. Refer to "6. Register Descriptions" on page 20. Seek/Tune timing is guaranteed for 100 and 200 kHz channel spacing.
12. $\Delta f = 75$ kHz.
13. The de-emphasis time constant is selected with the DE bit. Refer to "6. Register Descriptions" on page 20.
14. At LOUT and ROUT pins.



Table 7. FM Receiver Characteristics^{1,2} (Continued) $(V_D = V_A = 2.7$ to 5.5 V, $V_{IO} = 1.5$ to 3.6 V, $T_A = -20$ to 85 °C)

Parameter	Symbol	Test Condition	Min	Typ	Max	Unit
De-emphasis Time Constant ¹³		DE = 0	70	75	80	μs
		DE = 1	45	50	54	μs
Audio Common Mode Voltage ¹⁴		ENABLE = 1	0.7	0.8	0.9	V
Audio Common Mode Voltage		ENABLE = 0 AHIZEN = 1	—	$0.5 \times V_{IO}$	—	V
Audio Output Load Resistance ^{9,14}	R_L	Single-ended	10	—	—	kΩ
Audio Output Load Capacitance ^{9,14}	C_L	Single-ended	—	—	50	pF
Seek/Tune Time ^{9,11}		SPACE[1:0] = 0x, RCLK tolerance = 200 ppm, (x = 0 or 1)	—	—	60	ms/channel
Powerup Time		From powerdown (Write ENABLE bit to 1)	—	—	110	ms
RSSI Offset		Input levels of 8 and 50 dBμV at RF input	-3	—	3	dB

Notes:

1. Additional testing information is available in Application Note AN234. Volume = maximum for all tests.
2. To ensure proper operation and FM receiver performance, follow the guidelines in "AN231: Si4700/01 Headphone and Antenna Interface." Silicon Laboratories will evaluate schematics and layouts for qualified customers.
3. $F_{MOD} = 1$ kHz, 75 μs de-emphasis
4. MONO = 1, and L = R unless noted otherwise.
5. $\Delta f = 22.5$ kHz.
6. $B_{AF} = 300$ Hz to 15 kHz, A-weighted.
7. Sensitivity without matching network.
8. Measured at $V_{EMF} = 1$ mV, $f_{RF} = 76$ to 108 MHz.
9. Guaranteed by characterization.
10. $|f_2 - f_1| > 1$ MHz, $f_0 = 2 \times f_1 - f_2$. AGC is disabled by setting AGCD = 1. Refer to "6. Register Descriptions" on page 20.
11. The channel spacing is selected with the SPACE[1:0] bits. Refer to "6. Register Descriptions" on page 20. Seek/Tune timing is guaranteed for 100 and 200 kHz channel spacing.
12. $\Delta f = 75$ kHz.
13. The de-emphasis time constant is selected with the DE bit. Refer to "6. Register Descriptions" on page 20.
14. At LOUT and ROUT pins.



Si4700-B15

2. Typical Application Schematic

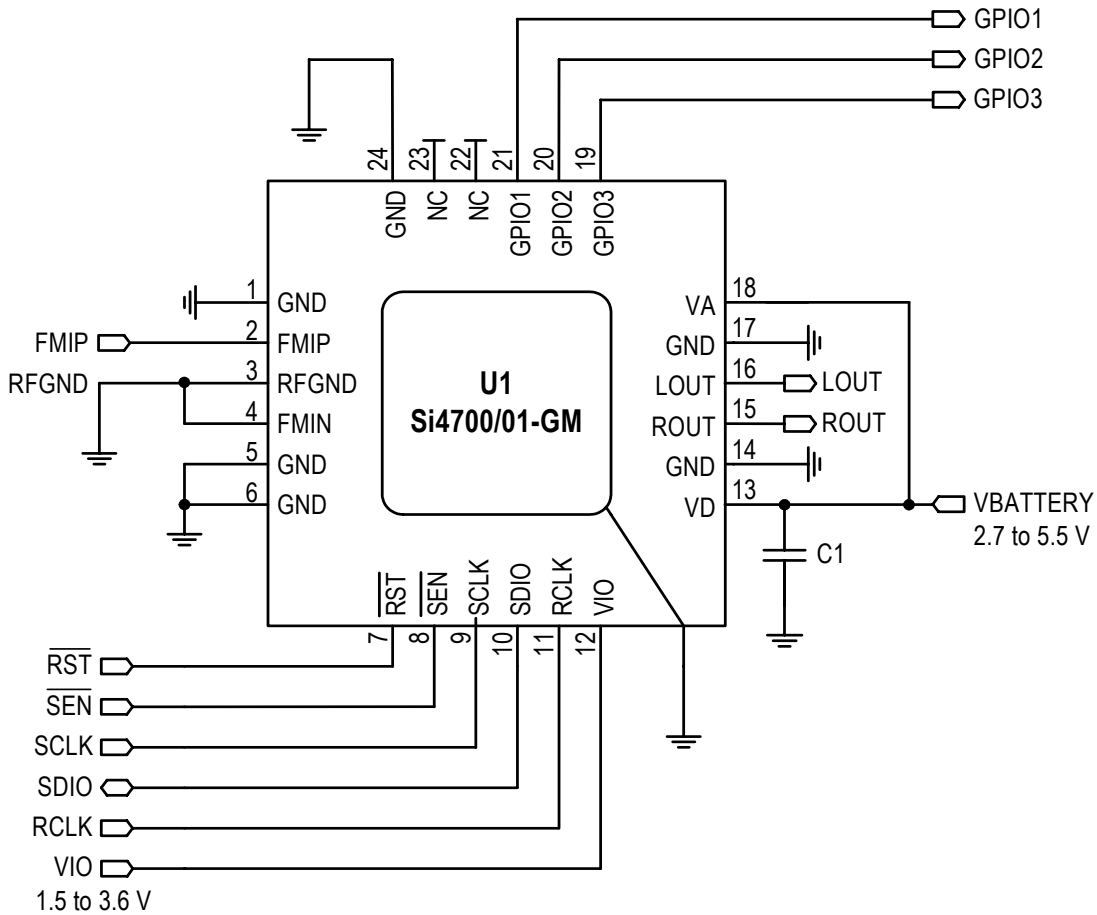

Notes:

1. Place C1 close to VD pin.
2. All grounds connect directly to GND plane on PCB.
3. Pins 22 and 23 are no connects, leave floating.
4. To ensure proper operation and FM receiver performance, follow the guidelines in "AN231: Si4700/01 Headphone and Antenna Interface." Silicon Laboratories will evaluate schematics and layouts for qualified customers.
5. Pin 2 connects to the antenna interface, refer to "AN231: Si4700/01 Headphone and Antenna Interface."
6. RFGND should be locally isolated from GND, refer to "AN231: Si4700/01 Headphone and Antenna Interface."
7. Place Si4700/01 as close as possible to antenna jack and keep the FMIP trace as short as possible.

3. Bill of Materials

Component(s)	Value/Description	Supplier(s)
C1	Supply bypass capacitor, 22 nF, ±20%, Z5U/X7R	Murata
U1	Si4700/01 FM Radio Tuner	Silicon Laboratories

4. Functional Description

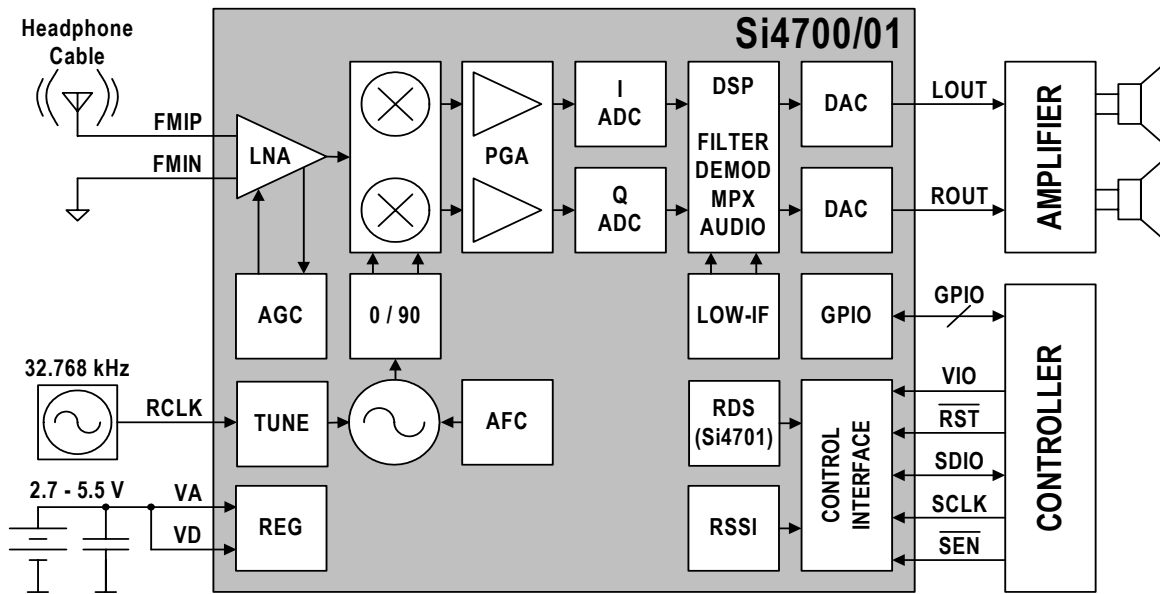

Figure 7. Si4700/01 FM Receiver Block Diagram

4.1. Overview

Leveraging Silicon Laboratories' proven Aero[®] digital low intermediate frequency (low-IF) receiver architecture and frequency synthesizer technology, the Si4700/01 is the industry's first digital FM radio tuner IC implemented using a standard CMOS process. The Si4700/01 delivers superior RF performance and interference rejection by utilizing on-chip digital signal processing, resulting in optimum sound quality with varying reception conditions. Requiring only one external supply bypass capacitor and 20 mm² of board space, the Si4700/01 enables FM radio functionality to be added to a variety of portable devices where board space, performance, low power consumption, and ease of use are essential.

The high level of integration and ease of use simplifies design-in, increases quality, and improves manufacturability. The Si4700/01 uses a streamlined programming model, which further reduces product development time. Power management is also simplified with an integrated regulator allowing direct connection to a 2.7 to 5.5 V battery.

The Si4701 incorporates a digital processor for the European Radio Data System (RDS) and the North American Radio Broadcast Data System (RBDS) including all required symbol decoding, block synchronization, error detection, and error correction functions. Using this feature, the Si4701 enables broadcast data such as station identification and song name to be displayed to the user.

4.2. FM Receiver

The Si4700/01's patented digital low-IF architecture reduces external components and eliminates the need for factory adjustments. The receive (RX) section integrates a low noise amplifier (LNA) supporting the worldwide FM broadcast band (76 to 108 MHz). An automatic gain control (AGC) circuit controls the gain of the LNA to optimize sensitivity and rejection of strong interferers. For testing purposes, the AGC can be disabled with the AGCD bit. Refer to Section 6. "Register Descriptions" on page 20 for additional programming and configuration information.

The Si4700/01 architecture and antenna design increases system performance. To ensure proper performance and operation, designers should refer to the guidelines in "AN231: Si4700/01 Headphone and Antenna Interface". Conformance to these guidelines will help to ensure excellent performance even in weak signal or noisy environments.

An image-reject mixer downconverts the RF signal to low-IF. The quadrature mixer output is amplified, filtered, and digitized with high resolution analog-to-digital converters (ADCs). This advanced architecture achieves superior performance by using digital signal processing (DSP) to perform channel selection, FM demodulation, and stereo audio processing compared to traditional analog architectures.



4.3. General Purpose I/O Pins

The pins GPIO1–3 can serve multiple functions. GPIO1 and GPIO3 can be used to select between 2-wire and 3-wire modes for the control interface as the device is brought out of reset. See Section “4.9. Reset, Powerup, and Powerdown”. After powerup of the device, the GPIO1–3 pins can be used as general purpose inputs/outputs, and the GPIO2–3 pins can be used as interrupt request pins for the seek/tune or RDS ready functions and as a stereo/mono indicator respectively. See register 4, bits [5:0] in Section “6. Register Descriptions” for information on the control of these pins. It is recommended that the GPIO2–3 pins not be used as interrupt request outputs until the powerup time has completed (see Section “4.9. Reset, Powerup, and Powerdown”). The GPIO3 pin has an internal, $1\text{ M}\Omega$, $\pm 15\%$ pull-down resistor that is only active while $\overline{\text{RST}}$ is low. General purpose input/output functionality is available regardless of the state of the V_A and V_D supplies, or the ENABLE and DISABLE bits.

4.4. RDS/RBDS Processor and Functionality

The Si4701 implements an RDS/RBDS* processor for symbol decoding, block synchronization, error detection, and error correction.

4.5. Stereo Audio Processing

The output of the FM demodulator is a stereo multiplexed (MPX) signal. The MPX standard was developed in 1961 and is used worldwide. Today's MPX signal format consists of left + right (L+R) audio, left – right (L–R) audio, a 19 kHz pilot tone, and RDS/RBDS data as shown in Figure 8 below.

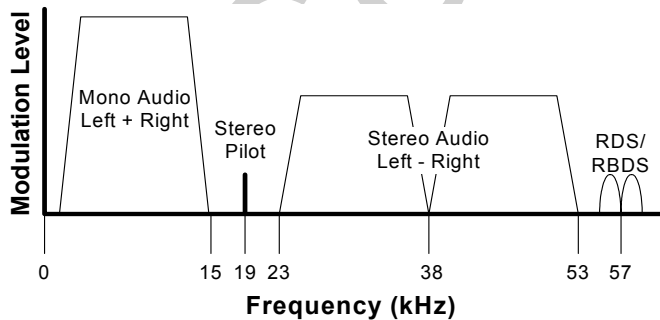

Figure 8. MPX Signal Spectrum

The Si4700/01's integrated stereo decoder automatically decodes the MPX signal. The 0 to 15 kHz (L+R) signal is the mono output of the FM tuner. Stereo is generated from the (L+R), (L–R), and a 19 kHz pilot tone. The pilot tone is used as a reference to recover the (L–R) signal. Separate left and right channels are obtained by adding and subtracting the (L+R) and (L–R)

signals, respectively. The Si4701 uses frequency information from the 19 kHz stereo pilot to recover the 57 kHz RDS/RBDS signal.

Adaptive noise suppression is employed to gradually combine the stereo left and right audio channels to a mono (L+R) audio signal as the signal quality degrades to maintain optimum sound fidelity under varying reception conditions. The signal level range over which the stereo to mono blending occurs can be adjusted by setting the BLNDADJ[1:0] register. Stereo/mono status can be monitored with the ST register bit and mono operation can be forced with the MONO register bit.

Pre-emphasis and de-emphasis is a technique used by FM broadcasters to improve the signal-to-noise ratio of FM receivers by reducing the effects of high frequency interference and noise. When the FM signal is transmitted, a pre-emphasis filter is applied to accentuate the high audio frequencies. All FM receivers incorporate a de-emphasis filter which attenuates high frequencies to restore a flat frequency response. Two time constants, 50 or 75 μs , are used in various regions. The de-emphasis time constant is programmable with the DE bit.

High-fidelity stereo digital-to-analog converters (DACs) drive analog audio signals onto the LOUT and ROUT pins. The audio output may be muted with the DMUTE bit. Volume can be adjusted digitally with the VOLUME[3:0] bits.

The soft mute feature is available to attenuate the audio outputs and minimize audible noise in very weak signal conditions. The soft mute attack and decay rate can be adjusted with the SMUTER[1:0] bits where 00 is the fastest setting. The soft mute attenuation level can be adjusted with the SMUTEA[1:0] bits where 00 is the most attenuated. The soft mute disable (DSMUTE) bit may be set high to disable this feature.

4.6. Tuning

The Si4700/01 uses Silicon Laboratories' patented and proven frequency synthesizer technology including a completely integrated VCO. The frequency synthesizer generates the quadrature local oscillator signal used to downconvert the RF input to a low intermediate frequency. The VCO frequency is locked to the reference clock and adjusted with an automatic frequency control (AFC) servo loop during reception.

The tuning frequency is defined as:

$$\text{Freq (MHz)} = \text{Spacing (kHz)} \times \text{Channel} + \text{Bottom of Band (MHz)}$$

Channel spacing of 50, 100 or 200 kHz is selected with bits SPACE[1:0]. The channel is selected with bits CHAN[9:0]. The bottom of the band is set to 76 MHz or 87.5 MHz with the bits BAND[1:0]. The tuning operation

begins by setting the TUNE bit. After tuning completes, the seek/tune complete (STC) bit will be set and the RSSI level is available by reading bits RSSI[7:0]. The TUNE bit must be set low after the STC bit is set high in order to complete the tune operation and clear the STC bit.

Seek tuning searches up or down for a channel with an RSSI greater than or equal to the seek threshold set with the SEEKTH[7:0] bits. In addition, an optional SNR and/or impulse noise detector may be used to qualify valid stations. The SKSNR[3:0] bits set the SNR threshold required. The SKCNT[3:0] bits set the impulse noise threshold. Using the extra seek qualifiers can reduce false stops and, in combination with lowering the RSSI seek threshold, increase the number of found stations. The SNR and impulse noise detectors are disabled by default.

Two seek modes are available. When the seek mode (SKMODE) bit is low and a seek is initiated, the device seeks through the band, wraps from one band edge to the other, and continues seeking. If the seek operation was unable to find a channel, the seek failure/band limit (SF/BL) bit will be set high and the device will return to the channel selected before the seek operation began. When the SKMODE bit is high and a seek is initiated, the device seeks through the band until the band limit is reached and the SF/BL bit will be set high. A seek operation is initiated by setting the SEEK and SEEKUP bits. After the seek operation completes, the STC bit will be set, and the RSSI level and tuned channel are available by reading bits RSSI[7:0] and bits READCHAN[9:0]. During a seek operation READCHAN[9:0] is also updated and may be read to determine seek progress. The STC bit will be set after the seek operation completes. The channel is valid if the seek operation completes and the SF/BL bit is set low. At other times, such as before a seek operation or after a seek completes and the SF/BL bit is set high, the channel is valid if the AFC Rail (AFCRL) bit is set low and the value of RSSI[7:0] is greater than or equal to SEEKTH[7:0]. Note that if the AFCRL bit is set, the audio output is muted as in the softmute case discussed in Section "4.5. Stereo Audio Processing". The SEEK bit must be set low after the STC bit is set high in order to complete the seek operation and clear the STC and SF/BL bits. The seek operation may be aborted by setting the SEEK bit low at any time.

The device can be configured to generate an interrupt on GPIO2 when a tune or seek operation completes. Setting the seek/tune complete (STCIEN) bit and GPIO2[1:0] = 01 will configure GPIO2 for a 5 ms low interrupt when the STC bit is set by the device.

For additional recommendations on optimizing the seek

function, consult "AN284: Si4700/01 Firmware 15 Seek Adjustability and Settings."

4.7. Reference Clock

The Si4700/01 accepts a 32.768 kHz reference clock to the RCLK pin. The reference clock is required whenever the ENABLE bit is set high. Refer to Table 3, "DC Characteristics," on page 5 for switching voltage levels and Table 7, "FM Receiver Characteristics," on page 10 for frequency tolerance information.

4.8. Control Interface

Two-wire slave-transceiver and three-wire interfaces are provided for the controller IC to read and write the control registers. Refer to "4.9. Reset, Powerup, and Powerdown" for a description of bus mode selection. Registers may be written and read when the V_{IO} supply is applied regardless of the state of the V_D or V_A supplies. RCLK is not required for proper register operation.

4.8.1. 3-Wire Control Interface

For three-wire operation, a transfer begins when the \overline{SEN} pin is set low on a rising SCLK edge. The control word is latched internally on rising SCLK edges and is nine bits in length, comprised of a four bit chip address $A7:A4 = 0110b$, a read/write bit (write = 0 and read = 1), and a four bit register address, $A3:A0$. The ordering of the control word is $A7:A5$, R/W, $A4:A0$. Refer to Section 5. "Register Summary" on page 19 for a list of all registers and their addresses.

For write operations, the serial control word is followed by a 16-bit data word and is latched internally on rising SCLK edges.

For read operations, a bus turn-around of half a cycle is followed by a 16-bit data word shifted out on rising SCLK edges and is clocked into the system controller on falling SCLK edges. The transfer ends on the rising SCLK edge after \overline{SEN} is set high. Note that 26 SCLK cycles are required for a transfer, however, SCLK may run continuously.

For details on timing specifications and diagrams, refer to Table 5, "3-Wire Control Interface Characteristics," on page 7, Figure 3, "3-Wire Control Interface Write Timing Parameters," on page 7, and Figure 4, "3-Wire Control Interface Read Timing Parameters," on page 7.

4.8.2. 2-wire Control Interface

For two-wire operation, a transfer begins with the START condition. The control word is latched internally on rising SCLK edges and is eight bits in length, comprised of a seven bit device address equal to 0010000b and a read/write bit (write = 0 and read = 1). The device acknowledges the address by setting SDIO



low on the next falling SCLK edge.

For write operations, the device acknowledge is followed by an eight bit data word latched internally on rising edges of SCLK. The device always acknowledges the data by setting SDIO low on the next falling SCLK edge. An internal address counter automatically increments to allow continuous data byte writes, starting with the upper byte of register 02h, followed by the lower byte of register 02h, and onward until the lower byte of the last register is reached. The internal address counter then automatically wraps around to the upper byte of register 00h and proceeds from there until continuous writes cease. Data transfer ceases with the STOP command. After every STOP command, the internal address counter is reset.

For read operations, the device acknowledge is followed by an eight bit data word shifted out on falling SCLK edges. An internal address counter automatically increments to allow continuous data byte reads, starting with the upper byte of register 0Ah, followed by the lower byte of register 0Ah, and onward until the lower byte of the last register is reached. The internal address counter then automatically wraps around to the upper byte of register 00h and proceeds from there until continuous reads cease. After each byte of data is read, the controller IC should return an acknowledge if an additional byte of data will be requested. Data transfer ceases with the STOP command. After every STOP command, the internal address counter is reset.

For details on timing specifications and diagrams, refer to Table 6, “2-Wire Control Interface Characteristics¹,” on page 8, Figure 5, “2-Wire Control Interface Read and Write Timing Parameters,” on page 9 and Figure 6, “2-Wire Control Interface Read and Write Timing Diagram,” on page 9.

4.9. Reset, Powerup, and Powerdown

Driving the $\overline{\text{RST}}$ pin low will disable the Si4700/01 and its control bus interface, and reset the registers to their default settings. Driving the $\overline{\text{RST}}$ pin high will bring the device out of reset. As the part is brought out of reset, one of two methods may be used to select between 2-wire and 3-wire control interface operation.

Busmode select method 1, which is compatible with the Si4700/01 revision A, requires the use of the GPIO3, $\overline{\text{SEN}}$, and SDIO pins. The GPIO3 pin should be externally driven low, set to hi-Z or float, and the SDIO pin should be externally driven low on the rising edge of $\overline{\text{RST}}$. GPIO3 has an internal 1 M Ω pulldown resistor. To ensure proper bus mode selection, no less than a 10 M Ω pull-up should be used on the GPIO3 pin. To select 2-wire operation of the control interface, the $\overline{\text{SEN}}$ pin should be externally driven high on the rising edge

of $\overline{\text{RST}}$. To select 3-wire operation of the control interface, the $\overline{\text{SEN}}$ pin should be externally driven low on the rising edge of $\overline{\text{RST}}$. Refer to Table 4, “Reset Timing Characteristics,” on page 6 and Figure 1, “Reset Timing Parameters for Busmode Select Method 1,” on page 6.

Busmode select method 2 only requires the use of the GPIO3 and GPIO1 pins. The GPIO3 pin should be driven high on the rising edge of $\overline{\text{RST}}$. Using this control interface bus selection method, a 100 k Ω or lower pull-up resistor should be used on the GPIO3 pin. To select 2-wire operation of the control interface, the GPIO1 pin should be externally driven high on the rising edge of $\overline{\text{RST}}$. To select 3-wire operation of the control interface, the GPIO1 pin should be externally driven low on the rising edge of $\overline{\text{RST}}$. Refer to Table 4, “Reset Timing Characteristics,” on page 6 and Figure 2, “Reset Timing Parameters for Busmode Select Method 2,” on page 6. Table 8 below summarizes the two bus selection methods.

Table 8. Selecting 2-wire or 3-wire control interface busmode operation¹

Busmode Select Method	$\overline{\text{SEN}}$	SDIO	GPIO1	GPIO3 ²	Bus mode
1	0	0	X	0 ³	3-wire
1	1	0	X	0 ³	2-wire
2	X	X	0	1 ⁴	3-wire
2	X	X	1	1 ⁴	2-wire

Notes:

1. All parameters applied on rising edge of $\overline{\text{RST}}$.
2. GPIO3 is internally pulled down with a 1 M Ω resistor.
3. GPIO3 should be externally driven low, set to high-Z (10 M Ω or greater pull-up) or float.
4. GPIO3 should be externally driven high (100 k Ω or smaller pull-up).

When proper voltages are applied to the Si4700/01, the ENABLE and DISABLE bits in register 02h can be used to select between powerup and powerdown modes. When voltage is first applied to the device, ENABLE = DISABLE = 0. Setting ENABLE = 1 and DISABLE = 0 puts the device in powerup mode. To power down the device, the ENABLE and DISABLE bits should both be written to 1. After being written to 1, both bits will get cleared as part of the internal device powerdown sequence. To put the device back into powerup mode, set ENABLE = 1 and DISABLE = 0 as described above. The ENABLE bit should never be written to a 0.

4.10. Audio Output Summation

The audio outputs LOUT and ROUT may be capacitively summed with another device. Setting the audio high-Z enable (AHIZEN) bit maintains a dc bias of $0.5 \times V_{IO}$ on the LOUT and ROUT pins to prevent the ESD diodes from clamping to the V_{IO} or GND rail in response to the output swing of the other device. The bias point is set with a 160 k Ω resistor to V_{IO} and GND. Register 07h containing the AHIZEN bit must not be written during the powerup sequence and only takes effect when in powerdown and V_{IO} is supplied. In powerup the LOUT and ROUT pins are set to the common mode voltage specified in Table 7, "FM Receiver Characteristics^{1,2}," on page 10, regardless of the state of AHIZEN. Bits 13:0 of register 07h must be preserved as 0x0100 while in powerdown and as 0x3C04 while in powerup.

Confidential



4.11. Initialization Sequence

Refer to Figure 9, "Initialization Sequence," on page 18.

To initialize the device:

1. Supply V_A and V_D .
2. Supply V_{IO} while keeping the \overline{RST} pin low. Note that steps 1 and 2 may be reversed. Power supplies may be sequenced in any order.
3. Provide RCLK. Steps 3 and 4 may be reversed.
4. Select 2-wire or 3-wire control interface bus mode operation as described in Section 4.9. "Reset, Powerup, and Powerdown" on page 16.
5. Set the ENABLE bit high and the DISABLE bit low to powerup the device. Software should wait for the powerup time (as specified by Table 7, "FM Receiver Characteristics^{1,2}," on page 10) before continuing with normal part operation.

To power down the device:

1. (Optional) Set the AHIZEN bit high to maintain a dc bias of $0.5 \times V_{IO}$ volts at the LOOUT and ROOUT pins while in powerdown, but preserve the states of the other bits in Register 07h. Note that in powerup the LOOUT and ROOUT pins are set to the common mode voltage specified in Table 7 on page 10, regardless of the state of AHIZEN.
2. Set the ENABLE bit high and the DISABLE bit high to place the device in powerdown mode. Note that all register states are maintained so long as V_{IO} is supplied and the \overline{RST} pin is high.
3. (Optional) Remove RCLK.
4. Remove V_A and V_D supplies as needed.

To power up the device (after power down):

1. Note that V_{IO} is still supplied in this scenario. If V_{IO} is not supplied, refer to device initialization procedure above.
2. (Optional) Set the AHIZEN bit low to disable the dc bias of $0.5 \times V_{IO}$ volts at the LOOUT and ROOUT pins, but preserve the states of the other bits in Register 07h. Note that in powerup the LOOUT and ROOUT pins are set to the common mode voltage specified in Table 7 on page 10, regardless of the state of AHIZEN.
3. Supply V_A and V_D .
4. Provide RCLK.
5. Set the ENABLE bit high and the DISABLE bit low to powerup the device.

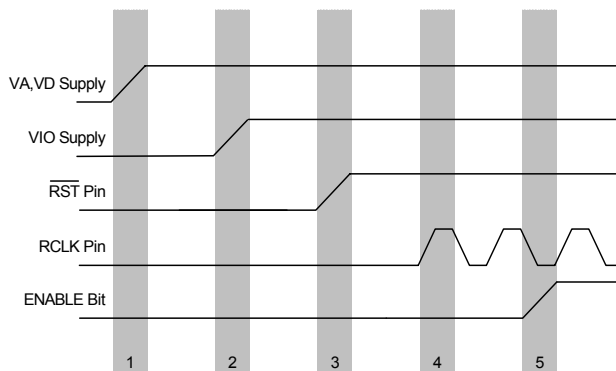

Figure 9. Initialization Sequence

4.12. Programming Guide

Refer to "AN230: Si4700/01 Programming Guide" for control interface programming information.

5. Register Summary

Reg*	Name	D15	D14	D13	D12	D11	D10	D9	D8	D7	D6	D5	D4	D3	D2	D1	D0
00h	DEVICEID	PN[3:0]			MFGID[11:0]												
01h	CHIPID	REV[5:0]			FIRMWARE[8:0]												
02h	POWERCFG	DSMUTE	DMUTE	MONO	0	0	SKMODE	SEEKUP	SEEK	0	DISABLE	0	0	0	0	0	ENABLE
03h	CHANNEL	TUNE	0	0	0	0	CHAN[9:0]										
04h	SYSCONFIG1	0	STCIEN	0	0	DE	AGCD	0	0	BLNDADJ[1:0]	GPIO3[1:0]	GPIO2[1:0]	GPIO1[1:0]				
05h	SYSCONFIG2	SEEKTH[7:0]					SPACE[1:0]										
06h	SYSCONFIG3	SMUTER[1:0]	SMUTEA[1:0]		0	0	0	0	SKSNR[3:0]			SKCNT[3:0]					
07h	TEST1	AHIZEN															
08h	TEST2																
09h	BOOTCONFIG																
0Ah	STATUSRSSI	0	STC	SF/BL	AFCRL	0	0	0	ST	RSSI[7:0]							
0Bh	READCHAN	0	0	0	0	0	READCHAN[9:0]										
0Ch	Reserved	Reserved															
0Dh	Reserved	Reserved															
0Eh	Reserved	Reserved															
0Fh	Reserved	Reserved															

*Note: Any register not listed is reserved and should not be written. Writing to reserved registers may result in unpredictable behavior.

Si4700-B15

6. Register Descriptions

Register 00h. Device ID

Bit	D15	D14	D13	D12	D11	D10	D9	D8	D7	D6	D5	D4	D3	D2	D1	D0
Name	PN[3:0]					MFGID[11:0]										
Type	R					R										

Reset value = 0x1242

Bit	Name	Function
15:12	PN[3:0]	Part Number. 0x01 = Si4700/01
11:0	MFGID[11:0]	Manufacturer ID. 0x242

Register 01h. Chip ID

Bit	D15	D14	D13	D12	D11	D10	D9	D8	D7	D6	D5	D4	D3	D2	D1	D0
Name	REV[5:0]						DEV	FIRMWARE[8:0]								
Type	R						R	R								

Reset value = 0x0400 for Si4700/01 Revision A.

Reset value = 0x0800 for Si4700/01 Revision B.

Bit	Name	Function
15:10	REV[5:0]	Chip Version. 0x01 = Rev A 0x02 = Rev B
9	DEV	Device. 0 before powerup. 0 after powerup = Si4700. 1 after powerup = Si4701.
8:0	FIRMWARE[8:0]	Firmware Version. 0 before powerup. Firmware version after powerup.

Register 02h. Power Configuration

Bit	D15	D14	D13	D12	D11	D10	D9	D8	D7	D6	D5	D4	D3	D2	D1	D0
Name	DSMUTE	DMUTE	MONO	0	0	SKMODE	SEEKUP	SEEK	0	DISABLE	0	0	0	0	0	ENABLE
Type	R/W	R/W	R/W	R/W	R/W	R/W	R/W	R/W	R/W	R/W	R/W	R/W	R/W	R/W	R/W	R/W

Reset value = 0x0000

Bit	Name	Function
15	DSMUTE	Softmute Disable. 0 = Softmute enable (default). 1 = Softmute disable.
14	DMUTE	Mute Disable. 0 = Mute enable (default). 1 = Mute disable.
13	MONO	Mono Select. 0 = Stereo (default). 1 = Force mono.
12:11	Reserved	Reserved. Always write to 0.
10	SKMODE	Seek Mode. 0 = Wrap at the upper or lower band limit and continue seeking (default). 1 = Stop seeking at the upper or lower band limit.
9	SEEKUP	Seek Direction. 0 = Seek down (default). 1 = Seek up.
8	SEEK	Seek. 0 = Disable (default). 1 = Enable. Notes: 1. Seek begins at the current channel, and goes in the direction specified with the SEEKUP bit. Seek operation stops when a channel is qualified as valid according to the seek parameters, the entire band has been searched (SKMODE = 0), or the upper or lower band limit has been reached (SKMODE = 1). 2. The STC bit is set high when the seek operation completes and/or the SF/BL bit is set high if the seek operation was unable to find a channel qualified as valid according to the seek parameters. The STC and SF/BL bits must be set low by setting the SEEK bit low before the next seek or tune may begin. 3. Seek performance for 50 kHz channel spacing varies according to RCLK tolerance. Silicon Laboratories recommends ± 50 ppm RCLK crystal tolerance for 50 kHz seek performance. 4. A seek operation may be aborted by setting SEEK = 0.
7	Reserved	Reserved. Always write to 0.
6	DISABLE	Powerup Disable. Refer to "4.9. Reset, Powerup, and Powerdown". Default = 0.

Si4700-B15

Bit	Name	Function
5:1	Reserved	Reserved. Always write to 0.
0	ENABLE	Powerup Enable. Refer to “4.9. Reset, Powerup, and Powerdown”. Default = 0.

Register 03h. Channel

Bit	D15	D14	D13	D12	D11	D10	D9	D8	D7	D6	D5	D4	D3	D2	D1	D0
Name	TUNE	0	0	0	0	0	CHANNEL[9:0]									
Type	R/W	R/W	R/W	R/W	R/W	R/W	R/W									

Reset value = 0x0000

Bit	Name	Function
15	TUNE	Tune. 0 = Disable (default). 1 = Enable. The tune operation begins when the TUNE bit is set high. The STC bit is set high when the tune operation completes. The STC bit must be set low by setting the TUNE bit low before the next tune or seek may begin.
14:10	Reserved	Reserved. Always write to 0.
9:0	CHAN[9:0]	Channel Select. Channel value for tune operation. If BAND 05h[7:6] = 00, then Freq (MHz) = Spacing (kHz) x Channel + 87.5 MHz. If BAND 05h[7:6] = 01, BAND 05h[7:6] = 10, then Freq (MHz) = Spacing (kHz) x Channel + 76 MHz. CHAN[9:0] is not updated during a seek operation. READCHAN[9:0] provides the current tuned channel and is updated during a seek operation and after a seek or tune operation completes. Channel spacing is set with the bits SPACE 05h[5:4].

Register 04h. System Configuration 1

Bit	D15	D14	D13	D12	D11	D10	D9	D8	D7	D6	D5	D4	D3	D2	D1	D0
Name	0	STCIEN	0	0	DE	AGCD	0	0	BLNDADJ[1:0]	GPIO3[1:0]	GPIO2[1:0]	GPIO1[1:0]				
Type	R/W	R/W	R/W	R/W	R/W	R/W	R/W	R/W	R/W	R/W	R/W	R/W	R/W	R/W	R/W	R/W

Reset value = 0x0000

Bit	Name	Function
15	Reserved	Reserved. Always write to 0.
14	STCIEN	Seek/Tune Complete Interrupt Enable. 0 = Disable Interrupt (default). 1 = Enable Interrupt. Setting STCIEN = 1 and GPIO2[1:0] = 01 will generate a 5 ms low pulse on GPIO2 when the STC 0Ah[14] bit is set.
13:12	Reserved	Reserved. Always write to 0.
11	DE	De-emphasis. 0 = 75 μ s. Used in USA (default). 1 = 50 μ s. Used in Europe, Australia, Japan.
10	AGCD	AGC Disable. 0 = AGC enable (default). 1 = AGC disable.
9:8	Reserved	Reserved. Always write to 0.
6:7	BLNDADJ[1:0]	Stereo/Mono Blend Level Adjustment. Sets the RSSI range for stereo/mono blend. 00 = 31–49 RSSI dB μ V (default). 01 = 37–55 RSSI dB μ V (+6 dB). 10 = 19–37 RSSI dB μ V (–12 dB). 11 = 25–43 RSSI dB μ V (–6 dB). ST bit set for RSSI values greater than low end of range.
5:4	GPIO3[1:0]	General Purpose I/O 3. 00 = High impedance (default). 01 = Mono/Stereo indicator (ST). The GPIO3 will output a logic high when the device is in stereo, otherwise the device will output a logic low for mono. 10 = Low. 11 = High.



Si4700-B15

Bit	Name	Function
3:2	GPIO2[1:0]	General Purpose I/O 2. 00 = High impedance (default). 01 = STC/RDS interrupt. A logic high will be output unless an interrupt occurs as described below. 10 = Low. 11 = High. Setting STCIEN = 1 will generate a 5 ms low pulse on GPIO2 when the STC 0Ah[14] bit is set. Setting RDSIEN = 1 will generate a 5 ms low pulse on GPIO2 when the RDSR 0Ah[15] bit is set.
1:0	GPIO1[1:0]	General Purpose I/O 1. 00 = High impedance (default). 01 = Reserved. 10 = Low. 11 = High.

Register 05h. System Configuration 2

Bit	D15	D14	D13	D12	D11	D10	D9	D8	D7	D6	D5	D4	D3	D2	D1	D0
Name	SEEKTH[7:0]							BAND[1:0]		SPACE[1:0]		VOLUME[3:0]				
Type	R/W							R/W		R/W		R/W				

Reset value = 0x0000

Bit	Name	Function
15:8	SEEKTH[7:0]	<p>RSSI Seek Threshold. 0x00 = min RSSI (default). 0xFF = max RSSI. SEEKTH presents the logarithmic RSSI threshold for the seek operation. The Si4700/01 will not validate channels with RSSI below the SEEKTH value. SEEKTH is one of multiple parameters that can be used to validate channels. For more information, see "AN284: Si4700/01 Firmware 15 Seek Adjustability and Settings."</p>
7:6	BAND[1:0]	<p>Band Select. 00 = 87.5–108 MHz (US/Europe, Default). 01 = 76–108 MHz (Japan wide band). 10 = 76–90 MHz (Japan). 11 = Reserved.</p>
5:4	SPACE[1:0]	<p>Channel Spacing. 00 = 200 kHz (USA, Australia) (default). 01 = 100 kHz (Europe, Japan). 10 = 50 kHz.</p>
3:0	VOLUME[3:0]	<p>Volume. 0000 = mute (default). 0001 = –28 dB FS. : : 1110 = –2 dB FS. 1111 = 0 dB FS. FS = Full Scale. Volume scale is logarithmic.</p>

Si4700-B15

Register 06h. System Configuration 3

Bit	D15	D14	D13	D12	D11	D10	D9	D8	D7	D6	D5	D4	D3	D2	D1	D0
Name	SMUTER[1:0]		SMUTEA[1:0]		0	0	0	0	SKSNR[3:0]				SKCNT[3:0]			
Type	R/W		R/W		R/W	R/W	R/W	R/W	R/W				R/W			

Reset value = 0x0000

Bit	Name	Function
15:14	SMUTER[1:0]	Softmute Attack/Recover Rate. 00 = fastest (default). 01 = fast. 10 = slow. 11 = slowest.
13:12	SMUTEA[1:0]	Softmute Attenuation. 00 = 16 dB (default). 01 = 14 dB. 10 = 12 dB. 11 = 10 dB.
11:8	Reserved	Reserved. Always write to zero.
7:4	SKSNR[3:0]	Seek SNR Threshold. 0000 = disabled (default). 0001 = min (most stops). 1111 = max (fewest stops). Required channel SNR for a valid seek channel.
3:0	SKCNT[3:0]	Seek FM Impulse Detection Threshold. 0000 = disabled (default). 0001 = max (most stops). 1111 = min (fewest stops). Allowable number of FM impulses for a valid seek channel.

Register 07h. Test 1

Bit	D15	D14	D13	D12	D11	D10	D9	D8	D7	D6	D5	D4	D3	D2	D1	D0
Name	0	AHIZEN														
Type	R/W	R/W	R/W	R/W	R/W	R/W	R/W	R/W	R/W	R/W	R/W	R/W	R/W	R/W	R/W	R/W

Reset value = 0x0100

Bit	Name	Function
15	Reserved	Reserved. Always write to zero.
14	AHIZEN	Audio High-Z Enable. 0 = Disable (default). 1 = Enable. Setting AHIZEN maintains a dc bias of $0.5 \times V_{IO}$ on the LOUT and ROUT pins to prevent the ESD diodes from clamping to the V_{IO} or GND rail in response to the output swing of another device. Register 07h containing the AHIZEN bit must not be written during the powerup sequence and high-Z only takes effect when in powerdown and V_{IO} is supplied. Bits 13:0 of register 07h must be preserved as 0x0100 while in powerdown and as 0x3C04 while in powerup.
13:0	Reserved	Reserved. If written, these bits should be read first and then written with their pre-existing values. Do not write during powerup.

Si4700-B15

Register 08h. Test 2

Bit	D15	D14	D13	D12	D11	D10	D9	D8	D7	D6	D5	D4	D3	D2	D1	D0
Name																
Type	R/W	R/W	R/W	R/W	R/W	R/W	R/W	R/W	R/W	R/W	R/W	R/W	R/W	R/W	R/W	R/W

Reset value = 0x0000

Bit	Name	Function
15:0	Reserved	Reserved. If written, these bits should be read first and then written with their pre-existing values. Do not write during powerup.

Register 09h. Boot Configuration

Bit	D15	D14	D13	D12	D11	D10	D9	D8	D7	D6	D5	D4	D3	D2	D1	D0
Name																
Type	R/W	R/W	R/W	R/W	R/W	R/W	R/W	R/W	R/W	R/W	R/W	R/W	R/W	R/W	R/W	R/W

Reset value = 0x0000

Bit	Name	Function
15:0	Reserved	Reserved. If written, these bits should be read first and then written with their pre-existing values. Do not write during powerup.

Register 0Ah. Status RSSI

Bit	D15	D14	D13	D12	D11	D10	D9	D8	D7	D6	D5	D4	D3	D2	D1	D0
Name	0	STC	SF/BL	AFCRL	0	0	0	ST	RSSI[7:0]							
Type	R	R	R	R	R	R	R	R	R							

Reset value = 0x0000

Bit	Name	Function
15	Reserved	Reserved. Always write to zero.
14	STC	Seek/Tune Complete. 0 = Not complete (default). 1 = Complete. The seek/tune complete flag is set when the seek or tune operation completes. Setting the SEEK 02h[8] or TUNE 03h[15] bit low will clear STC.
13	SF/BL	Seek Fail/Band Limit. 0 = Seek successful. 1 = Seek failure/Band limit reached. The SF/BL flag is set high when SKMODE 02h[10] = 0 and the seek operation fails to find a channel qualified as valid according to the seek parameters. The SF/BL flag is set high when SKMODE 02h[10] = 1 and the upper or lower band limit has been reached. The SEEK 02h[8] bit must be set low to clear SF/BL.
12	AFCRL	AFC Rail. 0 = AFC not railed. 1 = AFC railed, indicating an invalid channel. Audio output is softmuted when set. AFCRL is updated after a tune or seek operation completes and indicates a valid or invalid channel. During normal operation, AFCRL is updated to reflect changing RF environments.
11:9	Reserved	Reserved. Always write to zero.
8	ST	Stereo Indicator. 0 = Mono. 1 = Stereo. Stereo indication is also available on GPIO3 by setting GPIO3 04h[5:4] = 01.
7:0	RSSI[7:0]	RSSI (Received Signal Strength Indicator). RSSI is measured units of dB μ V in 1 dB increments with a maximum of approximately 75 dB μ V. 0x00 = Minimum signal strength. 0xFF = Maximum signal strength. RSSI will not report RF levels above 75 dB μ V.

Si4700-B15

Register 0Bh. Read Channel

Bit	D15	D14	D13	D12	D11	D10	D9	D8	D7	D6	D5	D4	D3	D2	D1	D0
Name	0	0	0	0	0	0	READCHAN[9:0]									
Type	R	R	R	R	R	R	R									

Reset value = 0x0000

Bit	Name	Function
15:10	Reserved	Reserved. Always write to zero.
9:0	READCHAN[9:0]	Read Channel. If BAND 05h[7:6] = 00, then Freq (MHz) = Spacing (kHz) x Channel + 87.5 MHz. If BAND 05h[7:6] = 01, BAND 05h[7:6] = 10, then Freq (MHz) = Spacing (kHz) x Channel + 76 MHz. READCHAN[9:0] provides the current tuned channel and is updated during a seek operation and after a seek or tune operation completes. Spacing and channel are set with the bits SPACE 05h[5:4] and CHAN 03h[9:0].

Confidential

Register 0Ch. Reserved

Bit	D15	D14	D13	D12	D11	D10	D9	D8	D7	D6	D5	D4	D3	D2	D1	D0
Name	Reserved															
Type	R															

Reset value = 0x0000

Bit	Name	Function
15:0	Reserved	

Register 0Dh. Reserved

Bit	D15	D14	D13	D12	D11	D10	D9	D8	D7	D6	D5	D4	D3	D2	D1	D0
Name	Reserved															
Type	R															

Reset value = 0x0000

Bit	Name	Function
15:0	Reserved	

Si4700-B15

Register 0Eh. Reserved

Bit	D15	D14	D13	D12	D11	D10	D9	D8	D7	D6	D5	D4	D3	D2	D1	D0
Name	Reserved															
Type	R															

Reset value = 0x0000

Bit	Name	Function
15:0	Reserved	

Register 0Fh. Reserved

Bit	D15	D14	D13	D12	D11	D10	D9	D8	D7	D6	D5	D4	D3	D2	D1	D0
Name	Reserved															
Type	R															

Reset value = 0x0000

Bit	Name	Function
15:0	Reserved	

7. Pin Descriptions: Si4700/01-GM

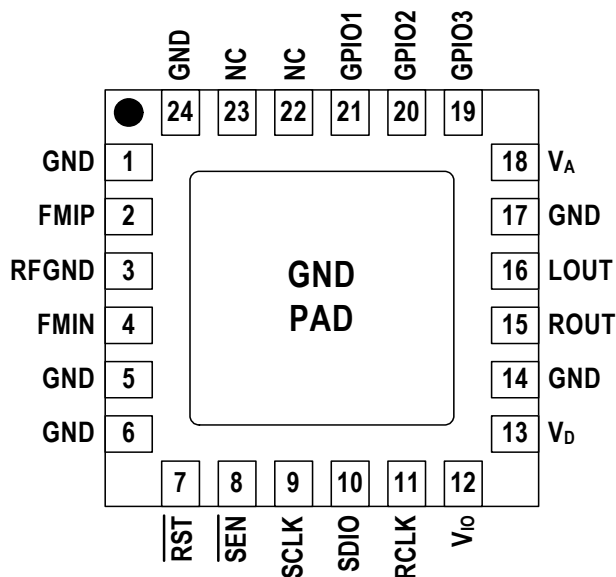

Top View

Pin Number(s)	Name	Description
1, 5, 6, 14, 17, 24, GND PAD	GND	Ground. Connect to ground plane on PCB.
2, 4	FMIP, FMIN	FM RF inputs. For single-ended input, FMIN should be connected to RFGND. FMIP should be connected to the antenna trace.
3	RFGND	RF ground. Connect to ground plane on PCB.
7	$\overline{\text{RST}}$	Device reset (active low) input.
8	$\overline{\text{SEN}}$	Serial enable input (active low).
9	SCLK	Serial clock input.
10	SDIO	Serial data input/output.
11	RCLK	External reference oscillator input.
12	V_{IO}	I/O supply voltage.
13	V_{D}	Digital supply voltage. May be connected directly to battery.
15	ROUT	Right audio output.
16	LOUT	Left audio output.
18	V_{A}	Analog supply voltage. May be connected directly to battery.
19–21	GPIO3, GPIO2, GPIO1	General purpose input/output.
22, 23	NC	No Connect. Leave floating.

Si4700-B15

8. Ordering Guide

Part Number*	Description	Package Type	Operating Temperature
Si4700-B15-GM	Portable broadcast FM stereo radio tuner Silicon revision B, Firmware Revision 15	QFN Pb-free	-20 to 85 °C

*Note: Add an "(R)" at the end of the device part number to denote tape and reel option; 2500 quantity per reel.

Confidential

9. Package Markings (Top Mark)

9.1. Si4700-B15-GM Top Mark



Figure 10. Si4700-B15-GM Top Mark

9.2. Top Mark Explanation

Mark Method:	YAG Laser	
Font Size:	1.5 point (0.53 mm) Right Justified	
Line 1 Marking:	Part Number Die Revision Firmware Revision	4700 B 15
Line 2 Marking:	YY = Year WW = Workweek	Assigned by the Assembly House. Corresponds to the year and workweek of the mold date.
	R = Die Revision F = Wafer Fab	First Two Characters of the Manufacturing Code from the assembly lot release form reflect die revision and wafer fab.
Line 3 Marking:	Circle = 0.5 mm Diameter (Bottom-Left Justified)	Pin 1 Identifier
	A = Assembly House I = Internal Code	Last Two Characters of the Manufacturing Code from the assembly lot release form reflect assembly house and an internal tracking code.
	XX = Serial Lot Number	Assigned by the Assembly House. A <u>unique</u> two character alphanumeric code must be assigned to <u>each</u> lot released during a given workweek. This code is reset at the start of each workweek.

Si4700-B15

10. Package Outline: Si4700/01-GM

Figure 11 illustrates the package details for the Si4700/01-GM. Table 9 lists the values for the dimensions shown in the illustration.

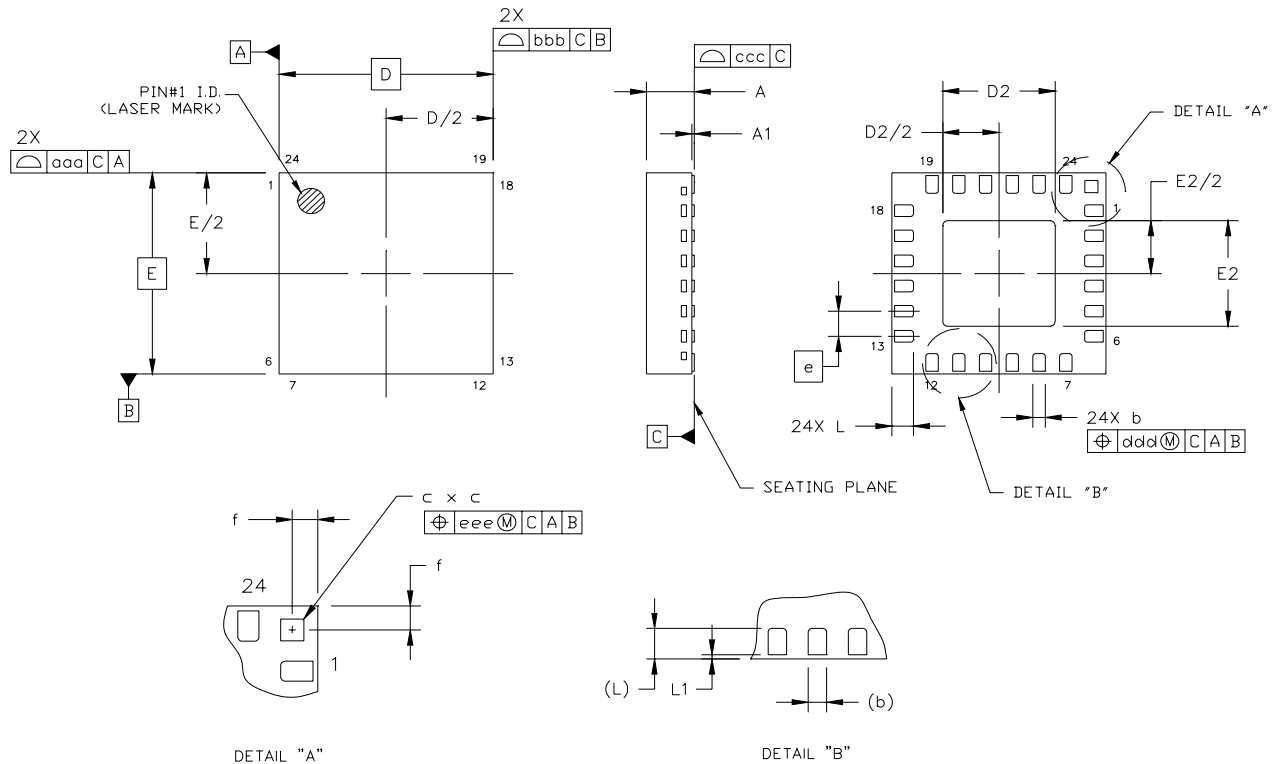

Figure 11. 24-Pin Quad Flat No-Lead (QFN)

Table 9. Package Dimensions

Symbol	Millimeters		
	Min	Nom	Max
A	0.80	0.85	0.90
A1	0.00	0.02	0.05
b	0.18	0.25	0.30
c	0.19	0.24	0.29
D	4.00 BSC		
D2	2.00	2.10	2.20
e	0.50 BSC		
f	0.27 BSC		
E	4.00 BSC		

Symbol	Millimeters		
	Min	Nom	Max
E2	2.00	2.10	2.20
L	0.30	0.40	0.50
L1	0.03	0.05	0.08
aaa	—	—	0.10
bbb	—	—	0.10
ccc	—	—	0.08
ddd	—	—	0.10
eee	—	—	0.10

Notes:

1. All dimensions are shown in millimeters unless otherwise noted.
2. Dimensioning and tolerancing per ANSI Y14.5M-1994.
3. This drawing conforms to the JECEC Solid State Outline MO-220, Variation VGGD-8.
4. Recommended card reflow profile is per the JEDEC/IPC J-STD-020C specification for Small Body Components.
5. Lead-free/RoHS compliant.

11. PCB Land Pattern: Si4700/01-GM

Figure 12 illustrates the package details for the Si4700/01-GM. Table 10 lists the values for the dimensions shown in the illustration.

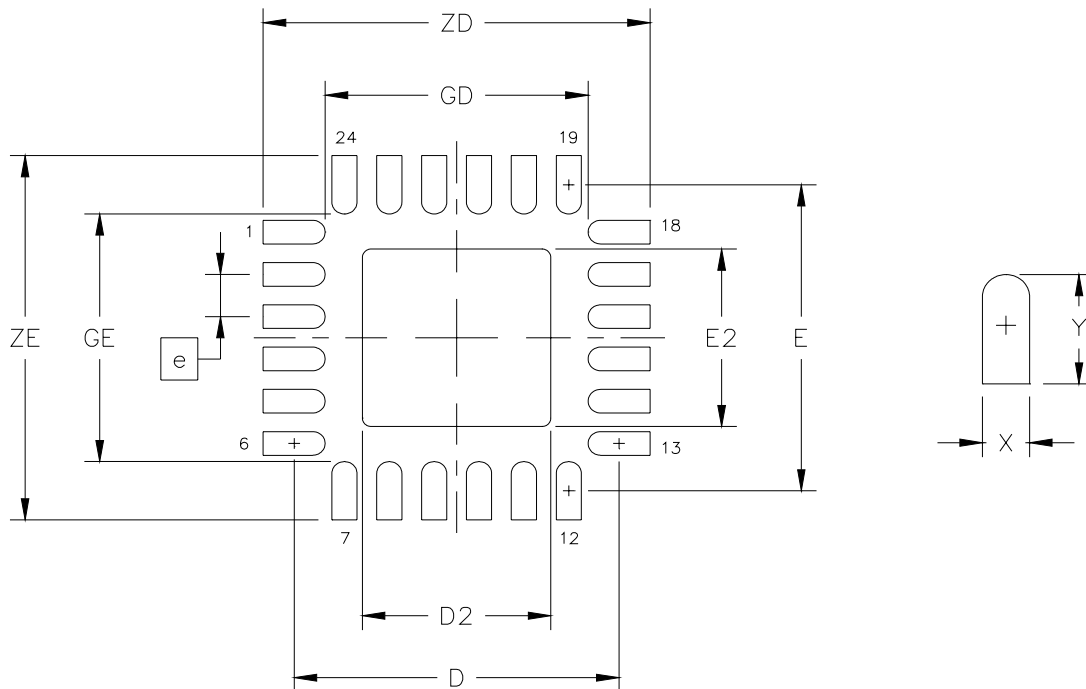

Figure 12. PCB Land Pattern

Table 10. Dimensions for PCB Land Pattern

Dimension	Min	Max
e	0.50 BSC	
E	3.62 REF	
D	3.62 REF	
E2	2.00	2.20
D2	2.00	2.20
GE	2.93	—
GD	2.93	—
X	—	0.28
Y	0.69 REF	
ZE	—	4.31
ZD	—	4.31

12. Additional Reference Resources

- AN230: Si4700/01/02/03 Programming Guide
- AN231: Si4700/01 Headphone and Antenna Interface
- Si4700/01/02/03 EVB User's Guide
- AN234: Si4700/01/02/03 Evaluation Board Test Procedure
- AN235: Si4700/01/02/03 Evaluation Board Quick Start Guide
- AN281: Si4700/01/02/03 Firmware Change List
- AN284: Si4700/01/02/03 Seek Adjustability and Settings
- AN299: Si4702/03 External 32.768 kHz Crystal Oscillator
- Errata: Si4700/01-B15 Internal Crystal Oscillator Errata
- Si4700/01/02/03 Customer Support Site: <http://www.mysilabs.com>

This site contains all application notes, evaluation board schematics and layouts, and evaluation software. NDA is required for access. To request access, register at <http://www.mysilabs.com> and send user's first and last name, company, NDA reference number, and mysilabs user name to fminfo@silabs.com. Silicon Labs recommends an all lower case user name.

Confidential

DOCUMENT CHANGE LIST

Revision 0.87 to Revision 0.9

- Updated Table 3, "DC Characteristics," on page 5.
- Updated Table 4, "Reset Timing Characteristics," on page 6.
- Updated Table 7, "FM Receiver Characteristics^{1,2}," on page 10.
- Updated Sections 4.1. "Overview" on page 13 and 4.2. "FM Receiver" on page 13, 4.3. "General Purpose I/O Pins" on page 14.
- Updated Section 4.6. "Tuning" on page 14, added reference to AN284: Si4700/01 Firmware 15 Seek Adjustability and Settings.
- In Section 4.8. "Control Interface" on page 15, updated descriptions of 2-wire and 3-wire control bus reading and writing.
- In Section 4.9. "Reset, Powerup, and Powerdown" on page 16 updated descriptions of 2-wire and 3-wire control bus selection.
- Added Table 8, "Selecting 2-wire or 3-wire control interface busmode operation¹," on page 16.
- Added XOSCEN and AHIZEN bits to Section 5. "Register Summary" on page 19.
- Updated and reformatted Section 6. "Register Descriptions" on page 20.

Revision 0.9 to Revision 0.91

- Updated Table 5, "3-Wire Control Interface Characteristics," on page 7 with additional timing parameter for t_{HSEN2} .
- Updated Table 7. "FM Receiver Characteristics" on page 10.
- Updated various texts in "4. Functional Description".
- Updated Table 8, "Selecting 2-wire or 3-wire control interface busmode operation¹," on page 16 to show conditional on rising edge of \overline{RST} .
- Updated 6. "Register Descriptions" on page 20.
- Added Blend level adjustments.
- Added Volume scale steps.

Revision 0.91 to Revision 1.0

- Updated Table 3, "DC Characteristics," on page 5.
- Updated Table 7, "FM Receiver Characteristics^{1,2}," on page 10.
- Removed internal oscillator text, figures, and descriptions.
- Added supporting detail to Section 6. "Register Descriptions" on page 20.
- Added Section 9. "Package Markings (Top Mark)" on page 35.
- Added additional reference resources to the list in Section 12. "Additional Reference Resources" on page 38.
- Removed Si4701-specific references and information.
- Updated application note titles and references.



CONTACT INFORMATION

Silicon Laboratories Inc.

4635 Boston Lane
Austin, Texas 78735
Tel: 1+ (512) 416-8500
Fax: 1+ (512) 416-9669
Toll Free: 1+ (877) 444-3032
Email: FMinfo@silabs.com
Internet: www.silabs.com

Confidential

The information in this document is believed to be accurate in all respects at the time of publication but is subject to change without notice. Silicon Laboratories assumes no responsibility for errors and omissions, and disclaims responsibility for any consequences resulting from the use of information included herein. Additionally, Silicon Laboratories assumes no responsibility for the functioning of undescribed features or parameters. Silicon Laboratories reserves the right to make changes without further notice. Silicon Laboratories makes no warranty, representation or guarantee regarding the suitability of its products for any particular purpose, nor does Silicon Laboratories assume any liability arising out of the application or use of any product or circuit, and specifically disclaims any and all liability, including without limitation consequential or incidental damages. Silicon Laboratories products are not designed, intended, or authorized for use in applications intended to support or sustain life, or for any other application in which the failure of the Silicon Laboratories product could create a situation where personal injury or death may occur. Should Buyer purchase or use Silicon Laboratories products for any such unintended or unauthorized application, Buyer shall indemnify and hold Silicon Laboratories harmless against all claims and damages.

Silicon Laboratories and Silicon Labs are trademarks of Silicon Laboratories Inc.
Other products or brand names mentioned herein are trademarks or registered trademarks of their respective holder

Looking for pricing, stock, or lifecycle information?

Click below to explore more details on WIN SOURCE:

 [View SI4700-B15-GMR on WIN SOURCE](#)

 [Silicon Labs](#) Information

Optimize Your Supply Chain with WIN SOURCE Solutions

-  Global Sourcing Solution
-  Obsolete Management
-  Cost Control Management
-  Shortage Management
-  Alternative Solution
-  Excess Inventory Management