



**THE DATASHEET OF  
SI2151-A10-GMR**



### Description

The Si2151 is the industry's most advanced hybrid TV tuner supporting all worldwide terrestrial and cable TV standards for digital and analog TV reception. Leveraging five generations of field-proven hybrid TV tuner technology, the Si2151 delivers the same or better RF performance as Skyworks' Si2157 hybrid TV tuner while further reducing footprint size and bill of materials cost.

Available in an industry-leading 3x3 mm QFN package, the Si2151 eliminates the need for an external balun, LNAs, SAW filters, and inductive power supply filtering to deliver the lowest-cost, most design-friendly and area-efficient solution available today. While competing solutions may also eliminate the balun, they suffer degradation in NF and second-order distortion, compromising reception. A fully-integrated 1.8 V LDO enables single supply operation, while a dual supply option offers additional system flexibility. Increased immunity to LTE interference and a harmonic rejection mixer with outstanding immunity to Wi-Fi interference eliminate the need for external filtering.

For advanced digital broadcast standards with high-order constellations, such as DVB-T2 and DVB-C2, the superior integrated phase noise of the Si2151 provides several dB of improved reception performance compared to competing solutions. Additionally, a software-selectable cable mode offers optimized return loss.

The Si2151 delivers exceptional picture quality and a higher number of received stations when compared to other silicon tuners. Incorporating worldwide field experience from five prior hybrid tuner generations in mass production, the Si2151 delivers the highest tolerance to real-world reception conditions.

### Features

- Worldwide hybrid TV tuner
  - NTSC, PAL/SECAM, ATSC/QAM, DVB-T2/T/C2/C, ISDB-T/C, DTMB
  - 1.7 MHz, 6 MHz, 7 MHz, 8 MHz, and 10 MHz channel bandwidths
- Industry-leading margin to A/74, NorDig, D-Book, C-Book, ARIB, EN55020, OpenCable™, DTMB
- Lowest BOM for a silicon hybrid TV tuner
  - No balun
  - No SAW filters or wire-wound inductors
  - Integrated LNAs and complete tracking filters
- Best-in-class real-world reception
  - Industry-leading phase noise performance
  - High immunity to Wi-Fi and LTE interference
- Low power consumption
  - 3.3 V and 1.8 V power supplies
  - Integrated 1.8 V LDO for 3.3 V single-supply operation
- Integrated power-on reset circuit
- Single LIF output to SoC and/or demodulator
- Standard CMOS process technology
- Smallest footprint for a silicon hybrid TV tuner
  - 3x3 mm, RoHS-compliant 24-pin QFN

### Applications

- Hybrid ½-NIM tuner module
- iDTV (Integrated Digital TV)
- Hybrid terrestrial and cable STB
- Hybrid PVR, DVD and Blu-Ray disc recorder
- PC-TV accessories

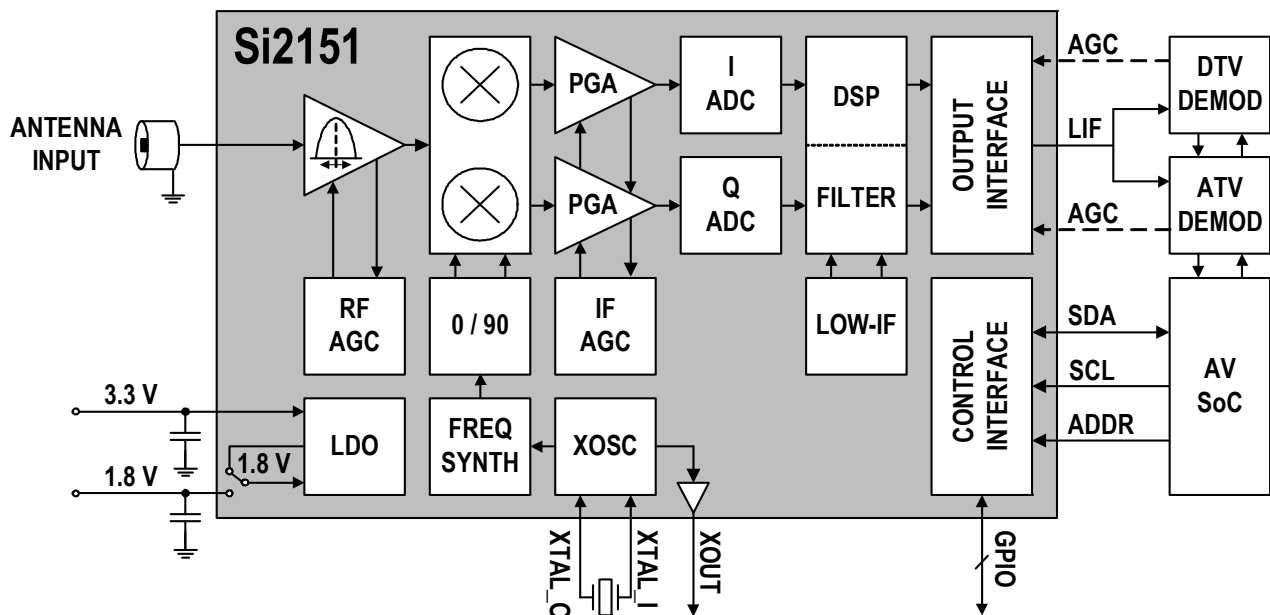
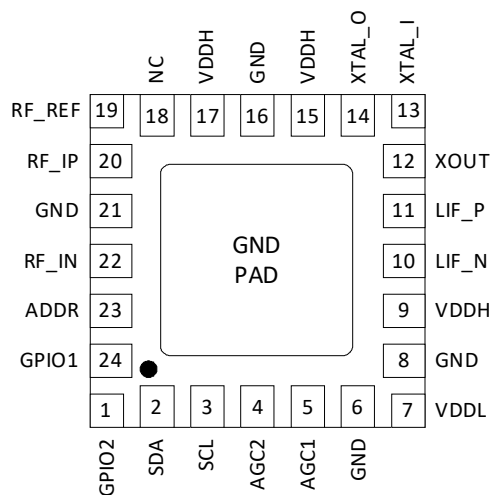

**Table 1. Selected Electrical Specifications**

( $V_{DDH} = 3.3\text{ V}$ ,  $V_{DDL} = 1.8\text{ V}$ ,  $T_A = 25\text{ }^\circ\text{C}$ )

Parameter	Test Condition	Typ	Unit
Supply Voltage		1.8 and 3.3, or only 3.3	V
Total Power Consumption	External 1.8 V supply, ATV Mode	506	mW
RF Input Frequency Range		42 to 1002	MHz
NF, terrestrial*	VHF-L1 (42–103 MHz)	3.6	dB
	VHF-L2 (104–198 MHz)	2.3	dB
	VHF-H (199–470 MHz)	3.0	dB
	UHF (471–870 MHz)	3.2	dB
Return Loss*	Terrestrial mode	3	dB
	Cable mode	8	dB
Out-of-band IIP3*	VHF-H, $N \pm 18$ , $\pm 36$	+5	dBm
In-Band IIP3*	VHF-H, $N \pm 1$ , $\pm 2$	-6	dBm
LO Phase Noise at 860 MHz	1 kHz   10 kHz   100 kHz   1 MHz	-100   -100   -105   -132	dBc/Hz
LO Integrated Phase Noise at 860 MHz	DSB: 125 Hz to 4 MHz offset	0.25 (-47)	$^\circ$ rms (dBc)
Analog IF Spurious Distortion	S=P	-72	dB
LIF Output Center Frequency	Channel BW = 6 MHz   7 MHz   8 MHz	4 to 7   4.5 to 6.5   5 to 6	MHz

### Pin Assignments



### 3x3 mm QFN-24 Package Information

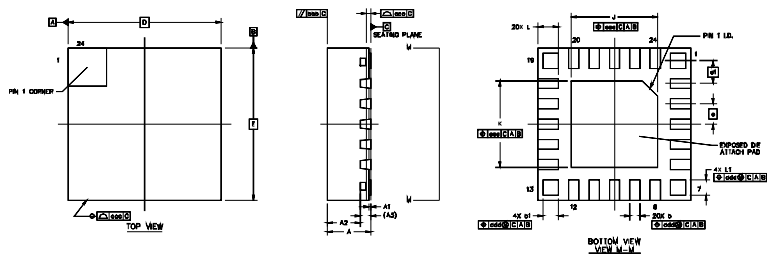

Dimension	Min	Nom	Max	Unit
A	0.80	0.85	0.90	mm
D, E	3.00BSC			mm
e	0.40 BSC			mm
e1	0.45 BSC			mm
J, K	1.60	1.70	1.80	mm

## Looking for pricing, stock, or lifecycle information?

Click below to explore more details on WIN SOURCE:

-  [View SI2151-A10-GMR on WIN SOURCE](#)
-  [Skyworks Solutions Inc. Information](#)

## Optimize Your Supply Chain with WIN SOURCE Solutions

-  Global Sourcing Solution
-  Obsolete Management
-  Cost Control Management
-  Shortage Management
-  Alternative Solution
-  Excess Inventory Management