

DATA SHEET
SE5004L: 5 GHz, 26dBm Power Amplifier with Power Detector

Applications

- DSSS 5 GHz WLAN (IEEE802.11a)
- DSSS 5 GHz WLAN (IEEE802.11n)
- Access Points, PCMCIA, PC cards

Features

- High output power amplifier
 - 26dBm at 5V
- External Analog Reference Voltage (V_{REF}) for maximum flexibility
- Buffered, temperature compensated power detector
- 3% EVM, @26dBm, 64 QAM, 54 Mbps
- 32 dB Gain
- Lead Free, RoHS compliant, halogen free MSL3 package
- 20 pin 4 mm x 4 mm x 0.9 mm QFN

Product Description

The SE5004L is a 5GHz power amplifier offering high linear power for wireless LAN applications. The SE5004L incorporates a power detector for closed loop monitoring and control of the output power.

The SE5004L offers high integration for a simplified design, providing quicker time to market and higher application board production yield. The device integrates the input match, the inter-stage match, the output match, the power detector with 15dB of dynamic range and a 3.8GHz notch filter. Only 6 external decoupling capacitors are required to complete the design.

For wireless LAN applications, the device meets the requirements of IEEE802.11a & 802.11n, and delivers approximately 26dBm of linear output power at 5V.

The SE5004L integrates temperature compensated bias voltage generators. A 2.85V reference voltage on VREF is all that is required to enable or disable the power amplifier.

Ordering Information

Part Number	Package	Remark
SE5004L	20 Pin QFN	Samples
SE5004L-R	20 Pin QFN	Tape and Reel
SE5004L-EK1	Evaluation Kit	Standard

Functional Block Diagram

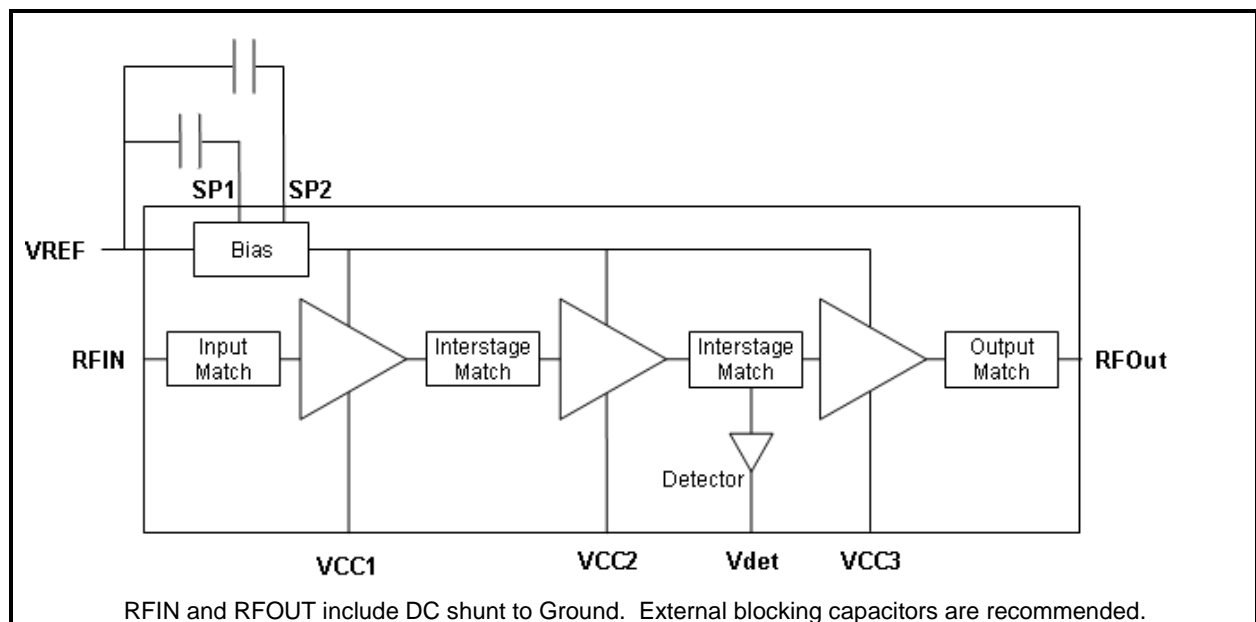

Figure 1: Functional Block Diagram

DATA SHEET
SE5004L: 5 GHz, 26dBm Power Amplifier with Power Detector

Pin Out Diagram

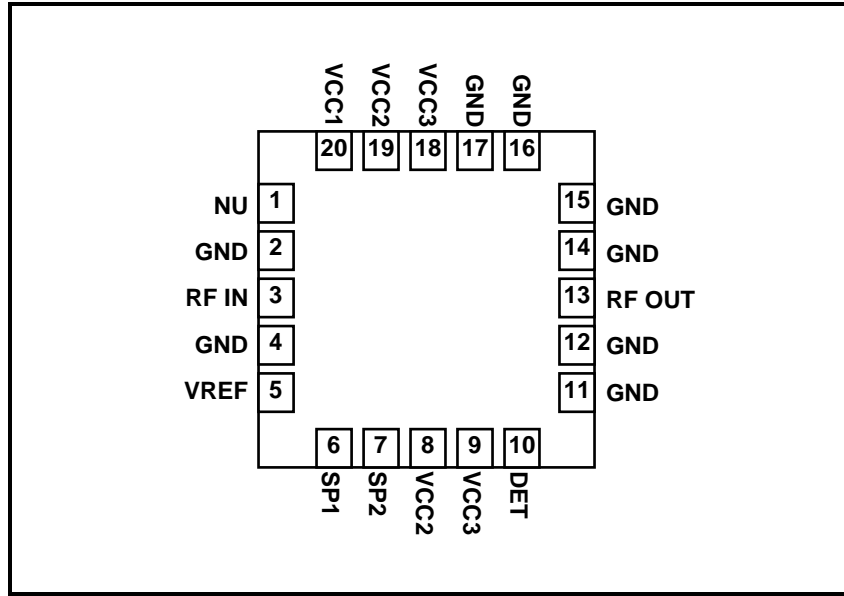

Figure 2: SE5004L Pin Out (Top View Through Package)

Pin Out Description

Pin No.	Name	Description
1	NU	Pin is not used, and is open circuit in the package
2	GND	Ground
3	RFin	Power Amplifier RF input, DC block required
4	GND	Ground
5	V _{REF}	Reference Voltage
6	SP1	Port for optional capacitor to improve dynamic EVM
7	SP2	Port for optional capacitor to improve dynamic EVM
8	VCC2	Second Stage Supply Voltage
9	VCC3	Third Stage Supply Voltage
10	DET	Analog Power Detector Output
11,12	GND	Ground
13	RF OUT	Power Amplifier RF Output
14-17	GND	Ground
18	VCC3	Third Stage Supply Voltage
19	VCC2	Second Stage Supply Voltage
20	VCC1	First Stage Supply Voltage

DATA SHEET

SE5004L: 5 GHz, 26dBm Power Amplifier with Power Detector

Absolute Maximum Ratings

These are stress ratings only. Exposure to stresses beyond these maximum ratings for a long period of time may cause permanent damage to, or affect the reliability of the device. Avoid operating the device outside the recommended operating conditions defined below. This device is ESD sensitive. Handling and assembly of this device should be at ESD protected workstations.

Symbol	Definition	Min.	Max.	Unit
V _{CC}	Supply Voltage on pins VCC3	-0.3	+6	V
	Supply Voltage on pins VCC1, VCC2	-0.3	VCC3	
V _{REF}	Power Amplifier Enable and Reference Voltage	-0.3	3.6	V
R _{FIN}	RF Input Power, R _{Fout} into 50Ω match, T _{CASE_MAX} = 85C	-	6	dBm
T _{STG}	Storage Temperature Range	-40	160	°C
T _j	Maximum Junction Temperature	-	160	°C
ESD _{HBM}	JEDEC JESD22-A114 all pins	-	500	V

Recommended Operating Conditions

Symbol	Parameter	Min.	Max.	Unit
V _{CC}	Supply Voltage VCC3	3.0	5.5	V
	Supply Voltage VCC1, VCC2	3.0	VCC3	
T _{CASE_MAX}	Maximum Case Temperature	-40	85	°C
V _{REF}	Reference Voltage	2.8	2.9	V

DC Electrical Characteristics

Conditions: V_{CC} = 5.0V, V_{REF} = 2.85 V, T_A = 25 °C, as measured on Skyworks Solutions' SE5004L-EK1 evaluation board, unless otherwise noted.

Symbol	Parameter	Conditions	Min.	Typ.	Max.	Unit
I _{CC-802.11a}	Supply Current	P _{OUT} = 26 dBm, 54 Mbps, 64 QAM	-	600	800	mA
I _{QC}	Quiescent Current	No RF	-	300	-	mA
I _{OFF}	Supply Current	V _{REF} = 0 V, No RF	-	0.5	10	μA
I _{EN}	Bias Control Current	V _{REF} = V _{REF H} Internal 2KΩ pull down resistor	-	10	-	mA
V _{REF H}	Reference Voltage Enabled	-	2.80	2.85	2.9	V
V _{REF L}	Reference Voltage Disabled	-	0	-	0.5	V

DATA SHEET

SE5004L: 5 GHz, 26dBm Power Amplifier with Power Detector

AC Electrical Characteristics

802.11a AC Electrical Characteristics

Conditions: $V_{CC} = 5.0\text{ V}$, $V_{REF} = 2.85\text{ V}$, $f = 5.4\text{ GHz}$, $T_A = 25\text{ }^\circ\text{C}$, as measured on Skyworks Solutions' SE5004L-EK1 evaluation board, unless otherwise noted

Symbol	Parameter	Conditions	Min.	Typ.	Max.	Unit
f_{L-U}	Frequency Range	-	5.15	-	5.85	GHz
P_{OUT}	Output Power	802.11a, 54Mbps, 64 QAM, 3% EVM	25.5	26	-	dBm
		802.11a, 54Mbps, 64 QAM, 2.5% EVM	24.5	25	-	
		802.11n, MCS0, Mask Compliant	-	29	-	
P_{1dB}	Output 1dB compression point	No modulation	30	34	-	dBm
S_{21}	Small Signal Gain	$P_{IN} = -25\text{ dBm}$	30	32	-	dB
ΔS_{21}	Gain Variation	Within each UNII Band	-	3	-	dB
$\Delta S_{21\ 3.8}$	Gain at 3.8GHz	$P_{IN} = -25\text{ dBm}$	-	-	0	dB
2f	Harmonic	$P_{OUT} = 26\text{ dBm}$, 5V	-	-	-45	dBm/MHz
3f						
t_r, t_f	Rise and Fall Time	-	-	0.15	0.3	us
STAB	Stability	$P_{OUT} = 26\text{ dBm}$, $V_{CC} = 5V$, 54 Mbps, 64 QAM, $V_{SWR} = 6:1$, all phases	All non-harmonically related outputs less than -50 dBc/100 kHz			
Rugged	Tolerance to constant input power into a mismatch load	$P_{IN} = -10\text{ dBm}$, CW, $V_{SWR} = 6:1$, all phases	No damage			

DATA SHEET
SE5004L: 5 GHz, 26dBm Power Amplifier with Power Detector

Power Detector

Conditions: $V_{CC} = 5.0\text{ V}$, $V_{REF} = 2.85\text{ V}$, $f = 5.4\text{ GHz}$, $T_A = 25\text{ °C}$, as measured on Skyworks Solutions' SE5004L-EK1 evaluation board, unless otherwise noted

Symbol	Parameter	Conditions	Min.	Typ.	Max.	Unit
PDR	P_{OUT} detect range	-	0	-	P_{1dB}	dBm
VDET	Detector voltage	$P_{OUT} = 27\text{ dBm}$	-	1.000	-	V
		$P_{OUT} = \text{NO RF}$	-	0.325	-	V
ERR _{DET}	Detector Accuracy	ΔP_{OUT} at constant V_{DET} , 5.15 GHz – 5.70 GHz	-0.5	-	+0.5	dB
		5.70 GHz – 5.85 GHz	-0.5	-	+0.5	dB
		ΔP_{OUT} at constant V_{DET} , VSWR = 3:1	-1.5		+1.5	dB
PDZ _{OUT}	Output Impedance	-	-	0.7	-	K Ω
PDZ _{LOAD}	DC load impedance	-	-	26.5	-	K Ω

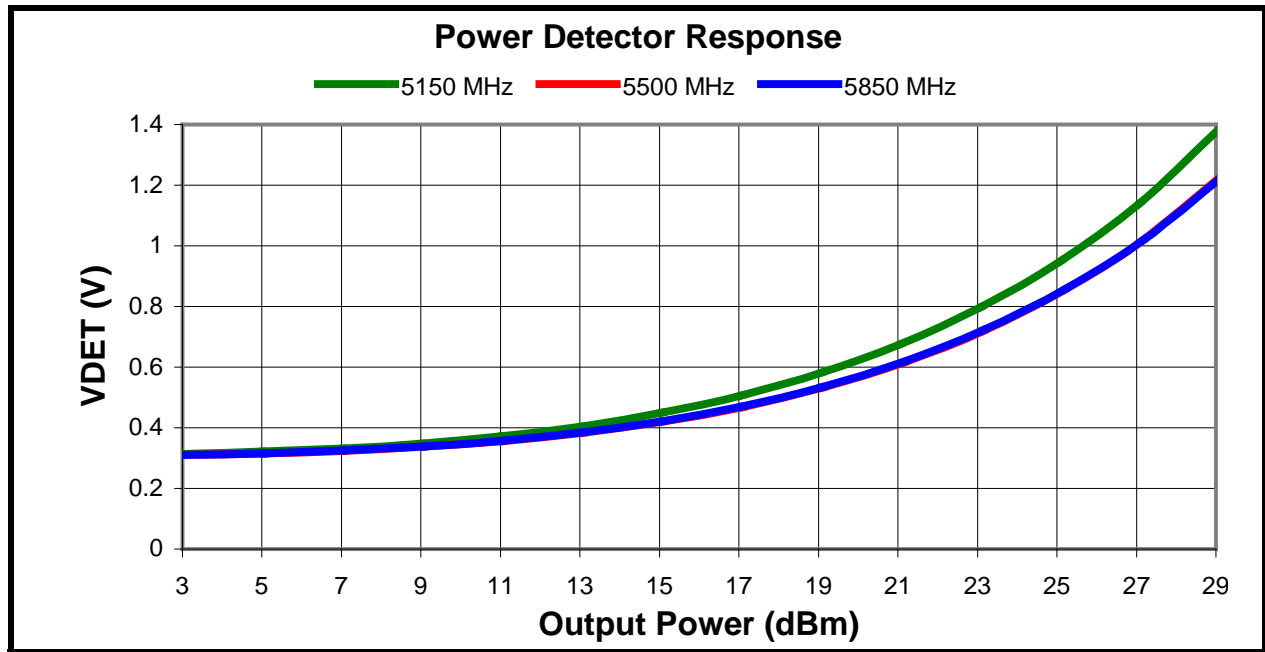
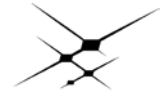

Figure 3: SE5004L Power Detector Characteristic over Frequency



DATA SHEET

SE5004L: 5 GHz, 26dBm Power Amplifier with Power Detector

Package Diagram

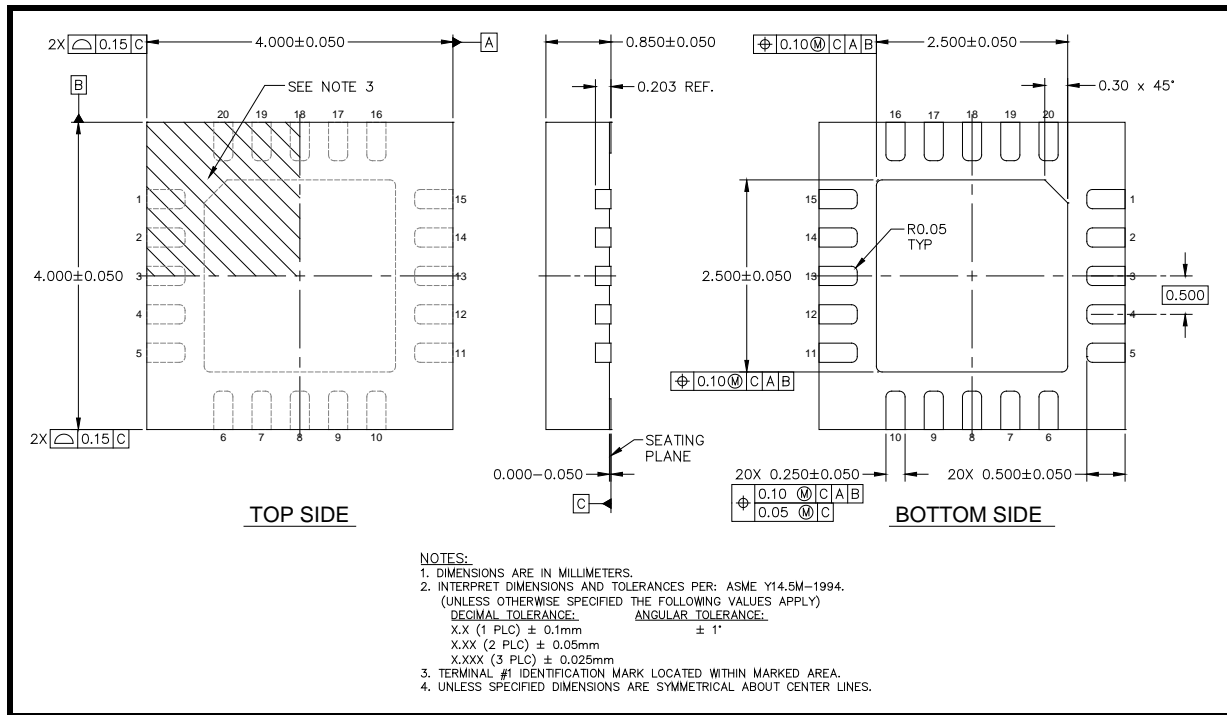
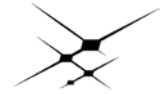

Figure 4: SE5004L Package Information



DATA SHEET

SE5004L: 5 GHz, 26dBm Power Amplifier with Power Detector

Recommended Land and Solder Pattern

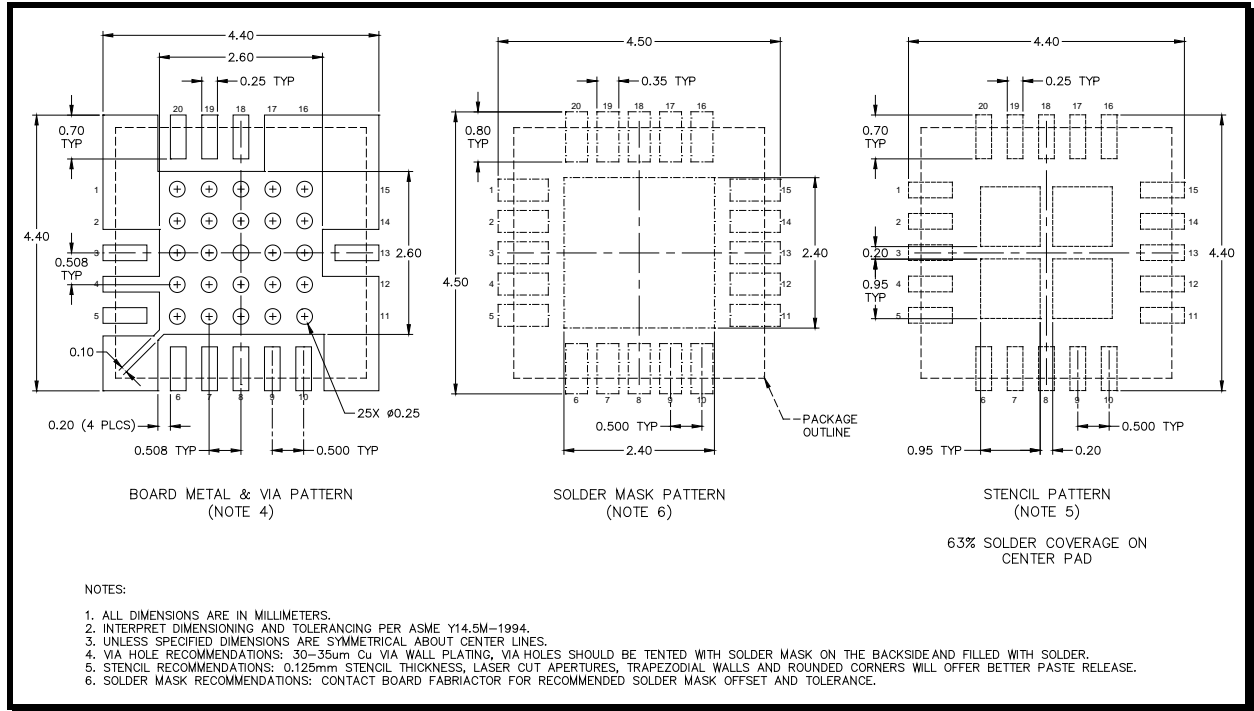

Figure 5: SE5004L Recommended Land Pattern

Package Handling Information

Because of its sensitivity to moisture absorption, instructions on the shipping container label must be followed regarding exposure to moisture after the container seal is broken, otherwise, problems related to moisture absorption may occur when the part is subjected to high temperature during solder assembly. The SE5004L is capable of withstanding a Pb free solder reflow. Care must be taken when attaching this product, whether it is done manually or in a production solder reflow environment. If the part is manually attached, precaution should be taken to insure that the device is not subjected to temperatures above its rated peak temperature for an extended period of time. For details on both attachment techniques, precautions, and handling procedures recommended, please refer to:

- “Quad Flat No-Lead Module Solder Reflow & Rework Information”, *Document Number QAD-00045*
- “Handling, Packing, Shipping and Use of Moisture Sensitive QFN”, *Document Number QAD-00044*



Caution! Class 1B ESD sensitive device

DATA SHEET
SE5004L: 5 GHz, 26dBm Power Amplifier with Power Detector

Branding Information

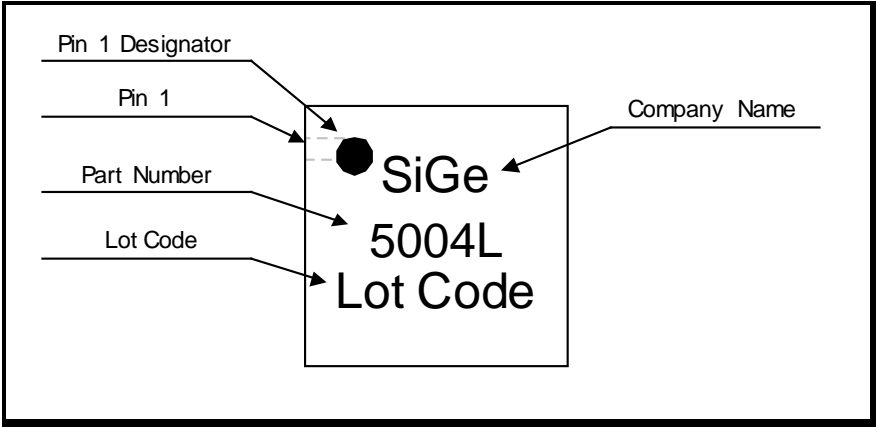

Figure 6: SE5004L Branding Information

Tape and Reel Information

Parameter	Value
Devices Per Reel	3000
Reel Diameter	13 inches
Tape Width	12 millimeters

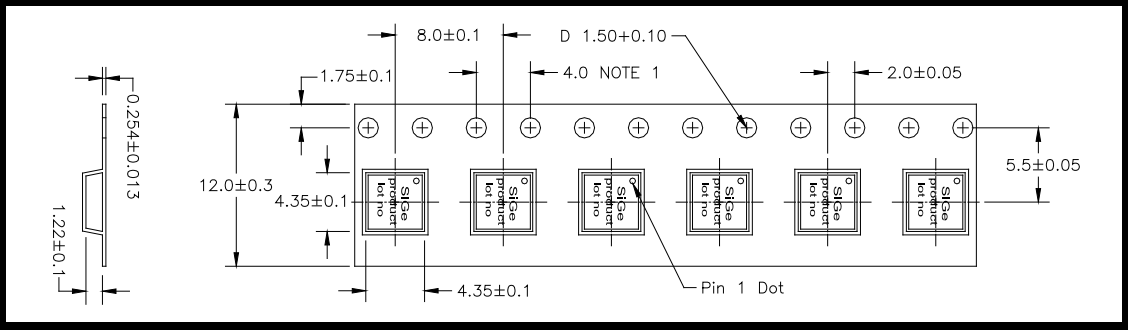

Figure 7: SE5004L-R Tape and Reel Information

DATA SHEET
SE5004L: 5 GHz, 26dBm Power Amplifier with Power Detector

Document Change History

Revision	Date	Notes
1.0	Aug 18, 2009	Created
1.1	Jan 14, 2010	Updated Pinout
1.2	May 4, 2010	Updated harmonic specification
1.3	May 7, 2010	Update T_{RISE} and T_{FALL} time Added MSL rating
1.4	May 20, 2010	Update Recommended Land and Solder Pattern Update detector plot.
1.5	Jul 20, 2010	Extended operating temperature range to -40C to +85C Updated absolute maximum ratings for VCC1 and VCC2 Updated EN pull down resistor value
1.6	Nov 20, 2010	Update Maximum Junction Temperature Updated ESD rating
1.7	Feb 25, 2011	Added Mask compliance Added Vref min/max limits to recommended operating conditions
1.8	Apr 02, 2012	Updated with Skyworks logo and disclaimer statement
1.9	Apr 12, 2012	Added min/max limits to Gain, P1dB, EVM, ICC

Copyright © 2012 Skyworks Solutions, Inc. All Rights Reserved.

Information in this document is provided in connection with Skyworks Solutions, Inc. ("Skyworks") products or services. These materials, including the information contained herein, are provided by Skyworks as a service to its customers and may be used for informational purposes only by the customer. Skyworks assumes no responsibility for errors or omissions in these materials or the information contained herein. Skyworks may change its documentation, products, services, specifications or product descriptions at any time, without notice. Skyworks makes no commitment to update the materials or information and shall have no responsibility whatsoever for conflicts, incompatibilities, or other difficulties arising from any future changes.

No license, whether express, implied, by estoppel or otherwise, is granted to any intellectual property rights by this document. Skyworks assumes no liability for any materials, products or information provided hereunder, including the sale, distribution, reproduction or use of Skyworks products, information or materials, except as may be provided in Skyworks Terms and Conditions of Sale.

THE MATERIALS, PRODUCTS AND INFORMATION ARE PROVIDED "AS IS" WITHOUT WARRANTY OF ANY KIND, WHETHER EXPRESS, IMPLIED, STATUTORY, OR OTHERWISE, INCLUDING FITNESS FOR A PARTICULAR PURPOSE OR USE, MERCHANTABILITY, PERFORMANCE, QUALITY OR NON-INFRINGEMENT OF ANY INTELLECTUAL PROPERTY RIGHT; ALL SUCH WARRANTIES ARE HEREBY EXPRESSLY DISCLAIMED. SKYWORKS DOES NOT WARRANT THE ACCURACY OR COMPLETENESS OF THE INFORMATION, TEXT, GRAPHICS OR OTHER ITEMS CONTAINED WITHIN THESE MATERIALS. SKYWORKS SHALL NOT BE LIABLE FOR ANY DAMAGES, INCLUDING BUT NOT LIMITED TO ANY SPECIAL, INDIRECT, INCIDENTAL, STATUTORY, OR CONSEQUENTIAL DAMAGES, INCLUDING WITHOUT LIMITATION, LOST REVENUES OR LOST PROFITS THAT MAY RESULT FROM THE USE OF THE MATERIALS OR INFORMATION, WHETHER OR NOT THE RECIPIENT OF MATERIALS HAS BEEN ADVISED OF THE POSSIBILITY OF SUCH DAMAGE.



Skyworks products are not intended for use in medical, lifesaving or life-sustaining applications, or other equipment in which the failure of the Skyworks products could lead to personal injury, death, physical or environmental damage. Skyworks customers using or selling Skyworks products for use in such applications do so at their own risk and agree to fully indemnify Skyworks for any damages resulting from such improper use or sale.

Customers are responsible for their products and applications using Skyworks products, which may deviate from published specifications as a result of design defects, errors, or operation of products outside of published parameters or design specifications. Customers should include design and operating safeguards to minimize these and other risks. Skyworks assumes no liability for applications assistance, customer product design, or damage to any equipment resulting from the use of Skyworks products outside of stated published specifications or parameters.

Skyworks, the Skyworks symbol, and "Breakthrough Simplicity" are trademarks or registered trademarks of Skyworks Solutions, Inc., in the United States and other countries. Third-party brands and names are for identification purposes only, and are the property of their respective owners. Additional information, including relevant terms and conditions, posted at www.skyworksinc.com, are incorporated by reference.

Looking for pricing, stock, or lifecycle information?

Click below to explore more details on WIN SOURCE:

-  [View SE5004L on WIN SOURCE](#)
-  [Skyworks Solutions Inc. Information](#)

Optimize Your Supply Chain with WIN SOURCE Solutions

-  Global Sourcing Solution
-  Obsolete Management
-  Cost Control Management
-  Shortage Management
-  Alternative Solution
-  Excess Inventory Management