

# 74ABT821

10-bit D-type flip-flop; positive-edge trigger; 3-state

Rev. 5 — 7 November 2011

Product data sheet

## 1. General description

---

The 74ABT821 high-performance BiCMOS device combines low static and dynamic power dissipation with high speed and high output drive.

The 74ABT821 bus interface register is designed to eliminate the extra packages required to buffer existing registers and provide extra data width for wider data/address paths of buses carrying parity.

The 74ABT821 is a buffered 10-bit wide version of the 74ABT374A.

The 74ABT821 is a 10-bit, edge-triggered register coupled to ten 3-state output buffers. The device is controlled by the clock (CP) and output enable (OE) control gates.

The register is fully edge triggered. The state of each D input, one set-up time before the LOW-to-HIGH clock transition is transferred to the corresponding output Q of the flip-flop.

The 3-state output buffers are designed to drive heavily loaded 3-state buses, MOS memories, or MOS microprocessors.

The active LOW output enable ( $\overline{OE}$ ) controls all ten 3-state buffers independent of the register operation. When  $\overline{OE}$  is LOW, the data in the register appears at the outputs. When  $\overline{OE}$  is HIGH, the outputs are in high-impedance OFF-state, which means they will neither drive nor load the bus.

## 2. Features and benefits

---

- High-speed parallel registers with positive-edge triggered D-type flip-flops
- Ideal where high speed, light loading, or increased fan-in are required with MOS microprocessors
- Output capability: +64 mA and -32 mA
- Power-on 3-state
- Power-on reset
- Latch-up protection exceeds 500 mA per JESD78B class II level A
- ESD protection:
  - ◆ HBM JESD22-A114F exceeds 2000 V
  - ◆ MM JESD22-A115-A exceeds 200 V



### 3. Ordering information

Table 1. Ordering information

Type number	Package			Version
	Temperature range	Name	Description	
74ABT821D	-40 °C to +85 °C	SO24	plastic small outline package; 24 leads; body width 7.5 mm	SOT137-1
74ABT821DB	-40 °C to +85 °C	SSOP24	plastic shrink small outline package; 24 leads; body width 5.3 mm	SOT340-1
74ABT821PW	-40 °C to +85 °C	TSSOP24	plastic thin shrink small outline package; 24 leads; body width 4.4 mm	SOT355-1

### 4. Functional diagram

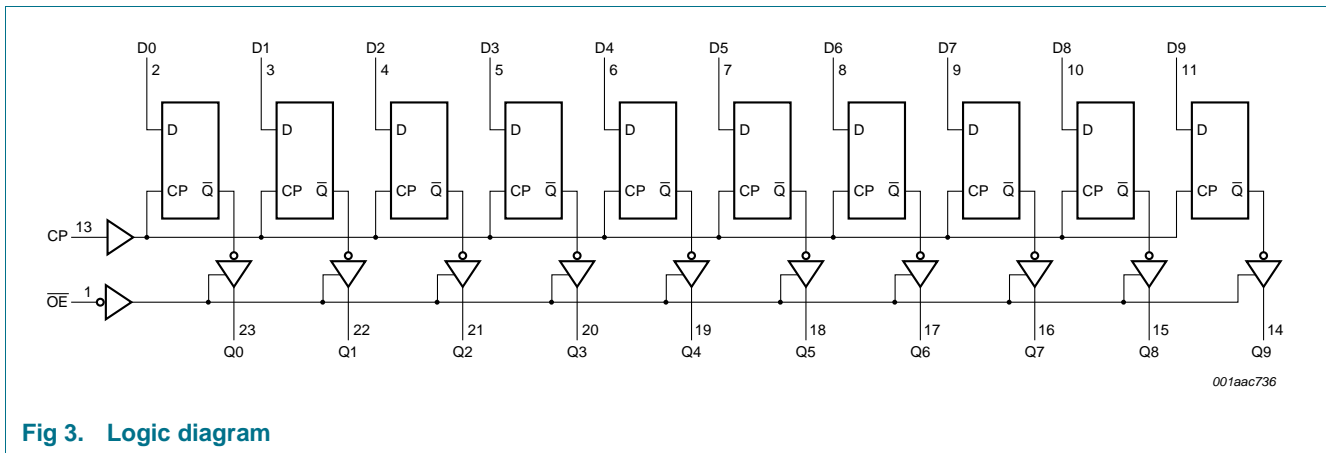
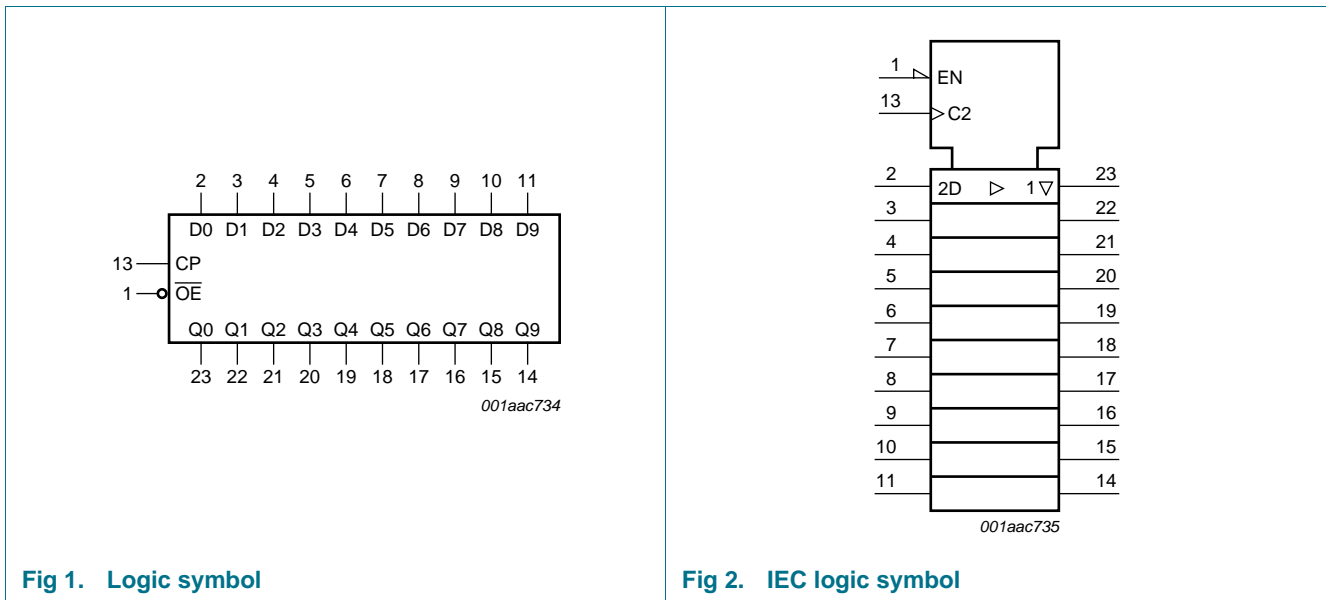

## 5. Pinning information

### 5.1 Pinning

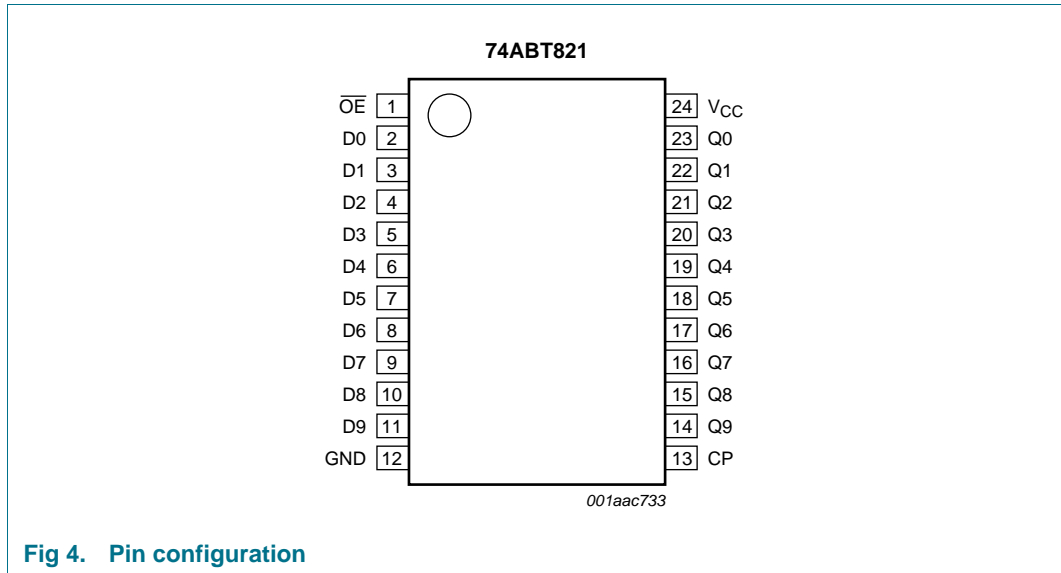

### 5.2 Pin description

**Table 2. Pin description**

Symbol	Pin	Description
$\overline{OE}$	1	output enable input (active LOW)
D0 to D9	2, 3, 4, 5, 6, 7, 8, 9, 10, 11	data input
GND	12	ground (0 V)
CP	13	clock pulse input (active rising edge)
Q0 to Q9	23, 22, 21, 20, 19, 18, 17, 16, 15, 14	data output
V <sub>CC</sub>	24	supply voltage

## 6. Functional description

### 6.1 Function table

Table 3. Function table<sup>[1]</sup>

Input			Internal register	Output Q0 to Q9	Operating mode
OE	CP	D0 to D9			
L	↑	l	L	L	load and read register
L	↑	h	H	H	
L	NC	X	NC	NC	hold
H	NC	X	NC	Z	disable outputs
H	↑	Dn	Dn	Z	

- [1] H = HIGH voltage level;  
 h = HIGH voltage level one set-up time prior to the LOW-to-HIGH clock transition;  
 L = LOW voltage level;  
 l = LOW voltage level one set-up time prior to the LOW-to-HIGH clock transition;  
 NC = no change;  
 X = don't care;  
 Z = high-impedance OFF-state;  
 ↑ = LOW-to-HIGH clock transition.

## 7. Limiting values

**Table 4. Limiting values**

In accordance with the Absolute Maximum Rating System (IEC 60134).

Symbol	Parameter	Conditions	Min	Max	Unit
$V_{CC}$	supply voltage		-0.5	+7.0	V
$V_I$	input voltage		[1] -1.2	+7.0	V
$V_O$	output voltage	output in OFF-state or HIGH-state	[1] -0.5	+5.5	V
$I_{IK}$	input clamping current	$V_I < 0$ V	-18	-	mA
$I_{OK}$	output clamping current	$V_O < 0$ V	-50	-	mA
$I_O$	output current	output in LOW-state	-	128	mA
$T_j$	junction temperature		[2] -	150	°C
$T_{stg}$	storage temperature		-65	+150	°C

[1] The input and output voltage ratings may be exceeded if the input and output current ratings are observed.

[2] The performance capability of a high-performance integrated circuit in conjunction with its thermal environment can create junction temperatures which are detrimental to reliability. The maximum junction temperature of this integrated circuit should not exceed 150 °C.

## 8. Recommended operating conditions

**Table 5. Recommended operating conditions**

Symbol	Parameter	Conditions	Min	Typ	Max	Unit
$V_{CC}$	supply voltage		4.5	-	5.5	V
$V_I$	input voltage		0	-	$V_{CC}$	V
$V_{IH}$	HIGH-level input voltage		2.0	-	-	V
$V_{IL}$	LOW-level input voltage		-	-	0.8	V
$I_{OH}$	HIGH-level output current		-32	-	-	mA
$I_{OL}$	LOW-level output current		-	-	64	mA
$\Delta t/\Delta V$	input transition rise and fall rate		0	-	5	ns/V
$T_{amb}$	ambient temperature	in free air	-40	-	+85	°C

## 9. Static characteristics

Table 6. Static characteristics

Symbol	Parameter	Conditions	25 °C			-40 °C to +85 °C		Unit	
			Min	Typ	Max	Min	Max		
V <sub>IK</sub>	input clamping voltage	V <sub>CC</sub> = 4.5 V; I <sub>IK</sub> = -18 mA	-1.2	-0.9	-	-1.2	-	V	
V <sub>OH</sub>	HIGH-level output voltage	V <sub>I</sub> = V <sub>IL</sub> or V <sub>IH</sub>							
		V <sub>CC</sub> = 4.5 V; I <sub>OH</sub> = -3 mA	2.5	2.9	-	2.5	-	V	
		V <sub>CC</sub> = 5.0 V; I <sub>OH</sub> = -3 mA	3.0	3.4	-	3.0	-	V	
		V <sub>CC</sub> = 4.5 V; I <sub>OH</sub> = -32 mA	2.0	2.4	-	2.0	-	V	
V <sub>OL</sub>	LOW-level output voltage	V <sub>CC</sub> = 4.5 V; I <sub>OL</sub> = 64 mA; V <sub>I</sub> = V <sub>IL</sub> or V <sub>IH</sub>	-	0.42	0.55	-	0.55	V	
V <sub>OL(pu)</sub>	power-up LOW-level output voltage	V <sub>CC</sub> = 5.5 V; I <sub>O</sub> = 1 mA; V <sub>I</sub> = GND or V <sub>CC</sub>	[1]	-	0.13	0.55	-	0.55	V
I <sub>I</sub>	input leakage current	V <sub>CC</sub> = 5.5 V; V <sub>I</sub> = GND or 5.5 V	-	±0.01	±1.0	-	±1.0	μA	
I <sub>OFF</sub>	power-off leakage current	V <sub>CC</sub> = 0 V; V <sub>I</sub> or V <sub>O</sub> ≤ 4.5 V	-	±5.0	±100	-	±100	μA	
I <sub>O(pu/pd)</sub>	power-up/power-down output current	V <sub>CC</sub> = 2.0 V; V <sub>O</sub> = 0.5 V; V <sub>I</sub> = GND or V <sub>CC</sub> ; OE <sub>n</sub> HIGH	[2]	-	±5.0	±50	-	±50	μA
I <sub>OZ</sub>	OFF-state output current	V <sub>CC</sub> = 5.5 V; V <sub>I</sub> = V <sub>IL</sub> or V <sub>IH</sub>							
		V <sub>O</sub> = 2.7 V	-	5.0	50	-	50	μA	
		V <sub>O</sub> = 0.5 V	-	-5.0	-50	-	-50	μA	
I <sub>LO</sub>	output leakage current	HIGH-state; V <sub>O</sub> = 5.5 V; V <sub>CC</sub> = 5.5 V; V <sub>I</sub> = GND or V <sub>CC</sub>	-	5.0	50	-	50	μA	
I <sub>O</sub>	output current	V <sub>CC</sub> = 5.5 V; V <sub>O</sub> = 2.5 V	[3]	-180	-80	-50	-180	-50	mA
I <sub>CC</sub>	supply current	V <sub>CC</sub> = 5.5 V; V <sub>I</sub> = GND or V <sub>CC</sub>							
		outputs HIGH-state	-	0.5	250	-	250	μA	
		outputs LOW-state	-	25	38	-	38	mA	
		outputs disabled	-	0.5	250	-	250	μA	
ΔI <sub>CC</sub>	additional supply current	per input pin; V <sub>CC</sub> = 5.5 V; one input at 3.4 V; other inputs at V <sub>CC</sub> or GND	[4]	-	0.5	1.5	-	1.5	mA
C <sub>I</sub>	input capacitance	V <sub>I</sub> = 0 V or V <sub>CC</sub>	-	4	-	-	-	pF	
C <sub>O</sub>	output capacitance	outputs disabled; V <sub>O</sub> = 0 V or V <sub>CC</sub>	-	7	-	-	-	pF	

[1] For valid test results, data must not be loaded into the flip-flops (or latches) after applying the power.

[2] This parameter is valid for any V<sub>CC</sub> between 0 V and 2.1 V with a transition time of up to 10 ms. For V<sub>CC</sub> = 2.1 V to V<sub>CC</sub> = 5 V ± 10 %, a transition time of up to 100 μs is permitted.

[3] Not more than one output should be tested at a time, and the duration of the test should not exceed one second.

[4] This is the increase in supply current for each input at 3.4 V.

## 10. Dynamic characteristics

**Table 7. Dynamic characteristics**  
*GND = 0 V; for test circuit, see Figure 8.*

Symbol	Parameter	Conditions	25 °C; V <sub>CC</sub> = 5.0 V			-40 °C to +70 °C; V <sub>CC</sub> = 5.0 V ± 0.5 V		Unit
			Min	Typ	Max	Min	Max	
t <sub>PLH</sub>	LOW to HIGH propagation delay	CP to Qn; see Figure 5	2.1	4.1	5.6	2.1	6.2	ns
t <sub>PHL</sub>	HIGH to LOW propagation delay	CP to Qn; see Figure 5	2.8	4.6	6.2	2.8	6.7	ns
t <sub>PZH</sub>	OFF-state to HIGH propagation delay	$\overline{O}E_n$ to Qn; see Figure 6	1.0	3.0	4.5	1.0	5.3	ns
t <sub>PZL</sub>	OFF-state to LOW propagation delay	$\overline{O}E_n$ to Qn; see Figure 6	2.2	4.1	5.6	2.2	6.3	ns
t <sub>PHZ</sub>	HIGH to OFF-state propagation delay	$\overline{O}E_n$ to Qn; see Figure 6	2.7	4.7	6.2	2.7	6.7	ns
t <sub>PLZ</sub>	LOW to OFF-state propagation delay	$\overline{O}E_n$ to Qn; see Figure 6	2.3	4.6	6.1	2.3	6.5	ns
t <sub>su(H)</sub>	set-up time HIGH	Dn to CP; see Figure 7	2.1	0.5	-	2.1	-	ns
t <sub>su(L)</sub>	set-up time LOW	Dn to CP; see Figure 7	2.1	0.3	-	2.1	-	ns
t <sub>h(H)</sub>	hold time HIGH	Dn to CP; see Figure 7	1.3	0	-	1.3	-	ns
t <sub>h(L)</sub>	hold time LOW	Dn to CP; see Figure 7	1.3	-0.3	-	1.3	-	ns
t <sub>WH</sub>	pulse width HIGH	CP; see Figure 5	2.9	1.8	-	2.9	-	ns
t <sub>WL</sub>	pulse width LOW	CP; see Figure 5	3.8	2.8	-	3.8	-	ns
f <sub>max</sub>	maximum frequency	see Figure 5	125	185	-	125	-	MHz

## 11. Waveforms

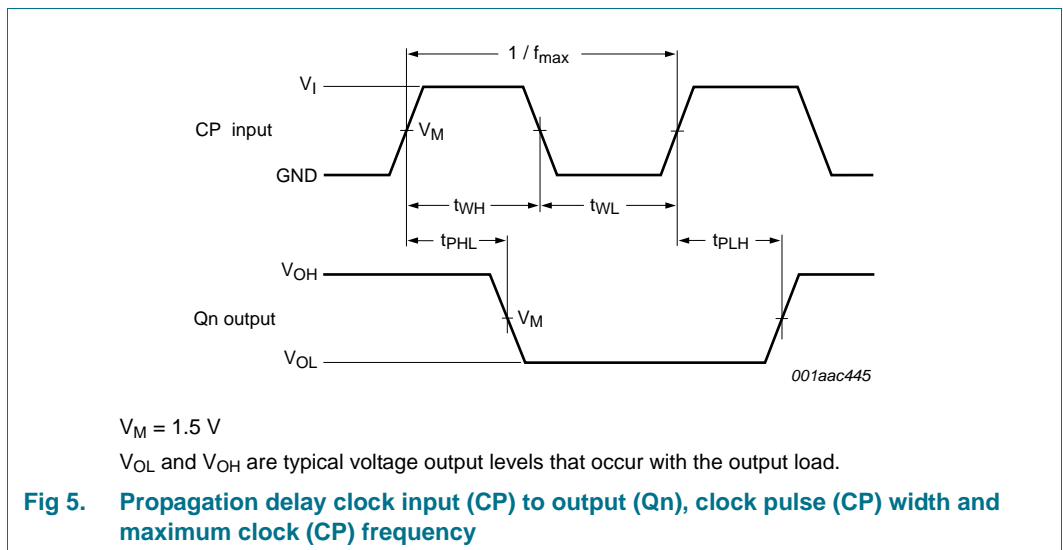

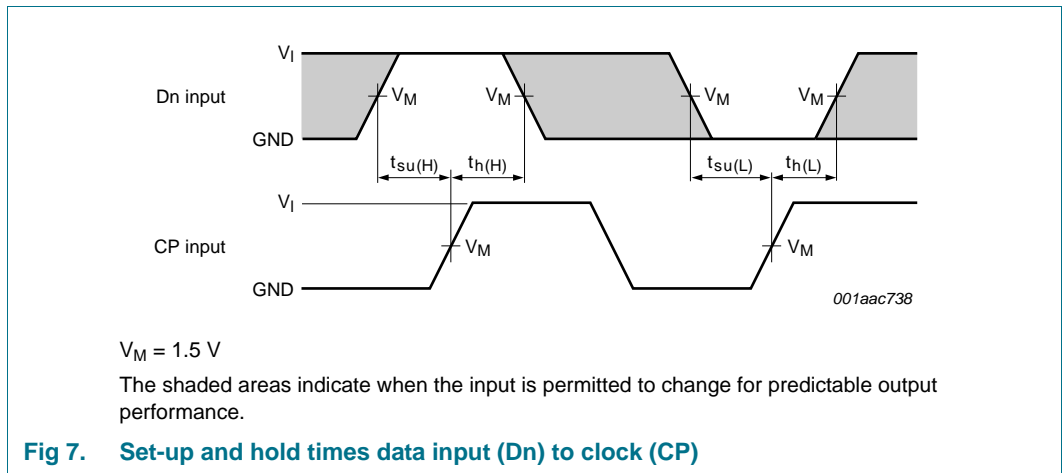
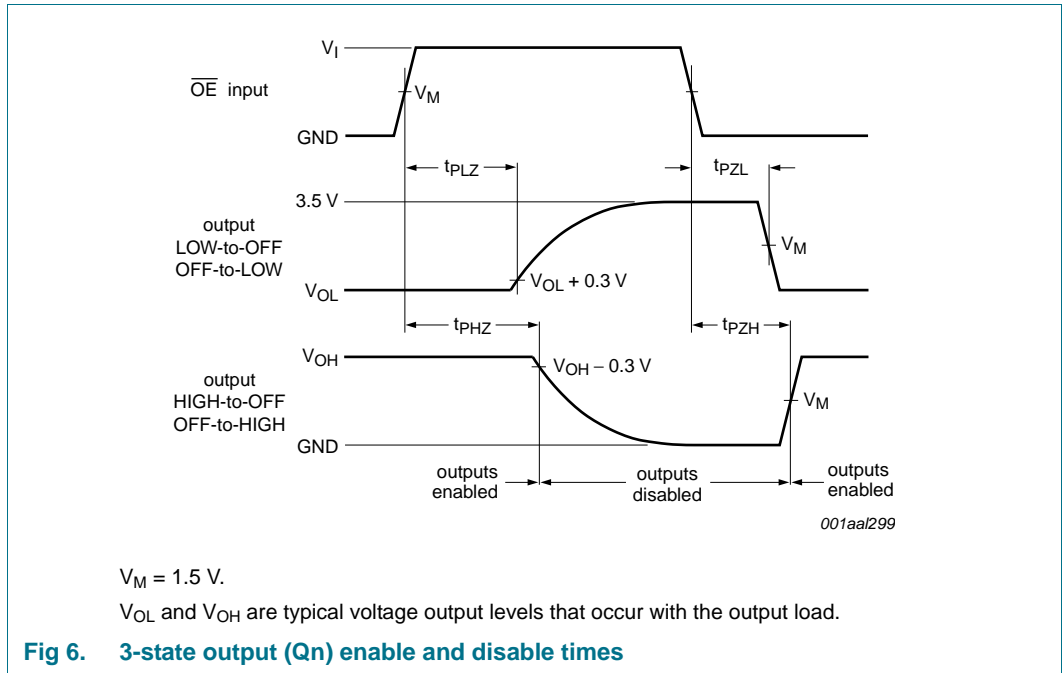

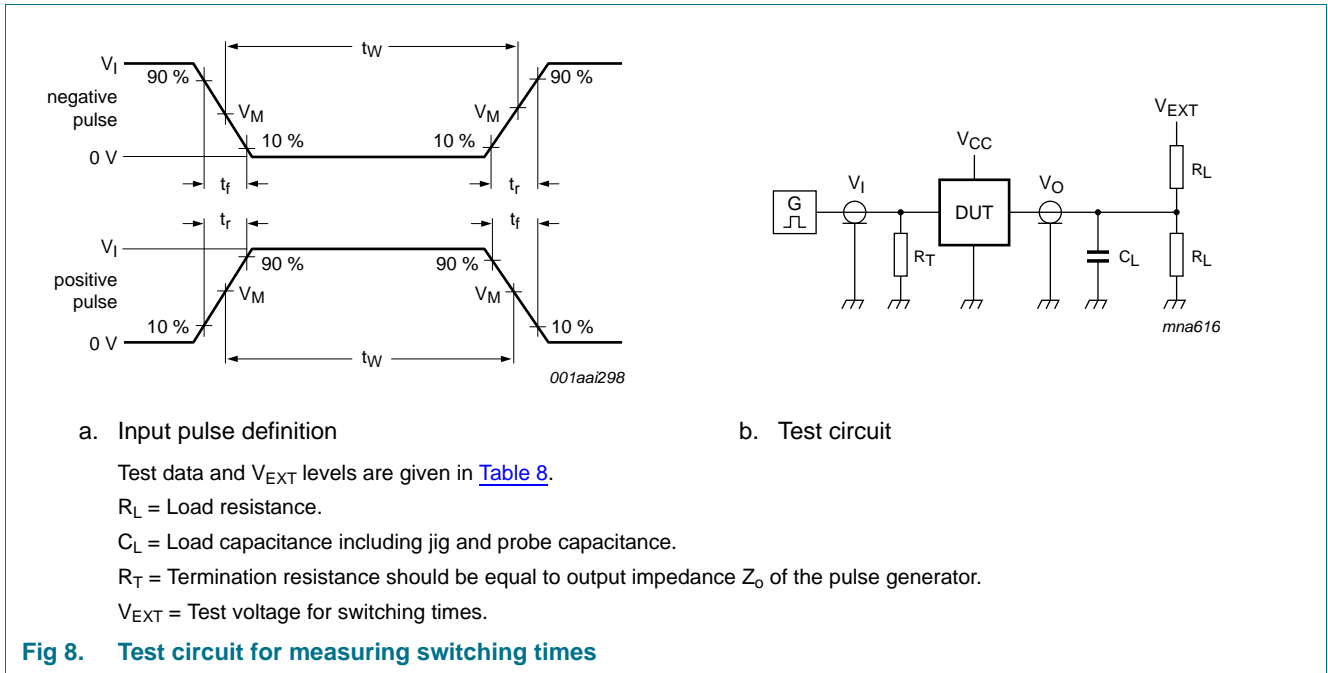

Fig 8. Test circuit for measuring switching times

Table 8. Test data

Input				Load		$V_{EXT}$		
$V_I$	$f_I$	$t_W$	$t_r, t_f$	$C_L$	$R_L$	$t_{PHL}, t_{PLH}$	$t_{PZH}, t_{PHZ}$	$t_{PZL}, t_{PLZ}$
3.0 V	1 MHz	500 ns	$\leq 2.5$ ns	50 pF	500 $\Omega$	open	open	7.0 V

12. Package outline

SO24: plastic small outline package; 24 leads; body width 7.5 mm

SOT137-1

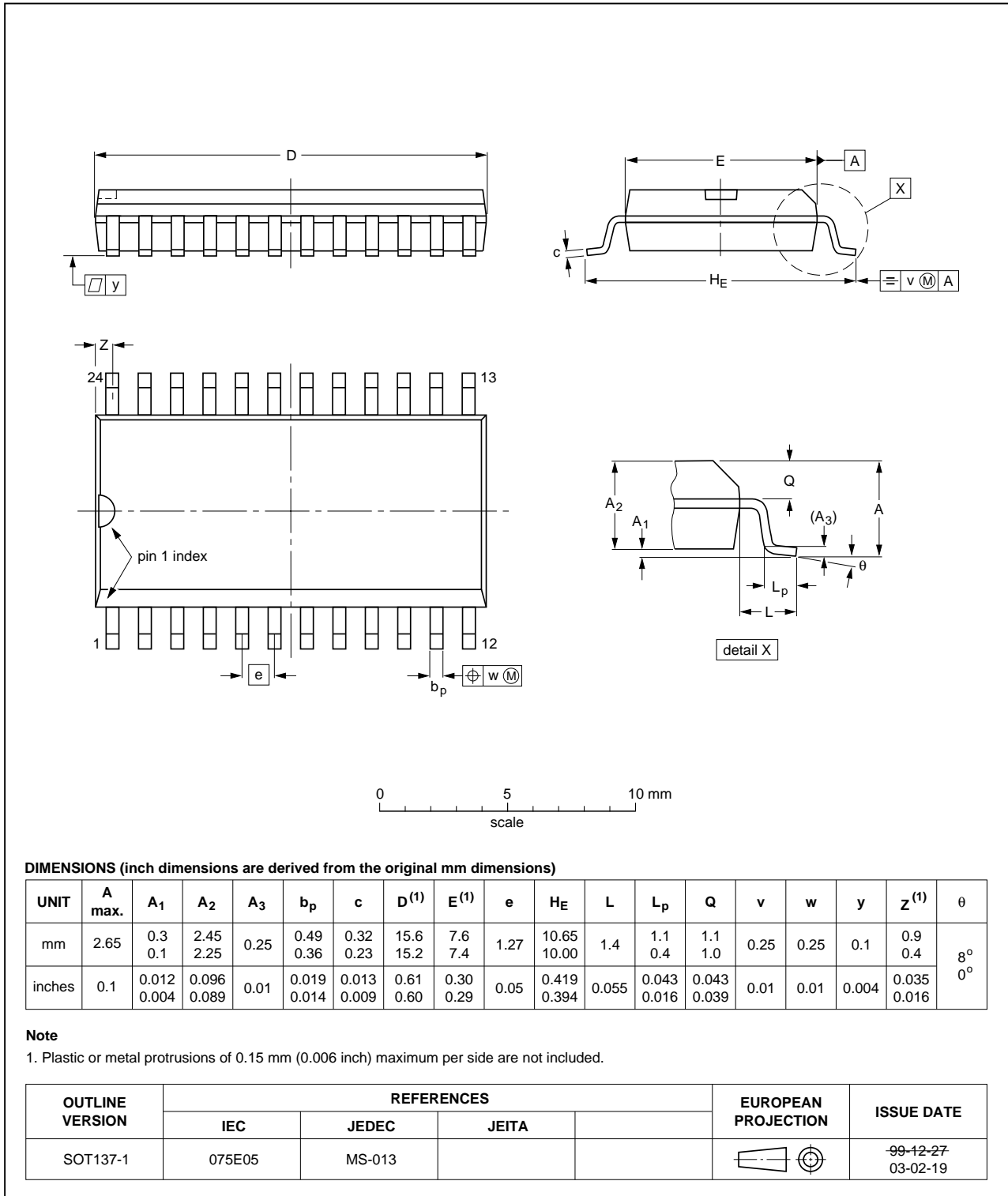

Fig 9. Package outline SOT137-1 (SO24)

SSOP24: plastic shrink small outline package; 24 leads; body width 5.3 mm

SOT340-1

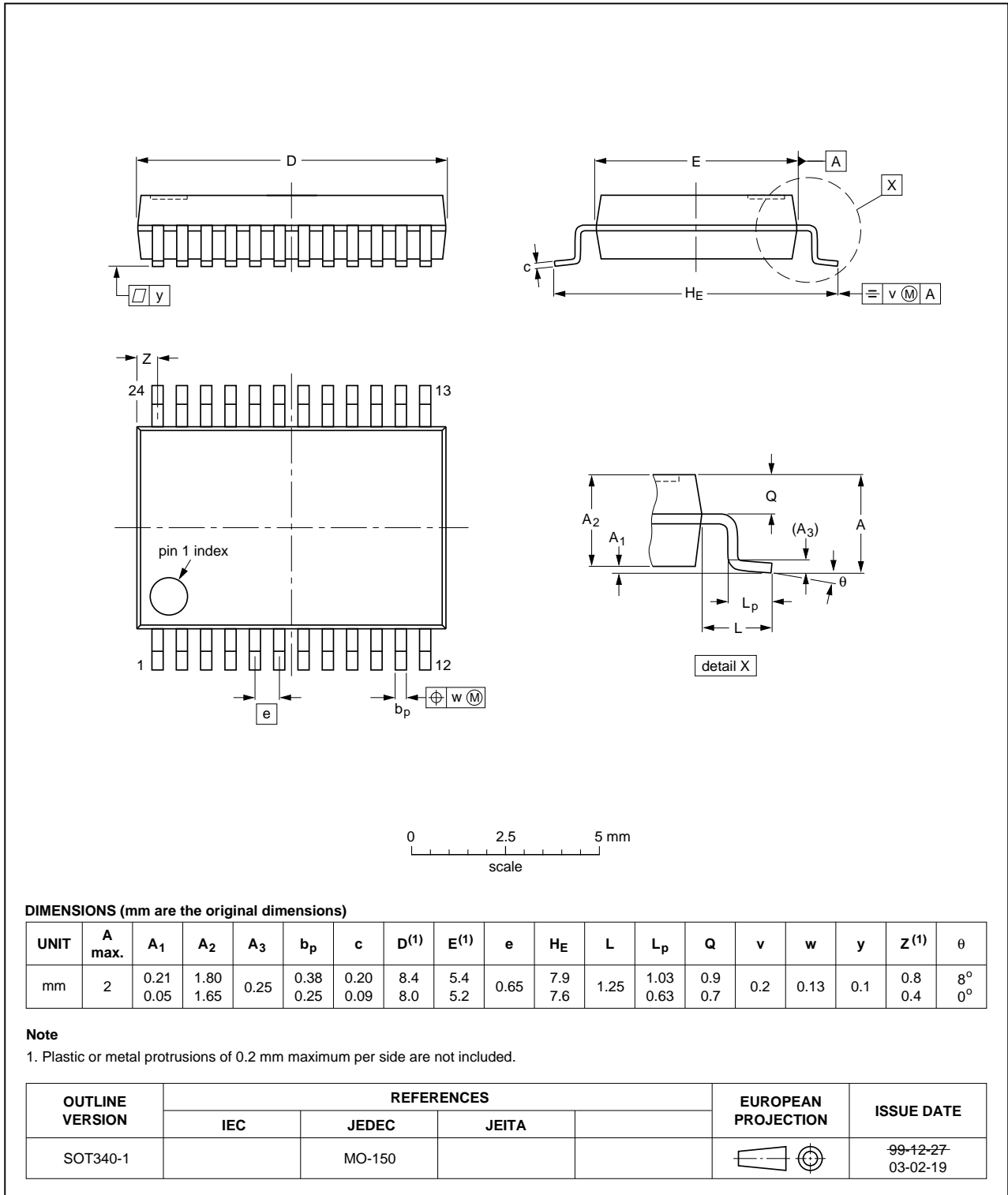

Fig 10. Package outline SOT340-1 (SSOP24)

TSSOP24: plastic thin shrink small outline package; 24 leads; body width 4.4 mm

SOT355-1

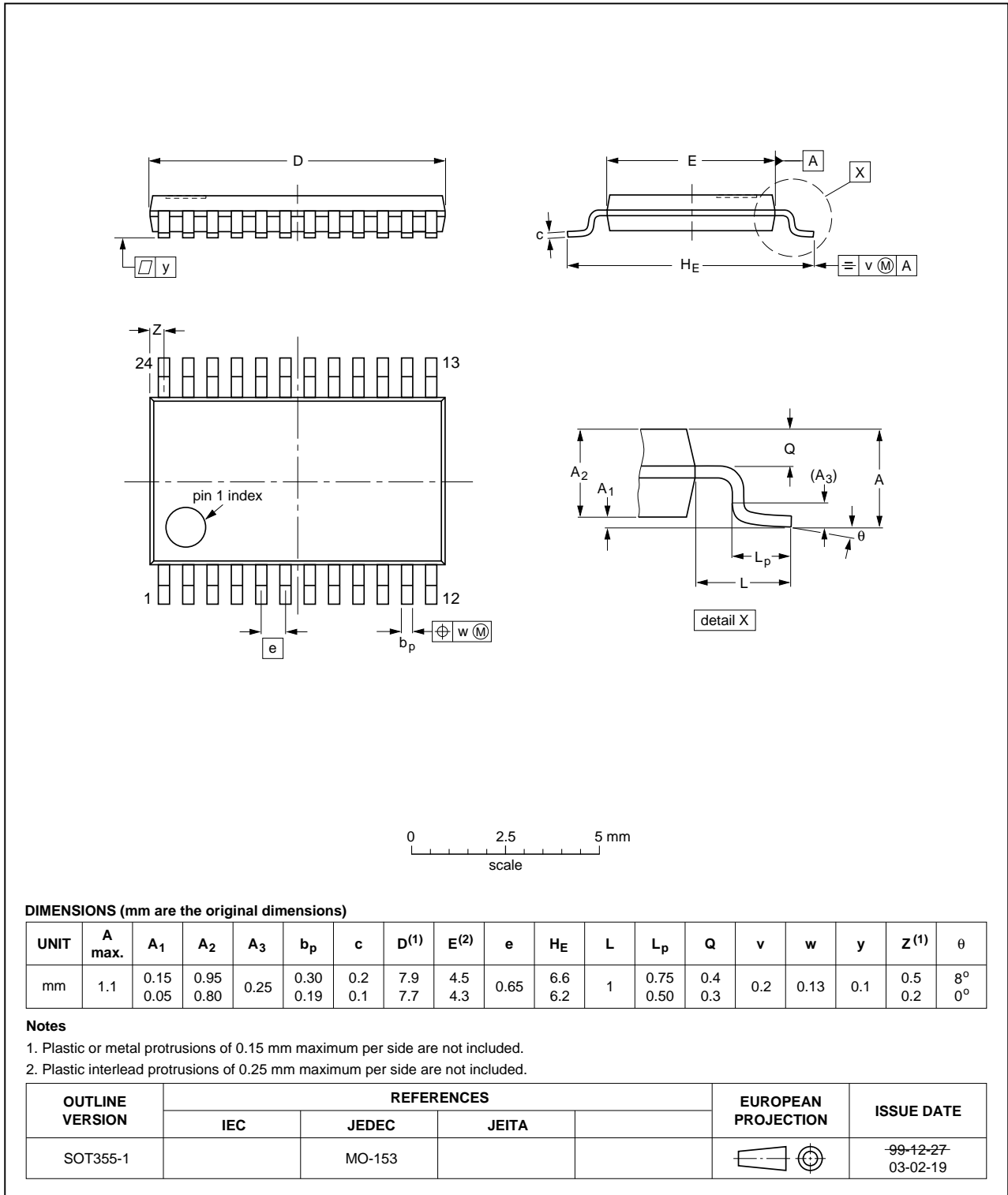

Fig 11. Package outline SOT355-1 (TSSOP24)

## 13. Abbreviations

Table 9. Abbreviations

Acronym	Description
BiCMOS	Bipolar Complementary Metal-Oxide Semiconductor
DUT	Device Under Test
ESD	ElectroStatic Discharge
HBM	Human Body Model
MM	Machine Model

## 14. Revision history

Table 10. Revision history

Document ID	Release date	Data sheet status	Change notice	Supersedes
74ABT821 v.5	20111107	Product data sheet	-	74ABT821 v.4
Modifications:	<ul style="list-style-type: none"> <li>Legal pages updated.</li> </ul>			
74ABT821 v.4	20100326	Product data sheet	-	74ABT821 v.3
74ABT821 v.3	20100225	Product data sheet	-	74ABT821 v.2
74ABT821 v.2	20050412	Product specification	-	74ABT821
74ABT821	19950906	Product specification	-	-

## 15. Legal information

### 15.1 Data sheet status

Document status <sup>[1][2]</sup>	Product status <sup>[3]</sup>	Definition
Objective [short] data sheet	Development	This document contains data from the objective specification for product development.
Preliminary [short] data sheet	Qualification	This document contains data from the preliminary specification.
Product [short] data sheet	Production	This document contains the product specification.

[1] Please consult the most recently issued document before initiating or completing a design.

[2] The term 'short data sheet' is explained in section "Definitions".

[3] The product status of device(s) described in this document may have changed since this document was published and may differ in case of multiple devices. The latest product status information is available on the Internet at URL <http://www.nxp.com>.

### 15.2 Definitions

**Draft** — The document is a draft version only. The content is still under internal review and subject to formal approval, which may result in modifications or additions. NXP Semiconductors does not give any representations or warranties as to the accuracy or completeness of information included herein and shall have no liability for the consequences of use of such information.

**Short data sheet** — A short data sheet is an extract from a full data sheet with the same product type number(s) and title. A short data sheet is intended for quick reference only and should not be relied upon to contain detailed and full information. For detailed and full information see the relevant full data sheet, which is available on request via the local NXP Semiconductors sales office. In case of any inconsistency or conflict with the short data sheet, the full data sheet shall prevail.

**Product specification** — The information and data provided in a Product data sheet shall define the specification of the product as agreed between NXP Semiconductors and its customer, unless NXP Semiconductors and customer have explicitly agreed otherwise in writing. In no event however, shall an agreement be valid in which the NXP Semiconductors product is deemed to offer functions and qualities beyond those described in the Product data sheet.

### 15.3 Disclaimers

**Limited warranty and liability** — Information in this document is believed to be accurate and reliable. However, NXP Semiconductors does not give any representations or warranties, expressed or implied, as to the accuracy or completeness of such information and shall have no liability for the consequences of use of such information.

In no event shall NXP Semiconductors be liable for any indirect, incidental, punitive, special or consequential damages (including - without limitation - lost profits, lost savings, business interruption, costs related to the removal or replacement of any products or rework charges) whether or not such damages are based on tort (including negligence), warranty, breach of contract or any other legal theory.

Notwithstanding any damages that customer might incur for any reason whatsoever, NXP Semiconductors' aggregate and cumulative liability towards customer for the products described herein shall be limited in accordance with the *Terms and conditions of commercial sale* of NXP Semiconductors.

**Right to make changes** — NXP Semiconductors reserves the right to make changes to information published in this document, including without limitation specifications and product descriptions, at any time and without notice. This document supersedes and replaces all information supplied prior to the publication hereof.

**Suitability for use** — NXP Semiconductors products are not designed, authorized or warranted to be suitable for use in life support, life-critical or safety-critical systems or equipment, nor in applications where failure or

malfunction of an NXP Semiconductors product can reasonably be expected to result in personal injury, death or severe property or environmental damage. NXP Semiconductors accepts no liability for inclusion and/or use of NXP Semiconductors products in such equipment or applications and therefore such inclusion and/or use is at the customer's own risk.

**Applications** — Applications that are described herein for any of these products are for illustrative purposes only. NXP Semiconductors makes no representation or warranty that such applications will be suitable for the specified use without further testing or modification.

Customers are responsible for the design and operation of their applications and products using NXP Semiconductors products, and NXP Semiconductors accepts no liability for any assistance with applications or customer product design. It is customer's sole responsibility to determine whether the NXP Semiconductors product is suitable and fit for the customer's applications and products planned, as well as for the planned application and use of customer's third party customer(s). Customers should provide appropriate design and operating safeguards to minimize the risks associated with their applications and products.

NXP Semiconductors does not accept any liability related to any default, damage, costs or problem which is based on any weakness or default in the customer's applications or products, or the application or use by customer's third party customer(s). Customer is responsible for doing all necessary testing for the customer's applications and products using NXP Semiconductors products in order to avoid a default of the applications and the products or of the application or use by customer's third party customer(s). NXP does not accept any liability in this respect.

**Limiting values** — Stress above one or more limiting values (as defined in the Absolute Maximum Ratings System of IEC 60134) will cause permanent damage to the device. Limiting values are stress ratings only and (proper) operation of the device at these or any other conditions above those given in the Recommended operating conditions section (if present) or the Characteristics sections of this document is not warranted. Constant or repeated exposure to limiting values will permanently and irreversibly affect the quality and reliability of the device.

**Terms and conditions of commercial sale** — NXP Semiconductors products are sold subject to the general terms and conditions of commercial sale, as published at <http://www.nxp.com/profile/terms>, unless otherwise agreed in a valid written individual agreement. In case an individual agreement is concluded only the terms and conditions of the respective agreement shall apply. NXP Semiconductors hereby expressly objects to applying the customer's general terms and conditions with regard to the purchase of NXP Semiconductors products by customer.

**No offer to sell or license** — Nothing in this document may be interpreted or construed as an offer to sell products that is open for acceptance or the grant, conveyance or implication of any license under any copyrights, patents or other industrial or intellectual property rights.

**Export control** — This document as well as the item(s) described herein may be subject to export control regulations. Export might require a prior authorization from competent authorities.

**Non-automotive qualified products** — Unless this data sheet expressly states that this specific NXP Semiconductors product is automotive qualified, the product is not suitable for automotive use. It is neither qualified nor tested in accordance with automotive testing or application requirements. NXP Semiconductors accepts no liability for inclusion and/or use of non-automotive qualified products in automotive equipment or applications.

In the event that customer uses the product for design-in and use in automotive applications to automotive specifications and standards, customer (a) shall use the product without NXP Semiconductors' warranty of the product for such automotive applications, use and specifications, and (b) whenever customer uses the product for automotive applications beyond

NXP Semiconductors' specifications such use shall be solely at customer's own risk, and (c) customer fully indemnifies NXP Semiconductors for any liability, damages or failed product claims resulting from customer design and use of the product for automotive applications beyond NXP Semiconductors' standard warranty and NXP Semiconductors' product specifications.

## 15.4 Trademarks

Notice: All referenced brands, product names, service names and trademarks are the property of their respective owners.

## 16. Contact information

For more information, please visit: <http://www.nxp.com>

For sales office addresses, please send an email to: [salesaddresses@nxp.com](mailto:salesaddresses@nxp.com)

## 17. Contents

<b>1</b>	<b>General description</b> .....	<b>1</b>
<b>2</b>	<b>Features and benefits</b> .....	<b>1</b>
<b>3</b>	<b>Ordering information</b> .....	<b>2</b>
<b>4</b>	<b>Functional diagram</b> .....	<b>2</b>
<b>5</b>	<b>Pinning information</b> .....	<b>3</b>
5.1	Pinning .....	3
5.2	Pin description .....	3
<b>6</b>	<b>Functional description</b> .....	<b>4</b>
6.1	Function table .....	4
<b>7</b>	<b>Limiting values</b> .....	<b>5</b>
<b>8</b>	<b>Recommended operating conditions</b> .....	<b>5</b>
<b>9</b>	<b>Static characteristics</b> .....	<b>6</b>
<b>10</b>	<b>Dynamic characteristics</b> .....	<b>7</b>
<b>11</b>	<b>Waveforms</b> .....	<b>7</b>
<b>12</b>	<b>Package outline</b> .....	<b>10</b>
<b>13</b>	<b>Abbreviations</b> .....	<b>13</b>
<b>14</b>	<b>Revision history</b> .....	<b>13</b>
<b>15</b>	<b>Legal information</b> .....	<b>14</b>
15.1	Data sheet status .....	14
15.2	Definitions .....	14
15.3	Disclaimers .....	14
15.4	Trademarks .....	15
<b>16</b>	<b>Contact information</b> .....	<b>15</b>
<b>17</b>	<b>Contents</b> .....	<b>16</b>

Please be aware that important notices concerning this document and the product(s) described herein, have been included in section 'Legal information'.

© NXP B.V. 2011.

All rights reserved.

For more information, please visit: <http://www.nxp.com>



For sales office addresses, please send an email to: [salesaddresses@nxp.com](mailto:salesaddresses@nxp.com)

Date of release: 7 November 2011

Document identifier: 74ABT821

## Looking for pricing, stock, or lifecycle information?

Click below to explore more details on WIN SOURCE:

-  [View 74ABT821D,623 on WIN SOURCE](#)
-  [NXP / Nexperia Information](#)

## Optimize Your Supply Chain with WIN SOURCE Solutions

-  Global Sourcing Solution
-  Obsolete Management
-  Cost Control Management
-  Shortage Management
-  Alternative Solution
-  Excess Inventory Management