

Auxiliary Switch Diodes for Snubber SARS01, SARS05

Data Sheet

Description

The SARS01/05 is an auxiliary switch diode especially designed for snubber circuits, which are used in the primary sides of flyback switched-mode power supplies.

Being capable of reducing the ringing voltage generated at power MOSFET turn-off, the SARS01/05-incorporated snubber circuits allow better cross regulation of multiple outputs.

The SARS01/05 can also improve power supply efficiency by partially transferring such ringing voltage into the secondary side of a power supply unit.

Features

- Improves Cross Regulation
- Reduces Noise
- Improves Efficiency

Applications

For switched-mode power supplies (SMPS) with flyback topology such as:

- White Goods
- Adaptor
- Industrial Equipment

Typical Application

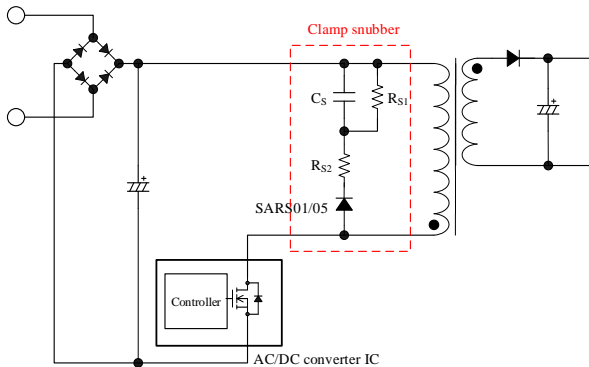

Package

- SARS01
Axial ($\phi 2.7 \times 5.0L / \phi 0.6$)



- SARS05
SJP ($4.5 \text{ mm} \times 2.6 \text{ mm}$)

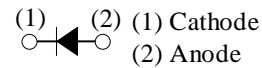
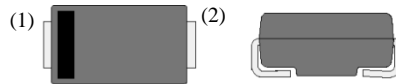

Not to scale

Selection Guide

Part Number	$I_{F(AV)}$	V_F (max.)	Package
SARS01	1.2 A	0.92 V	Axial
SARS05	1.0 A	1.05 V	SJP

Contents

Description	1
Contents	2
Absolute Maximum Ratings	3
Electrical Characteristics	3
SARS01 Rating and Characteristic Curves.....	4
SARS05 Rating and Characteristic Curves.....	5
SARS01 Physical Dimensions and Marking Diagram	7
SARS05 Physical Dimensions and Marking Diagram	8
Operational Comparison of Clamp Snubber Circuits.....	10
Power Dissipation and Junction Temperature Calculation	11
Parameter Setting of Snubber Circuit using SARS01/05	11
Reference Design of Power Supply	12
Important Notes.....	14

SARS01, SARS05

Absolute Maximum Ratings

Unless otherwise specified, $T_A = 25\text{ }^\circ\text{C}$.

Parameter	Symbol	Conditions	Rating	Unit	Remarks
Transient Peak Reverse Voltage	V_{RSM}		800	V	
Peak Repetitive Reverse Voltage	V_{RM}		800	V	
Average Forward Current ⁽¹⁾	$I_{F(AV)}$		1.2	A	SARS01
			1.0		SARS05
Surge Forward Current	I_{FSM}	Half cycle sine wave, positive side, 10 ms, 1 shot	110	A	SARS01
			30		SARS05
I^2t Limiting Value	I^2t	$1\text{ ms} \leq t \leq 10\text{ ms}$	60.5	A^2s	SARS01
			4.5		SARS05
Junction Temperature	T_J		-40 to 150	$^\circ\text{C}$	
Storage Temperature	T_{STG}		-40 to 150	$^\circ\text{C}$	

Electrical Characteristics

Unless otherwise specified, $T_A = 25\text{ }^\circ\text{C}$.

Parameter	Symbol	Conditions	Min.	Typ.	Max.	Unit	Remarks
Forward Voltage Drop	V_F	$I_F = 1.2\text{ A}$	—	—	0.92	V	SARS01
		$I_F = 1.5\text{ A}$	—	—	1.05		SARS05
Reverse Leakage Current	I_R	$V_R = V_{RM}$	—	—	10	μA	SARS01
			—	—	5		SARS05
Reverse Leakage Current under High Temperature	$H \cdot I_R$	$V_R = V_{RM}$, $T_J = 100\text{ }^\circ\text{C}$	—	—	50	μA	
Reverse Recovery Time	t_{rr}	$I_F = I_{RP} = 100\text{ mA}$, $T_J = 25\text{ }^\circ\text{C}$, 90% recovery point	2	—	18	μs	SARS01
			2	—	19		SARS05
Thermal Resistance	$R_{th(J-L)}$	⁽²⁾	—	—	20	$^\circ\text{C/W}$	SARS01
			—	—	20		SARS05

⁽¹⁾ See the derating curves of each product.

⁽²⁾ $R_{th(J-L)}$ is thermal resistance between junction and lead.

SARS01 Rating and Characteristic Curves

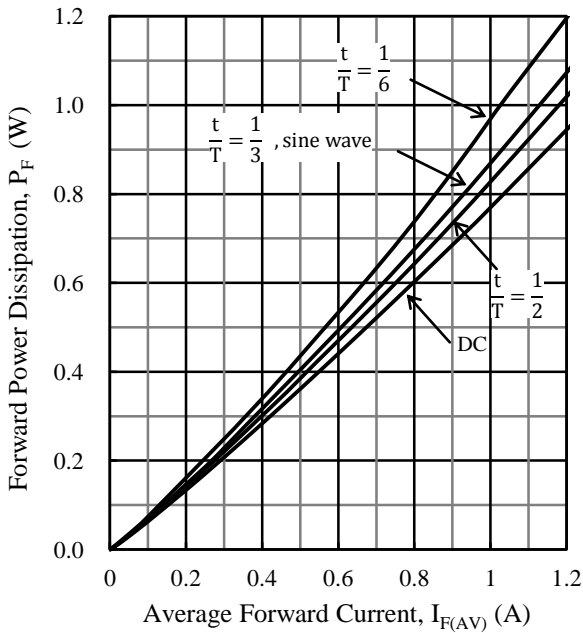

Figure 1. SARS01 $I_{F(AV)}$ vs. P_F Power Dissipation Curves ($T_J = 150^\circ\text{C}$)

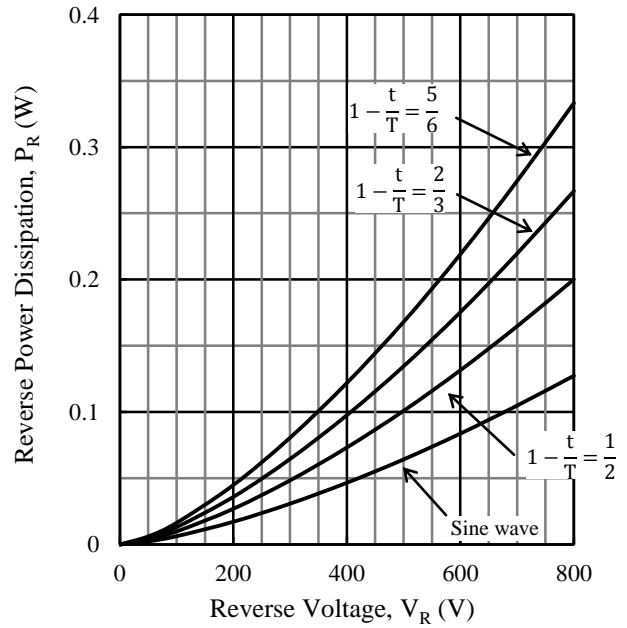

Figure 2. SARS01 V_R vs. P_R Power Dissipation Curves ($T_J = 150^\circ\text{C}$)

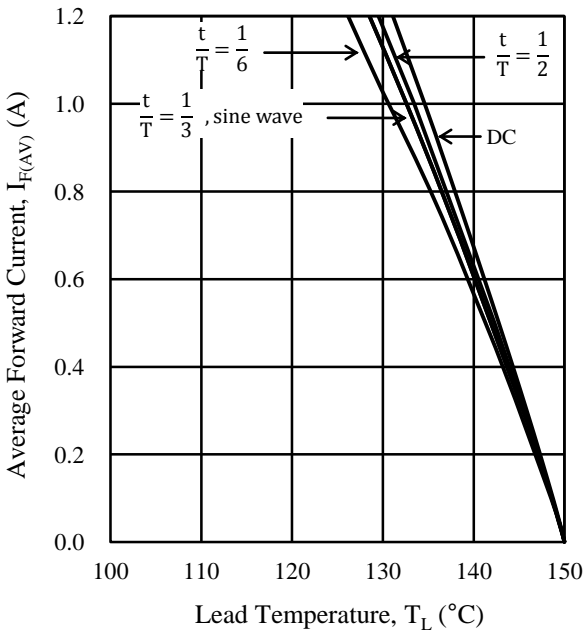

Figure 3. SARS01 T_L vs. $I_{F(AV)}$ Derating Curves ($V_R = 0\text{ V}$, $T_J = 150^\circ\text{C}$)

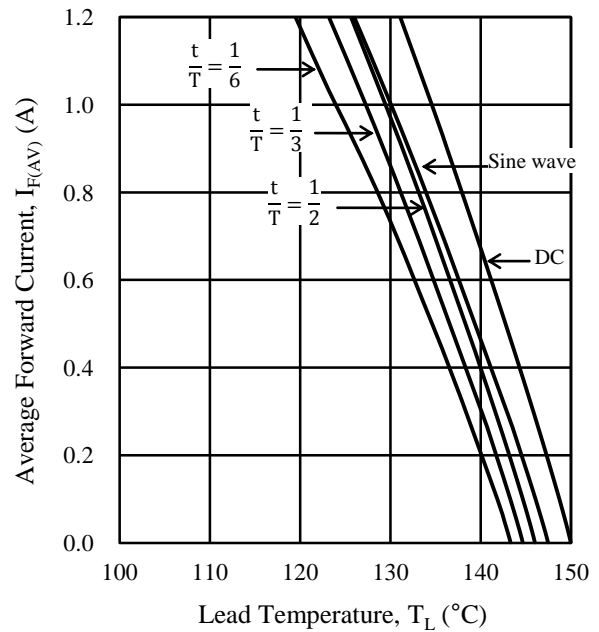

Figure 4. SARS01 T_L vs. $I_{F(AV)}$ Derating Curves ($V_R = 800\text{ V}$, $T_J = 150^\circ\text{C}$)

SARS01, SARS05

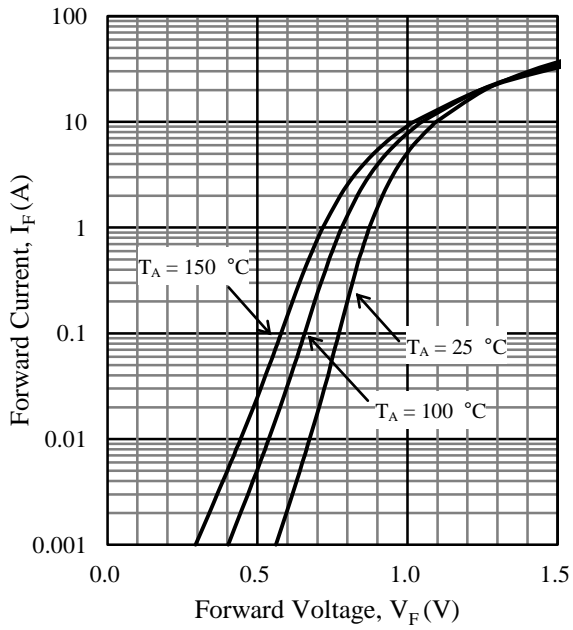

Figure 5. SARS01 V_F vs. I_F Typical Characteristics

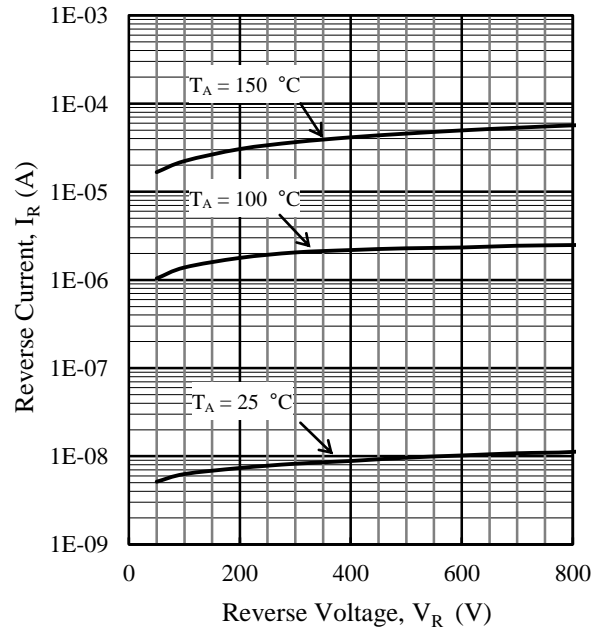

Figure 6. SARS01 V_R vs. I_R Typical Characteristics

SARS05 Rating and Characteristic Curves

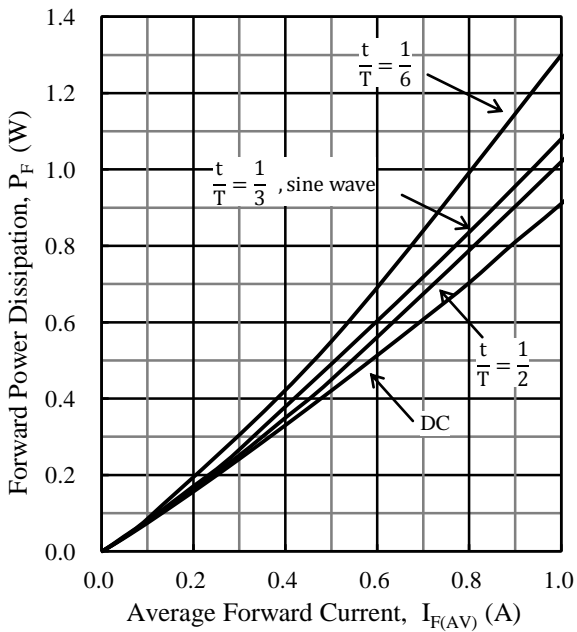

Figure 7. SARS05 $I_{F(AV)}$ vs. P_F Power Dissipation Curves ($T_J = 150\text{ °C}$)

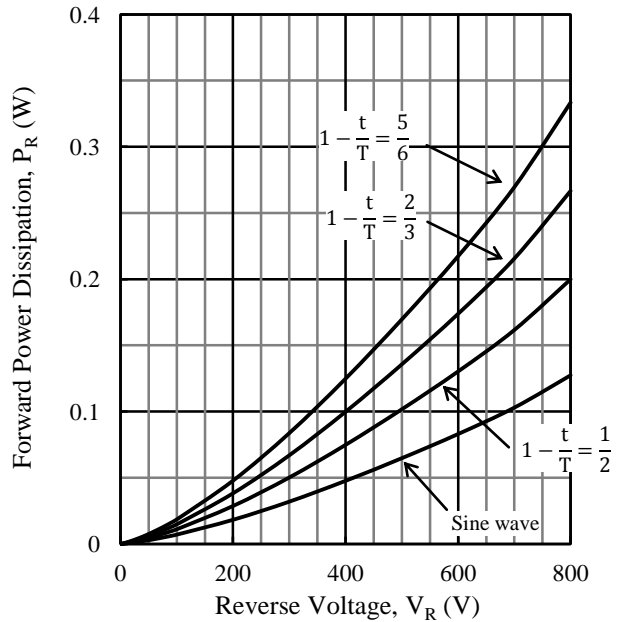

Figure 8. SARS05 V_R vs. P_R Power Dissipation Curves ($T_J = 150\text{ °C}$)

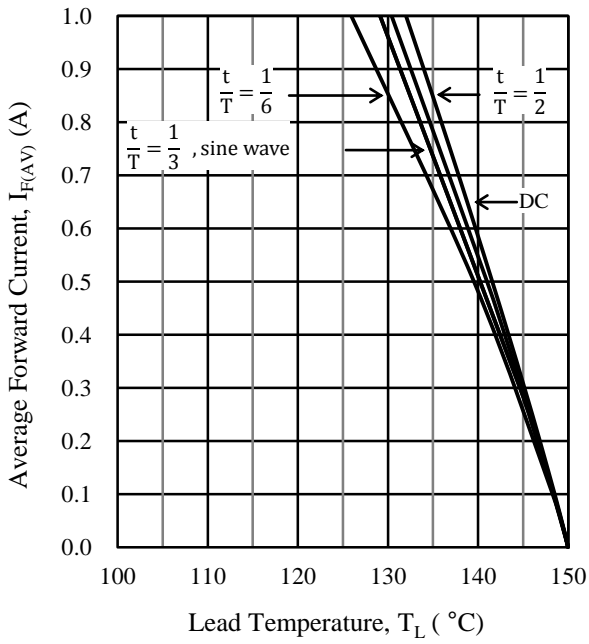

Figure 9. SARS05 T_L vs. $I_{F(AV)}$ Derating Curves ($V_R = 0$ V, $T_J = 150$ °C)

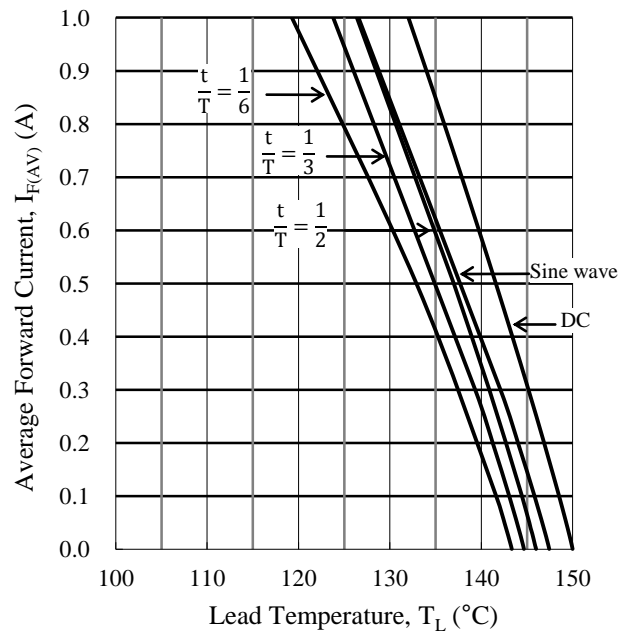

Figure 10. SARS05 T_L vs. $I_{F(AV)}$ Derating Curves ($V_R = 800$ V, $T_J = 150$ °C)

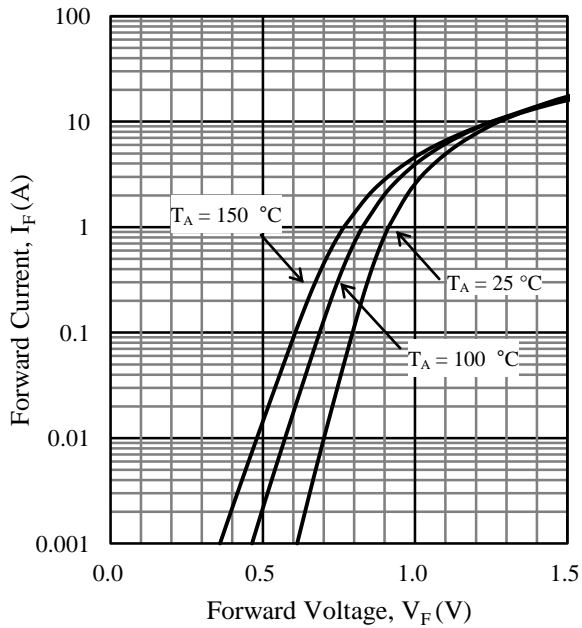

Figure 11. SARS05 V_F vs. I_F Typical Characteristics

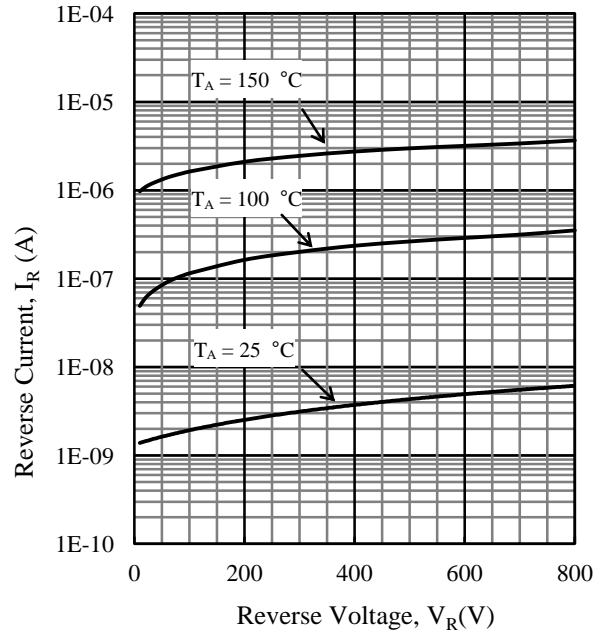
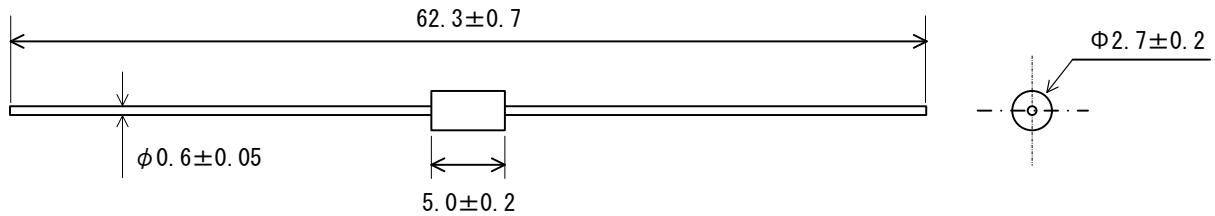

Figure 12. SARS05 V_R vs. I_R Typical Characteristics

SARS01 Physical Dimensions and Marking Diagram

• SARS01 Physical Dimensions

Axial ($\phi 2.7 \times 5.0L / \phi 0.6$)



NOTES:

- Dimensions in millimeters
- Bare leads: Pb-free (RoHS compliant)
- When soldering the products, it is required to minimize the working time, within the following limits:
 - Flow: 260 ± 5 °C / 10 ± 1 s, 2 times
 - Soldering Iron: 380 ± 10 °C / 3.5 ± 0.5 s, 1 time (Soldering should be at a distance of at least 1.5 mm from the body of the product.)

• SARS01 Marking Diagram

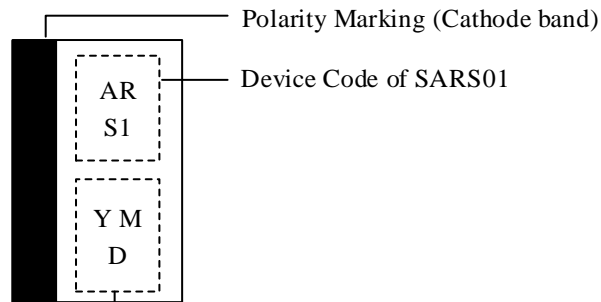

Lot Number:

Y is the last digit of the year of manufacture (0 to 9)

M is the month of the year (1 to 9, O, N, or D)

D is a period of days:

“.” is the first 10 days of the month (1st to 10th)

“..” is the second 10 days of the month (11th to 20th)

“...” is the last 10–11 days of the month (21st to 31st)

SARS05 Physical Dimensions and Marking Diagram

• SARS05 Physical Dimensions

- SJP Physical Dimensions

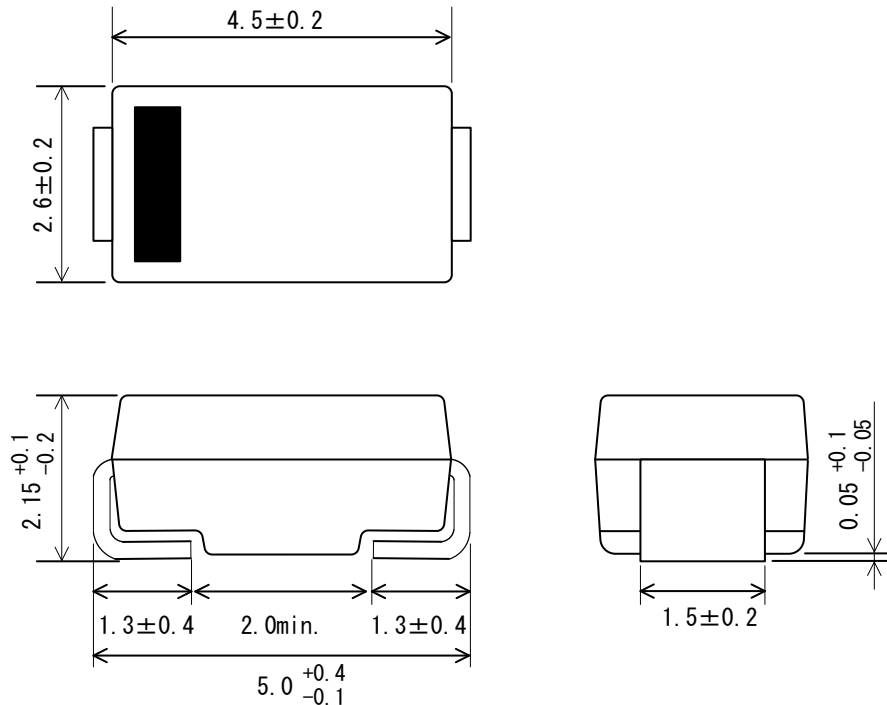

NOTES:

- Dimensions in millimeters
- Bare lead frame: Pb-free (RoHS compliant)
- When soldering the products, it is required to minimize the working time, within the following limits:
Reflow (MSL 3)
Preheat: $180\text{ °C} / 90 \pm 30\text{ s}$
Solder heating: $250\text{ °C} / 10 \pm 1\text{ s}$, 2 times (260 °C peak)
Soldering iron: $380 \pm 10\text{ °C} / 3.5 \pm 0.5\text{ s}$, 1 time

• SARS05 Land Pattern Example

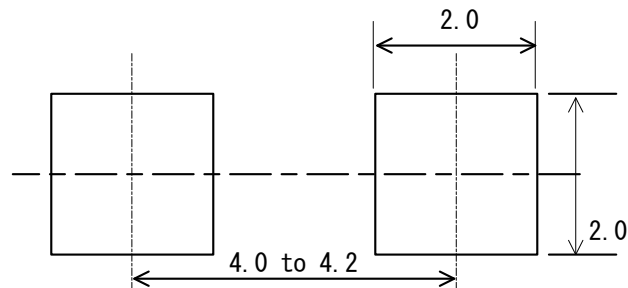

SARS01, SARS05

- SARS05 Marking Diagram

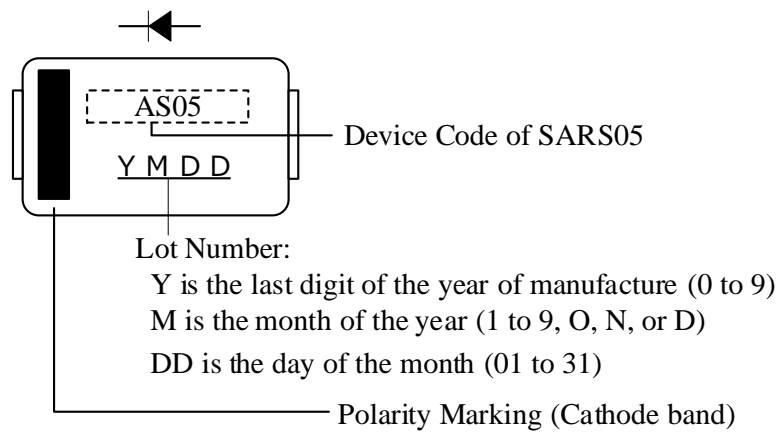

Operational Comparison of Clamp Snubber Circuits

Figure 13 shows a general clamp snubber circuit. In the circuit, the surge voltage at tuning off a power MOSFET is charged to C_S through the surge absorb loop, and is consumed by R_{S1} through the energy discharge loop. All the consumed energy becomes loss in R_{S1} . In addition, the ringing of surge voltage results in poor cross regulation of multi-outputs.

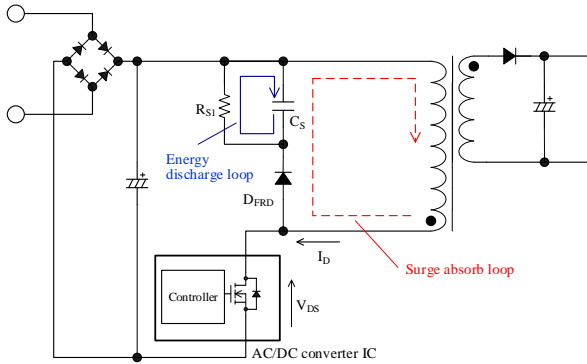

Figure 13. General Clamp Snubber Circuit

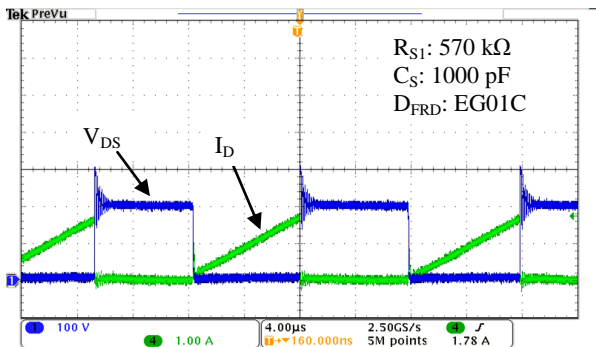

Figure 14. Waveforms of General Clamp Snubber Circuit

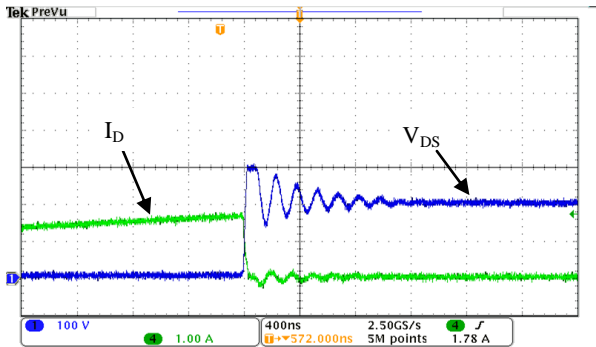

Figure 15. Enlarged View of Figure 14

Figure 16 shows the clamp snubber circuit using the SARS01/05. The surge voltage at tuning off a power MOSFET is charged to C_S through the surge absorb loop. Since the reverse recovery time, t_{rr} , of the SARS01/05 is a relatively long period, the energy charged to C_S is discharged to the reverse direction of the surge absorb loop until C_S voltage is equal to the flyback voltage. Thus, the power supply efficiency improves.

In addition, the power supply using the SARS01/05 reduces the ringing voltage. Thus, the cross regulation of multi-outputs can be improved.

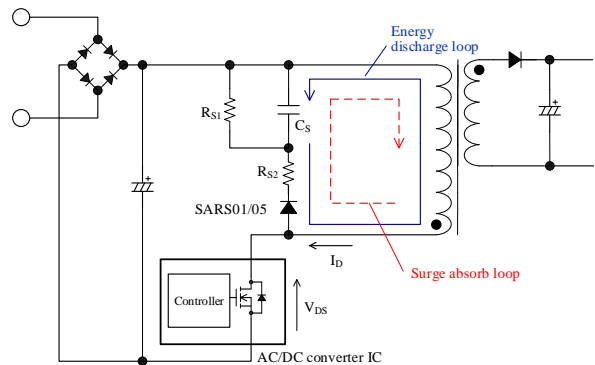

Figure 16. Clamp Snubber Circuit using SARS01/05

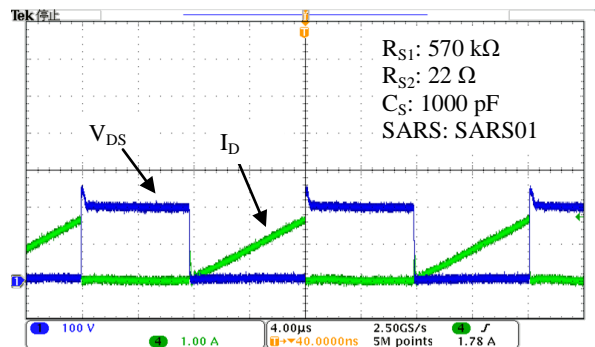

Figure 17. Waveforms of Clamp Snubber Circuit using SARS01

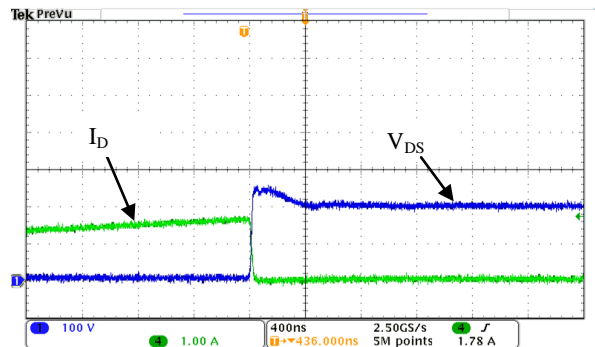

Figure 18. Enlarged View of Figure 17

Power Dissipation and Junction Temperature Calculation

Figure 19 shows a typical application using the SARS01/05. Figure 20 shows the operating waveforms of the SARS01/05. The power dissipation of the SARS01/05 is calculated as follows:

- 1) The waveforms of the SARS01/05 voltage, V_{SARS} , and the SARS01/05 current, I_{SARS} , are measured in actual application operation. $V_{SARS} \times I_{SARS}$ is calculated by the math function of oscilloscope.
- 2) The each average energy ($P_1, P_2 \dots P_k$) is measured at period of each polarity of $V_{SARS} \times I_{SARS}$ ($t_1, t_2, \dots t_k$) as shown in Figure 19 by the automatic measurement function of the oscilloscope.
- 3) The power dissipation of the SARS01/05, P_{SARS} , is calculated by Equation (1):

$$P_{SARS} = \frac{1}{T} (|P_1 \times t_1| + |P_2 \times t_2| + \dots |P_k \times t_k|) \quad (1)$$

where:

P_{SARS} is power dissipation of the SARS01/05,
 T is switching cycle of power MOSFET (s), and
 P_k is average energy of period t_k (W).

A differential probe is recommended to use for the measurement of V_{SARS} . Please conform to the oscilloscope manual about power dissipation measurement including the delay compensation of probe. In addition, by using the temperature of the SARS01/05 in actual application operation, the estimated junction temperature of the SARS01/05 is calculated by Equation (2). It should be enough lower than T_J of the absolute maximum rating.

$$T_{J(SARS)} = T_L + \theta_{J-L} \times P_{SARS} \text{ (}^\circ\text{C)} \quad (2)$$

where:

$T_{J(SARS)}$ is junction temperature of the SARS01/05,
 T_L is lead temperature of the SARS01/05, and
 θ_{J-L} is thermal resistance between junction to lead.

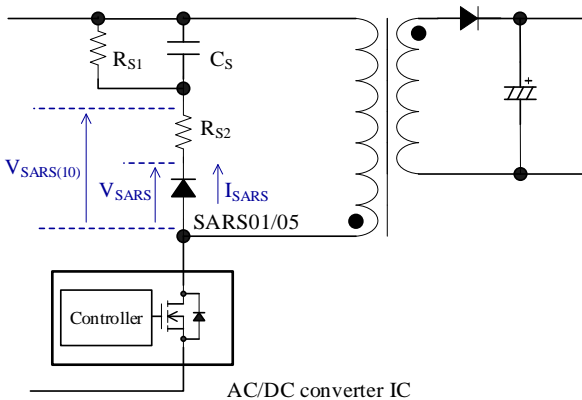

Figure 19. Typical Application

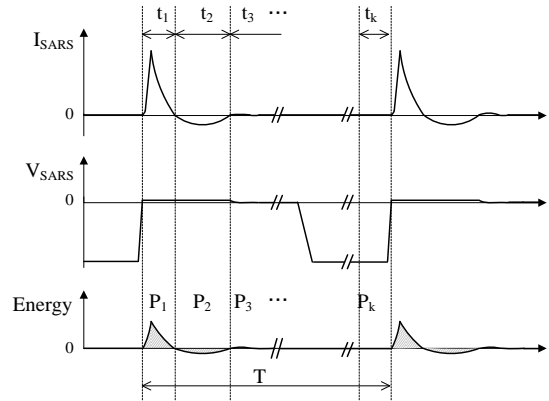

Figure 20. SARS01/05 Current

Parameter Setting of Snubber Circuit using SARS01/05

The temperature of the SARS01/05 and peripheral components should be measured in actual application operation.

The reference values of snubber circuit using the SARS01/05 are as follows:

- **C_S**
 680 pF to 0.01 μF.
 The voltage rating is selected according to the voltage subtracted the input voltage from the peak of V_{DS} .
- **R_{S1}**
 R_{S1} is the bias resistance to turn off the SARS01/05, and is 100 kΩ to 1 MΩ.
 Since a high voltage is applied to R_{S1} that has high resistance, the following should be considered according to the requirement of the application:
 - Select a resistor designed for electromigration, or
 - Connect more resistors in series so that the applied voltages of individual resistors can be reduced.
 The power rating of resistor should be selected from the measurement of the effective current of R_{S1} based on actual operation in the application.
- **R_{S2}**
 R_{S2} is the limited resistance in the energy discharging. The value of 22 Ω to 220 Ω is connected to the SARS01/05 in series.
 The power rating of resistor should be selected from the measurement of the effective current of R_{S2} based on actual operation in the application.

Reference Design of Power Supply

This section provides the information on a reference design, including power supply specifications, a circuit diagram, the bill of materials, and transformer specifications.

• Power Supply Specifications

Item	Specification
Input Voltage	85 VAC to 265 VAC
Output Power	34.8 W (40.4 W peak)
Output 1	8 V / 0.5 A
Output 2	14 V / 2.2 A (2.6 A peak)

• Circuit Schematic

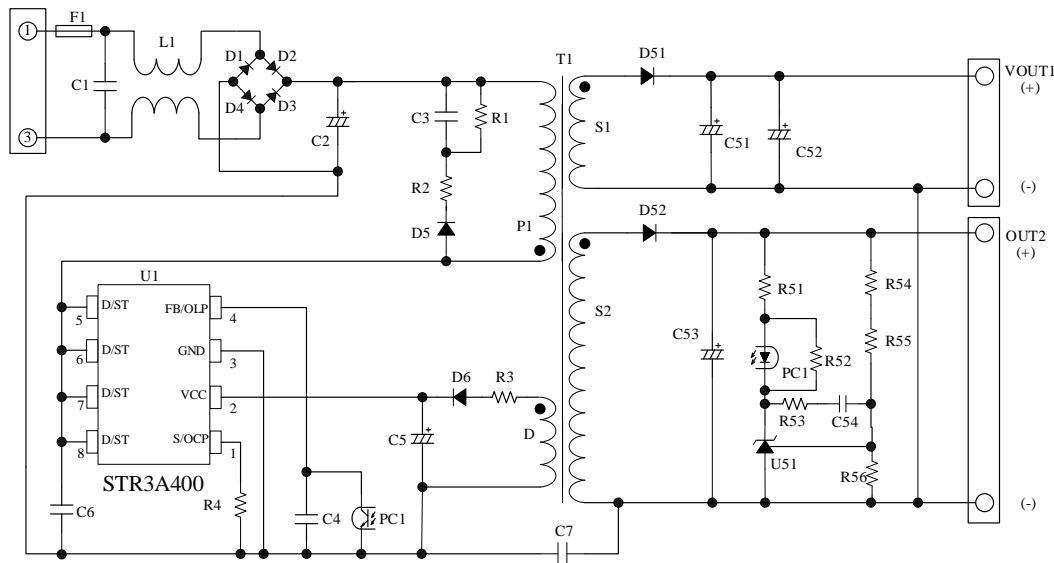

• Bill of Materials

Symbol	Ratings ⁽¹⁾	Recommended Part No.	Symbol	Ratings ⁽¹⁾	Recommended Part No.
C1 ⁽²⁾	Film, 0.1 μF, 275 V		D52	Schottky, 100 V, 10 A	SPEN-210A
C2 ⁽²⁾	Electrolytic, 150 μF, 400 V		F1	Fuse, 250 V AC, 3 A	
C3	Ceramic, 1000 pF, 1 kV		L1 ⁽²⁾	CM inductor, 3.3 mH	
C4	Ceramic, 0.01 μF		PC1	Optocoupler, PC123 or equiv.	
C5	Electrolytic, 22 μF, 50 V		R1 ⁽³⁾	Metal oxide, 330 kΩ, 1 W	
C6 ⁽²⁾	Ceramic, 15 pF / 2 kV		R2	47 Ω, 1 W	
C7 ⁽²⁾	Ceramic, 2200 pF, 250 V		R3	10 Ω	
C51 ⁽²⁾	Electrolytic, 680 μF, 25 V		R4 ⁽²⁾	0.47 Ω, 1/2 W	
C52	Electrolytic, 680 μF, 25 V		R51	1 kΩ	
C53	Electrolytic, 470 μF, 16 V		R52	1.5 kΩ	
C54 ⁽²⁾	Ceramic, 0.1 μF, 50 V		R53 ⁽²⁾	100 kΩ	
D1	600 V, 1 A	EM01A	R54 ⁽²⁾	6.8 kΩ	
D2	600 V, 1 A	EM01A	R55	± 1%, 39 kΩ	
D3	600 V, 1 A	EM01A	R56	± 1%, 10 kΩ	
D4	600 V, 1 A	EM01A	T1	See the Transformer Specification	
D5	800 V, 1.0 A	SARS05	U1	IC	STR3A453D
D6	Fast recovery, 200 V, 1.5A	SJPX-F2	U51	Shunt regulator, V _{REF} = 2.5 V	(TL431 or equiv.)
D51	Schottky, 60 V, 1.5 A	SJPW-F6			

⁽¹⁾ Unless otherwise specified, the voltage rating of capacitor is 50 V or less and the power rating of resistor is 1/8 W or less.

⁽²⁾ Refers to a part that requires adjustment based on operation performance in an actual application.

⁽³⁾ High voltage is applied to this resistor that has high resistance. To meet your application requirements, it is required to select resistors designed for electromigration, or to connect more resistors in series so that the applied voltages of individual resistors can be reduced.

SARS01, SARS05

• Transformer Specifications

Item	Specification
Primary Inductance, L_P	518 μ H
Core Size	EER-28
AL Value	245 nH/N ² (with a center gap of about 0.56 mm)
Winding Specification	See Table 1
Winding Structure	See Figure 21

Table 1. Winding Specification

Winding	Symbol	Number of Turns (turns)	Wire Diameter (mm)	Structure
Primary Winding	P1	18	ϕ 0.23 \times 2	Single-layer, solenoid winding
Primary Winding	P2	28	ϕ 0.30	Single-layer, solenoid winding
Auxiliary Winding	D	12	ϕ 0.30 \times 2	Solenoid winding
Output 1 Winding	S1-1	6	ϕ 0.4 \times 2	Solenoid winding
Output 1 Winding	S1-2	6	ϕ 0.4 \times 2	Solenoid winding
Output 2 Winding	S2-1	4	ϕ 0.4 \times 2	Solenoid winding
Output 2 Winding	S2-2	4	ϕ 0.4 \times 2	Solenoid winding

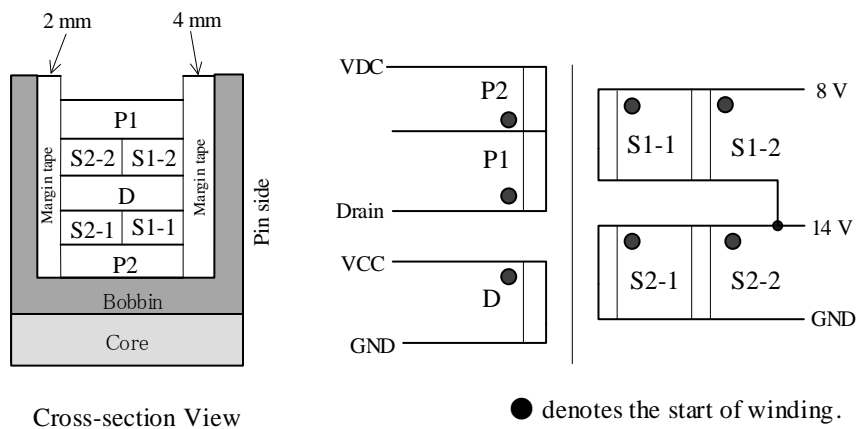

Figure 21. Winding Structure

Important Notes

- All data, illustrations, graphs, tables and any other information included in this document (the “Information”) as to Sanken’s products listed herein (the “Sanken Products”) are current as of the date this document is issued. The Information is subject to any change without notice due to improvement of the Sanken Products, etc. Please make sure to confirm with a Sanken sales representative that the contents set forth in this document reflect the latest revisions before use.
- The Sanken Products are intended for use as components of general purpose electronic equipment or apparatus (such as home appliances, office equipment, telecommunication equipment, measuring equipment, etc.). Prior to use of the Sanken Products, please put your signature, or affix your name and seal, on the specification documents of the Sanken Products and return them to Sanken. When considering use of the Sanken Products for any applications that require higher reliability (such as transportation equipment and its control systems, traffic signal control systems or equipment, disaster/crime alarm systems, various safety devices, etc.), you must contact a Sanken sales representative to discuss the suitability of such use and put your signature, or affix your name and seal, on the specification documents of the Sanken Products and return them to Sanken, prior to the use of the Sanken Products. The Sanken Products are not intended for use in any applications that require extremely high reliability such as: aerospace equipment; nuclear power control systems; and medical equipment or systems, whose failure or malfunction may result in death or serious injury to people, i.e., medical devices in Class III or a higher class as defined by relevant laws of Japan (collectively, the “Specific Applications”). Sanken assumes no liability or responsibility whatsoever for any and all damages and losses that may be suffered by you, users or any third party, resulting from the use of the Sanken Products in the Specific Applications or in manner not in compliance with the instructions set forth herein.
- In the event of using the Sanken Products by either (i) combining other products or materials or both therewith or (ii) physically, chemically or otherwise processing or treating or both the same, you must duly consider all possible risks that may result from all such uses in advance and proceed therewith at your own responsibility.
- Although Sanken is making efforts to enhance the quality and reliability of its products, it is impossible to completely avoid the occurrence of any failure or defect or both in semiconductor products at a certain rate. You must take, at your own responsibility, preventative measures including using a sufficient safety design and confirming safety of any equipment or systems in/for which the Sanken Products are used, upon due consideration of a failure occurrence rate and derating, etc., in order not to cause any human injury or death, fire accident or social harm which may result from any failure or malfunction of the Sanken Products. Please refer to the relevant specification documents and Sanken’s official website in relation to derating.
- No anti-radioactive ray design has been adopted for the Sanken Products.
- The circuit constant, operation examples, circuit examples, pattern layout examples, design examples, recommended examples, all information and evaluation results based thereon, etc., described in this document are presented for the sole purpose of reference of use of the Sanken Products.
- Sanken assumes no responsibility whatsoever for any and all damages and losses that may be suffered by you, users or any third party, or any possible infringement of any and all property rights including intellectual property rights and any other rights of you, users or any third party, resulting from the Information.
- No information in this document can be transcribed or copied or both without Sanken’s prior written consent.
- Regarding the Information, no license, express, implied or otherwise, is granted hereby under any intellectual property rights and any other rights of Sanken.
- Unless otherwise agreed in writing between Sanken and you, Sanken makes no warranty of any kind, whether express or implied, including, without limitation, any warranty (i) as to the quality or performance of the Sanken Products (such as implied warranty of merchantability, and implied warranty of fitness for a particular purpose or special environment), (ii) that any Sanken Product is delivered free of claims of third parties by way of infringement or the like, (iii) that may arise from course of performance, course of dealing or usage of trade, and (iv) as to the Information (including its accuracy, usefulness, and reliability).
- In the event of using the Sanken Products, you must use the same after carefully examining all applicable environmental laws and regulations that regulate the inclusion or use or both of any particular controlled substances, including, but not limited to, the EU RoHS Directive, so as to be in strict compliance with such applicable laws and regulations.
- You must not use the Sanken Products or the Information for the purpose of any military applications or use, including but not limited to the development of weapons of mass destruction. In the event of exporting the Sanken Products or the Information, or providing them for non-residents, you must comply with all applicable export control laws and regulations in each country including the U.S. Export Administration Regulations (EAR) and the Foreign Exchange and Foreign Trade Act of Japan, and follow the procedures required by such applicable laws and regulations.
- Sanken assumes no responsibility for any troubles, which may occur during the transportation of the Sanken Products including the falling thereof, out of Sanken’s distribution network.
- Although Sanken has prepared this document with its due care to pursue the accuracy thereof, Sanken does not warrant that it is error free and Sanken assumes no liability whatsoever for any and all damages and losses which may be suffered by you resulting from any possible errors or omissions in connection with the Information.
- Please refer to our official website in relation to general instructions and directions for using the Sanken Products, and refer to the relevant specification documents in relation to particular precautions when using the Sanken Products.
- All rights and title in and to any specific trademark or tradename belong to Sanken and such original right holder(s).

DSGN-CEZ-16003

Looking for pricing, stock, or lifecycle information?

Click below to explore more details on WIN SOURCE:

 [View SARS01V1](#) on WIN SOURCE

 [Sanken](#) Information

Optimize Your Supply Chain with WIN SOURCE Solutions

-  Global Sourcing Solution
-  Obsolete Management
-  Cost Control Management
-  Shortage Management
-  Alternative Solution
-  Excess Inventory Management