



**THE DATASHEET OF
74ABT16821ADL-T**



Important notice

Dear Customer,

On 7 February 2017 the former NXP Standard Product business became a new company with the tradename **Nexperia**. Nexperia is an industry leading supplier of Discrete, Logic and PowerMOS semiconductors with its focus on the automotive, industrial, computing, consumer and wearable application markets

In data sheets and application notes which still contain NXP or Philips Semiconductors references, use the references to Nexperia, as shown below.

Instead of <http://www.nxp.com>, <http://www.philips.com/> or <http://www.semiconductors.philips.com/>, use <http://www.nexperia.com>

Instead of sales.addresses@www.nxp.com or sales.addresses@www.semiconductors.philips.com, use salesaddresses@nexperia.com (email)

Replace the copyright notice at the bottom of each page or elsewhere in the document, depending on the version, as shown below:

- © NXP N.V. (year). All rights reserved or © Koninklijke Philips Electronics N.V. (year). All rights reserved

Should be replaced with:

- © **Nexperia B.V. (year). All rights reserved.**

If you have any questions related to the data sheet, please contact our nearest sales office via e-mail or telephone (details via salesaddresses@nexperia.com). Thank you for your cooperation and understanding,

Kind regards,

Team Nexperia

74ABT16821A

20-bit bus-interface D-type flip-flop; positive-edge trigger;
3-state

Rev. 03 — 16 March 2010

Product data sheet

1. General description

The 74ABT16821A high-performance BiCMOS device combines low static and dynamic power dissipation with high speed and high output drive.

The 74ABT16821A has two 10-bit, edge-triggered registers, with each register coupled to a 3-state output buffer. The two sections of each register are controlled independently by the clock (nCP) and output enable ($n\overline{OE}$) control gates.

Each register is fully edge triggered. The state of each D input, one set-up time before the LOW-to-HIGH clock transition, is transferred to the corresponding flip-flops Q output.

The 3-state output buffers are designed to drive heavily loaded 3-state buses, MOS memories, or MOS microprocessors.

The active-LOW output enable ($n\overline{OE}$) controls all ten 3-state buffers independent of the register operation. When $n\overline{OE}$ is LOW, the data in the register appears at the outputs. When $n\overline{OE}$ is HIGH, the outputs are in high-impedance OFF-state, which means they will neither drive nor load the bus.

2. Features and benefits

- 20-bit positive-edge triggered register
- Multiple V_{CC} and GND pins minimize switching noise
- Live insertion and extraction permitted
- Output capability: +64 mA and -32 mA
- Power-up 3-state
- Power-up reset
- Latch-up protection exceeds 500 mA per JESD78B class II level A
- ESD protection:
 - ◆ HBM JESD22-A114F exceeds 2000 V
 - ◆ MM JESD22-A115-A exceeds 200 V



3. Ordering information

Table 1. Ordering information

Type number	Package			Version
	Temperature range	Name	Description	
74ABT16821ADL	-40 °C to +85 °C	SSOP56	plastic shrink small outline package; 56 leads; body width 7.5 mm	SOT371-1
74ABT16821ADGG	-40 °C to +85 °C	TSSOP56	plastic thin shrink small outline package; 56 leads; body width 6.1 mm	SOT364-1

4. Functional diagram

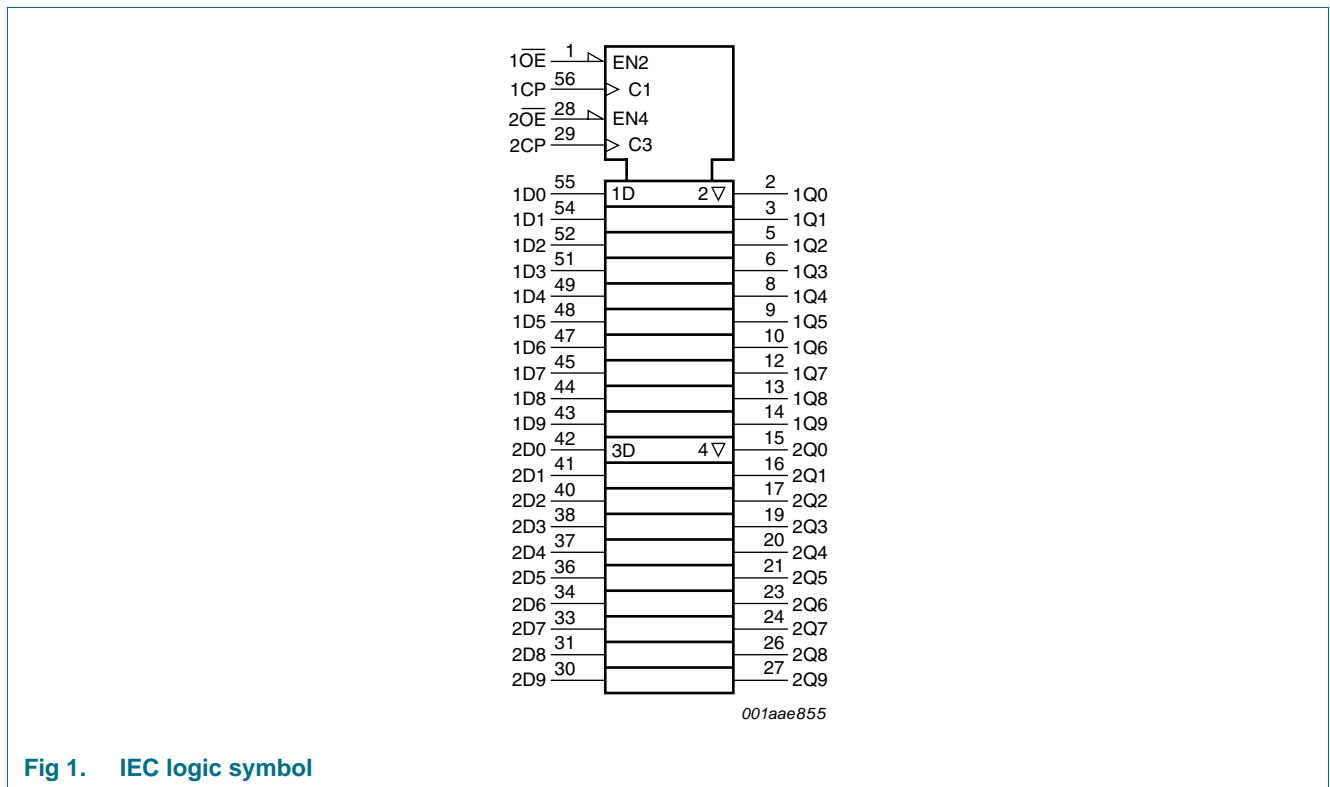

Fig 1. IEC logic symbol

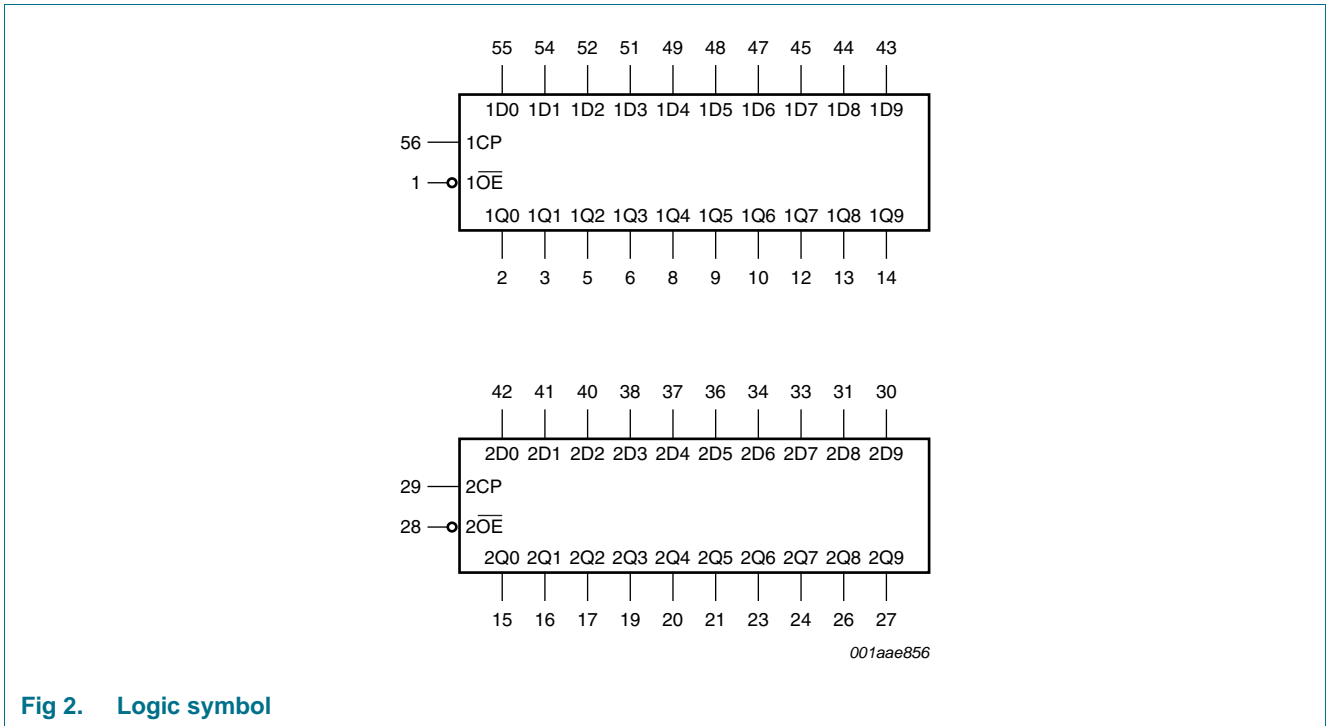

Fig 2. Logic symbol

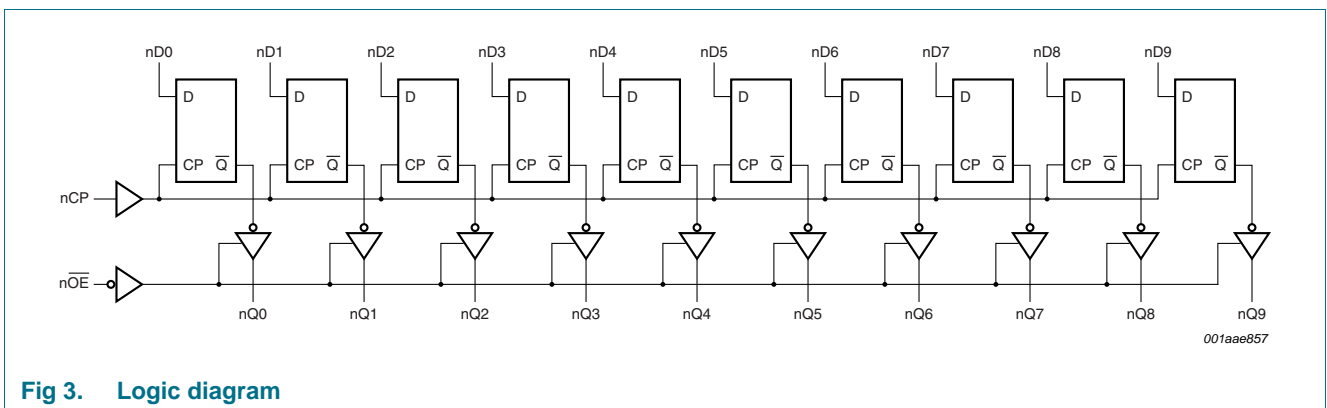

Fig 3. Logic diagram

5. Pinning information

5.1 Pinning

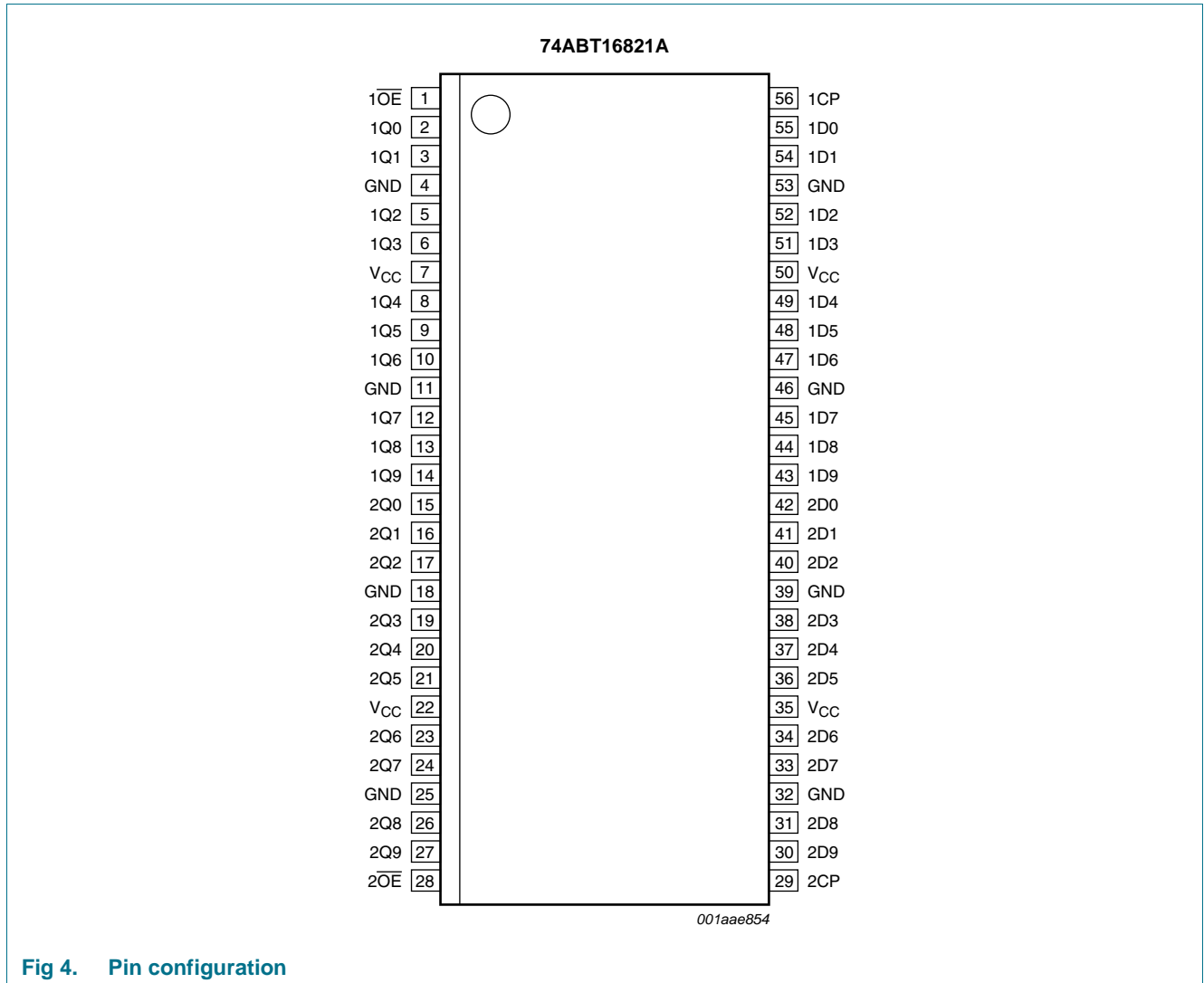

Fig 4. Pin configuration

5.2 Pin description

Table 2. Pin description

Symbol	Pin	Description
$1\overline{OE}, 2\overline{OE}$	1, 28	output enable input (active LOW)
1Q0 to 1Q9	2, 3, 5, 6, 8, 9, 10, 12, 13, 14	data output
GND	4, 11, 18, 25, 32, 39, 46, 53	ground (0 V)
V _{CC}	7, 22, 35, 50	supply voltage
2Q0 to 2Q9	15, 16, 17, 19, 20, 21, 23, 24, 26, 27	data output
2CP, 1CP	29, 56	clock pulse input (active rising edge)
2D0 to 2D9	42, 41, 40, 38, 37, 36, 34, 33, 31, 30	data input
1D0 to 1D9	55, 54, 52, 51, 49, 48, 47, 45, 44, 43	data input

6. Functional description

Table 3. Function table^[1]

Input			Output	Internal register	Operating mode
nOE	nCP	nDx	nQ0 to nQ9		
L	↑	l	L	L	load + read register
L	↑	h	H	H	load + read register
L	H or L	X	NC	NC	hold
H	L or H	X	Z	NC	disable output
H	↑	Dn	Z	Dn	disable output

- [1] H = HIGH voltage level;
 h = HIGH voltage level one set-up time prior to the LOW-to-HIGH clock transition;
 L = LOW voltage level;
 l = LOW voltage level one set-up time prior to the LOW-to-HIGH clock transition;
 ↑ = LOW-to-HIGH clock transition;
 NC = no change;
 X = don't care;
 Z = high-impedance OFF-state.

7. Limiting values

Table 4. Limiting values

In accordance with the Absolute Maximum Rating System (IEC 60134).

Symbol	Parameter	Conditions	Min	Max	Unit
V_{CC}	supply voltage		-0.5	+7.0	V
V_I	input voltage		[1] -1.2	+7.0	V
V_O	output voltage	output in OFF-state or HIGH-state	[1] -0.5	+5.5	V
I_{IK}	input clamping current	$V_I < 0$ V	-18	-	mA
I_{OK}	output clamping current	$V_O < 0$ V	-50	-	mA
I_O	output current	output in LOW-state	-	128	mA
		output in HIGH-state	-64	-	mA
T_j	junction temperature		[2] -	150	°C
T_{stg}	storage temperature		-65	+150	°C

[1] The input and output voltage ratings may be exceeded if the input and output current ratings are observed.

[2] The performance capability of a high-performance integrated circuit in conjunction with its thermal environment can create junction temperatures which are detrimental to reliability. The maximum junction temperature of this integrated circuit should not exceed 150 °C.

8. Recommended operating conditions

Table 5. Operating conditions

Voltages are referenced to GND (ground = 0 V).

Symbol	Parameter	Conditions	Min	Typ	Max	Unit
V_{CC}	supply voltage		4.5	-	5.5	V
V_I	input voltage		0	-	V_{CC}	V
V_{IH}	HIGH-level input voltage		2.0	-	-	V
V_{IL}	LOW-level Input voltage		-	-	0.8	V
I_{OH}	HIGH-level output current		-32	-	-	mA
I_{OL}	LOW-level output current		-	-	64	mA
$\Delta t/\Delta V$	input transition rise and fall rate		0	-	10	ns/V
T_{amb}	ambient temperature	in free air	-40	-	+85	°C

9. Static characteristics

Table 6. Static characteristics

Symbol	Parameter	Conditions	25 °C			-40 °C to +85 °C		Unit	
			Min	Typ	Max	Min	Max		
V_{IK}	input clamping voltage	$V_{CC} = 4.5\text{ V}$; $I_{IK} = -18\text{ mA}$	-1.2	-0.9	-	-1.2	-	V	
V_{OH}	HIGH-level output voltage	$V_I = V_{IL}$ or V_{IH}							
		$V_{CC} = 4.5\text{ V}$; $I_{OH} = -3\text{ mA}$	2.5	2.9	-	2.5	-	V	
		$V_{CC} = 5.0\text{ V}$; $I_{OH} = -3\text{ mA}$	3.0	3.4	-	3.0	-	V	
		$V_{CC} = 4.5\text{ V}$; $I_{OH} = -32\text{ mA}$	2.0	2.4	-	2.0	-	V	
V_{OL}	LOW-level output voltage	$V_{CC} = 4.5\text{ V}$; $I_{OL} = 64\text{ mA}$; $V_I = V_{IL}$ or V_{IH}	-	0.36	0.55	-	0.55	V	
$V_{OL(pu)}$	power-up LOW-level output voltage	$V_{CC} = 5.5\text{ V}$; $I_O = 1\text{ mA}$; $V_I = \text{GND}$ or V_{CC}	[1]	-	0.13	0.55	-	0.55	V
I_I	input leakage current	$V_{CC} = 5.5\text{ V}$; $V_I = V_{CC}$ or GND	-	± 0.01	± 1.0	-	± 1.0	μA	
I_{OFF}	power-off leakage current	$V_{CC} = 0\text{ V}$; V_I or $V_O \leq 4.5\text{ V}$	-	± 5.0	± 100	-	± 100	μA	
$I_{O(pu/pd)}$	power-up/power-down output current	$V_{CC} = 2.1\text{ V}$; $V_O = 0.5\text{ V}$; $V_I = \text{GND}$ or V_{CC} ; nOE don't care	[2]	-	± 5.0	± 50	-	± 50	μA
I_{OZ}	OFF-state output current	$V_{CC} = 5.5\text{ V}$; $V_I = V_{IL}$ or V_{IH}							
		output HIGH-state at $V_O = 2.7\text{ V}$	-	1.0	10	-	10	μA	
		output LOW-state at $V_O = 0.5\text{ V}$	-	-1.0	-10	-	-10	μA	
I_{LO}	output leakage current	HIGH-state; $V_O = 5.5\text{ V}$; $V_{CC} = 5.5\text{ V}$; $V_I = \text{GND}$ or V_{CC}	-	5.0	50	-	50	μA	
I_O	output current	$V_{CC} = 5.5\text{ V}$; $V_O = 2.5\text{ V}$	[3]	-180	-90	-50	-180	-50	mA
I_{CC}	supply current	$V_{CC} = 5.5\text{ V}$; $V_I = \text{GND}$ or V_{CC}							
		outputs HIGH-state	-	0.5	1.0	-	1.0	mA	
		outputs LOW-state	-	10	19	-	19	mA	
		outputs 3-state	-	0.5	1.0	-	1.0	mA	
ΔI_{CC}	additional supply current	per input pin; $V_{CC} = 5.5\text{ V}$; one input at 3.4 V and other inputs at V_{CC} or GND	[4]	-	0.25	1.5	-	1.5	mA
C_I	input capacitance	$V_I = 0\text{ V}$ or V_{CC}	-	3	-	-	-		
C_O	output capacitance	outputs disabled; $V_O = 0\text{ V}$ or V_{CC}	-	7	-	-	-		

[1] For valid test results, data must not be loaded into the flip-flops (or latches) after applying the power.

[2] This parameter is valid for any V_{CC} between 0 V and 2.1 V, with a transition time of up to 10 ms. From $V_{CC} = 2.1\text{ V}$ to $V_{CC} = 5\text{ V} \pm 10\%$ a transition time of up to 100 μs is permitted.

[3] Not more than one output should be tested at a time, and the duration of the test should not exceed one second.

[4] This is the increase in supply current for each input at 3.4 V.

10. Dynamic characteristics

Table 7. Dynamic characteristics

$GND = 0\text{ V}$; for test circuit, see [Figure 8](#).

Symbol	Parameter	Conditions	25 °C; $V_{CC} = 5.0\text{ V}$			–40 °C to +85 °C; $V_{CC} = 5.0\text{ V} \pm 0.5\text{ V}$		Unit
			Min	Typ	Max	Min	Max	
f_{\max}	maximum frequency	see Figure 5	160	250	-	160	-	MHz
t_{PLH}	LOW to HIGH propagation delay	nCP to nQx, see Figure 5	1.3	2.4	3.3	1.3	3.7	ns
t_{PHL}	HIGH to LOW propagation delay	nCP to nQx, see Figure 5	1.1	2.0	2.6	1.1	3.0	ns
t_{PZH}	OFF-state to HIGH propagation delay	$\overline{\text{nOE}}$ to nQx; see Figure 6	1.4	2.5	3.3	1.4	4.1	ns
t_{PZL}	OFF-state to LOW propagation delay	$\overline{\text{nOE}}$ to nQx; see Figure 6	1.2	2.3	3.0	1.2	3.7	ns
t_{PHZ}	HIGH to OFF-state propagation delay	$\overline{\text{nOE}}$ to nQx; see Figure 6	1.6	3.2	4.1	1.6	4.8	ns
t_{PLZ}	LOW to OFF-state propagation delay	$\overline{\text{nOE}}$ to nQx; see Figure 6	1.3	2.3	3.1	1.3	3.3	ns
$t_{su(H)}$	set-up time HIGH	nDx to nCP; see Figure 7	1.8	1.2	-	1.8	-	ns
$t_{su(L)}$	set-up time LOW	nDx to nCP; see Figure 7	+1.8	-0.9	-	+1.8	-	ns
$t_{h(H)}$	hold time HIGH	nDx to nCP; see Figure 7	1.0	0.8	-	1.0	-	ns
$t_{h(L)}$	hold time LOW	nDx to nCP; see Figure 7	+1.0	-1.0	-	+1.0	-	ns
t_{WH}	pulse width HIGH	nCP; see Figure 5	2.5	0.8	-	2.5	-	ns
t_{WL}	pulse width LOW	nCP; see Figure 5	2.5	1.0	-	2.5	-	ns

11. Waveforms

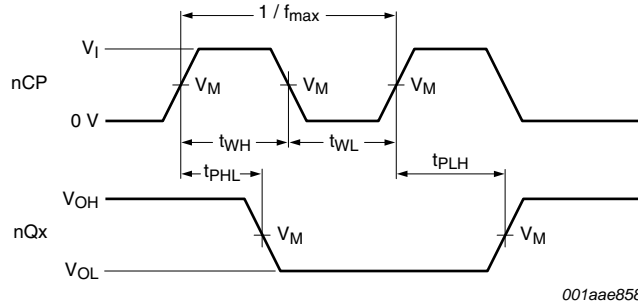

$V_M = 1.5\text{ V}$
 V_{OL} and V_{OH} are typical voltage output levels that occur with the output load.

Fig 5. Propagation delay, clock input to output, clock pulse width, and maximum clock frequency

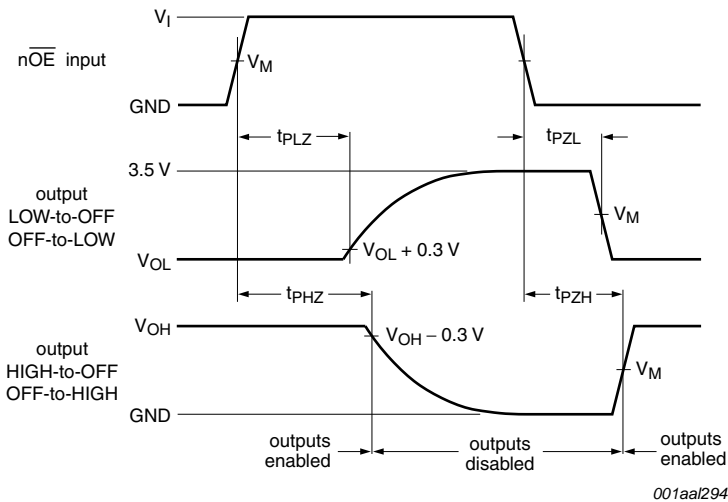

$V_M = 1.5\text{ V}$
 V_{OL} and V_{OH} are typical voltage output levels that occur with the output load.

Fig 6. 3-state output enable time to HIGH-level and output disable time from HIGH-level

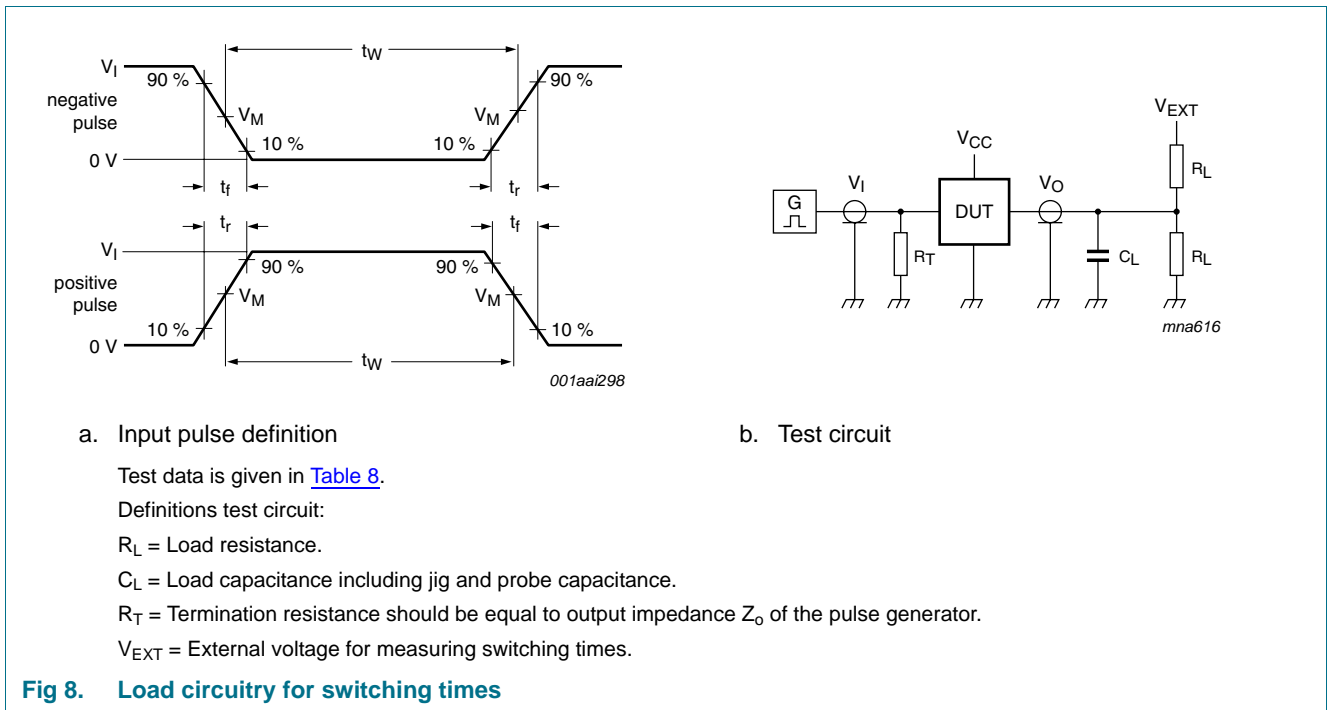
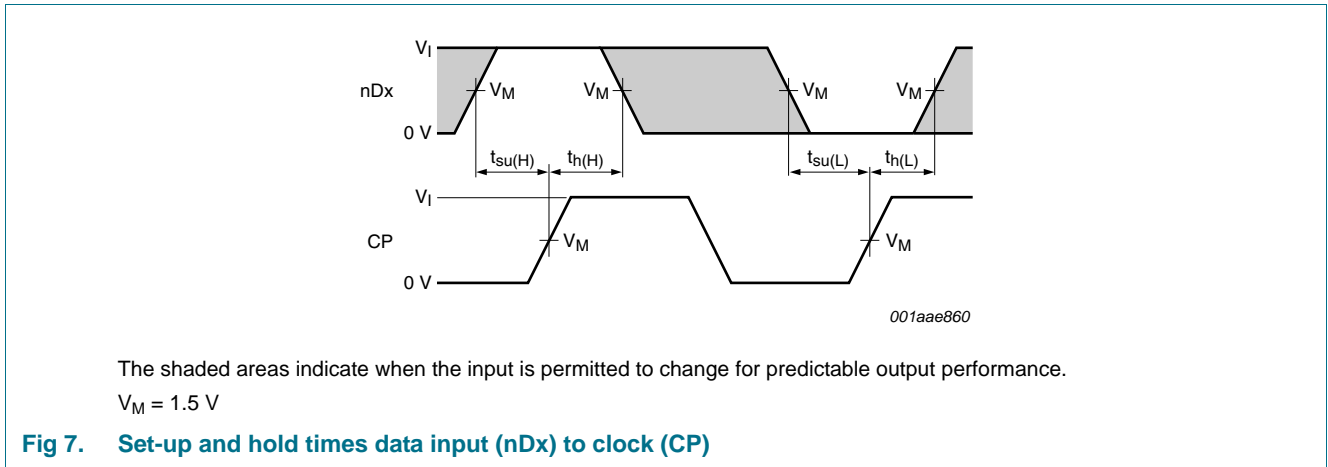

Table 8. Test data

Input				Load		V_{EXT}		
V_I	f_I	t_w	t_r, t_f	C_L	R_L	t_{PHL}, t_{PLH}	t_{PZH}, t_{PHZ}	t_{PZL}, t_{PLZ}
3.0 V	1 MHz	500 ns	$\leq 2.5\text{ ns}$	50 pF	500 Ω	open	open	7.0 V

12. Package outline

SSOP56: plastic shrink small outline package; 56 leads; body width 7.5 mm

SOT371-1

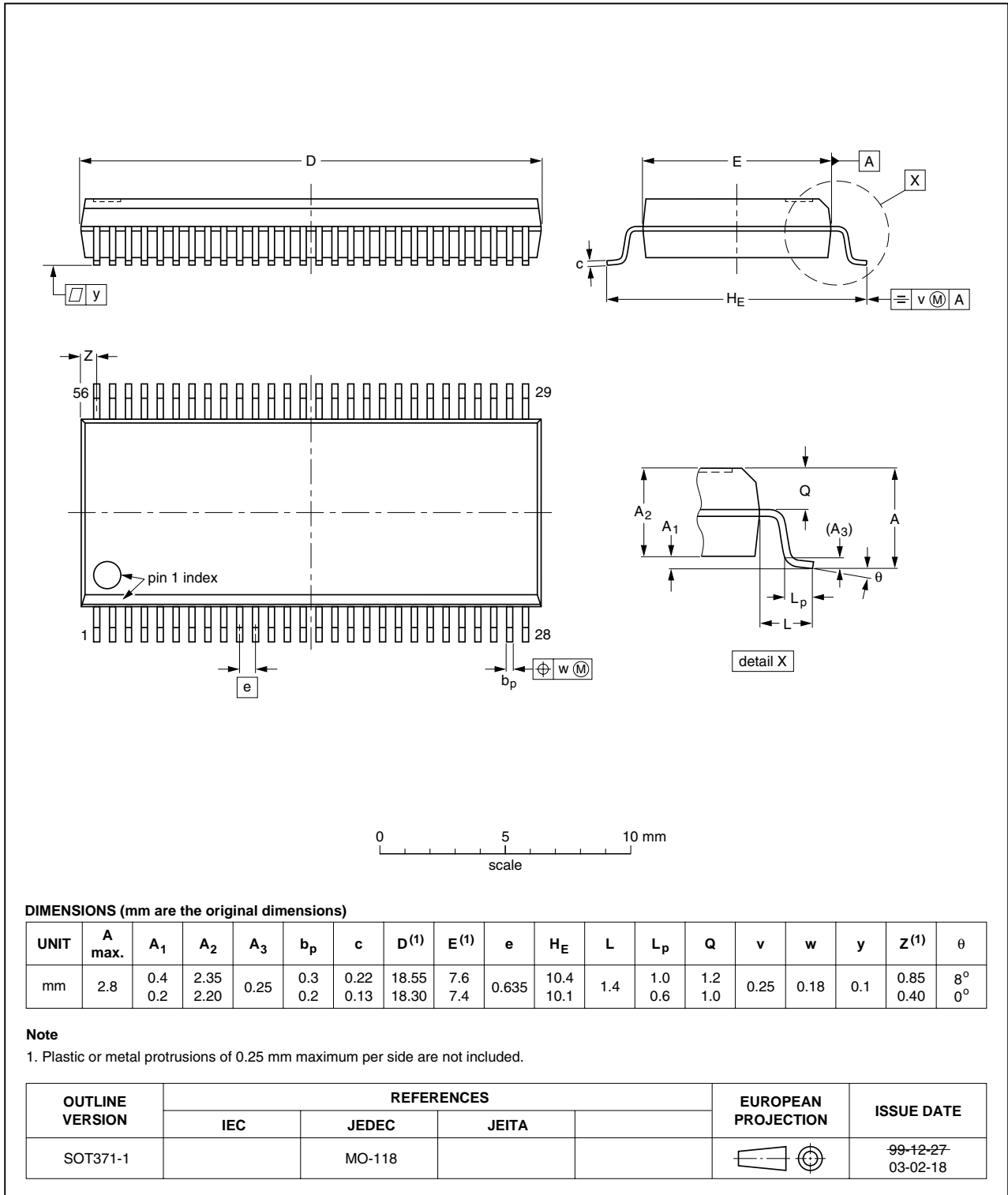

Fig 9. Package outline SOT371-1 (SSOP56)

TSSOP56: plastic thin shrink small outline package; 56 leads; body width 6.1 mm

SOT364-1

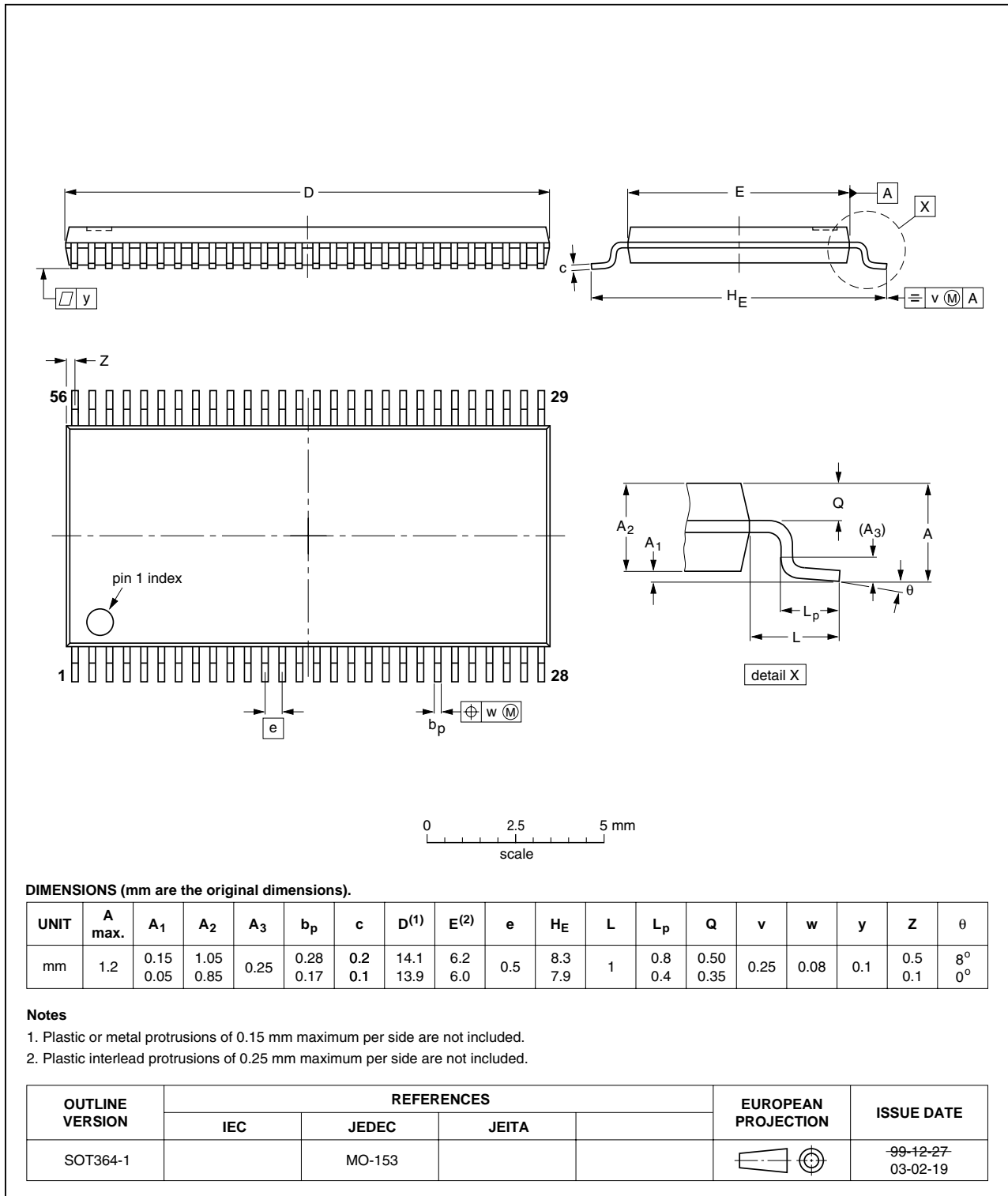

Fig 10. Package outline SOT364-1 (TSSOP56)

13. Abbreviations

Table 9. Abbreviations

Acronym	Description
BiCMOS	Bipolar Complementary Metal-Oxide Semiconductor
DUT	Device Under Test
ESD	ElectroStatic Discharge
HBM	Human Body Model
MM	Machine Model

14. Revision history

Table 10. Revision history

Document ID	Release date	Data sheet status	Change notice	Supersedes
74ABT16821A_3	20100316	Product data sheet	-	74ABT_H16821A_2
Modifications:	<ul style="list-style-type: none"> The format of this data sheet has been redesigned to comply with the new identity guidelines of NXP Semiconductors. Legal texts have been adapted to the new company name where appropriate. Type number 74ABTH16821ADGG removed from Section 3 "Ordering information". 			
74ABT_H16821A_2	20021213	Product specification	-	74ABT_H16821A
74ABT_H16821A	19980227	Product specification	-	-

15. Legal information

15.1 Data sheet status

Document status ^{[1][2]}	Product status ^[3]	Definition
Objective [short] data sheet	Development	This document contains data from the objective specification for product development.
Preliminary [short] data sheet	Qualification	This document contains data from the preliminary specification.
Product [short] data sheet	Production	This document contains the product specification.

[1] Please consult the most recently issued document before initiating or completing a design.

[2] The term 'short data sheet' is explained in section "Definitions".

[3] The product status of device(s) described in this document may have changed since this document was published and may differ in case of multiple devices. The latest product status information is available on the Internet at URL <http://www.nxp.com>.

15.2 Definitions

Draft — The document is a draft version only. The content is still under internal review and subject to formal approval, which may result in modifications or additions. NXP Semiconductors does not give any representations or warranties as to the accuracy or completeness of information included herein and shall have no liability for the consequences of use of such information.

Short data sheet — A short data sheet is an extract from a full data sheet with the same product type number(s) and title. A short data sheet is intended for quick reference only and should not be relied upon to contain detailed and full information. For detailed and full information see the relevant full data sheet, which is available on request via the local NXP Semiconductors sales office. In case of any inconsistency or conflict with the short data sheet, the full data sheet shall prevail.

Product specification — The information and data provided in a Product data sheet shall define the specification of the product as agreed between NXP Semiconductors and its customer, unless NXP Semiconductors and customer have explicitly agreed otherwise in writing. In no event however, shall an agreement be valid in which the NXP Semiconductors product is deemed to offer functions and qualities beyond those described in the Product data sheet.

15.3 Disclaimers

Limited warranty and liability — Information in this document is believed to be accurate and reliable. However, NXP Semiconductors does not give any representations or warranties, expressed or implied, as to the accuracy or completeness of such information and shall have no liability for the consequences of use of such information.

In no event shall NXP Semiconductors be liable for any indirect, incidental, punitive, special or consequential damages (including - without limitation - lost profits, lost savings, business interruption, costs related to the removal or replacement of any products or rework charges) whether or not such damages are based on tort (including negligence), warranty, breach of contract or any other legal theory.

Notwithstanding any damages that customer might incur for any reason whatsoever, NXP Semiconductors' aggregate and cumulative liability towards customer for the products described herein shall be limited in accordance with the *Terms and conditions of commercial sale* of NXP Semiconductors.

Right to make changes — NXP Semiconductors reserves the right to make changes to information published in this document, including without limitation specifications and product descriptions, at any time and without notice. This document supersedes and replaces all information supplied prior to the publication hereof.

Suitability for use in automotive applications — This NXP Semiconductors product has been qualified for use in automotive applications. The product is not designed, authorized or warranted to be

suitable for use in medical, military, aircraft, space or life support equipment, nor in applications where failure or malfunction of an NXP Semiconductors product can reasonably be expected to result in personal injury, death or severe property or environmental damage. NXP Semiconductors accepts no liability for inclusion and/or use of NXP Semiconductors products in such equipment or applications and therefore such inclusion and/or use is at the customer's own risk.

Applications — Applications that are described herein for any of these products are for illustrative purposes only. NXP Semiconductors makes no representation or warranty that such applications will be suitable for the specified use without further testing or modification.

NXP Semiconductors does not accept any liability related to any default, damage, costs or problem which is based on a weakness or default in the customer application/use or the application/use of customer's third party customer(s) (hereinafter both referred to as "Application"). It is customer's sole responsibility to check whether the NXP Semiconductors product is suitable and fit for the Application planned. Customer has to do all necessary testing for the Application in order to avoid a default of the Application and the product. NXP Semiconductors does not accept any liability in this respect.

Limiting values — Stress above one or more limiting values (as defined in the Absolute Maximum Ratings System of IEC 60134) will cause permanent damage to the device. Limiting values are stress ratings only and (proper) operation of the device at these or any other conditions above those given in the Recommended operating conditions section (if present) or the Characteristics sections of this document is not warranted. Constant or repeated exposure to limiting values will permanently and irreversibly affect the quality and reliability of the device.

Terms and conditions of commercial sale — NXP Semiconductors products are sold subject to the general terms and conditions of commercial sale, as published at <http://www.nxp.com/profile/terms>, unless otherwise agreed in a valid written individual agreement. In case an individual agreement is concluded only the terms and conditions of the respective agreement shall apply. NXP Semiconductors hereby expressly objects to applying the customer's general terms and conditions with regard to the purchase of NXP Semiconductors products by customer.

No offer to sell or license — Nothing in this document may be interpreted or construed as an offer to sell products that is open for acceptance or the grant, conveyance or implication of any license under any copyrights, patents or other industrial or intellectual property rights.

Export control — This document as well as the item(s) described herein may be subject to export control regulations. Export might require a prior authorization from national authorities.

15.4 Trademarks

Notice: All referenced brands, product names, service names and trademarks are the property of their respective owners.

16. Contact information

For more information, please visit: <http://www.nxp.com>

For sales office addresses, please send an email to: salesaddresses@nxp.com

17. Contents

1	General description	1
2	Features and benefits	1
3	Ordering information	2
4	Functional diagram	2
5	Pinning information	4
5.1	Pinning	4
5.2	Pin description	5
6	Functional description	5
7	Limiting values	6
8	Recommended operating conditions	6
9	Static characteristics	7
10	Dynamic characteristics	8
11	Waveforms	9
12	Package outline	11
13	Abbreviations	13
14	Revision history	13
15	Legal information	14
15.1	Data sheet status	14
15.2	Definitions	14
15.3	Disclaimers	14
15.4	Trademarks	14
16	Contact information	15
17	Contents	16

Please be aware that important notices concerning this document and the product(s) described herein, have been included in section 'Legal information'.

© NXP B.V. 2010.

All rights reserved.

For more information, please visit: <http://www.nxp.com>

For sales office addresses, please send an email to: salesaddresses@nxp.com

Date of release: 16 March 2010

Document identifier: 74ABT16821A_3

Looking for pricing, stock, or lifecycle information?

Click below to explore more details on WIN SOURCE:

- [View 74ABT16821ADL-T on WIN SOURCE](#)
- [NXP / Nexperia Information](#)

Optimize Your Supply Chain with WIN SOURCE Solutions

- ✓ Global Sourcing Solution
- ✓ Obsolete Management
- ✓ Cost Control Management
- ✓ Shortage Management
- ✓ Alternative Solution
- ✓ Excess Inventory Management