



**THE DATASHEET OF
73S8024RN-20IM/F**





73S8024RN

Low-Cost Smart Card Interface

DATA SHEET



DESCRIPTION

The 73S8024RN is a single smart card (ICC) interface IC that can be controlled by a dedicated control bus. The 73S8024RN has been designed to provide full electrical compliance with ISO 7816-3, EMV 4.0 (EMV2000) and NDS specifications.

Interfacing with the system controller is done through a control bus, composed of digital inputs to control the interface, and one interrupt output to inform the system controller of the card presence and faults.

The card clock can be generated by an on-chip oscillator using an external crystal or by connection to a clock signal.

The 73S8024RN incorporates an ISO 7816-3 activation/deactivation sequencer that controls the card signals. Level-shifters drive the card signals with the selected card voltage (3V or 5V), coming from an internal Low Drop-Out (LDO) voltage regulator. This LDO regulator is powered by a dedicated power supply input V_{PC} . Digital circuitry is separately powered by a digital power supply V_{DD} .

With its embedded LDO regulator, the 73S8024RN is a cost effective solution for any application where a 5V (typically -5% +10%) power supply is available. Hardware support for auxiliary I/O lines, C4 / C8 contacts, is provided*.

Emergency card deactivation is initiated upon card extraction or upon any fault generated by the protection circuitry. The fault can be a card over-current, a V_{DD} (digital power supply)**, a V_{PC} (regulator power supply), a V_{CC} (card power supply) or an over-heating fault.

The card over-current circuitry is a true current detection function, as opposed to V_{CC} voltage drop detection, as usually implemented in ICC interface ICs.

The V_{DD} voltage fault has a threshold voltage that can be adjusted with an external resistor or resistor network. It allows automated card deactivation at a customized V_{DD} voltage threshold value. It can be used, for instance, to match the system controller operating voltage range.

APPLICATIONS

- **Set-Top-Box Conditional Access and Pay-per-View**
- **Point of Sales and Transaction Terminals**
- **Control Access and Identification**

* Pins/functions not available on 20-pin QFN package.

** User V_{DD_FLT} threshold configuration not available on 20-pin QFN package.

ADVANTAGES

- **Traditional step-up converter is replaced by a LDO regulator:**
 - Greatly reduced power dissipation
 - Fewer external components are required
 - Better noise performance
 - High current capability (90mA supplied to the card)
- **SO28 package is pin-to-pin compatible with industry-standard TDA8004 and TDA8024**
- **Card clock STOP (high and low) mode**
- **Small format (4x4x0.85mm) 20QFN package option**
- **True card over-current detection**

FEATURES

- **Card Interface:**
 - Complies with ISO 7816-3, EMV 4.0, and NDS
 - An LDO voltage regulator provides 3V / 5V to the card from an external power supply input
 - Provides at least 90mA to the card
 - ISO 7816-3 Activation / Deactivation sequencer with emergency automated deactivation on card removal or fault detected by the protection circuitry
 - Protection includes 3 voltage supervisors that detect voltage drops on V_{CC} (card), V_{DD} (digital)**, and V_{PC} (regulator) power supplies
 - The V_{DD} voltage supervisor threshold value can be externally adjusted**
 - Over-current detection 150mA max
 - Card clock stop high or low*
 - 2 card detection inputs, 1 for each possible user polarity
 - Auxiliary I/O lines, for C4 / C8 contact signals*
 - Card CLK clock frequency up to 20MHz
- **System Controller Interface:**
 - 3 Digital inputs control the card activation / deactivation, card reset and card voltage
 - 4 Digital inputs control the card clock (division rate and card clock stop modes)
 - 1 Digital output, interrupt to the system controller, allows the system controller to monitor the card presence and faults.
 - Crystal oscillator or host clock, up to 27MHz
- **Regulator Power Supply:**
 - 4.75V to 5.5V (EMV 4.0)
 - 4.85V to 5.5V (NDS)
- **Digital Interfacing: 2.7V to 5.5V**
- **±6kV ESD Protection on the card interface**
- **Package: SO28, 20QFN or 32QFN**

FUNCTIONAL DIAGRAM

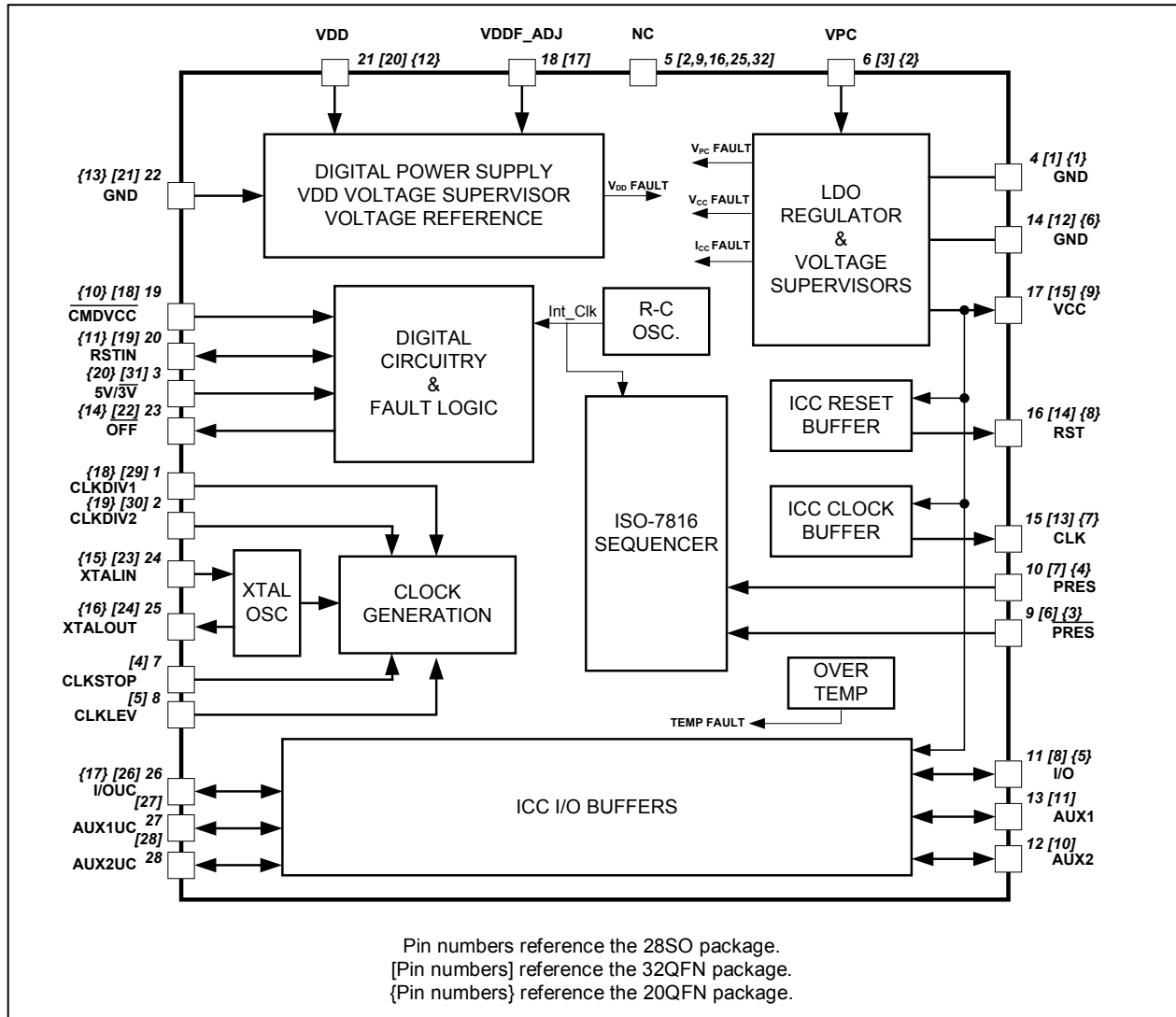

Figure 1: 73S8024RN Block Diagram

Table of Contents

| | | |
|-----------|---|-----------|
| 1 | Pin Description | 5 |
| 2 | System Controller Interface | 7 |
| 3 | Power Supply and Voltage Supervision | 8 |
| 4 | Card Power Supply | 9 |
| 5 | Over-Temperature Monitor | 9 |
| 6 | On-Chip Oscillator and Card Clock | 9 |
| 7 | Activation Sequence | 10 |
| 8 | Deactivation Sequence | 12 |
| 9 | $\overline{\text{OFF}}$ and Fault Detection | 13 |
| 10 | I/O Circuitry and Timing | 13 |
| 11 | Typical Application Schematic | 15 |
| 12 | Electrical Specification | 16 |
| | 12.1 Absolute Maximum Ratings | 16 |
| | 12.2 Recommended Operating Conditions | 16 |
| | 12.3 Package Thermal Parameters | 16 |
| | 12.4 Smart Card Interface Requirements..... | 17 |
| | 12.5 Characteristics: Digital Signals..... | 19 |
| | 12.6 DC Characteristics..... | 20 |
| | 12.7 Voltage / Temperature Fault Detection Circuits | 20 |
| 13 | Mechanical Drawing (20QFN) | 21 |
| 14 | Package Pin Designation (20QFN) | 22 |
| 15 | Mechanical Drawing (32QFN) | 23 |
| 16 | Package Pin Designation (32QFN) | 24 |
| 17 | Mechanical Drawing (SO) | 25 |
| 18 | Package Pin Designation (SO) | 25 |
| 19 | Ordering Information | 26 |
| 20 | Related Documentation | 26 |
| 21 | Contact Information | 26 |
| | Revision History | 27 |

Figures

| | |
|--|----|
| Figure 1: 73S8024RN Block Diagram | 2 |
| Figure 2: Activation Sequence – RSTIN Low When $\overline{\text{CMDVCC}}$ Goes Low | 10 |
| Figure 3: Activation Sequence – RSTIN High When $\overline{\text{CMDVCCB}}$ Goes Low | 11 |
| Figure 4: Deactivation Sequence..... | 12 |
| Figure 5: Timing Diagram – Management of the Interrupt Line $\overline{\text{OFF}}$ | 13 |
| Figure 6: I/O and I/OUC State Diagram | 14 |
| Figure 7: I/O – I/OUC Delays Timing Diagram | 14 |
| Figure 8: 73S8024RN – Typical Application Schematic..... | 15 |
| Figure 9: 20QFN Mechanical Drawing | 21 |
| Figure 10: 20QFN Pin Out..... | 22 |
| Figure 11: 32QFN Mechanical Drawing | 23 |
| Figure 12: 32QFN Pin Out..... | 24 |

Tables

| | |
|--|---|
| Table 1: Choice of V_{CC} Pin Capacitor..... | 9 |
| Table 2: Card Clock Frequency | 9 |

1 Pin Description

CARD INTERFACE

| Name | Pin 28SO | Pin 20QFN | Pin 32QFN | Description |
|-------------------|-------------|--------------|--------------|--|
| I/O | 11 | 5 | 8 | Card I/O: Data signal to/from card. Includes a pull-up resistor to V_{CC} . |
| AUX1 | 13 | – | 11 | AUX1: Auxiliary data signal to/from card. Includes a pull-up resistor to V_{CC} . |
| AUX2 | 12 | – | 10 | AUX2: Auxiliary data signal to/from card. Includes a pull-up resistor to V_{CC} . |
| RST | 16 | 8 | 14 | Card reset: provides reset (RST) signal to card. |
| CLK | 15 | 7 | 13 | Card clock: provides clock signal (CLK) to card. The rate of this clock is determined by the external crystal frequency or frequency of the external clock signal applied on XTALIN and CLKDIV selections. |
| PRES | 10 | 4 | 7 | Card Presence switch: active high indicates card is present. Should be tied to GND when not used, but it includes a high-impedance pull-down current source. |
| \overline{PRES} | 9 | 3 | 6 | Card Presence switch: active low indicates card is present. Should be tied to V_{DD} when not used, but it includes a high-impedance pull-up current source. |
| VCC | 17 | 9 | 15 | Card power supply – logically controlled by sequencer, output of LDO regulator. Requires an external filter capacitor to the card GND. |
| GND | 14 | 6 | 12 | Card ground. |

MISCELLANEOUS INPUTS AND OUTPUTS

| Name | Pin 28SO | Pin 20QFN | Pin 32QFN | Description |
|----------|-------------|--------------|------------------------|---|
| XTALIN | 24 | 15 | 23 | Crystal oscillator input: can either be connected to crystal or driven as a source for the card clock. |
| XTALOUT | 25 | 16 | 24 | Crystal oscillator output: connected to crystal. Left open if XTALIN is being used as external clock input. |
| VDDF_ADJ | 18 | – | 17 | V_{DD} fault threshold adjustment input: this pin can be used to adjust the V_{DDF} values (that controls deactivation of the card). Must be left open if unused. |
| NC | 5 | – | 2, 9, 16, 25, 32 | Non-connected pin. |

POWER SUPPLY AND GROUND

| Name | Pin 28SO | Pin 20QFN | Pin 32QFN | Description |
|------|-------------|--------------|--------------|--|
| VDD | 21 | 12 | 20 | System interface supply voltage and supply voltage for internal circuitry. |
| VPC | 6 | 2 | 3 | LDO regulator power supply source. |
| GND | 4 | 1 | 1 | LDO Regulator ground. |
| GND | 22 | 13 | 21 | Digital ground. |

MICROCONTROLLER INTERFACE

| Name | Pin 28SO | Pin 20QFN | Pin 32QFN | Description | | | | | | | | | | | | | | | |
|----------------------------|-------------|--------------|--------------|---|---------|---------|------------|---|---|----------|---|---|----------|---|---|----------|---|---|--------|
| $\overline{\text{CMDVCC}}$ | 19 | 10 | 18 | Command VCC (negative assertion): Logic low on this pin causes the LDO regulator to ramp the V_{CC} supply to the card and initiates a card activation sequence, if a card is present. | | | | | | | | | | | | | | | |
| 5V/3V | 3 | 20 | 31 | 5 volt / 3 volt card selection: Logic one selects 5 volts for V_{CC} and card interface, logic low selects 3 volt operation. When the part is to be used with a single card voltage, this pin should be tied to either GND or V_{DD} . However, it includes a high impedance pull-up resistor to default this pin high (selection of 5V card) when not connected. | | | | | | | | | | | | | | | |
| CLKSTOP | 7 | – | 4 | Stops the card clock signal during a card session when set high (card clock STOP mode). Internal pull-down resistor allows this pin to be left as an open circuit if the clock STOP mode is not used. | | | | | | | | | | | | | | | |
| CLKLVL | 8 | – | 5 | Sets the logic level of the card clock STOP mode when the clock is de-activated by setting pin 7 high. Logic low selects card STOP low. Logic high selects card STOP high. Internal pull-down resistor allows this pin to be left as an open circuit if the clock STOP mode is not used. | | | | | | | | | | | | | | | |
| CLKDIV1 CLKDIV2 | 1 2 | 18 19 | 29 30 | Sets the divide ratio from the XTAL oscillator (or external clock input) to the card clock. These pins include pull-down resistors. <table style="margin-left: auto; margin-right: auto;"> <thead> <tr> <th>CLKDIV1</th> <th>CLKDIV2</th> <th>CLOCK RATE</th> </tr> </thead> <tbody> <tr> <td>0</td> <td>0</td> <td>XTALIN/8</td> </tr> <tr> <td>0</td> <td>1</td> <td>XTALIN/4</td> </tr> <tr> <td>1</td> <td>1</td> <td>XTALIN/2</td> </tr> <tr> <td>1</td> <td>0</td> <td>XTALIN</td> </tr> </tbody> </table> | CLKDIV1 | CLKDIV2 | CLOCK RATE | 0 | 0 | XTALIN/8 | 0 | 1 | XTALIN/4 | 1 | 1 | XTALIN/2 | 1 | 0 | XTALIN |
| CLKDIV1 | CLKDIV2 | CLOCK RATE | | | | | | | | | | | | | | | | | |
| 0 | 0 | XTALIN/8 | | | | | | | | | | | | | | | | | |
| 0 | 1 | XTALIN/4 | | | | | | | | | | | | | | | | | |
| 1 | 1 | XTALIN/2 | | | | | | | | | | | | | | | | | |
| 1 | 0 | XTALIN | | | | | | | | | | | | | | | | | |
| $\overline{\text{OFF}}$ | 23 | 14 | 22 | Interrupt signal to the processor. Active Low - Multi-function indicating fault conditions and card presence. Open drain output configuration. It includes an internal 21k Ω pull-up to V_{DD} . | | | | | | | | | | | | | | | |
| RSTIN | 20 | 11 | 19 | Reset Input: This signal is the reset command to the card. | | | | | | | | | | | | | | | |
| I/OUC | 26 | 17 | 26 | System controller data I/O to/from the card. Includes a pull-up resistor to V_{DD} . | | | | | | | | | | | | | | | |
| AUX1UC | 27 | – | 27 | System controller auxiliary data I/O to/from the card. Includes a pull-up resistor to V_{DD} . | | | | | | | | | | | | | | | |
| AUX2UC | 28 | – | 28 | System controller auxiliary data I/O to/from the card. Includes a pull-up resistor to V_{DD} . | | | | | | | | | | | | | | | |

2 System Controller Interface

Three separated digital inputs allow direct control of the card interface from the host as follows:

- Pin $\overline{\text{CMDVCC}}$: When low, starts an activation sequence.
- Pin RSTIN: controls the card Reset signal (when enabled by the sequencer).
- Pin $5V/\overline{3V}$: Defines the card voltage.

Card clock is controlled by four digital inputs:

- CLKDIV1 and CLKDIV2 define the division rate for the clock frequency, from the input clock frequency (crystal or external clock).
- CLKSTOP (active high) allows card power down mode by stopping the card clock.
- CLKLEV defines the card clock level of the card power down mode.

Interrupt output to the host: As long as the card is not activated, the $\overline{\text{OFF}}$ pin informs the host about the card presence only (Low = No card in the reader). When $\overline{\text{CMDVCC}}$ is set low (Card activation sequence requested from the host), low level on $\overline{\text{OFF}}$ means a fault has been detected (e.g. card removal during card session, or voltage fault, or thermal / over-current fault) that automatically initiates a deactivation sequence.

3 Power Supply and Voltage Supervision

The 73S8024RN smart card interface IC incorporates a LDO voltage regulator. The voltage output is controlled by the digital input $5V/3V$. This regulator is able to provide either 3V or 5V card voltage from the power supply applied on the VPC pin.

Digital circuitry is powered by the power supply applied on the VDD pin. V_{DD} also defines the voltage range to interface with the system controller.

Three voltage supervisors constantly check the presence of the voltages V_{DD} , V_{PC} and V_{CC} . A card deactivation sequence is forced upon fault of any of these voltage supervisors. The two voltage supervisors for V_{PC} and V_{CC} are linked so that a fault is generated to activate a deactivation sequence when the voltage V_{PC} becomes lower than V_{CC} . It allows the 73S8024RN to operate at lower V_{PC} voltage when using 3V cards only. The voltage regulator can provide a current of at least 90mA on V_{CC} that comply easily with EMV 4.0 and NDS specifications. The V_{PC} voltage supervisor threshold values are defined from applicable standards (EMV and NDS). A third voltage supervisor monitors the V_{DD} voltage. It is used to initialize the ISO 7816-3 sequencer at power-on, and to deactivate the card at power-off or upon fault. The voltage threshold of the V_{DD} voltage supervisor is internally set by default to 2.3V nominal. However, it may be desirable, in some applications, to modify this threshold value. The pin $VDDF_ADJ$ (pin 18 in the SO package, pin 17 in the 32QFN package, not supported in the 20QFN package) is used to connect an external resistor R_{EXT} to ground to raise the V_{DD} fault voltage to another value V_{DDF} . The resistor value is defined as follows:

$$R_{EXT} = 56k\Omega / (V_{DDF} - 2.33)$$

An alternative method (more accurate) of adjusting the V_{DD} fault voltage is to use a resistive network of R3 from the pin to supply and R1 from the pin to ground (see applications diagram). In order to set the new threshold voltage, the equivalent resistance must be determined. This resistance value will be designated Kx. Kx is defined as $R1/(R1+R3)$. Kx is calculated as:

$$Kx = (2.789 / V_{TH}) - 0.6125 \text{ where } V_{TH} \text{ is the desired new threshold voltage.}$$

To determine the values of R1 and R3, use the following formulas.

$$R3 = 24000 / Kx \quad R1 = R3 * (Kx / (1 - Kx))$$

Taking the example above, where a V_{DD} fault threshold voltage of 2.7V is desired, solving for Kx gives:

$$\rightarrow Kx = (2.789 / 2.7) - 0.6125 = 0.42046.$$

$$\text{Solving for R3 gives: } \rightarrow R3 = 24000 / 0.42046 = 57080.$$

$$\text{Solving for R1 gives: } \rightarrow R1 = 57080 * (0.42046 / (1 - 0.42046)) = 41412.$$

Using standard 1 % resistor values gives $R3 = 57.6K\Omega$ and $R1 = 42.4K\Omega$.

These values give an equivalent resistance of $Kx = 0.4228$, a 0.6% error.

If the 2.3V default threshold is used, this pin must be left unconnected. The 20QFN package has the V_{DD} fault threshold fixed at this default value.

4 Card Power Supply

The card power supply is internally provided by the LDO regulator, and controlled by the digital ISO 7816-3 sequencer. Card voltage selection is carried out by the digital input $5V/3V$.

Choice of the V_{CC} Capacitor:

Depending on the applications, the requirements in terms of both V_{CC} minimum voltage and transient currents that the interface must be able to provide to the card are different. An external capacitor must be connected between the VCC pin and to the card ground in order to guarantee stability of the LDO regulator, and to handle the transient requirements. The type and value of this capacitor can be optimized to meet the desired specification. Table 1 shows the recommended capacitors for each V_{PC} power supply configuration and applicable specification.

Table 1: Choice of V_{CC} Pin Capacitor

| Specification Requirements | | | System Requirements | | |
|----------------------------|---|------------------------------|------------------------------------|---|-----------------|
| Specification | Min V_{CC} Voltage Allowed During Transient Current | Max Transient Current Charge | Min V_{PC} Power Supply Required | Capacitor Type | Capacitor Value |
| EMV 4.0 | 4.6V | 30nA.s | 4.75V | X5R/X7R w/ ESR < 100m Ω | 3.3 μ F |
| ISO 7816-3 | 4.5V | 20nA.s | 4.75V | | 1 μ F |
| NDS | 4.6V | 40nA.s | 4.85V | | 1 μ F |

Note: Capacitor value for NDS implementation is also defined by the deactivation time requirement.

5 Over-Temperature Monitor

A built-in detector monitors die temperature. Upon an over-temperature condition, a card deactivation sequence is initiated, and an error or fault condition is reported to the system controller.

6 On-Chip Oscillator and Card Clock

The 73S8024RN device has an on-chip oscillator that can generate the smart card clock using an external crystal (connected between the pins XTALIN and XTALOUT) to set the oscillator frequency. When the clock signal is available from another source, it can be connected to the pin XTALIN, and the pin XTALOUT should be left unconnected.

The card clock frequency may be chosen between four different division rates, defined by digital inputs CLKDIV 1 and CLKDIV 2, as per Table 2.

Table 2: Card Clock Frequency

| CLKDIV1 | CLKDIV2 | CLK |
|---------|---------|----------------------|
| 0 | 0 | $\frac{1}{8}$ XTALIN |
| 0 | 1 | $\frac{1}{4}$ XTALIN |
| 1 | 0 | XTALIN |
| 1 | 1 | $\frac{1}{2}$ XTALIN |

Card power down mode (card clock STOP) is supported and is controllable through the dedicated digital inputs CLKSTOP and CLKLEV (not supported in the 20QFN package).

7 Activation Sequence

The 73S8024RN smart card interface IC has an internal 10ms delay at power on reset or on the application of $V_{DD} > V_{DDF}$. No activation is allowed at this time. The \overline{CMDVCC} (edge triggered) must then be set low to activate the card. In order to initiate activation, the card must be present; there can be no over-temperature fault or no V_{DD} fault.

The following steps show the activation sequence and the timing of the card control signals when the system controller sets \overline{CMDVCC} low while the $RSTIN$ is low:

- \overline{CMDVCC} is set low.
- Next, the internal V_{CC} control circuit checks the presence of V_{CC} at the end of t_1 . In normal operation, the voltage V_{CC} to the card becomes valid during t_1 . If V_{CC} does not become valid, the OFF goes low to report a fault to the system controller, and the power V_{CC} to the card is shut off.
- Turn I/O (AUX1, AUX2) to reception mode at the end of (t_2).
- CLK is applied to the card at the end of (t_3).
- RST is a copy of $RSTIN$ after (t_4). $RSTIN$ may be set high before t_4 , however the sequencer will not set RST high until 42000 clock cycles after the start of CLK.

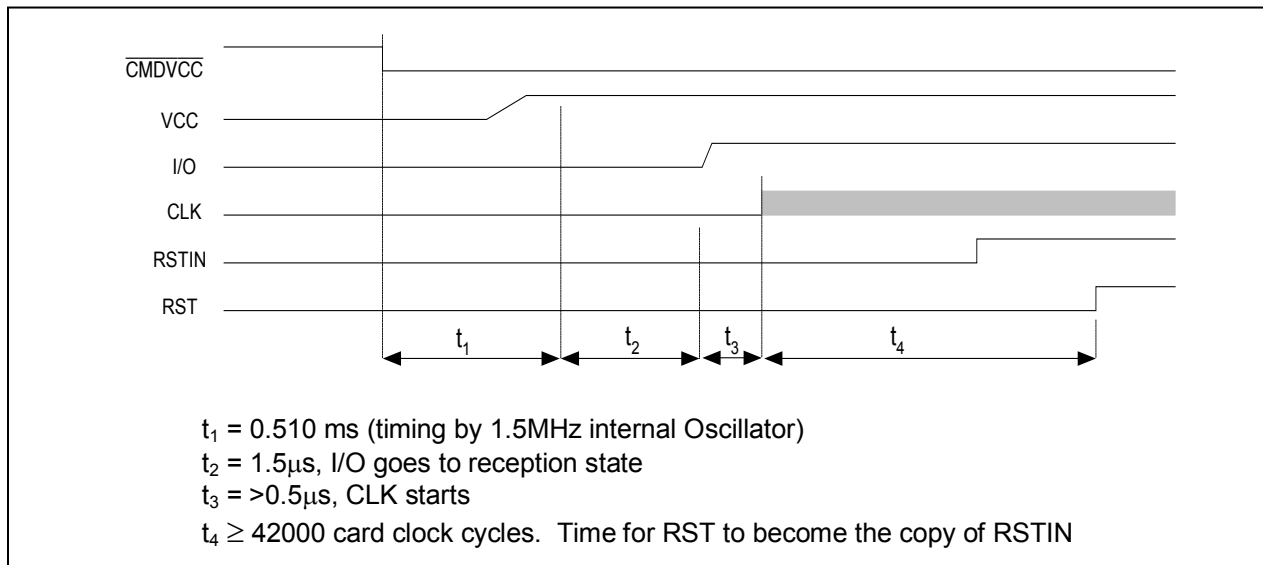

Figure 2: Activation Sequence – RSTIN Low When \overline{CMDVCC} Goes Low

The following steps show the activation sequence and the timing of the card control signals when the system controller pulls the $\overline{\text{CMDVCC}}$ low while the RSTIN is high:

- $\overline{\text{CMDVCC}}$ is set low.
- Next, the internal V_{CC} control circuit checks the presence of V_{CC} at the end of t_1 . In normal operation, the voltage V_{CC} to the card becomes valid during this time. If not, $\overline{\text{OFF}}$ goes low to report a fault to the system controller, and the power V_{CC} to the card is shut down.
- Due to the fall of RSTIN at (t_2), turn I/O (AUX1, AUX2) to reception mode.
- CLK is applied to the card at the end of (t_3), after I/O is in reception mode.
- RST is to be a copy of RSTIN after (t_4). RSTIN may be set high before t_4 , however the sequencer will not set RST high until 42000 clock cycles after the start of CLK.

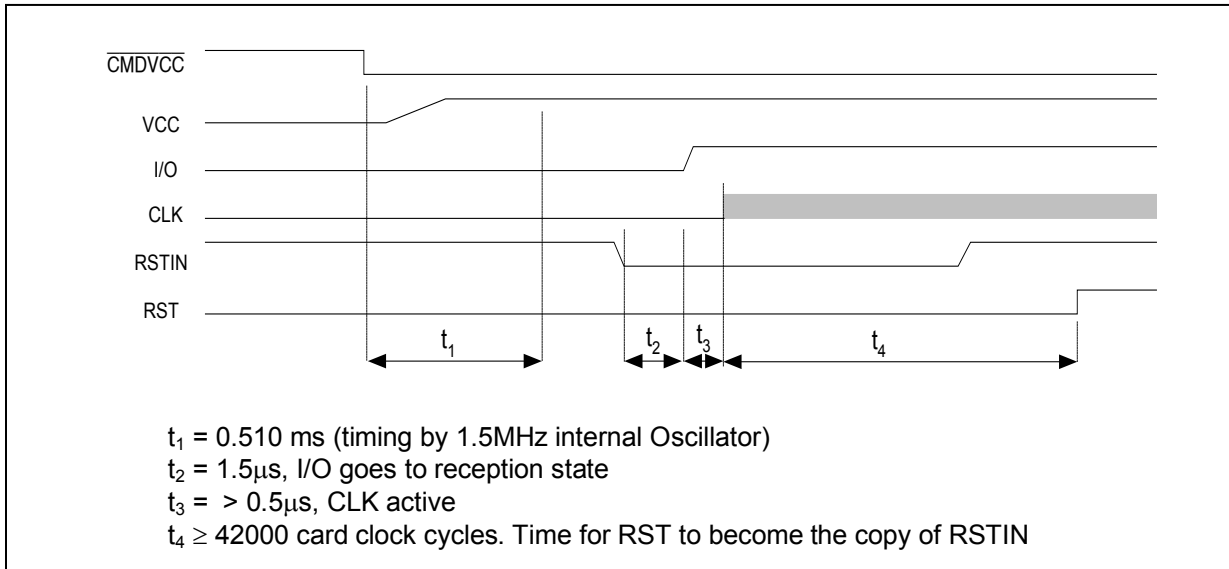

Figure 3: Activation Sequence – RSTIN High When $\overline{\text{CMDVCC}}$ Goes Low

8 Deactivation Sequence

Deactivation is initiated either by the system controller by setting the $\overline{\text{CMDVCC}}$ high, or automatically in the event of hardware faults. Hardware faults are over-current, overheating, V_{DD} fault, V_{PC} fault, V_{CC} fault, and card extraction during the session. To be noted that V_{PC} and V_{CC} faults are linked together so that a fault is generated when V_{PC} goes lower than V_{CC} .

The following steps show the deactivation sequence and the timing of the card control signals when the system controller sets the $\overline{\text{CMDVCC}}$ high or $\overline{\text{OFF}}$ goes low due to a fault or card removal:

- RST goes low at the end of t_1 .
- CLK is set low at the end of t_2 .
- I/O goes low at the end of t_3 . Out of reception mode.
- V_{CC} is shut down at the end of time t_4 . After a delay t_5 (discharge of the V_{CC} capacitor), V_{CC} is low.

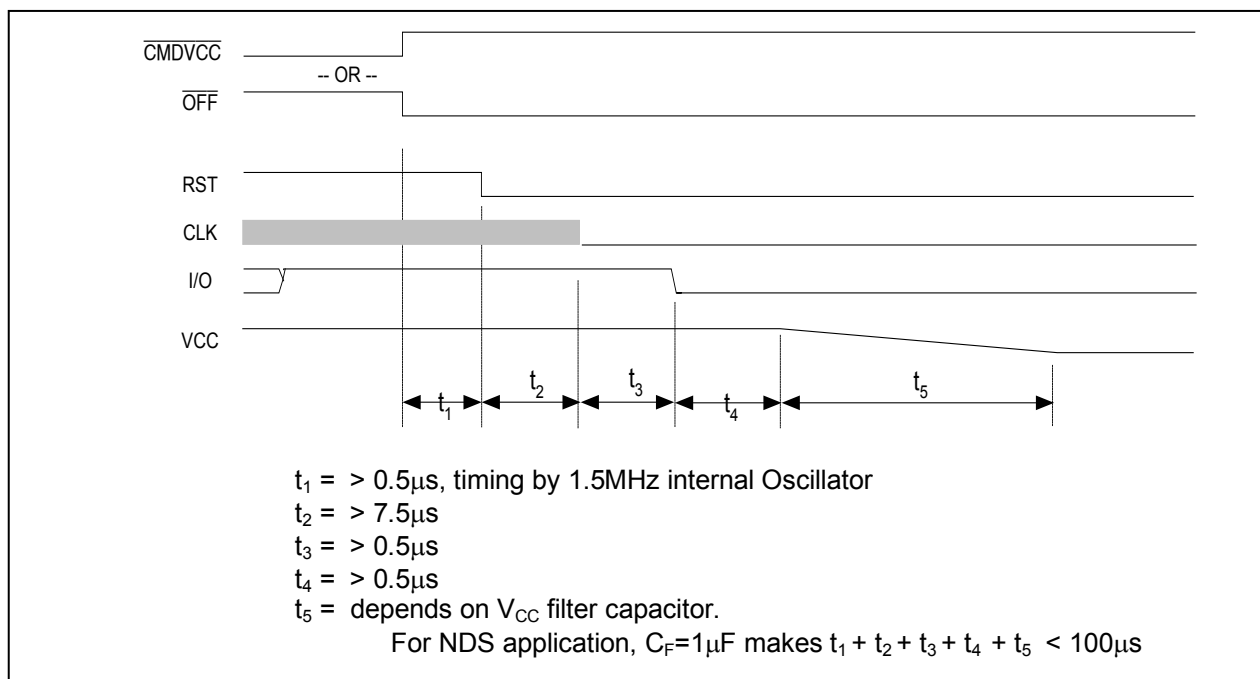

Figure 4: Deactivation Sequence

9 $\overline{\text{OFF}}$ and Fault Detection

There are two different cases that the system controller can monitor the $\overline{\text{OFF}}$ signal: to query regarding the card presence outside card sessions, or for fault detection during card sessions.

Outside a card session: In this condition, $\overline{\text{CMDVCC}}$ is always high, $\overline{\text{OFF}}$ is low if the card is not present, and high if the card is present. Because it is outside a card session, any fault detection will not act upon the $\overline{\text{OFF}}$ signal. No deactivation is required during this time.

During a card session: $\overline{\text{CMDVCC}}$ is always low, and $\overline{\text{OFF}}$ falls low if the card is extracted or if any fault detection is detected. At the same time that $\overline{\text{OFF}}$ is set low, the sequencer starts the deactivation process.

The Figure 5 shows the timing diagram for the signals $\overline{\text{CMDVCC}}$, PRES, and $\overline{\text{OFF}}$ during a card session and outside the card session:

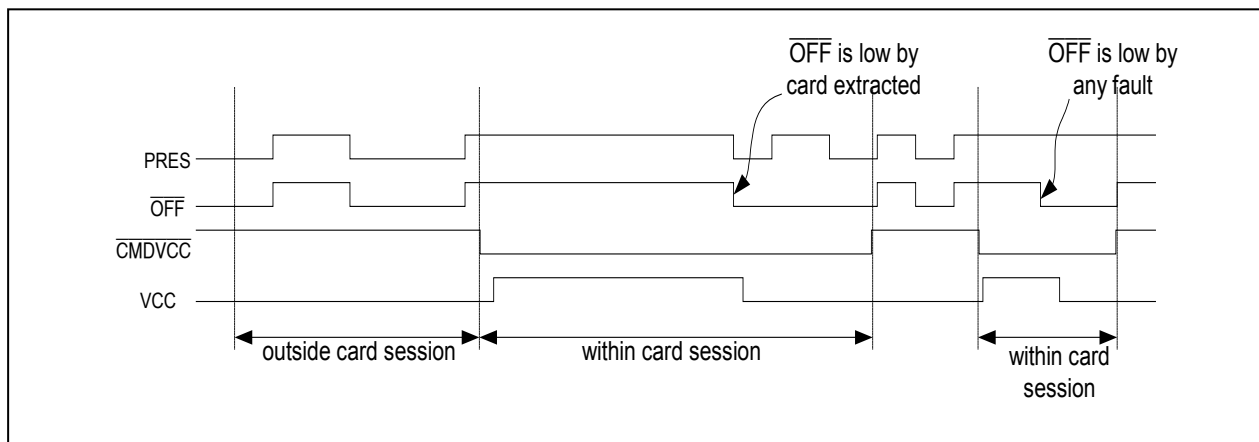

Figure 5: Timing Diagram – Management of the Interrupt Line $\overline{\text{OFF}}$

10 I/O Circuitry and Timing

The states of the I/O, AUX1, and AUX2 pins are low after power on reset and they are in high when the activation sequencer turns on the I/O reception state. See the [Activation Sequence](#) section for more details on when the I/O reception is enabled. The states of I/OUC, AUX1UC, and AUX2UC are high after power on reset.

Within a card session and when the I/O reception state is turn on, the first I/O line on which a falling edge is detected becomes the input I/O line and the other becomes the output I/O line. When the input I/O line rising edge is detected then both I/O lines return to their neutral state.

Figure 6 shows the state diagram of how the I/O and I/OUC lines are managed to become input or output. The delay between the I/O signals is shown in Figure 7.

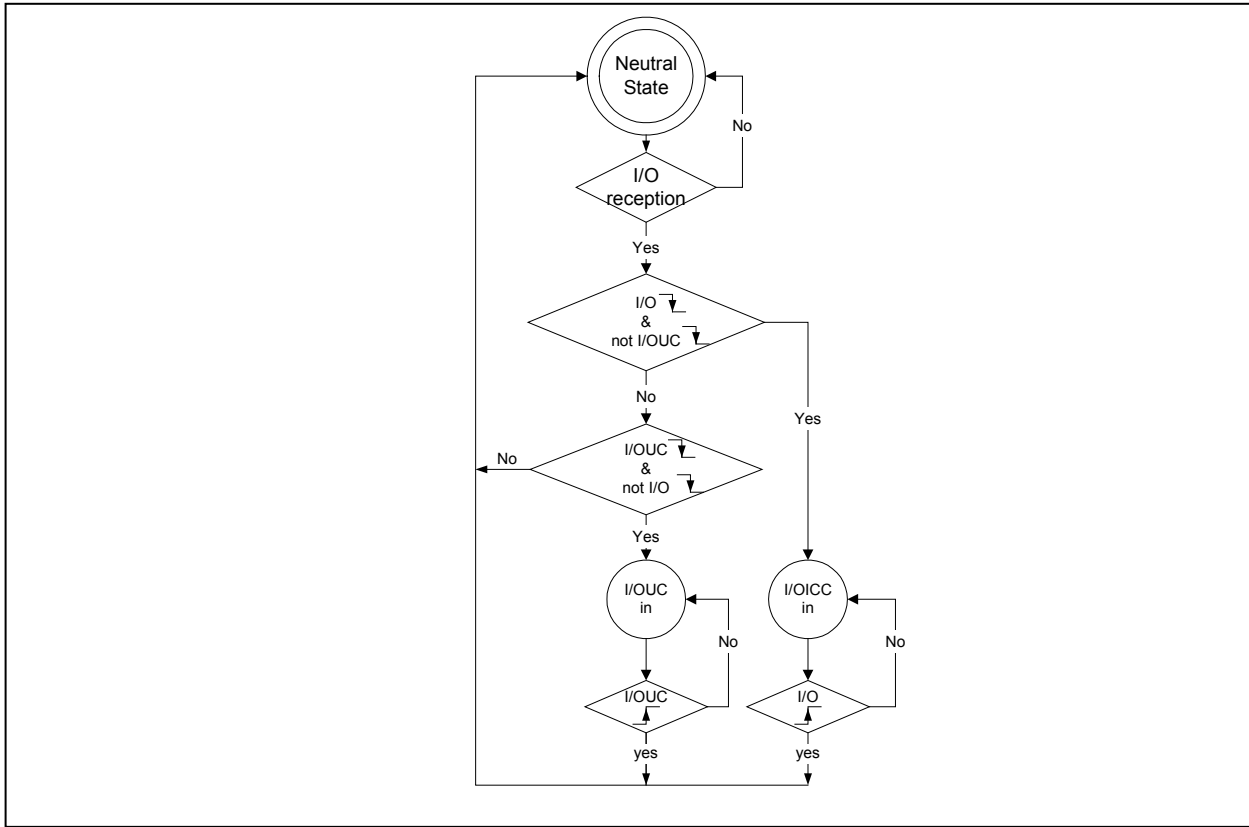

Figure 6: I/O and I/OUC State Diagram

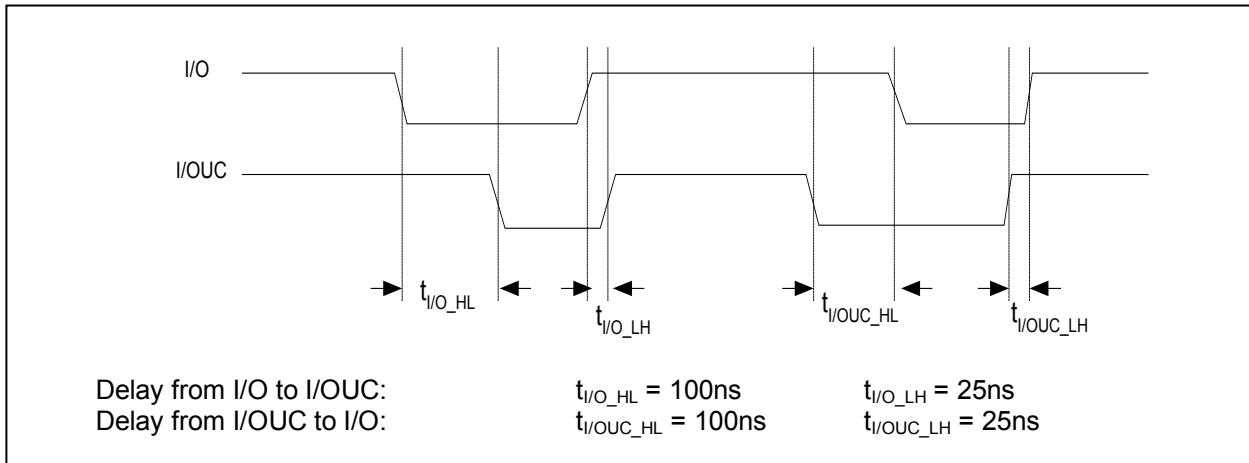

Figure 7: I/O – I/OUC Delays Timing Diagram

11 Typical Application Schematic

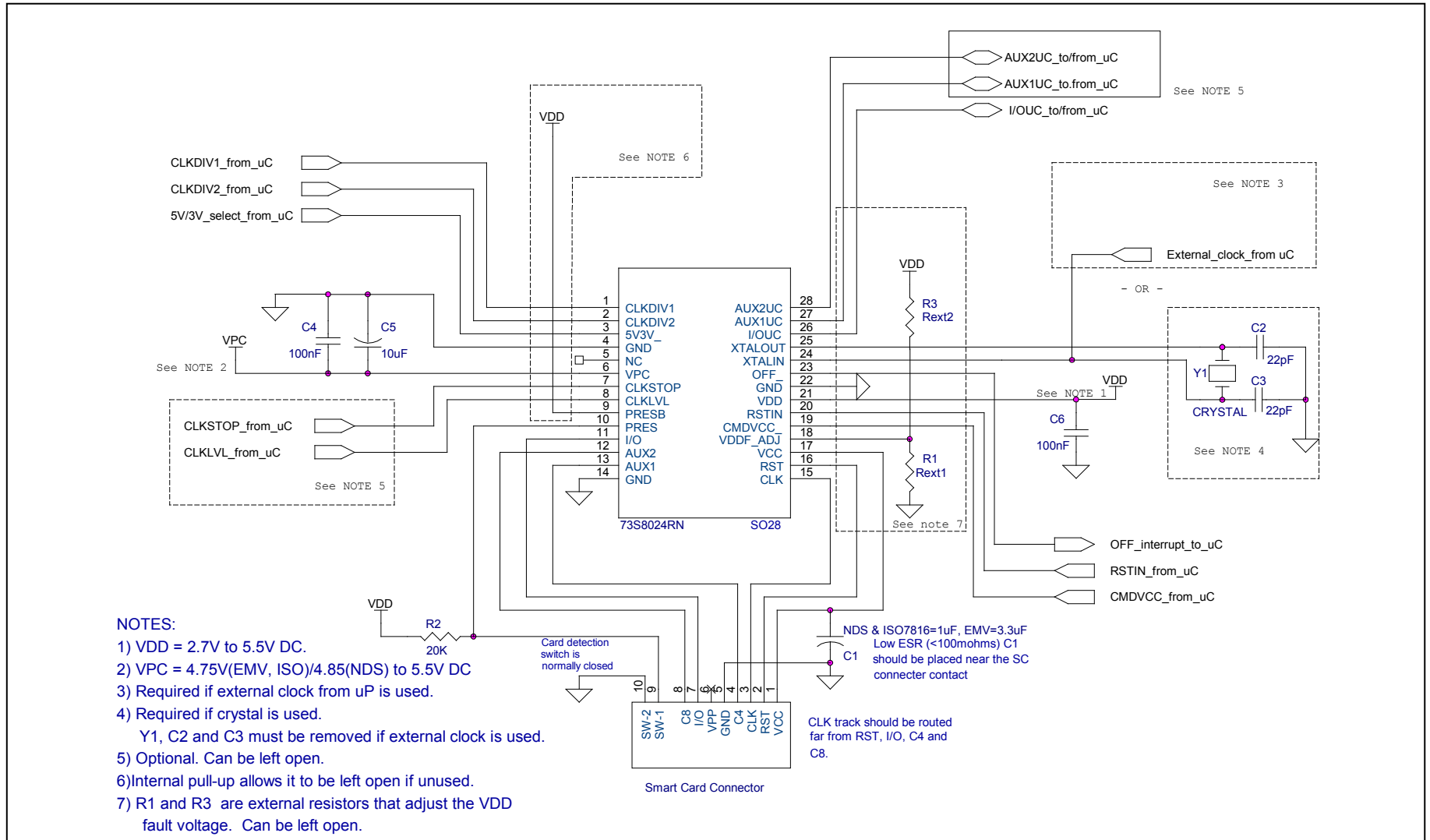

Figure 8: 73S8024RN – Typical Application Schematic

12 Electrical Specification

12.1 Absolute Maximum Ratings

Operation outside these rating limits may cause permanent damage to the device. The smart card interface pins are protected against short circuits to V_{CC} , ground, and each other.

| Parameter | Rating |
|-------------------------------------|--------------------------------|
| Supply Voltage V_{DD} | -0.5 to 6.0 VDC |
| Supply Voltage V_{PC} | -0.5 to 6.0 VDC |
| Input Voltage for Digital Inputs | -0.3 to ($V_{DD} + 0.5$) VDC |
| Storage Temperature | -60 to 150°C |
| Pin Voltage (except card interface) | -0.3 to ($V_{DD} + 0.5$) VDC |
| Pin Voltage (card interface) | -0.3 to ($V_{CC} + 0.5$) VDC |
| ESD Tolerance – Card interface pins | +/- 6kV |
| ESD Tolerance – Other pins | +/- 2kV |

*Note: ESD testing on smart card pins is HBM condition, 3 pulses, each polarity referenced to ground.

Note: Smart Card pins are protected against shorts between any combinations of Smart Card pins.

12.2 Recommended Operating Conditions

| Parameter | Rating |
|----------------------------------|-----------------------|
| Supply Voltage V_{DD} | 2.7 to 5.5 VDC |
| Supply Voltage V_{PC} | 4.75 to 5.5 VDC |
| NDS Supply Voltage V_{PC} | 4.85 to 5.5 VDC |
| Ambient Operating Temperature | -40°C to +85°C |
| Input Voltage for Digital Inputs | 0V to $V_{DD} + 0.3V$ |

12.3 Package Thermal Parameters

| Package | Rating |
|---------|---|
| 28 SO | 44 °C / W |
| 32QFN | 47 °C / W (with bottom pad soldered) |
| 32QFN | 78 °C / W (without bottom pad soldered) |
| 20QFN | 53 °C / W (with the bottom pad soldered) |
| 20QFN | 90 °C / W (without the bottom pad soldered) |

12.4 Smart Card Interface Requirements

| Symbol | Parameter | Condition | Min | Typ | Max | Unit |
|---|---|--|------|-------|------|------------------|
| Card Power Supply (V_{CC}) Regulator | | | | | | |
| General conditions, $-40^{\circ}\text{C} < T < 85^{\circ}\text{C}$, $4.75\text{v} < V_{PC} < 5.5\text{v}$, $2.7\text{v} < V_{DD} < 5.5\text{v}$ | | | | | | |
| NDS conditions, $4.85\text{v} < V_{PC} < 5.5\text{v}$ | | | | | | |
| V_{CC} | Card supply voltage including ripple and noise | Inactive mode | -0.1 | | 0.1 | V |
| | | Inactive mode $I_{CC} = 1\text{mA}$ | -0.1 | | 0.4 | V |
| | | Active mode; $I_{CC} < 65\text{mA}$; 5v | 4.60 | | 5.25 | V |
| | | Active mode; $I_{CC} < 65\text{mA}$; 5v, NDS condition | 4.75 | | 5.25 | V |
| | | Active mode; $I_{CC} < 90\text{mA}$; 5v | 4.55 | | 5.25 | V |
| | | Active mode; $I_{CC} < 90\text{mA}$; 3v | 2.80 | | 3.2 | V |
| | | Active mode; single pulse of 100mA for 2 μs ; 5 volt, fixed load = 25mA | 4.6 | | 5.25 | V |
| | | Active mode; single pulse of 100mA for 2 μs ; 3v, fixed load = 25mA | 2.76 | | 3.2 | V |
| | | Active mode; current pulses of 40nAs with peak $ I_{CC} < 200\text{mA}$, $t < 400\text{ns}$; 5v | 4.6 | | 5.25 | V |
| | | Active mode; current pulses of 40nAs with peak $ I_{CC} < 200\text{mA}$, $t < 400\text{ns}$; 5v, NDS condition | 4.65 | | 5.25 | V |
| | | Active mode; current pulses of 40nAs with peak $ I_{CC} < 200\text{mA}$, $t < 400\text{ns}$; 3v | 2.76 | | 3.2 | V |
| V_{CCrip} | V_{CC} Ripple | $f_{RIPPLE} = 20\text{K} - 200\text{MHz}$ | | | 350 | mV |
| I_{CCmax} | Card supply output current | Static load current, $V_{CC} > 4.6$ | 65 | | | mA |
| | | Static load current, $V_{CC} > 4.55$ or 2.7 volts as selected | 90 | | | mA |
| I_{CCF} | I_{CC} fault current | | 90 | | 150 | mA |
| $V_{SR} - V_{SF}$ | V_{CC} slew rate - | $C_F = 3.3\mu\text{F}$ on V_{CC} | 0.02 | 0.050 | 0.08 | V/ μs |
| $V_{SRN} - V_{SFN}$ | V_{CC} slew rate | $C_F = 1.0\mu\text{F}$ on V_{CC} NDS applications | 0.06 | 0.160 | 0.26 | V/ μs |
| C_F | External filter capacitor (V_{CC} to GND) | C_F should be ceramic with low ESR ($< 100\text{m}\Omega$). | 1 | 3.3 | 5 | μF |
| C_{FNDS} | External filter capacitor (V_{CC} to GND) | NDS applications C_F should be ceramic with low ESR ($< 100\text{m}\Omega$). | 0.5 | 1.0 | 1.5 | μF |

| Symbol | Parameter | Condition | Min | Typ | Max | Unit |
|--|--|---|----------------------|-----|-----------------------|------|
| Interface Requirements – Data Signals: I/O, AUX1, AUX2, and host interfaces: I/OUC, AUX1UC, AUX2UC. | | | | | | |
| I_{SHORTL}, I_{SHORTH}, and V_{INACT} requirements do not pertain to I/OUC, AUX1UC, and AUX2UC. | | | | | | |
| V _{OH} | Output level, high (I/O, AUX1, AUX2) | I _{OH} = 0 | 0.9 V _{CC} | | V _{CC} +0.1 | V |
| | | I _{OH} = -40μA | 0.75 V _{CC} | | V _{CC} +0.1 | V |
| V _{OH} | Output level, high (I/OUC, AUX1UC, AUX2UC) | I _{OH} = 0 | 0.9 V _{DD} | | V _{DD} +0.1 | V |
| | | I _{OH} = -40μA | 0.75 V _{DD} | | V _{DD} +0.1 | V |
| V _{OL} | Output level, low | I _{OL} =1mA | | | 0.3 | V |
| V _{IH} | Input level, high (I/O, AUX1, AUX2) | | 1.8 | | V _{CC} +0.30 | V |
| V _{IH} | Input level, high (I/OUC, AUX1UC, AUX2UC) | | 1.8 | | V _{DD} +0.30 | V |
| V _{IL} | Input level, low | | -0.3 | | 0.8 | V |
| V _{INACT} | Output voltage when outside of session | I _{OL} = 0 | | | 0.1 | V |
| | | I _{OL} = 1mA | | | 0.3 | V |
| I _{LEAK} | Input leakage | V _{IH} = V _{CC} | | | 10 | μA |
| I _{IL} | Input current, low | V _{IL} = 0 | | | 0.65 | mA |
| I _{SHORTL} | Short circuit output current | For output low, shorted to V _{CC} through 33 ohms | | | 15 | mA |
| I _{SHORTH} | Short circuit output current | For output high, shorted to ground through 33 ohms | | | 15 | mA |
| t _R , t _F | Output rise time, fall times | For I/O, AUX1, AUX2, C _L = 80pF, 10% to 90%. For I/OUC, AUX1UC, AUX2UC, C _L =50Pf, 10% to 90%. | | | 100 | ns |
| t _{IR} , t _{IF} | Input rise, fall times | | | | 1 | μs |
| R _{PU} | Internal pull-up resistor | Output stable for >200ns | 8 | 11 | 14 | kΩ |
| FD _{MAX} | Maximum data rate | | | | 1 | MHz |
| T _{FDIO} | Delay, I/O to I/OUC, AUX1 to AUX1UC, AUX2 to AUX2UC, I/OUC to I/O, AUX1UC to AUX1, AUX2UC to AUX2 (respectively falling edge to falling edge and rising edge to rising edge) | Edge from master to slave, measured at 50% | 60 | 100 | 200 | ns |
| T _{RDIO} | | | | 25 | 90 | ns |
| C _{IN} | Input capacitance | | | | 10 | pF |

| Symbol | Parameter | Condition | Min | Typ | Max | Unit |
|---|--|--|---------------------|-----|-----------------|------|
| Reset and Clock for card interface, RST, CLK | | | | | | |
| V _{OH} | Output level, high | I _{OH} = -200μA | 0.9 V _{CC} | | V _{CC} | V |
| V _{OL} | Output level, low | I _{OL} = 200μA | 0 | | 0.3 | V |
| V _{INACT} | Output voltage when outside of session | I _{OL} = 0 | | | 0.1 | V |
| | | I _{OL} = 1mA | | | 0.3 | V |
| I _{RST_LIM} | Output current limit, RST | | | | 30 | mA |
| I _{CLK_LIM} | Output current limit, CLK | | | | 70 | mA |
| CLK _{SR3V} | CLK slew rate | V _{CC} = 3V | 0.3 | | | V/ns |
| CLK _{SR5V} | CLK slew rate | V _{CC} = 5V | 0.5 | | | V/ns |
| t _R , t _F | Output rise time, fall time | C _L = 35pF for CLK, 10% to 90% | | | 8 | ns |
| | | C _L = 200pF for RST, 10% to 90% | | | 100 | ns |
| δ | Duty cycle for CLK | C _L = 35pF, F _{CLK} ≤ 20MHz | 45 | | 55 | % |

12.5 Characteristics: Digital Signals

| Symbol | Parameter | Condition | Min | Typ | Max | Unit |
|---|---|--|------------------------|-----|-----------------------|------|
| Digital I/O Except for OSC I/O | | | | | | |
| V _{IL} | Input Low Voltage | | -0.3 | | 0.8 | V |
| V _{IH} | Input High Voltage | | 0.7 V _{DD} | | V _{DD} + 0.3 | V |
| V _{OL} | Output Low Voltage | I _{OL} = 2mA | | | 0.45 | V |
| V _{OH} | Output High Voltage | I _{OH} = -1mA | V _{DD} - 0.45 | | | V |
| R _{OUT} | Pull-up resistor, $\overline{\text{OFF}}$ | | 16 | 21 | 24 | kΩ |
| I _{IL1} | Input Leakage Current | GND < V _{IN} < V _{DD} | -5 | | 5 | μA |
| Oscillator (XTALIN) I/O Parameters | | | | | | |
| V _{ILXTAL} | Input Low Voltage - XTALIN | | -0.3 | | 0.3 V _{DD} | V |
| V _{IHXTAL} | Input High Voltage - XTALIN | | 0.7 V _{DD} | | V _{DD} +0.3 | V |
| I _{ILXTAL} | Input Current - XTALIN | GND < V _{IN} < V _{DD} | -30 | | 30 | μA |
| f _{MAX} | Max freq. Osc or external clock | | | | 27 | MHz |
| δ _{in} | External input duty cycle limit | t _{R/F} < 10% f _{IN} , 45% < δ _{CLK} < 55% | 48 | | 52 | % |

12.6 DC Characteristics

| Symbol | Parameter | Condition | Min | Typ | Max | Unit |
|-------------|--|--|-----|-----|-----|---------|
| I_{DD} | Supply Current | | | 2.7 | 7.0 | mA |
| I_{PC} | Supply Current | V_{CC} on, ICC=0 I/O, AUX1, AUX2=high, Clock not toggling | | 450 | 650 | μ A |
| I_{PCOFF} | V_{PC} supply current when $V_{CC} = 0$ | \overline{CMDVCC} High | | 345 | 550 | μ A |

12.7 Voltage / Temperature Fault Detection Circuits

| Symbol | Parameter | Condition | Min | Typ | Max | Unit |
|-----------|---|--|------|----------------|------|--------------|
| V_{DDF} | V_{DD} fault (V_{DD} Voltage supervisor threshold) | No external resistor on VDDF_ADJ pin | 2.15 | | 2.4 | V |
| V_{PCF} | V_{PC} fault (V_{PC} Voltage supervisor threshold) | $V_{PC} < V_{CC}$, a transient event | | $V_{CC} - 0.2$ | | V |
| V_{CCF} | V_{CC} fault (V_{CC} Voltage supervisor threshold) | $V_{CC} = 5v$ | 4.20 | | 4.55 | V |
| | | $V_{CC} = 3v$ | 2.5 | | 2.7 | V |
| T_F | Die over temperature fault | | 115 | | 145 | $^{\circ}$ C |

13 Mechanical Drawing (20QFN)

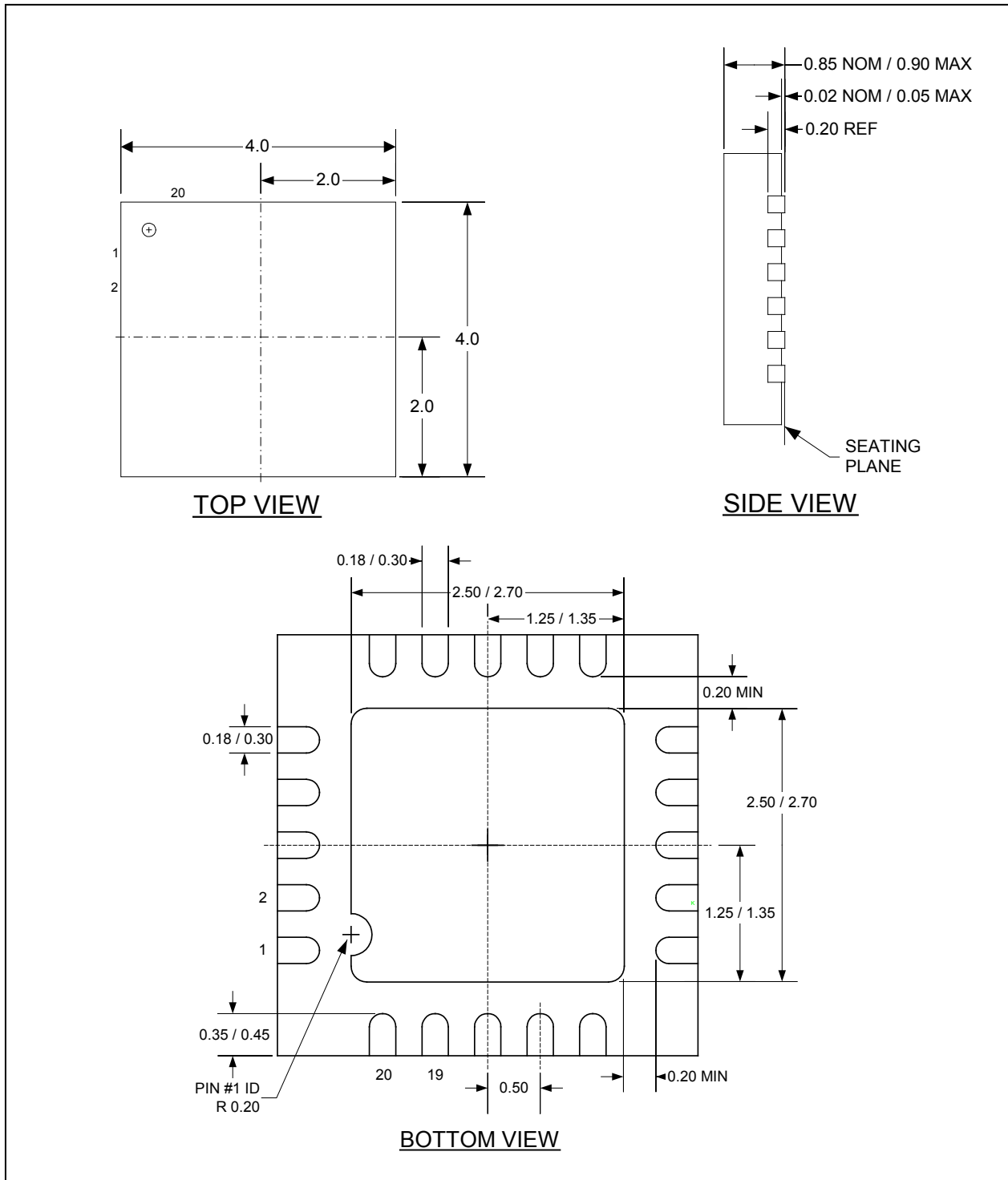

Figure 9: 20QFN Mechanical Drawing

14 Package Pin Designation (20QFN)

CAUTION: Use handling procedures necessary for a static sensitive component

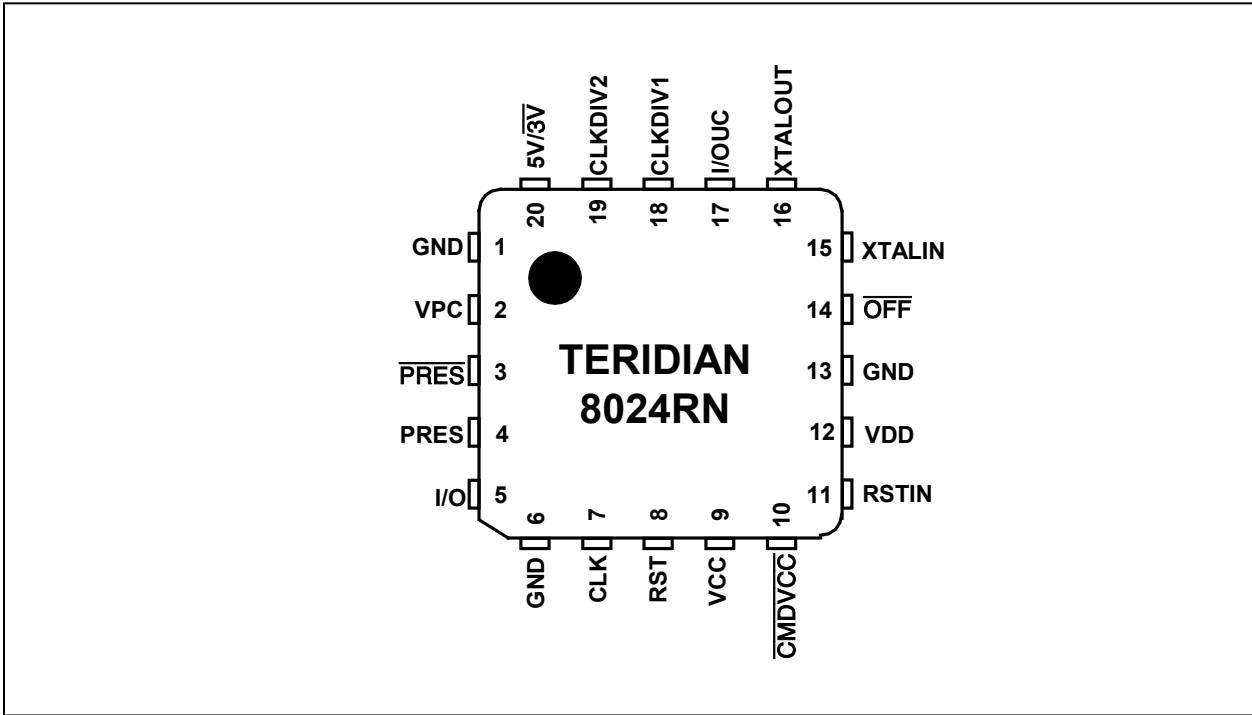

Figure 10: 20QFN Pin Out

16 Package Pin Designation (32QFN)

CAUTION: Use handling procedures necessary for a static sensitive component

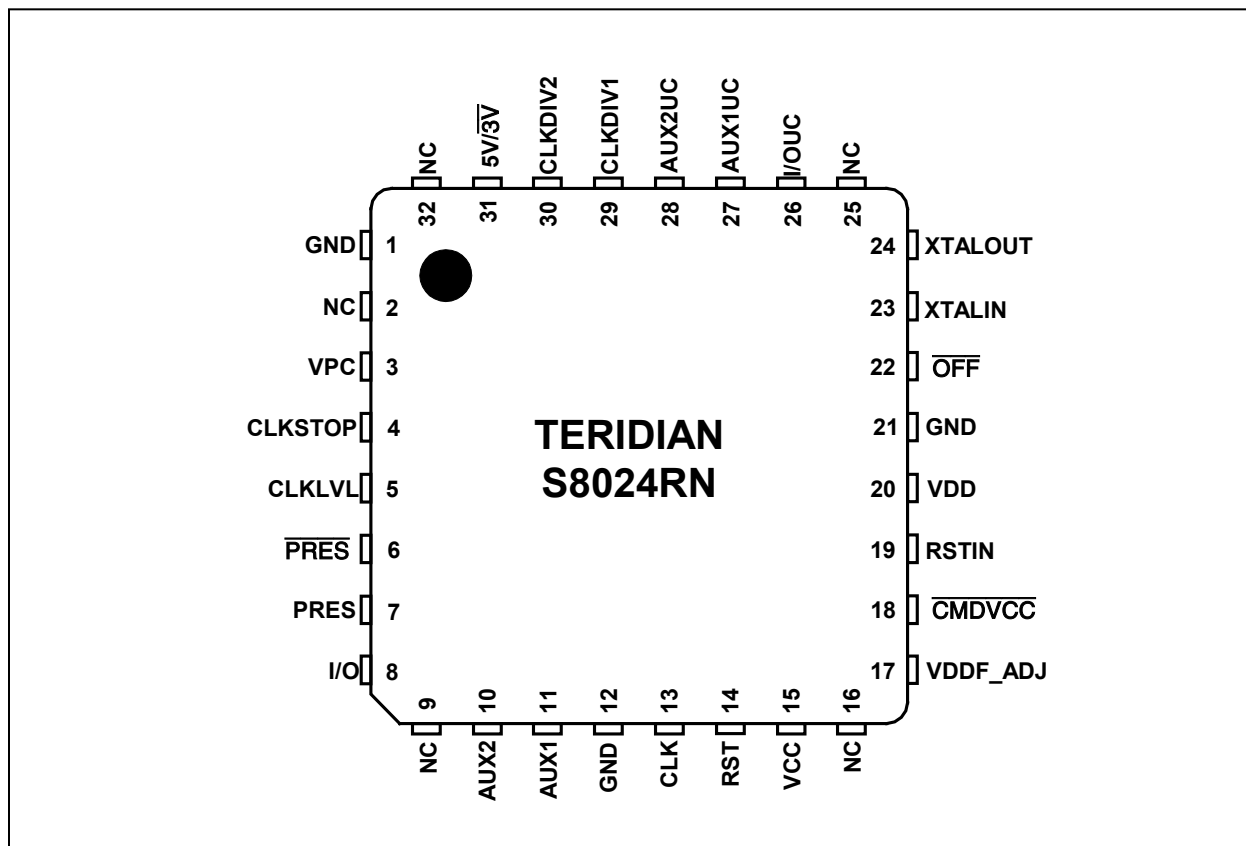

Figure 12: 32QFN Pin Out

17 Mechanical Drawing (SO)

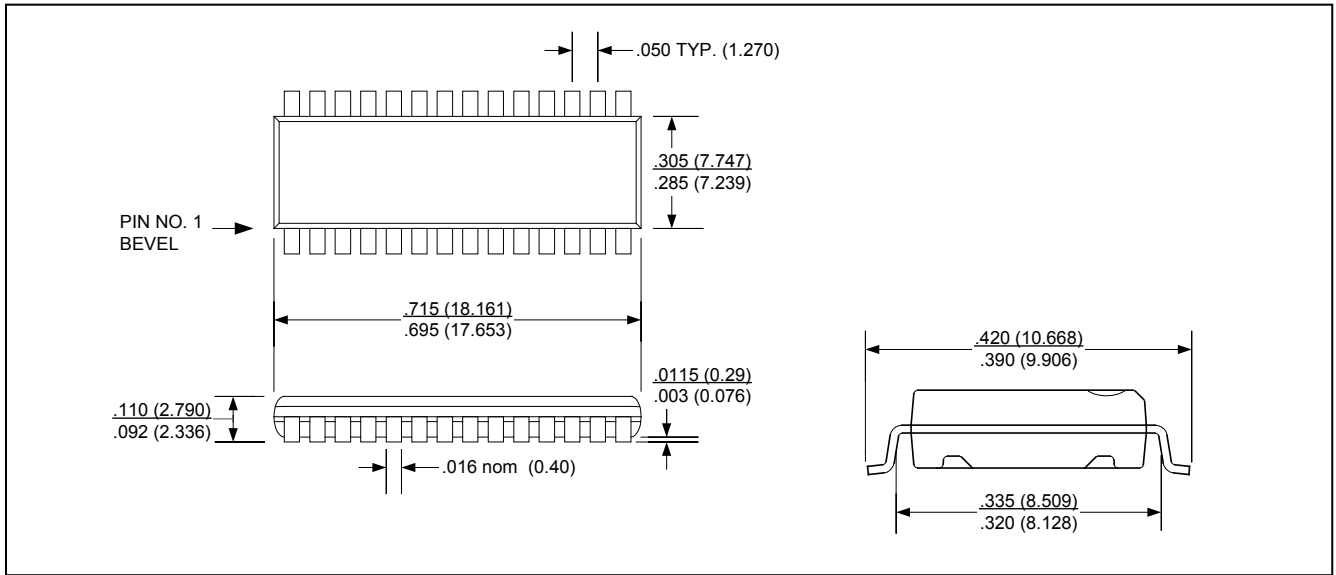

Figure 13: 28 Lead SO

18 Package Pin Designation (SO)

CAUTION: Use handling procedures necessary for a static sensitive component

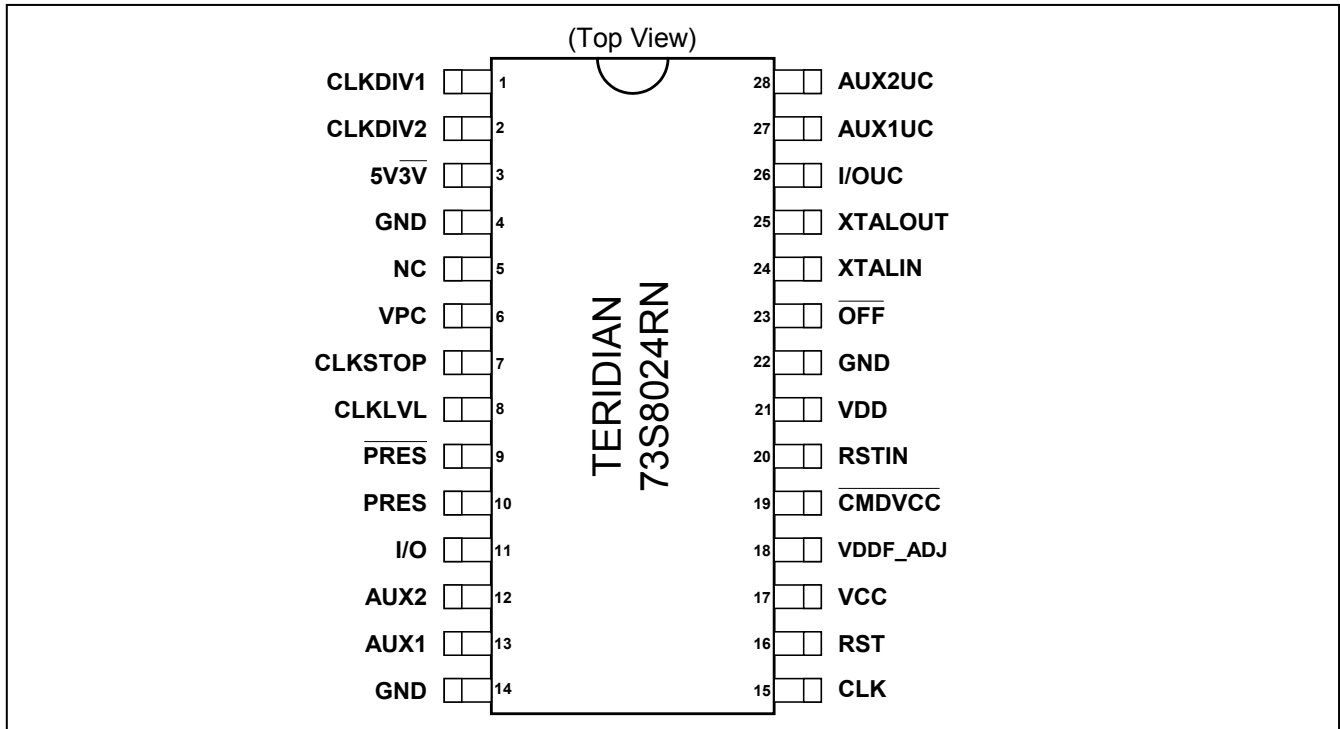

Figure 14: 28SO 73S8024RN Pin Out

19 Ordering Information

| Part Description | Order No. | Packaging Mark |
|---|-------------------|----------------|
| 73S8024RN-SOL 28-pin Lead-Free SO | 73S8024RN-IL/F | 73S8024RN-IL |
| 73S8024RN-SOL 28-pin Lead-Free SO Tape / Reel | 73S8024RN-ILR/F | 73S8024RN-IL |
| 73S8024RN-32QFN 32-pin Lead-Free QFN | 73S8024RN-IM/F | S8024RN |
| 73S8024RN-32QFN 32-pin Lead-Free QFN Tape / Reel | 73S8024RN-IMR/F | S8024RN |
| 73S8024RN-20QFN 20-pin Lead-Free QFN | 73S8024RN-20IM/F | 8024RN |
| 73S8024RN-20QFN 20-pin Lead-Free QFN Tape / Reel | 73S8024RN-20IMR/F | 8024RN |

20 Related Documentation

The following 73S8024RN documents are available from Maxim:

73S8024RN Data Sheet (this document)
73S8024RN Combination 28SO/20QFN Demo Board User Guide
73S8024RN 28SO Demo Board User's Guide
Achieving EMV Electrical Compliance with the TERIDIAN 73S8024RN
Dual Footprint Layout
73S8024RN vs NXP TDA8024T
Implementing the TERIDIAN 73S8024RN in NDS Applications

21 Contact Information

For more information about Maxim products or to check the availability of the 73S8024RN, contact technical support at www.maxim-ic.com/support.

Revision History

| Revision | Date | Description |
|----------|-----------|--|
| 1.1 | 5/18/2004 | First publication. |
| 1.2 | 11/5/2004 | |
| 1.3 | 4/27/2005 | Added 20QFN package option and ordering information. Updated 32 QFN ordering information. |
| 1.4 | 7/15/2005 | |
| 1.5 | 8/23/2005 | |
| 1.6 | 12/5/2007 | Removes leaded package options, replaces 32QFN punched with SAWN mechanical dimensions, update 28SO package dimensions. |
| 1.7 | 1/17/2008 | Changed dimension of bottom exposed pad on 32QFN mechanical package figure. |
| 1.8 | 1/19/2009 | In Figure 1 , modified the device block diagram to make pin 2 a no connect. Also, changed the pin description. In Figure 9 , changed the mechanical drawing for the 20QFN package. Added the NDS logo to page 1 and assigned document number. Added the Related Documentation and the Contact Information sections. |
| 1.9 | 5/27/2010 | Changed dimension of bottom exposed pad on 32QFN mechanical package figure. |
| 2 | 6/12 | Corrected the Order Numbers for the 73S8024RN-32QFN. Added Maxim logo and Contact Information. |

Maxim cannot assume responsibility for use of any circuitry other than circuitry entirely embodied in a Maxim product. No circuit patent licenses are implied. Maxim reserves the right to change the circuitry and specifications without notice at any time.

Maxim Integrated Products, Inc. 160 Rio Robles, San Jose, CA 95134 USA 1-408-601-1000

© 2012 Maxim Integrated Products

MAXIM is a registered trademark of Maxim Integrated Products Inc.

Looking for pricing, stock, or lifecycle information?

Click below to explore more details on WIN SOURCE:

 [View 73S8024RN-20IM/F on WIN SOURCE](#)

 [Maxim Integrated Information](#)

Optimize Your Supply Chain with WIN SOURCE Solutions

-  Global Sourcing Solution
-  Obsolete Management
-  Cost Control Management
-  Shortage Management
-  Alternative Solution
-  Excess Inventory Management