



**THE DATASHEET OF  
73S8014R-ILR/F**



**DESCRIPTION**

The Teridian 73S8014R is a single smart card (ICC) interface circuit, firmware compatible with 8024-type devices for configurations where only asynchronous cards must be supported. It is derived from the 73S8024RN industry-standard electrical interface. The 73S8014R has been optimized to match most of the typical Set-Top-Box / A/V Conditional Access applications. Optimization essentially involved a smaller pin-count, support for single I/O, and maximum card current of 65mA (ISO-7816 / EMV compliance).

The 73S8014R interfaces with the host processor through the same bus (digital I/Os) as the 73S8024RN, which is compatible with any other 8024-type IC. **As a result, the 73S8014R is a very attractive cost-reduction path from traditional 8024 ICs.** The 73S8014R has been designed to provide full electrical compliance with ISO 7816-3 and EMV 4.0 specifications.

Interfacing with the system controller is done through a control bus, composed of digital inputs to control the interface, and one interrupt output to inform the system controller of the card presence and faults.

The card clock can be generated by an on-chip oscillator using an external crystal or by connection to an externally supplied clock signal.

The 73S8014R incorporates an ISO 7816-3 activation/deactivation sequencer that controls the card signals. Level-shifters drive the card signals with the selected card voltage (3V or 5V), coming from an internal Low Drop-Out (LDO) voltage regulator. This LDO regulator is powered by a dedicated power supply input  $V_{PC}$ . Digital circuitry is powered separately by a digital power supply  $V_{DD}$ . With its embedded LDO regulator, the 73S8024RN is a cost-effective solution for any application where a 5V (typically -5% +10%) power supply is available.

Emergency card deactivation is initiated upon card extraction or upon any fault detected by the protection circuitry. The fault can be a card over-current, VCC undervoltage or power supply fault ( $V_{DD}$ ). The card over-current circuitry is a true current detection function, as opposed to  $V_{CC}$  voltage drop detection, as usually implemented in non-Teridian 8024 interface ICs.

The  $V_{DD}$  voltage fault has a threshold voltage that can be adjusted with an external resistor network. It allows automated card deactivation at a customized  $V_{DD}$  voltage threshold value. It can be used, for instance, to match the system controller operating voltage range.

**APPLICATIONS**

- **Set-Top-Box Conditional Access and Pay-per-View**
- **General purpose smart card readers**

**ADVANTAGES**

- **Same advantages as the Teridian 73S80xxR family:**
  - VCC card generated by an LDO regulator
  - Very low power dissipation (saves up to 1/2W)
  - Fewer external components are required
  - Better noise performance
- **True card over-current detection**
- **Firmware compatibility with all 8024 ICs**
- **Small format 20SO package**

**FEATURES**

- **Card Interface:**
  - Complies with ISO 7816-3 and EMV 4.0
  - Supports 3V / 5V cards
  - ISO 7816-3 Activation / Deactivation sequencer
  - Automated deactivation upon hardware fault (i.e. upon drop on  $V_{DD}$  power supply or card overcurrent)
  - The  $V_{DD}$  voltage supervisor threshold value (fault) can be externally adjusted
  - Over-current detection 130mA max
  - Card CLK clock frequency up to 20MHz
- **System Controller Interface:**
  - 3 Digital inputs control the card activation / deactivation, card reset and card voltage
  - 2 Digital inputs control the card clock frequency
  - 1 Digital output, interrupt to the system controller, reports to the host the card presence and faults
  - Crystal oscillator or host clock, up to 27MHz
- **Regulator Power Supply:**
  - 4.75V to 5.5V
- **Digital Interfacing: 2.7V to 5.5V**
- **6kV ESD protection on the card interface**
- **Package: SO 20-pin**
- **RoHS compliant (6/6) lead-free package**

**FUNCTIONAL DIAGRAM**

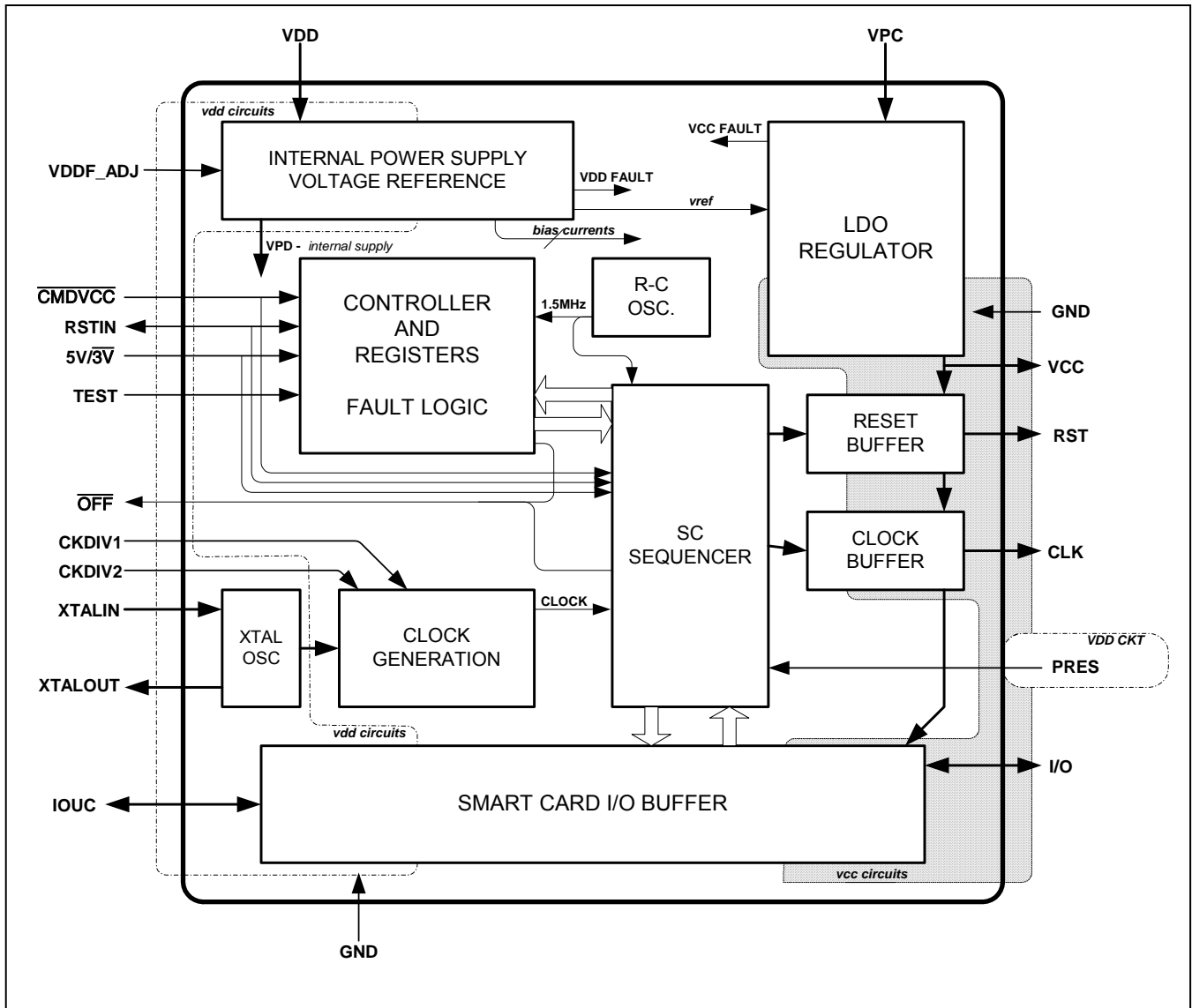

**Figure 1: 73S8014R Block Diagram**

## Table of Contents

<b>1</b>	<b>Pinout</b> .....	<b>5</b>
<b>2</b>	<b>Electrical Specifications</b> .....	<b>8</b>
2.1	Absolute Maximum Ratings .....	8
2.2	Recommended Operating Conditions .....	8
2.3	Package Thermal Parameters .....	9
2.4	Smart Card Interface Requirements .....	9
2.5	Characteristics: Digital Signals.....	11
2.6	DC Characteristics .....	12
2.7	Voltage Fault Detection Circuits.....	13
<b>3</b>	<b>Applications Information</b> .....	<b>14</b>
3.1	Example 73S8014R Schematics .....	14
3.2	System Controller Interface.....	16
3.3	Power Supply and Voltage Supervision.....	16
3.4	Card Power Supply .....	17
3.5	On-Chip Oscillator and Card Clock.....	17
3.6	Activation Sequence .....	18
3.7	Deactivation Sequence .....	19
3.8	Fault Detection and $\overline{\text{OFF}}$ .....	20
3.9	I/O Circuitry and Timing .....	20
<b>4</b>	<b>Equivalent Circuits</b> .....	<b>22</b>
<b>5</b>	<b>Mechanical Drawing</b> .....	<b>27</b>
<b>6</b>	<b>Ordering Information</b> .....	<b>28</b>
<b>7</b>	<b>Related Documentation</b> .....	<b>28</b>
<b>8</b>	<b>Contact Information</b> .....	<b>28</b>

## Figures

Figure 1: 73S8014R Block Diagram .....	2
Figure 2: 73S8014R 20-SOP Pin Out.....	5
Figure 3: 73S8014R – Typical Application Schematic .....	15
Figure 4: Activation Sequence – RSTIN Low When $\overline{\text{CMDVCC}}$ Goes Low .....	18
Figure 5: Activation Sequence – RSTIN High When $\overline{\text{CMDVCC}}$ Goes Low.....	19
Figure 6: Deactivation Sequence .....	19
Figure 7: Timing Diagram – Management of the Interrupt Line $\overline{\text{OFF}}$ .....	20
Figure 8: I/O and I/OUC State Diagram.....	21
Figure 9: I/O – I/OUC Delays – Timing Diagram .....	21
Figure 10: Open Drain type – $\overline{\text{OFF}}$ .....	22
Figure 11: Power Input/Output Circuit, VDD, VPC, VCC .....	22
Figure 12: Smart Card CLK Driver Circuit .....	23
Figure 13: Smart Card RST Driver Circuit.....	23
Figure 14: Smart Card IO Interface Circuit.....	24
Figure 15: Smart Card IOUC Interface Circuit.....	24
Figure 16: General Input Circuit .....	25
Figure 17: Oscillator Circuit .....	25
Figure 18: VDDF_ADJ .....	26
Figure 19: Mechanical Drawing 20-Pin SO Package .....	27

## Tables

Table 1: 73S8014R 20-Pin SOP Pin Definitions .....	6
Table 2: Absolute Maximum Device Ratings.....	8
Table 3: Recommended Operating Conditions .....	8
Table 4: Package Thermal Parameters.....	9
Table 5: DC Smart Card Interface Requirements .....	9
Table 6: Digital Signals Characteristics.....	11
Table 7: DC Characteristics.....	12
Table 8: Voltage Fault Detection Circuits .....	13
Table 9: Order Numbers and Packaging Marks .....	28

### 1 Pinout

The 73S8014R is supplied as a 20-pin SO package.

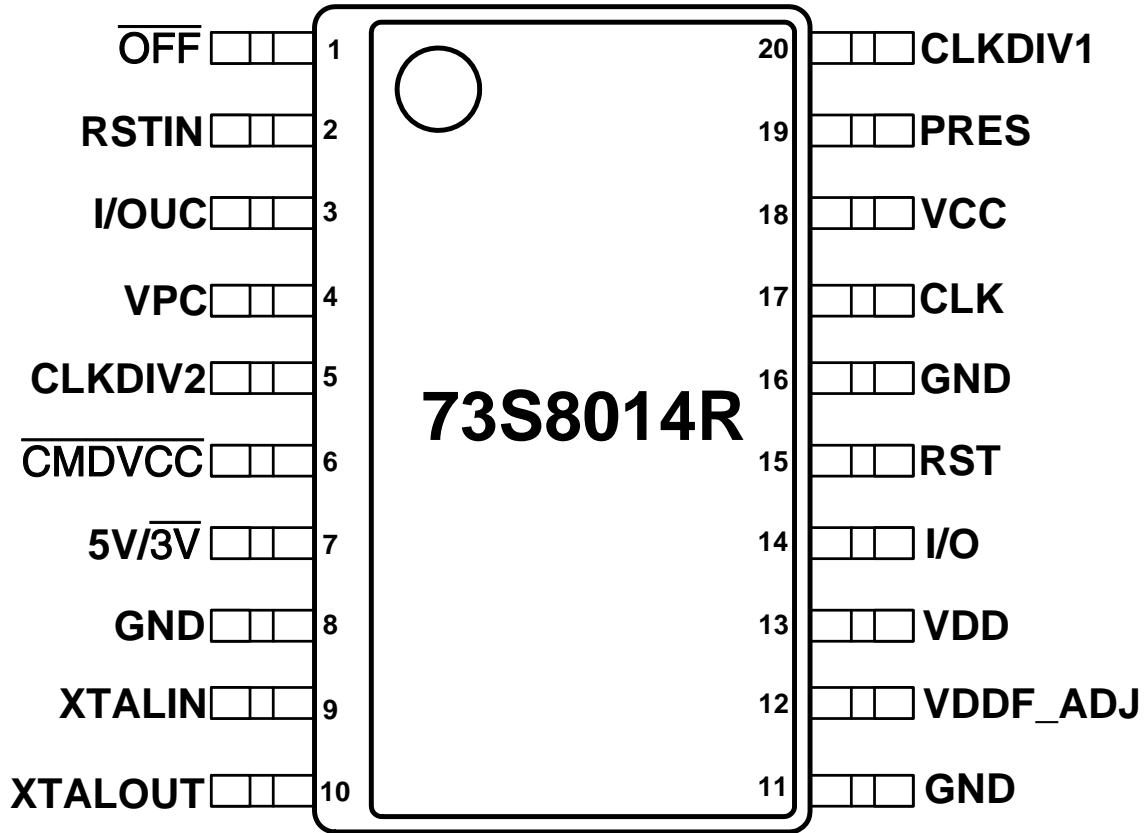

Figure 2: 73S8014R 20-SOP Pin Out

Table 1 provides the 73S8014R pin names, pin numbers, type, equivalent circuits and descriptions.

**Table 1: 73S8014R 20-Pin SOP Pin Definitions**

Pin Name	Pin Number	Type	Equivalent Circuit	Description															
<b>Card Interface</b>																			
I/O	14	IO	Figure 14	Card I/O: Data signal to/from card. Includes an 11k pull-up resistor to $V_{CC}$ .															
RST	15	O	Figure 13	Card reset: provides reset (RST) signal to card.															
CLK	17	O	Figure 12	Card clock: provides clock signal (CLK) to card. The rate of this clock is determined by the external crystal frequency or frequency of the external clock signal applied on XTALIN and CLKDIV selections.															
PRES	19	I	Figure 16	Card Presence switch: active high indicates card is present. Includes a high-impedance pull-down current source.															
VCC	18	PSO	Figure 11	Card power supply – logically controlled by sequencer, output of LDO regulator. Requires an external filter capacitor to the card GND.															
GND	16	GND	–	Card ground.															
<b>Host Processor Interface</b>																			
$\overline{\text{CMDVCC}}$	6	I	Figure 16	Command VCC (negative assertion): Logic low on this pin causes the LDO regulator to ramp the $V_{CC}$ supply to the card and initiates a card activation sequence, if a card is present.															
$5V/3V$	7	I	Figure 16	5 volt / 3 volt card selection: Logic one selects 5 volts for $V_{CC}$ and card interface, logic low selects 3 volt operation. When the part is to be used with a single card voltage, this pin should be tied to either GND or $V_{DD}$ . However, it includes a high impedance pull-up resistor to default this pin high (selection of 5V card) when not connected. This pin shall not be changed when CMDVCC is low.															
CLKDIV1 CLKDIV2	20 5	I	Figure 16	<p>Sets the divide ratio from the XTAL oscillator (or external clock input) to the card clock. These pins include a pull-up resistor for CLKDIV1 and CLKDIV2 to provide a default rate of divide by two.</p> <table border="1"> <thead> <tr> <th>CLKDIV1</th> <th>CLKDIV2</th> <th>CLOCK RATE</th> </tr> </thead> <tbody> <tr> <td>0</td> <td>0</td> <td>XTALIN/8</td> </tr> <tr> <td>0</td> <td>1</td> <td>XTALIN/4</td> </tr> <tr> <td>1</td> <td>1</td> <td>XTALIN/2</td> </tr> <tr> <td>1</td> <td>0</td> <td>XTALIN</td> </tr> </tbody> </table>	CLKDIV1	CLKDIV2	CLOCK RATE	0	0	XTALIN/8	0	1	XTALIN/4	1	1	XTALIN/2	1	0	XTALIN
CLKDIV1	CLKDIV2	CLOCK RATE																	
0	0	XTALIN/8																	
0	1	XTALIN/4																	
1	1	XTALIN/2																	
1	0	XTALIN																	
$\overline{\text{OFF}}$	1	O	Figure 10	Interrupt signal to the processor. Active Low - Multi-function indicating fault conditions and card presence. Open drain output configuration – It includes an internal 20k $\Omega$ pull-up to $V_{DD}$ .															
RSTIN	2	I	Figure 16	Reset Input: This signal is the reset command to the card.															
I/OUC	3	IO	Figure 15	System controller data I/O to/from the card. Includes an 11K pull-up resistor to $V_{DD}$ .															

<b>Miscellaneous Inputs and Outputs</b>				
XTALIN	9		<a href="#">Figure 17</a>	Crystal oscillator input: can either be connected to crystal or driven as a source for the card clock. Note: When not using the crystal, the capacitors must be removed.
XTALOUT	10		<a href="#">Figure 17</a>	Crystal oscillator output: connected to crystal. Left open if XTALIN is being used as external clock input. Note: When not using the crystal, the capacitors must be removed.
VDDF_ADJ	12		<a href="#">Figure 18</a>	$V_{DD}$ fault threshold adjustment input: this pin can be used to adjust the $V_{DDF}$ value (that controls deactivation of the card). Must be left open if unused.
<b>Power Supply and Ground</b>				
VDD	13	PSO	<a href="#">Figure 11</a>	System interface supply voltage and supply voltage for internal circuitry.
VPC	4	PSO	<a href="#">Figure 11</a>	LDO regulator power supply source.
GND	8, 11	GND	–	Digital ground.

## 2 Electrical Specifications

This section provides the following:

- Absolute maximum ratings
- Recommended operating conditions
- Package thermal parameters
- Smart card interface requirements
- Digital signals characteristics
- DC Characteristics
- Voltage Fault Detection Circuits

### 2.1 Absolute Maximum Ratings

Table 2 lists the maximum operating conditions for the 73S8014R. Permanent device damage may occur if absolute maximum ratings are exceeded. Exposure to the extremes of the absolute maximum rating for extended periods may affect device reliability. The smart card interface pins are protected against short circuits to  $V_{CC}$ , ground, and each other.

**Table 2: Absolute Maximum Device Ratings**

Parameter	Rating
Supply Voltage $V_{DD}$	-0.5 to 6.0 VDC
Supply Voltage $V_{PC}$	-0.5 to 6.0 VDC
Input Voltage for Digital Inputs	-0.3 to ( $V_{DD} + 0.5$ ) VDC
Storage Temperature	-60 to 150°C
Pin Voltage (except card interface)	-0.3 to ( $V_{DD} + 0.5$ ) VDC
Pin Voltage (card interface)	-0.3 to ( $V_{CC} + 0.5$ ) VDC
ESD Tolerance – Card interface pins	+/- 6kV
ESD Tolerance – Other pins	+/- 2kV

\*Note: ESD testing on smart card pins is HBM condition, 3 pulses, each polarity referenced to ground.

Note: Smart Card pins are protected against shorts between any combinations of Smart Card pins.

### 2.2 Recommended Operating Conditions

Function operation should be restricted to the recommended operating conditions specified in Table 3.

**Table 3: Recommended Operating Conditions**

Parameter	Rating
Supply Voltage $V_{DD}$	2.7 to 5.5 VDC
Supply Voltage $V_{PC}$	4.75 to 5.5 VDC
Ambient Operating Temperature	-40°C to +85°C
Input Voltage for Digital Inputs	0V to $V_{DD} + 0.3V$

## 2.3 Package Thermal Parameters

Table 4 lists the 73S8014R Smart Card interface requirements.

**Table 4: Package Thermal Parameters**

Parameter	Rating
20 SO	50 °C / W

## 2.4 Smart Card Interface Requirements

Table 5 lists the 73S8014R Smart Card interface requirements.

**Table 5: DC Smart Card Interface Requirements**

Symbol	Parameter	Condition	Min	Nom	Max	Unit
<b>Card Power Supply (<math>V_{CC}</math>) Regulator</b>						
<b>General conditions, <math>-40^{\circ}\text{C} &lt; T &lt; 85^{\circ}\text{C}</math>, <math>4.75\text{V} &lt; V_{PC} &lt; 5.5\text{V}</math>, <math>2.7\text{V} &lt; V_{DD} &lt; 5.5\text{V}</math></b>						
$V_{CC}$	Card supply voltage including ripple and noise	Inactive mode	-0.1		0.1	V
		Inactive mode, $I_{CC} = 1\text{mA}$	-0.1		0.4	V
		Active mode; $I_{CC} < 65\text{mA}$ ; 5V	4.65		5.25	V
		Active mode; $I_{CC} < 65\text{mA}$ ; 3V	2.85		3.15	V
		Active mode; $I_{CC} < 40\text{mA}$ ; 1.8V	1.68		1.92	V
		Active mode; single pulse of 100mA for 2 $\mu\text{s}$ ; 5 volt, fixed load = 25mA	4.6		5.25	V
		Active mode; single pulse of 100mA for 2 $\mu\text{s}$ ; 3v, fixed load = 25mA	2.76		3.2	V
		Active mode; current pulses of 40nAs with peak $ I_{CC}  < 200\text{mA}$ , $t < 400\text{ns}$ ; 5V	4.6		5.25	V
		Active mode; current pulses of 40nAs with peak $ I_{CC}  < 200\text{mA}$ , $t < 400\text{ns}$ ; 3V	2.7		3.15	V
$V_{CCrip}$	$V_{CC}$ Ripple	$f_{RIPPLE} = 20\text{K} - 200\text{MHz}$			350	mV
$I_{CCmax}$	Card supply output current	Static load current, $V_{CC} > 4.6\text{V}$ or 2.7V as selected	65			mA
$I_{CCF}$	$I_{CC}$ fault current		70		130	mA
$V_{SR}$	$V_{CC}$ slew rate, rise	$C_F = 1.0\mu\text{F}$ on $V_{CC}$	0.06	0.150	0.30	V/ $\mu\text{s}$
$V_{SF}$	$V_{CC}$ slew rate, fall	$C_F = 1.0\mu\text{F}$ on $V_{CC}$	0.075	0.150	0.60	V/ $\mu\text{s}$
$C_F$	External filter cap ( $V_{CC}$ to GND)	$C_F$ should be ceramic with low ESR (<100m $\Omega$ ).	0.5	1.0	1.5	$\mu\text{F}$

Symbol	Parameter	Condition	Min	Nom	Max	Unit
<b>Interface Requirements – Data Signals: I/O and host interfaces: I/OUC.</b>						
<b>I<sub>SHORTL</sub>, I<sub>SHORTH</sub>, and V<sub>INACT</sub> requirements do not pertain to I/OUC.</b>						
V <sub>OH</sub>	Output level, high (I/O)	I <sub>OH</sub> = 0	0.9 V <sub>CC</sub>		V <sub>CC</sub> +0.1	V
		I <sub>OH</sub> = -40μA	0.75 V <sub>CC</sub>		V <sub>CC</sub> +0.1	V
	Output level, high (I/OUC)	I <sub>OH</sub> = 0	0.9 V <sub>DD</sub>		V <sub>DD</sub> +0.1	V
		I <sub>OH</sub> = -40μA	0.75 V <sub>DD</sub>		V <sub>DD</sub> +0.1	V
V <sub>OL</sub>	Output level, low (I/O)				0.15 V <sub>CC</sub>	V
	Output level, low (I/OUC)	I <sub>OL</sub> = 1mA			0.3	V
V <sub>IH</sub>	Input level, high (I/O)		0.6 V <sub>CC</sub>		V <sub>CC</sub> +0.30	V
	Input level, high (I/OUC)		1.8		V <sub>DD</sub> + 0.3	V
V <sub>IL</sub>	Input level, low (I/O)		-0.15		0.2 V <sub>CC</sub>	V
	Input level, low (I/OUC)		-0.3		0.8	V
V <sub>INACT</sub>	Output voltage when outside of session	I <sub>OL</sub> = 0			0.1	V
		I <sub>OL</sub> = 1mA			0.3	V
I <sub>LEAK</sub>	Input leakage	V <sub>IH</sub> = V <sub>CC</sub>			10	μA
I <sub>IL</sub>	Input current, low	V <sub>IL</sub> = 0			0.65	mA
I <sub>SHORTL</sub>	Short circuit output current	For output low, shorted to V <sub>CC</sub> through 33 Ω			15	mA
I <sub>SHORTH</sub>	Short circuit output current	For output high, shorted to ground through 33 Ω			15	mA
t <sub>R</sub> , t <sub>F</sub>	Output rise time, fall times	C <sub>L</sub> = 80pF, 10% to 90%.			100	ns
t <sub>IR</sub> , t <sub>IF</sub>	Input rise, fall times				1	μs
R <sub>PU</sub>	Internal pull-up resistor	Output stable for >400ns	8	11	14	kΩ
FD <sub>MAX</sub>	Maximum data rate				1	MHz
T <sub>FDIO</sub>	Delay, I/O to I/OUC, I/OUC to I/O, (respectively falling edge to falling edge and rising edge to rising edge)	Edge from master to slave, measured at 50%	60	100	200	ns
T <sub>RDIO</sub>				15		ns
C <sub>IN</sub>	Input capacitance				10	pF

Symbol	Parameter	Condition	Min	Nom	Max	Unit
<b>Reset and Clock for card interface, RST, CLK</b>						
V <sub>OH</sub>	Output level, high	I <sub>OH</sub> = -200μA	0.9 V <sub>CC</sub>		V <sub>CC</sub>	V
V <sub>OL</sub>	Output level, low	I <sub>OL</sub> = 200μA	0		0.15 V <sub>CC</sub>	V
V <sub>INACT</sub>	Output voltage when outside of session	I <sub>OL</sub> = 0			0.1	V
		I <sub>OL</sub> = 1mA			0.3	V
I <sub>RST_LIM</sub>	Output current limit, RST				30	mA
I <sub>CLK_LIM</sub>	Output current limit, CLK				70	mA
CLK <sub>SR3V</sub>	CLK slew rate	V <sub>CC</sub> = 3V	0.3			V/ns
CLK <sub>SR5V</sub>	CLK slew rate	V <sub>CC</sub> = 5V	0.5			V/ns
t <sub>R</sub> , t <sub>F</sub>	Output rise time, fall time	C <sub>L</sub> = 35pF for CLK, 10% to 90%			8	ns
		C <sub>L</sub> = 200pF for RST, 10% to 90%			100	ns
δ	Duty cycle for CLK	C <sub>L</sub> = 35pF, F <sub>CLK</sub> ≤ 20MHz	45		55	%

## 2.5 Characteristics: Digital Signals

Table 6 lists the 73S8014R digital signals characteristics.

**Table 6: Digital Signals Characteristics**

Symbol	Parameter	Condition	Min	Nom	Max	Unit
<b>Digital I/O except for XTALIN and XTALOUT</b>						
V <sub>IL</sub>	Input Low Voltage		-0.3		0.8	V
V <sub>IH</sub>	Input High Voltage		1.8		V <sub>DD</sub> + 0.3	V
V <sub>OL</sub>	Output Low Voltage	I <sub>OL</sub> = 2mA			0.45	V
V <sub>OH</sub>	Output High Voltage	I <sub>OH</sub> = -1mA	V <sub>DD</sub> - 0.45			V
R <sub>OUT</sub>	Pull-up resistor, $\overline{\text{OFF}}$		16	20	24	kΩ
I <sub>IL1</sub>	Input Leakage Current	GND < V <sub>IN</sub> < V <sub>DD</sub>	-5		5	μA

Oscillator (XTALIN) I/O Parameters						
$V_{ILXTAL}$	Input Low Voltage - XTALIN		-0.3		$0.3 V_{DD}$	V
$V_{IHXTAL}$	Input High Voltage - XTALIN		$0.7 V_{DD}$		$V_{DD}+0.3$	V
$I_{ILXTAL}$	Input Current - XTALIN	$GND < V_{IN} < V_{DD}$	-30		30	$\mu A$
$f_{MAX}$	Max freq. Osc or external clock				27	MHz
$\delta_{in}$	External input duty cycle limit	$t_{R/F} < 10\% f_{IN}$ , $45\% < \delta_{CLK} < 55\%$	48		52	%

## 2.6 DC Characteristics

Table 7 lists the 73S8014R DC characteristics.

Table 7: DC Characteristics

Symbol	Parameter	Condition	Min	Nom	Max	Unit
$I_{DD}$	Supply Current	12 MHz XTAL		2.7	7.0	mA
		Ext CLK, $V_{DD} = 2.7 - 3.6V$ , VCC Off		1.7		mA
		Ext CLK, $V_{DD} = 2.7 - 3.6V$ , VCC On		2.2		mA
		Ext CLK, $V_{DD} = 4.5 - 5.5V$ , VCC Off		2.7		mA
		Ext CLK, $V_{DD} = 4.5 - 5.5V$ , VCC On		3		mA
$I_{PC}$	Supply Current	$V_{CC}$ on, $I_{CC}=0$ I/O, AUX1, AUX2=high, Clock not toggling		450	700	$\mu A$
$I_{PCOFF}$	$V_{PC}$ supply current when $V_{CC} = 0$	$\overline{CMDVCC}$ High		345	650	$\mu A$

## 2.7 Voltage Fault Detection Circuits

Table 8 lists the 73S8014R Voltage Fault Detection Circuits.

**Table 8: Voltage Fault Detection Circuits**

Symbol	Parameter	Condition	Min	Nom	Max	Unit
$V_{DDF}$	$V_{DD}$ fault ( $V_{DD}$ Voltage supervisor threshold)	No external resistor on $V_{DDF\_ADJ}$ pin	2.15		2.4	V
$V_{CCF}$	$V_{CC}$ fault ( $V_{CC}$ Voltage supervisor threshold)	$V_{CC} = 5v$			4.6	V
		$V_{CC} = 3v$			2.7	V

### 3 Applications Information

This section provides general usage information for the design and implementation of the 73S8014R. The documents listed in [Related Documentation](#) provide more detailed information.

#### 3.1 Example 73S8014R Schematics

[Figure 3](#) shows a typical application schematic for the implementation of the 73S8014R. Note that minor changes may occur to the reference material from time to time and the reader is encouraged to contact Teridian for the latest information.

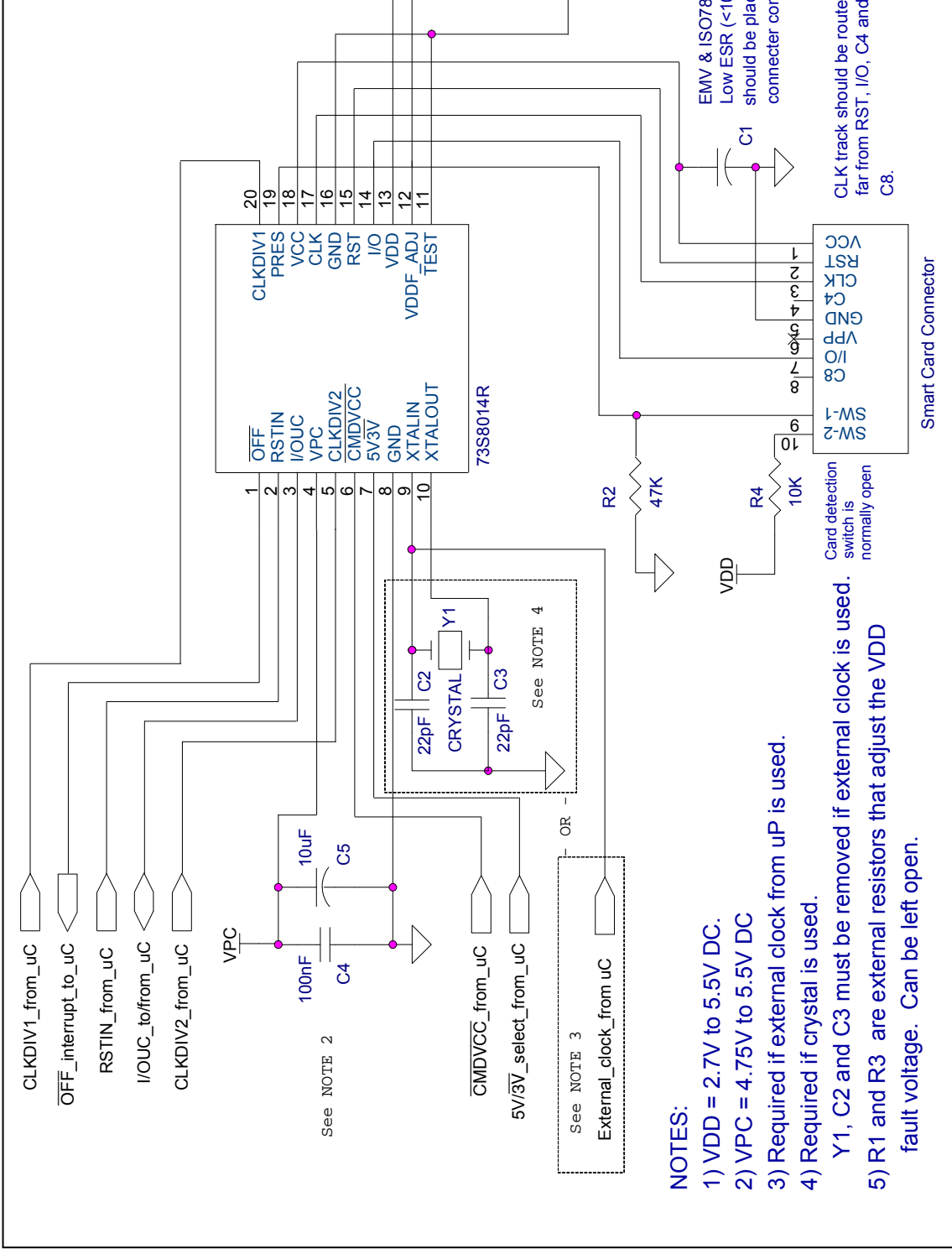

**NOTES:**

- 1) VDD = 2.7V to 5.5V DC.
- 2) VPC = 4.75V to 5.5V DC
- 3) Required if external clock from uP is used.
- 4) Required if crystal is used.
- 5) R1 and R3 are external resistors that adjust the VDD fault voltage. Can be left open.

**Figure 3: 73S8014R – Typical Application Schematic**

### 3.2 System Controller Interface

Three digital inputs allow direct control of the card interface by the host. The 73S8014R is controlled as follows:

- Pin  $\overline{\text{CMDVCC}}$ : When asserted low, starts an activation sequence
- Pin RSTIN: controls the card RST signal (when enabled by the sequencer)
- Pin  $5\text{V}/\overline{3\text{V}}$ : Defines the card VCC voltage (5V when high and 3V when low)

Card clock frequency can be controlled by 2 digital inputs:

- CLKDIV1 and CLKDIV2 define the division rate for the clock frequency, from the input clock frequency (crystal or external clock)

Note: The maximum CLK frequency is 20MHz. Therefore, if using an input clock source greater than 20MHz, a divisor rate of 2X or higher must be used.

Interrupt output to the host: As long as the card is not activated, the  $\overline{\text{OFF}}$  pin informs the host about the card presence only (Low = No card in the reader). When  $\overline{\text{CMDVCC}}$  is asserted low (Card activation sequence requested from the host), low level on  $\overline{\text{OFF}}$  means a fault has been detected (e.g. card removal during card session, voltage fault, or over-current fault) that automatically initiates a deactivation sequence.

### 3.3 Power Supply and Voltage Supervision

The 73S8014R smart card interface IC incorporates a LDO voltage regulator. The voltage output is controlled by the digital input  $5\text{V}/\overline{3\text{V}}$  of the 73S8014R. This regulator is able to provide either 3V or 5V card voltage from the power supply applied on the VPC pin. The voltage regulator can provide a current of at least 65mA on VCC for both 3V and 5V that complies with EMV 4.0.

Digital circuitry is powered by the power supply applied on the VDD pin. VDD also defines the voltage range to interface with the system controller. A card deactivation sequence is forced upon fault of any of this voltage supervisor. One voltage supervisor constantly monitors the VDD voltage. It is used to initialize the ISO 7816-3 sequencer at power-on, and to deactivate the card at power-off or upon fault. The voltage threshold of the VDD voltage supervisor is internally set by default to 2.33V nominal. However, it may be desirable, in some applications, to modify this threshold value. The pin VDDF\_ADJ is used to connect an external resistor  $R_{\text{EXT}}$  to ground to change the VDD fault voltage to another value,  $V_{\text{DDF}}$ . The resistor value is defined as follows:

$$R_{\text{EXT}} = 56\text{k}\Omega / (V_{\text{DDF}} - 2.33)$$

An alternative (more accurate) method of adjusting the VDD fault voltage is to use a resistive network of R3 from the pin to supply and R1 from the pin to ground (see [Figure 3](#)). In order to set the new threshold voltage, the equivalent resistance must be determined. This resistance value will be designated Kx. Kx is defined as  $R1/(R1+R3)$ . Kx is calculated as:

$$Kx = (2.789 / V_{\text{TH}}) - 0.6125 \text{ where } V_{\text{TH}} \text{ is the desired new threshold voltage.}$$

To determine the values of R1 and R3, use the following formulas.

$$R3 = 24000 / Kx \quad R1 = R3 * (Kx / (1 - Kx))$$

Taking the example above, where a  $V_{\text{DD}}$  fault threshold voltage of 2.7V is desired, solving for Kx gives:

$$\rightarrow Kx = (2.789 / 2.7) - 0.6125 = 0.42046.$$

Solving for R3 gives:  $\rightarrow R3 = 24000 / 0.42046 = 57080.$

Solving for R1 gives:  $\rightarrow R1 = 57080 * (0.42046 / (1 - 0.42046)) = 41412.$

Using standard 1 % resistor values gives  $R3 = 57.6\text{k}\Omega$  and  $R1 = 42.4\text{k}\Omega$ .

These values give an equivalent resistance of  $Kx = 0.4228$ , a 0.6% error.

If the 2.33V default threshold is used, this pin must be left unconnected.

### 3.4 Card Power Supply

The card power supply is internally provided by the LDO regulator, and controlled by the digital ISO 7816-3 sequencer. Card voltage selection on the 73S8014R is carried out by the digital input 5V/3V.

#### Choice of the VCC capacitor:

Depending on the application, the requirements in terms of both VCC minimum voltage and transient currents that the interface must be able to provide to the card are different. An external capacitor must be connected between the VCC pin and to the card ground in order to guarantee stability of the LDO regulator, and to handle the transient requirements. The type of capacitor should be an X5R/X7R with ERS<100 mΩ.

### 3.5 On-Chip Oscillator and Card Clock

The 73S8014R device has an on-chip oscillator that can generate the smart card clock using an external crystal (connected between the pins XTALIN and XTALOUT) to set the oscillator frequency. When the clock signal is available from another source, it can be connected to the pin XTALIN, and the pin XTALOUT should be left unconnected.

The card clock frequency may be chosen between 4 different division rates, defined by digital inputs CLKDIV 1 and CLKDIV 2, as per the following table:

CLKDIV1	CLKDIV2	CLK	Max XTALIN
0	0	1/8 XTALIN	27MHz
0	1	1/4 XTALIN	27MHz
1	0	XTALIN	20MHz
1	1	1/2 XTALIN	27MHz

### 3.6 Activation Sequence

The 73S8014R smart card interface ICs have an internal 10ms delay on the application of VDD where  $VDD > V_{DDF}$ . No activation is allowed during this 10ms period. The  $\overline{CMDVCC}$  (edge triggered) signal must then be set low to activate the card. In order to initiate activation, the card must be present; there can be no VDD fault.

The following steps show the activation sequence and the timing of the card control signals when the system controller sets  $\overline{CMDVCC}$  low while the RSTIN is low:

- $\overline{CMDVCC}$  is set low at  $t_0$ .
- VCC will rise to the selected level and then the internal VCC control circuit checks the presence of VCC at the end of  $t_1$ . In normal operation, the voltage VCC to the card becomes valid before  $t_1$ . If VCC is not valid at  $t_1$ , the  $\overline{OFF}$  goes low to report a fault to the system controller, and VCC to the card is shut off.
- Turn I/O to reception mode at  $t_2$ .
- CLK is applied to the card at  $t_3$ .
- RST is a copy of RSTIN after  $t_3$ .

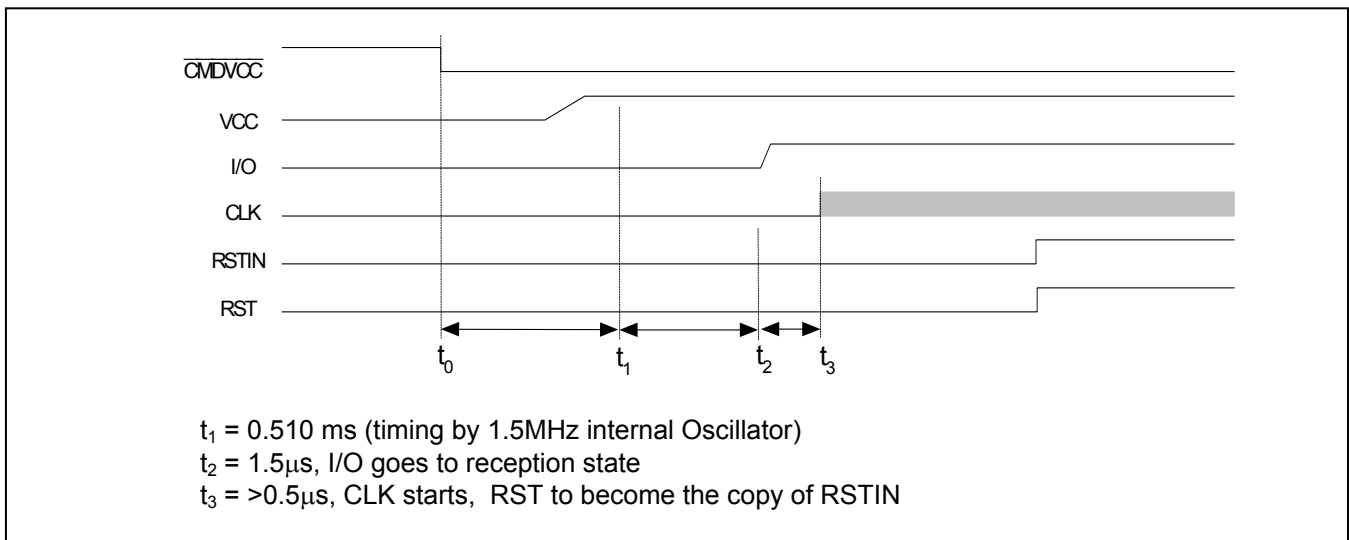

**Figure 4: Activation Sequence – RSTIN Low When  $\overline{CMDVCC}$  Goes Low**

The following steps show the activation sequence and the timing of the card control signals when the system controller pulls the  $\overline{CMDVCC}$  low while the RSTIN is high:

- $\overline{CMDVCC}$  is set low at  $t_0$ .
- VCC will rise to the selected level and then the internal VCC control circuit checks the presence of VCC at the end of  $t_1$ . In normal operation, the voltage VCC to the card becomes valid before  $t_1$ . If VCC is not valid at  $t_1$ , the  $\overline{OFF}$  goes low to report a fault to the system controller, and VCC to the card is shut off.
- At the fall of RSTIN at  $t_2$ , CLK is applied to the card
- RST is a copy of RSTIN after  $t_2$ .

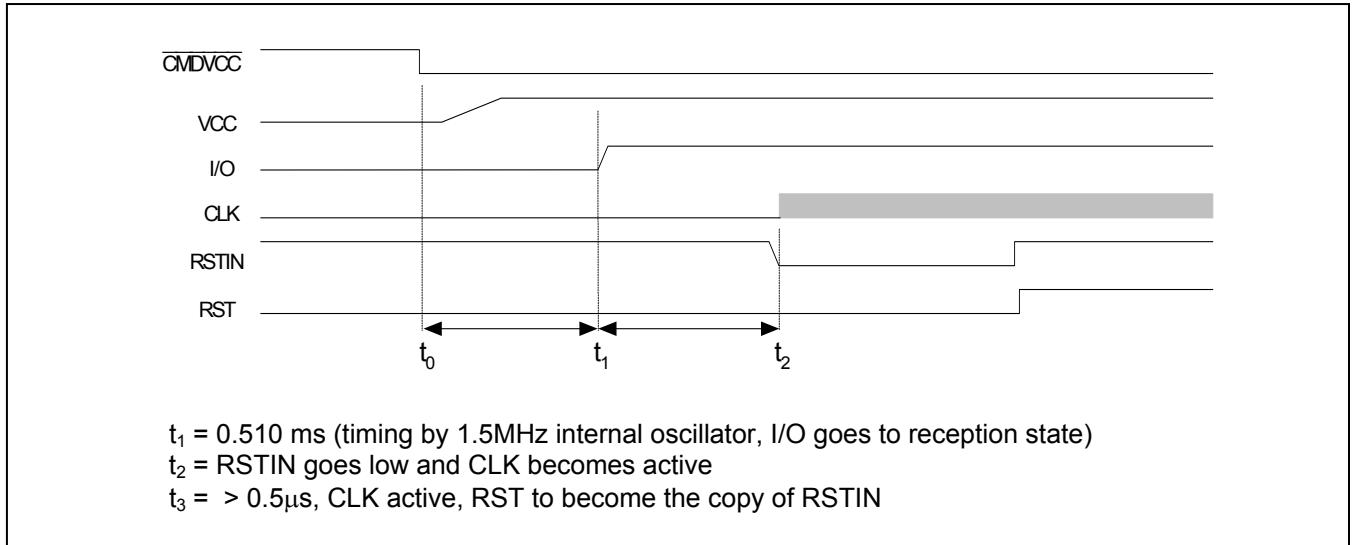

**Figure 5: Activation Sequence – RSTIN High When  $\overline{\text{CMDVCC}}$  Goes Low**

### 3.7 Deactivation Sequence

Deactivation is initiated either by the system controller by setting the  $\overline{\text{CMDVCC}}$  high, or automatically in the event of hardware faults. Hardware faults are over-current, VDD fault, VCC fault, and card extraction during the session.

The following steps show the deactivation sequence and the timing of the card control signals when the system controller sets the  $\overline{\text{CMDVCC}}$  high or OFF goes low due to a fault or card removal:

- RST goes low at the end of  $t_1$ .
- CLK is set low at the end of  $t_2$ .
- I/O goes low at the end of  $t_3$ . Out of reception mode.
- VCC is shut down at the end of time  $t_4$ . After a delay  $t_5$  (discharge of the VCC capacitor), VCC is low.

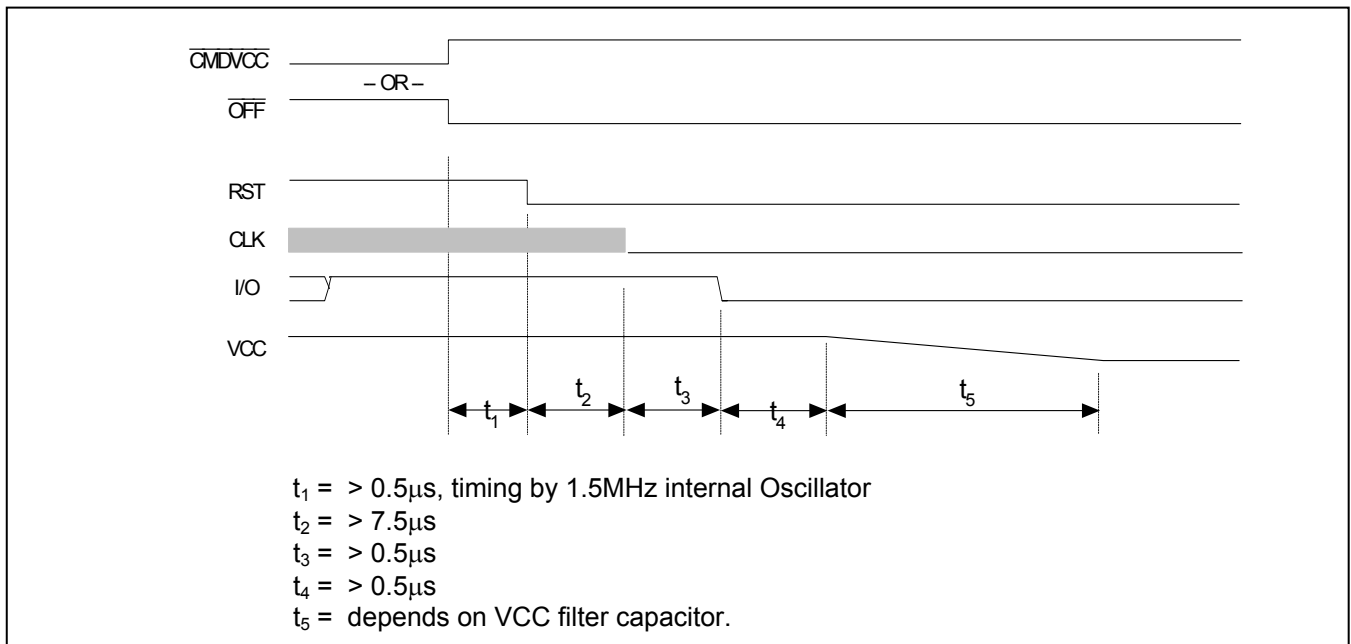

**Figure 6: Deactivation Sequence**

### 3.8 Fault Detection and $\overline{\text{OFF}}$

There are two different cases that the system controller can monitor the  $\overline{\text{OFF}}$  signal: to query regarding the card presence outside card sessions, or for fault detection during card sessions.

Outside a card session: In this condition,  $\overline{\text{CMDVCC}}$  is/are always high,  $\overline{\text{OFF}}$  is low if the card is not present, and high if the card is present. Because it is outside a card session, any fault detection will not act upon the  $\overline{\text{OFF}}$  signal. No deactivation is required during this time.

During a card session:  $\overline{\text{CMDVCC}}$  is/are always low, and  $\overline{\text{OFF}}$  falls low if the card is extracted or if any fault detection is detected. At the same time that  $\overline{\text{OFF}}$  is set low, the sequencer starts the deactivation process.

Figure 7 shows the timing diagram for the signals  $\overline{\text{CMDVCC}}$ , PRES, and  $\overline{\text{OFF}}$  during a card session and outside the card session:

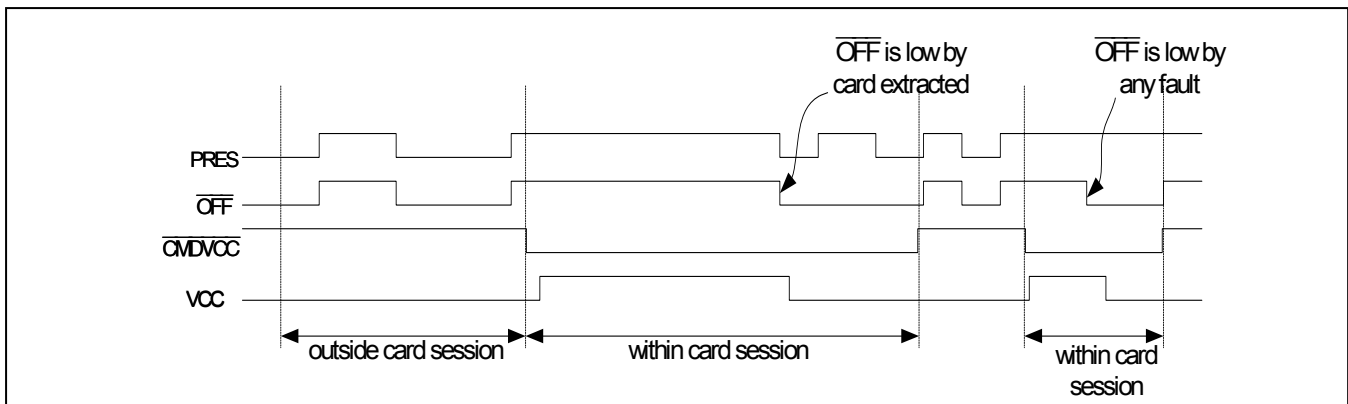

Figure 7: Timing Diagram – Management of the Interrupt Line  $\overline{\text{OFF}}$

### 3.9 I/O Circuitry and Timing

The state of the I/O pin is low after power on reset and it goes high when the activation sequencer turns on the I/O reception state. See the [Activation Sequence](#) section for details on when the I/O reception is enabled. The state of I/OUC is high after power on reset.

Within a card session and when the I/O reception state is turned on, the first I/O line on which a falling edge is detected becomes the input I/O line and the other becomes the output I/O line. When the input I/O line rising edge is detected then both I/O lines return to their neutral state.

Figure 8 shows the state diagram of how the I/O and I/OUC lines are managed to become input or output. The delay between the I/O signals is shown in Figure 9.

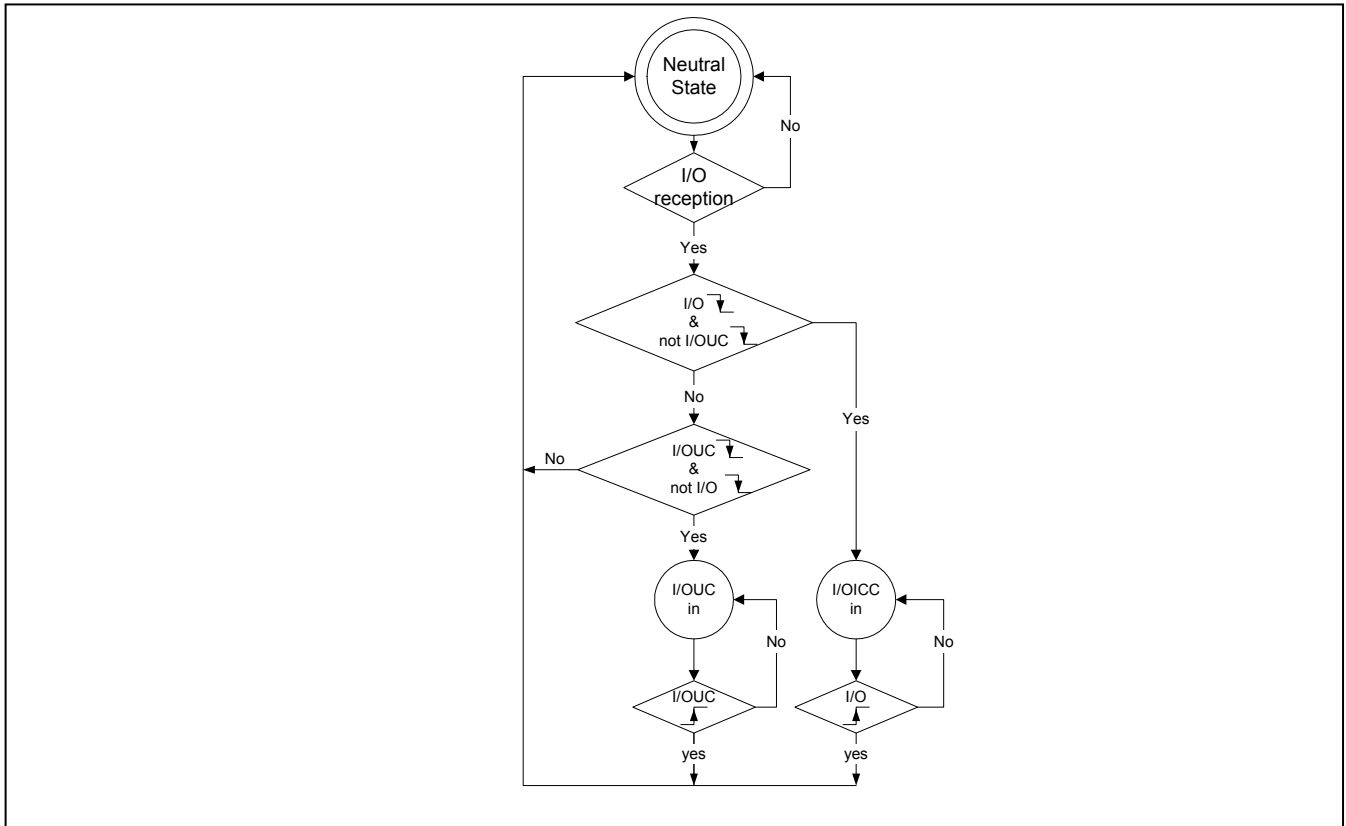

Figure 8: I/O and I/OUC State Diagram

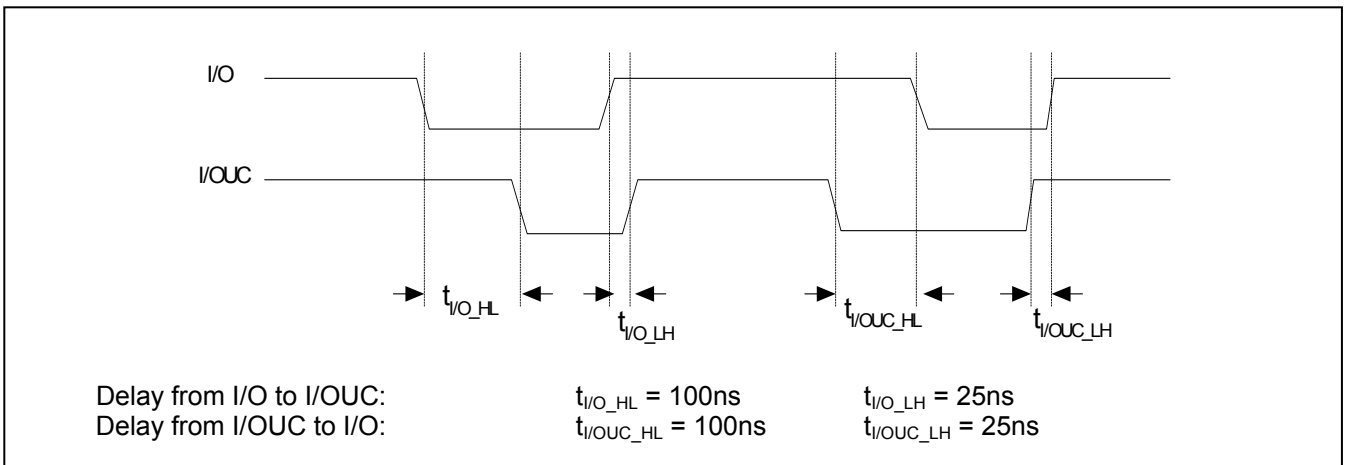

Figure 9: I/O - I/OUC Delays - Timing Diagram

### 4 Equivalent Circuits

This section provides illustrations of circuits equivalent to those described in the pinout section.

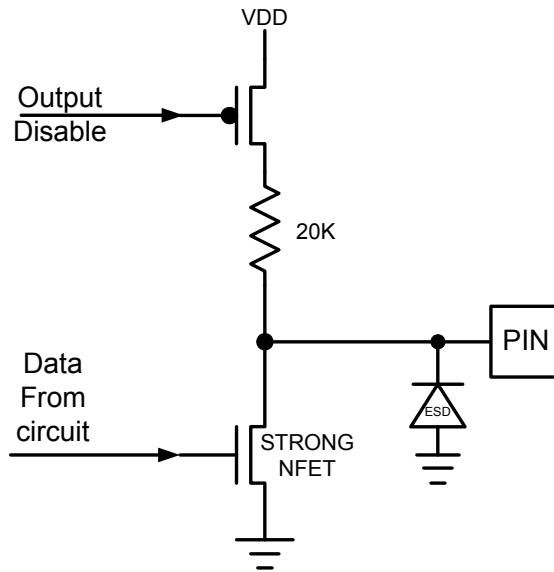

Figure 10: Open Drain type –  $\overline{\text{OFF}}$

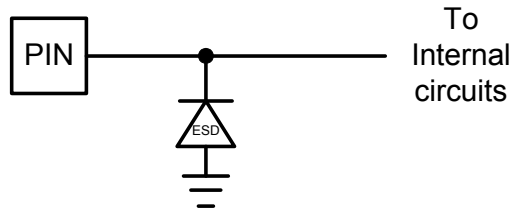

Figure 11: Power Input/Output Circuit, VDD, VPC, VCC

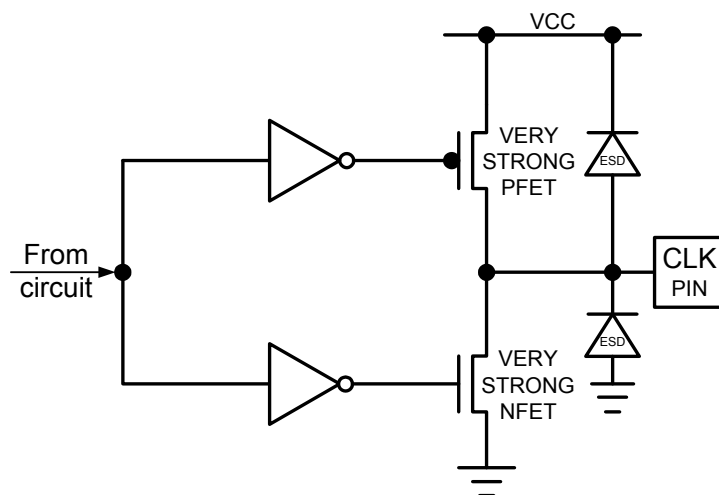

Figure 12: Smart Card CLK Driver Circuit

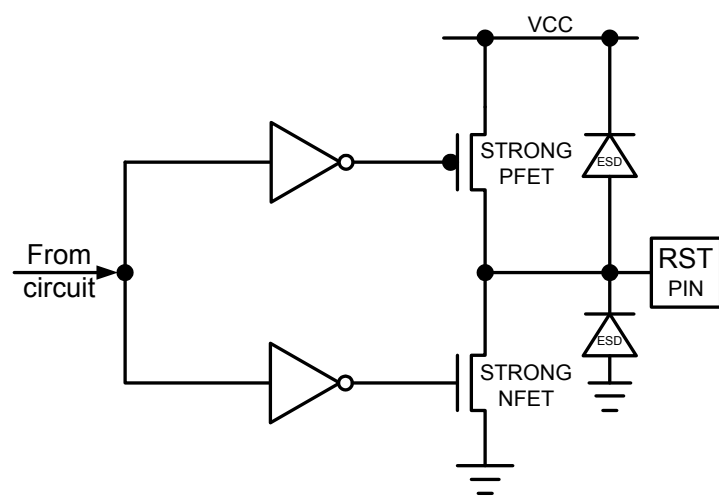

Figure 13: Smart Card RST Driver Circuit

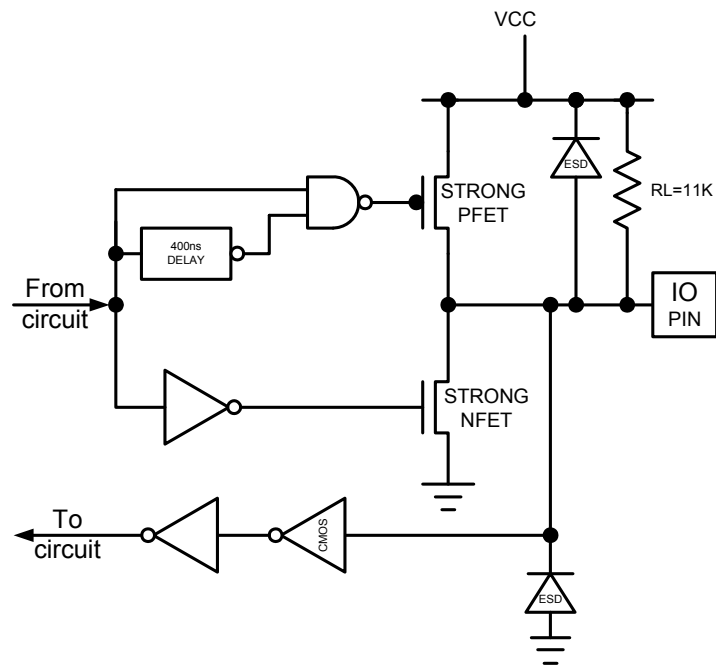

Figure 14: Smart Card IO Interface Circuit

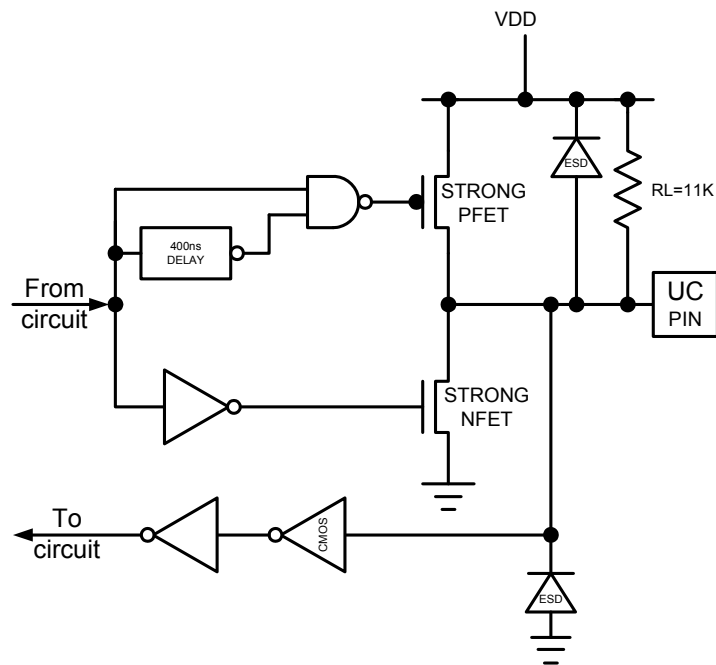
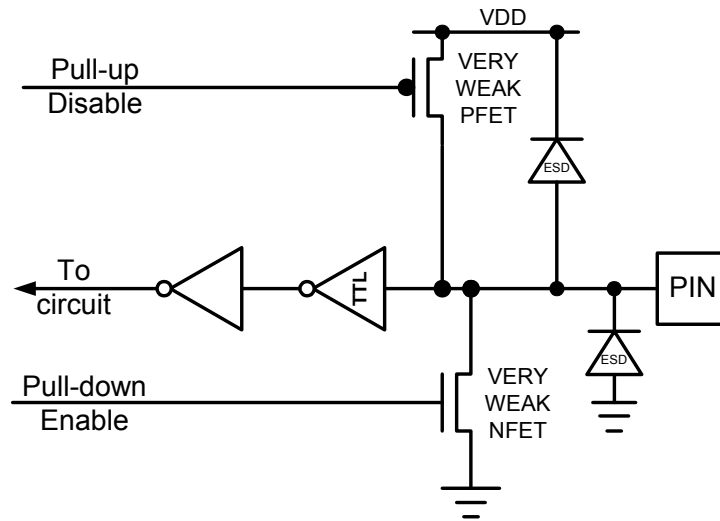

Figure 15: Smart Card IOUC Interface Circuit



Note: Pins  $\overline{\text{CMDVCC}}, 5\text{V}/3\overline{\text{V}}$ , CLKDIV1 and CLKDIV2 have the pull-up enabled.  
 Pins RSTIN, CLKIN, PRES have the pull-down enabled.

Figure 16: General Input Circuit

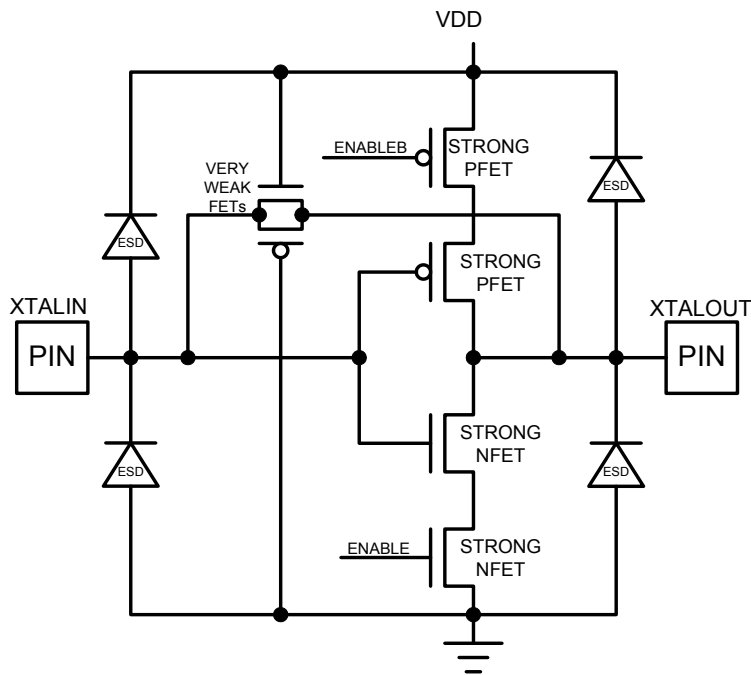

Figure 17: Oscillator Circuit

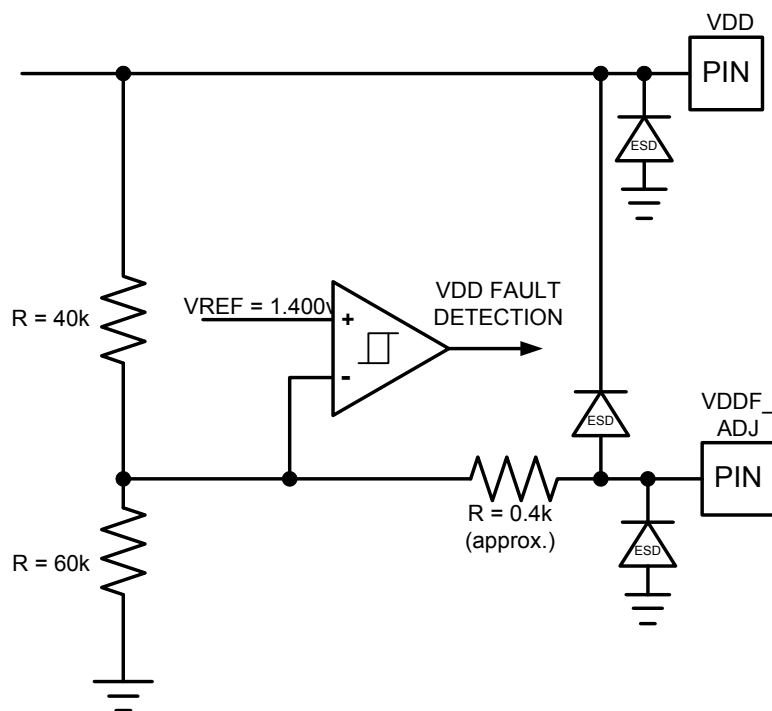

Figure 18: VDDF\_ADJ

### 5 Mechanical Drawing

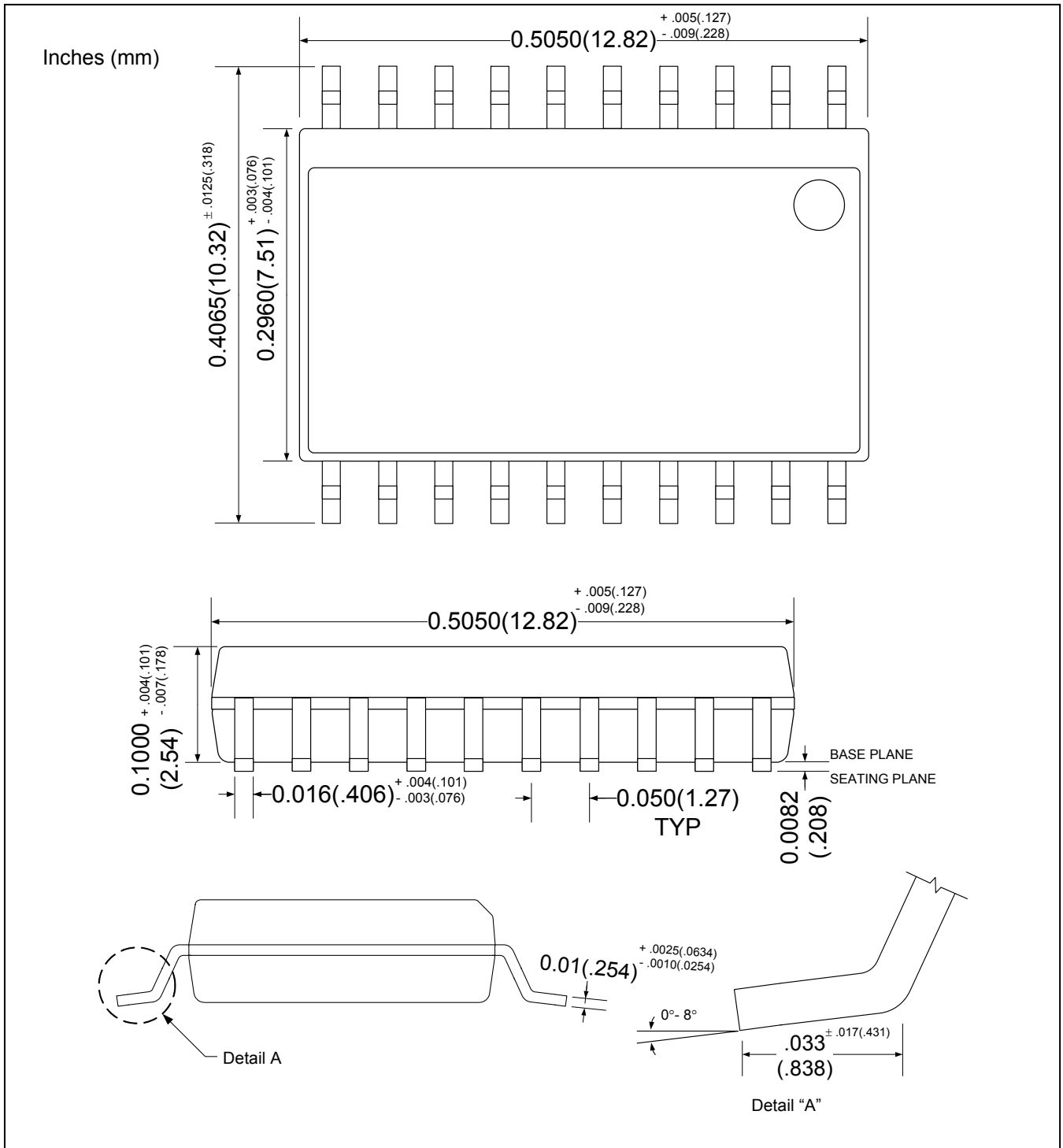

Figure 19: Mechanical Drawing 20-Pin SO Package

## 6 Ordering Information

Table 9 lists the order numbers and packaging marks used to identify 73S8014R products.

**Table 9: Order Numbers and Packaging Marks**

Part Description	Order Number	Packaging Mark
73S8014R 20-pin Lead-Free	73S8014R-IL/F	73S8014R
73S8014R 20-pin Lead-Free Tape / Reel	73S8014R-ILR/F	73S8014R

## 7 Related Documentation

The following 73S8014R document is available from Teridian Semiconductor Corporation:

*73S8014R/RN/RT 20SO Demo Board User Manual*

## 8 Contact Information

For more information about Teridian Semiconductor products or to check the availability of the 73S8014R, contact us at:

6440 Oak Canyon Road  
Irvine, CA 92618-5201

Telephone: (714) 508-8800  
FAX: (714) 508-8878  
Email: [scr.support@teridian.com](mailto:scr.support@teridian.com)

For a complete list of worldwide sales offices, go to <http://www.teridian.com>.

**Revision History**

<b>Revision</b>	<b>Date</b>	<b>Description</b>
1.0	9/3/2008	First publication.

© 2008 Teridian Semiconductor Corporation. All rights reserved.  
Teridian Semiconductor Corporation is a registered trademark of Teridian Semiconductor Corporation.  
Simplifying System Integration is a trademark of Teridian Semiconductor Corporation.  
All other trademarks are the property of their respective owners.

Teridian Semiconductor Corporation makes no warranty for the use of its products, other than expressly contained in the Company's warranty detailed in the Teridian Semiconductor Corporation standard Terms and Conditions. The company assumes no responsibility for any errors which may appear in this document, reserves the right to change devices or specifications detailed herein at any time without notice and does not make any commitment to update the information contained herein. Accordingly, the reader is cautioned to verify that this document is current by comparing it to the latest version on <http://www.teridian.com> or by checking with your sales representative.

Teridian Semiconductor Corp., 6440 Oak Canyon Rd., Suite 100, Irvine, CA 92618  
TEL (714) 508-8800, FAX (714) 508-8877, <http://www.Teridian.com>

## Looking for pricing, stock, or lifecycle information?

Click below to explore more details on WIN SOURCE:

[View 73S8014R-ILR/F on WIN SOURCE](#)

[Maxim Integrated Information](#)

## Optimize Your Supply Chain with WIN SOURCE Solutions

- ✓ Global Sourcing Solution
- ✓ Obsolete Management
- ✓ Cost Control Management
- ✓ Shortage Management
- ✓ Alternative Solution
- ✓ Excess Inventory Management