



**THE DATASHEET OF  
71M6533H-IGT/F**





# 71M6533-DB Demo Board

## USER'S MANUAL

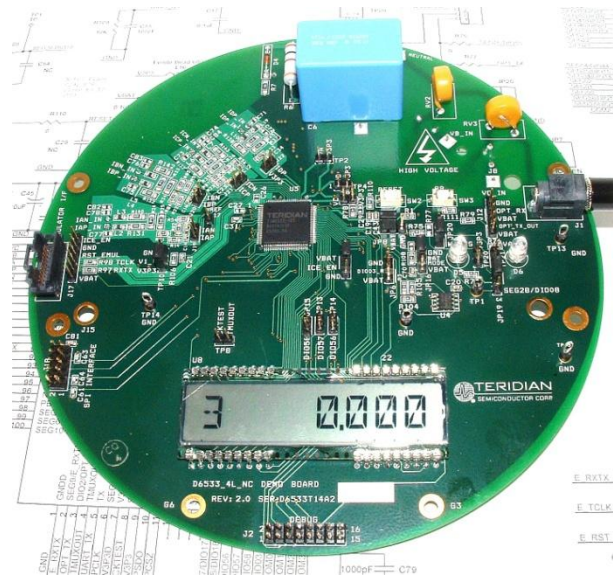



# 71M6533

3-Phase Energy Meter IC

DEMO BOARD 71M6533-DB

## USER'S MANUAL

*Maxim cannot assume responsibility for use of any circuitry other than circuitry entirely embodied in a Maxim product. No circuit patent licenses are implied. Maxim reserves the right to change the circuitry and specifications without notice at any time.*

**Maxim Integrated Products, Inc. 160 Rio Robles, San Jose, CA 95134 USA 1-408-601-1000**

# Table of Contents

<b>1</b>	<b>GETTING STARTED.....</b>	<b>7</b>
1.1	General.....	7
1.2	Safety and ESD Notes.....	7
1.3	Demo Kit Contents.....	7
1.4	Demo Board Versions.....	7
1.5	Compatibility.....	8
1.6	Suggested Equipment not Included.....	8
1.7	Demo Board Test Setup.....	8
1.7.1	Setup with USB-to-Serial Adapter.....	9
1.7.2	Power Supply Setup.....	10
1.7.3	Checking Operation.....	10
1.7.4	Serial Connection Setup.....	11
1.8	Using the Demo Board.....	13
1.8.1	Serial Command Language.....	13
1.8.2	Using the Demo Board for Energy Measurements.....	21
1.8.3	Adjusting the Kh Factor for the Demo Board.....	21
1.8.4	Adjusting the Demo Boards to Different Current Transformers.....	21
1.8.5	Adjusting the Demo Boards to Different Voltage Dividers.....	22
1.9	Calibration Parameters.....	23
1.9.1	General Calibration Procedure.....	23
1.9.2	Calibration Macro File.....	24
1.9.3	Updating the Demo Code (hex file).....	24
1.9.4	Updating Calibration Data in Flash or EEPROM.....	24
1.9.5	Automatic Gains Calibration.....	25
1.9.6	Loading the Code for the 6533 into the Demo Board.....	25
1.9.7	The Programming Interface of the 71M6533.....	27
1.10	Demo Code.....	27
1.10.1	Demo Code Description.....	27
1.10.2	Important Demo Code MPU Parameters.....	27
1.10.3	Useful CLI Commands Involving the MPU and CE.....	33
<b>2</b>	<b>APPLICATION INFORMATION.....</b>	<b>35</b>
2.1	Calibration Theory.....	35
2.1.1	Calibration with Three Measurements.....	35
2.1.2	Calibration with Five Measurements.....	37
2.2	Calibration Procedures.....	38
2.2.1	Calibration Procedure with Three Measurements.....	39
2.2.2	Calibration Procedure with Five Measurements.....	40
2.2.3	Calibration Procedure for Rogowski Coil Sensors.....	40
2.2.4	Calibration Spreadsheets.....	41
2.2.5	Compensating for Non-Linearities.....	45
2.3	Power Saving Measures.....	46
2.4	Schematic Information.....	46
2.4.1	Components for the V1 Pin.....	46
2.4.2	Reset Circuit.....	46
2.4.3	Oscillator.....	47
2.4.4	EEPROM.....	47
2.4.5	LCD.....	48
2.4.6	Optical Interface.....	48
2.4.7	Ferrites.....	49

<b>2.5</b>	<b>Testing the Demo Board</b> .....	<b>49</b>
2.5.1	Functional Meter Test.....	49
2.5.2	EEPROM.....	51
2.5.3	RTC.....	51
2.5.4	Hardware Watchdog Timer .....	52
2.5.5	LCD.....	52
<b>2.6</b>	<b>Application Notes</b> .....	<b>53</b>
<b>3</b>	<b>HARDWARE DESCRIPTION</b> .....	<b>55</b>
<b>3.1</b>	<b>71M6533 Board Description: Jumpers, Switches and Test Points</b> .....	<b>55</b>
<b>3.2</b>	<b>Board Hardware Specifications</b> .....	<b>58</b>
<b>4</b>	<b>APPENDIX</b> .....	<b>59</b>
<b>4.1</b>	<b>71M6533-DB Demo Board Electrical Schematic</b> .....	<b>60</b>
<b>4.2</b>	<b>71M6533-DB Demo Board Bill of Material</b> .....	<b>63</b>
<b>4.3</b>	<b>71M6533-DB Demo Board PCB Layout</b> .....	<b>64</b>
<b>4.4</b>	<b>71M6533 Pin-Out Information</b> .....	<b>70</b>
<b>5</b>	<b>REVISION HISTORY</b> .....	<b>75</b>

## List of Figures

Figure 1-1:	Block Diagram for the 71M6533-DB Demo Board with Debug Board.....	9
Figure 1-2:	DB6534T14A3 Demo Board with USB-to-Serial Adapter.....	10
Figure 1-3:	Hyperterminal Sample Window with Disconnect Button (Arrow).....	12
Figure 1-4:	Port Speed and Handshake Setup (left) and Port Bit setup (right).....	12
Figure 1-5:	Command Line Help Display .....	13
Figure 1-6:	Typical Calibration Macro File.....	24
Figure 1-7:	Emulator Window Showing Reset and Erase Buttons (see Arrows) .....	26
Figure 1-8:	Emulator Window Showing Erased Flash Memory and File Load Menu.....	26
Figure 2-1:	Watt Meter with Gain and Phase Errors.....	35
Figure 2-2:	Phase Angle Definitions.....	39
Figure 2-3:	Calibration Spreadsheet for Three Measurements .....	42
Figure 2-4:	Calibration Spreadsheet for Five Measurements.....	43
Figure 2-5:	Calibration Spreadsheet for Rogowski coil .....	44
Figure 2-6:	Non-Linearity Caused by Quantification Noise .....	45
Figure 2-7:	Voltage Divider for V1 .....	46
Figure 2-8:	External Components for RESETZ .....	47
Figure 2-9:	Oscillator Circuit.....	47
Figure 2-10:	EEPROM Circuit .....	48
Figure 2-11:	LCD Connections.....	48
Figure 2-12:	Optical Interface Block Diagram .....	49
Figure 2-13:	Meter with Calibration System .....	50
Figure 2-14:	Calibration System Screen .....	50
Figure 2-15:	Wh Load Line in Differential Mode at Room Temperature .....	51
Figure 3-1:	71M6533-DB Demo Board - Board Description.....	57
Figure 4-1:	71M6533-DB Demo Board: Electrical Schematic 1/3.....	60
Figure 4-2:	71M6533-DB Demo Board: Electrical Schematic 2/3.....	61
Figure 4-3:	71M6533-DB Demo Board: Electrical Schematic 3/3.....	62
Figure 4-4:	71M6533-DB Demo Board: Top View.....	64
Figure 4-5:	71M6533-DB Demo Board: Top Copper.....	65
Figure 4-6:	71M6533-DB Demo Board: Middle Layer 1 (Ground Plane).....	66
Figure 4-7:	71M6533-DB Demo Board: Middle Layer 2 (Supply Plane).....	67
Figure 4-8:	71M6533-DB Demo Board: Bottom Copper.....	68
Figure 4-9:	71M6533-DB Demo Board: Bottom View.....	69
Figure 4-10:	71M6533/71M6533H epLQFP100: Pin Out (top view).....	73

## List of Tables

Table 1-1: Selectable Display Options .....	11
Table 1-2: CE RAM Locations for Calibration Constants .....	23
Table 1-3: Flash Programming Interface Signals .....	27
Table 1-4: MPU Input Parameters for Metering.....	29
Table 1-5: Selectable Pulse Sources .....	30
Table 1-6: MPU Instantaneous Output Variables .....	30
Table 1-7: MPU Status Word Bit Assignment .....	32
Table 1-8: MPU Accumulation Output Variables .....	33
Table 1-9: CLI Commands for Data Memory .....	33
Table 2-1: Power Saving Measures .....	46
Table 3-1: 71M6533-DB Demo Board Description .....	55
Table 3-2: 71M6533-DB Demo Board Description .....	56
Table 3-3: 71M6533-DB Demo Board Description .....	57
Table 4-1: 71M6533-DB Demo Board: Bill of Material .....	63
Table 4-2: 71M6533/71M6533H Pin Description Table 1/3.....	70
Table 4-3: 71M6533/71M6533H Pin Description Table 2/3.....	70
Table 4-4: 71M6533/71M6533H Pin Description Table 3/3.....	72



## 1

# 1 GETTING STARTED

## 1.1 GENERAL

The Teridian™ 71M6533-DB Demo Board is a demonstration board for evaluating the 71M6533 device for 3-phase electronic power metering applications. It incorporates a 71M6533 integrated circuit, peripheral circuitry such as a serial EEPROM, emulator port, and on-board power supply as well as a USB-to-serial adapter that allows a connection to a PC through the USB port. The demo board allows the evaluation of the 71M6533 energy meter chip for measurement accuracy and overall system use.

The board is pre-programmed with a demo program in the flash memory of the 71M6533 IC. This embedded application is developed to exercise all low-level function calls to directly manage the peripherals, flash programming, and CPU (clock, timing, power savings, etc.).

The 71M6533 IC on the demo board is pre-programmed with default calibration factors. Since current sensors are not part of the Demo Kit, the demo board is tested but not calibrated at the factory.

## 1.2 SAFETY AND ESD NOTES

Connecting live voltages to the demo board system will result in potentially hazardous voltages on the demo board.



**THE DEMO SYSTEM IS ESD SENSITIVE! ESD PRECAUTIONS SHOULD BE TAKEN WHEN HANDLING THE DEMO BOARD!**



**EXTREME CAUTION SHOULD BE TAKEN WHEN HANDLING THE DEMO BOARD ONCE IT IS CONNECTED TO LIVE VOLTAGES!**

## 1.3 DEMO KIT CONTENTS

- 71M6533-DB Demo Board with 71M6533F IC and Pre-Loaded Demo Program
- USB-to-Serial Adapter
- 5VDC/1000mA Universal Wall Transformer with 2.5mm Plug (Switchcraft 712A Compatible)
- USB Cable

## 1.4 DEMO BOARD VERSIONS

Currently, only the following version of the Demo Board is available:

- 71M6533-DB Demo Board (REV 3.0, standard)

*Teridian is a trademark of Maxim Integrated Products, Inc.*

## 1.5 COMPATIBILITY

This manual applies to the following hardware and software revisions:

- 71M6533 or 71M6533H chip revision A03
- Demo Kit firmware revision 4.p6q or later
- 71M6533-DB Demo Board REV 3.0

## 1.6 SUGGESTED EQUIPMENT NOT INCLUDED

For functional demonstration:

- PC with Microsoft Windows® operating systems: Windows XP®, Windows ME, or Windows 2000, equipped with RS232 port (COM port) via DB9 connector

For software development (MPU code):

- Signum ICE (In Circuit Emulator): ADM-51

<http://www.signum.com>

- Keil 8051 "C" Compiler kit: CA51

[www.keil.com/c51/ca51kit.htm](http://www.keil.com/c51/ca51kit.htm), [www.keil.com/product/sales](http://www.keil.com/product/sales)

## 1.7 DEMO BOARD TEST SETUP

The 71M6533-DB Demo Board block diagram is shown in Figure 1-1. The configuration consists of a stand-alone (round) meter Demo Board and an optional Debug Board. The Demo Board contains all circuits necessary for operation as a meter, including display, calibration LEDs, and internal power supply. The optional Debug Board, uses a separate power supply, and is optically isolated from the Demo Board. It interfaces to a PC through a 9 pin serial port connector. For serial communication between the PC and the 71M6533, the Debug Board needs to be plugged with its connector J3 into connector J2 of the Demo Board.

The USB-Serial Adapter allows communication between the 71M6533-DB Demo Board and a PC via its USB port.

Connections to the external signals to be measured, i.e. scaled AC voltages and current signals derived from shunt resistors or from current transformers, are provided on the rear side of the demo board.

**Caution: It is recommended to set up the demo board with no live AC voltage connected, and to connect live AC voltages only after the user is familiar with the demo system.**



**All input signals are referenced to the V3P3A (3.3V power supply to the chip).**

*Windows and Windows XP are registered trademarks of Microsoft Corp.*

# DEMONSTRATION METER

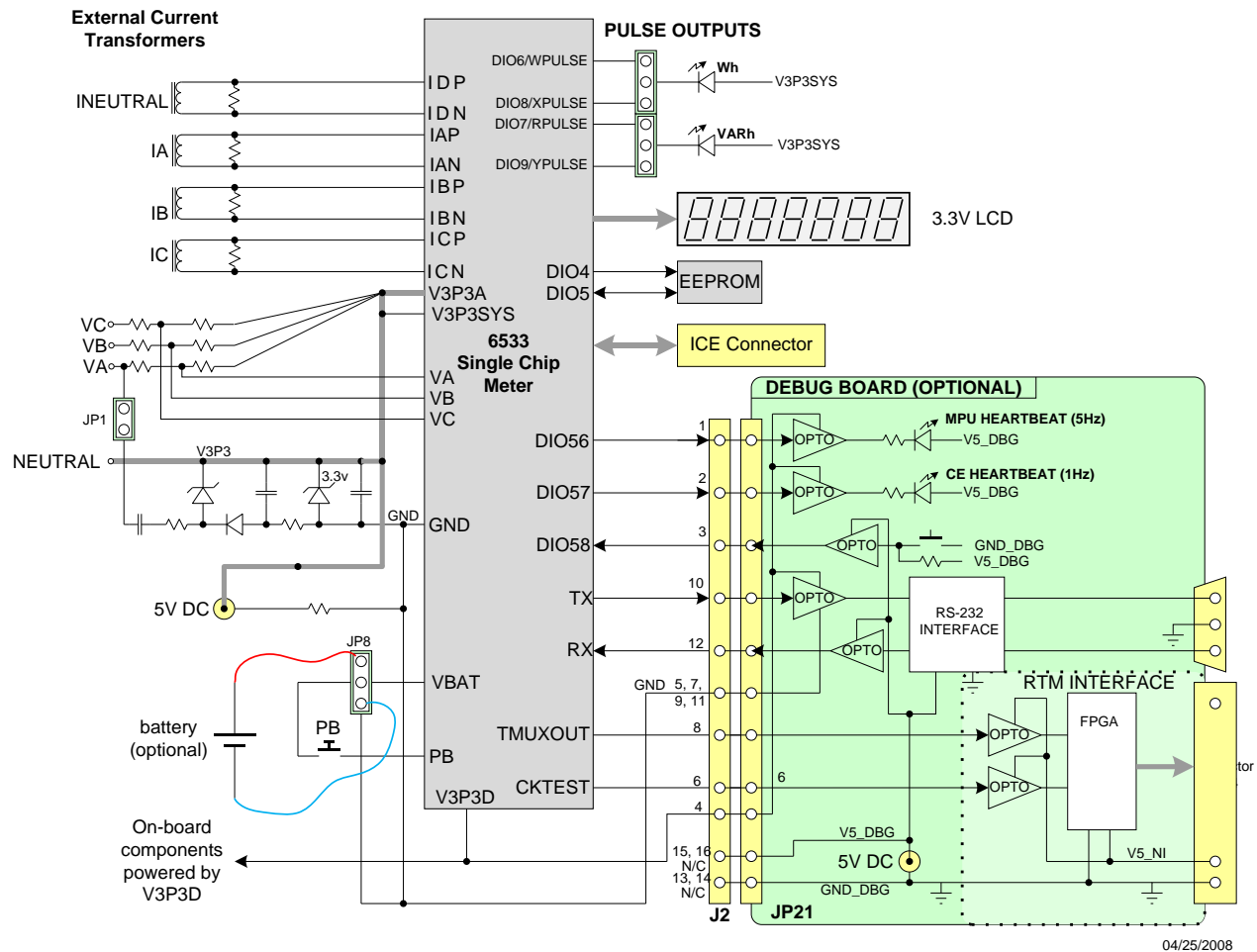

Figure 1-1: Block Diagram for the 71M6533-DB Demo Board with Debug Board

## 1.7.1 SETUP WITH USB-TO-SERIAL ADAPTER

The USB-to-Serial Adapter shipped with Demo Kits starting in June 2011 provides a connection to the Demo Board via USB. The USB-to-Serial Adapter is plugged into connector J2 of the DB6533 as shown in Figure 1-2.

The PC should be running HyperTerminal or a similar serial interface program. A suitable driver, e.g. the FTDI CDM Driver Package, must be installed on the PC to enable the USB port to be mapped as a virtual COM port. The driver can be found on the FTDI web site (<http://www.ftdichip.com/Drivers/D2XX.htm>).

The USB-to-Serial Adapter is self-powered via the USB port on the PC.

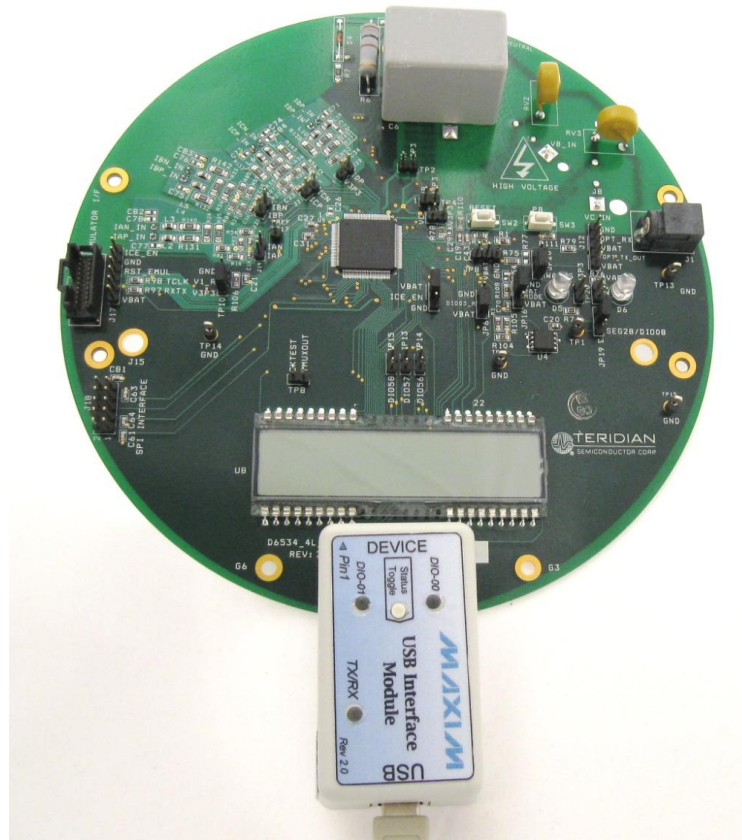

Figure 1-2: DB6534T14A3 Demo Board with USB-to-Serial Adapter

### 1.7.2 POWER SUPPLY SETUP

There are several choices for the meter power supply:

- Internal (using phase A of the AC line voltage). The internal power supply is only suitable when the phase A voltage exceeds 220V RMS. A jumper needs to be installed across JP1 on the bottom of the board.
- External 5VDC connector (J1) on the Demo Board.

### 1.7.3 CHECKING OPERATION

A few seconds after power up, the LCD display on the Demo Board should display this brief greeting:

		H	E	L	L	O	
--	--	---	---	---	---	---	--

The “HELLO” message should be followed by the display of accumulated energy:

3.				0.	0	0	1
----	--	--	--	----	---	---	---

The Wh display should be followed by the text “Wh”, as shown below:

3.			W	h			
----	--	--	---	---	--	--	--

The decimal dot in the rightmost segment will be blinking, indicating activity of the MPU inside the 71M6533.

The Demo Code allows cycling of the display using the PB button. By briefly pressing this button, the next available parameter from Table 1-1 is selected. This makes it easy to navigate various displays for Demo Boards without having to use the command line interface (CLI).

Step	Display in left-most digit(s)	Text display	Corresponding CLI command	Displayed Parameter
1	1	<b>Delt C</b>	<b>M1</b>	Temperature difference from calibration temperature. Displayed in 0.1°C
2	2	<b>HZ</b>	<b>M2</b>	Frequency at the VA_IN input [Hz]
3	3	<b>Wh</b>	<b>M3</b>	Accumulated real energy [Wh]. The default display setting after power-up or reset.
4	4	<b>Wh</b>	<b>M4</b>	Accumulated exported real energy [Wh].
5	5	<b>VARh</b>	<b>M5</b>	Accumulated reactive energy [VARh].
6	6	<b>VARh</b>	<b>M6</b>	Accumulated exported reactive energy [VARh].
7	7	<b>VAh</b>	<b>M7</b>	Accumulated apparent energy [VAh].
8	8	<b>HOURS</b>	<b>M8</b>	Elapsed time
9	9	<b>TIME</b>	<b>M9</b>	Time of day (hh.mm.ss)
10	--	<b>DATE</b>	<b>M10</b>	Date (yyyy.mm.dd)
11	11	<b>PF</b>	<b>M11</b>	Power factor
12	12	--	<b>M12</b>	V/V phase angle [degrees]
13	13	<b>EDGES</b>	<b>M13</b>	Zero crossings of the mains voltage
14	14	<b>PULSES</b>	<b>M14</b>	Pulse counter
15	15	<b>A</b>	<b>M15</b>	RMS current
16	16	<b>V</b>	<b>M16</b>	RMS voltage
17	17	<b>BAT V</b>	<b>M17</b>	Battery voltage

Table 1-1: Selectable Display Options

## 1.7.4 SERIAL CONNECTION SETUP

After connecting the DB9 serial port to a PC, start the HyperTerminal application and create a session using the following parameters:

**Port Speed: 9600 bd or 300bd (see below)**

**Data Bits: 8**

**Parity: None**

**Stop Bits: 1**

**Flow Control: XON/XOFF**

See section 3.1 for proper selection of the operation mode when main power is removed:

- A jumper across pins 2-3 (VBAT-GND) of JP16 indicates that no external battery is available. The IC will stay in brownout mode when the system power is down and it will communicate at **9600bd**.
- A jumper across pins 1-2 (BATMODE-VBAT) indicates that an external battery is available. The IC will be able to transition from brownout mode to sleep and LCD modes when the system power is down and it will communicate at **300bd**.

HyperTerminal can be found by selecting Programs → Accessories → Communications from the Windows® start menu. The connection parameters are configured by selecting File → Properties and then by pressing the

Configure button. Port speed and flow control are configured under the General tab (Figure 1-4, left), bit settings are configured by pressing the Configure button (Figure 1-4, right), as shown below. A setup file (file name "Demo Board Connection.ht") for HyperTerminal that can be loaded with File → Open is also provided with the tools and utilities.



Port parameters can only be adjusted when the connection is not active. The disconnect button, as shown in Figure 1-3 must be clicked in order to disconnect the port.

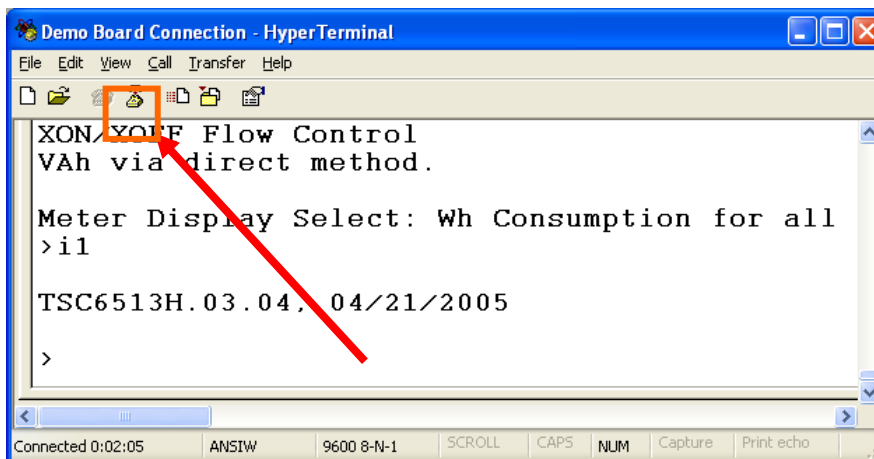

Figure 1-3: Hyperterminal Sample Window with Disconnect Button (Arrow)

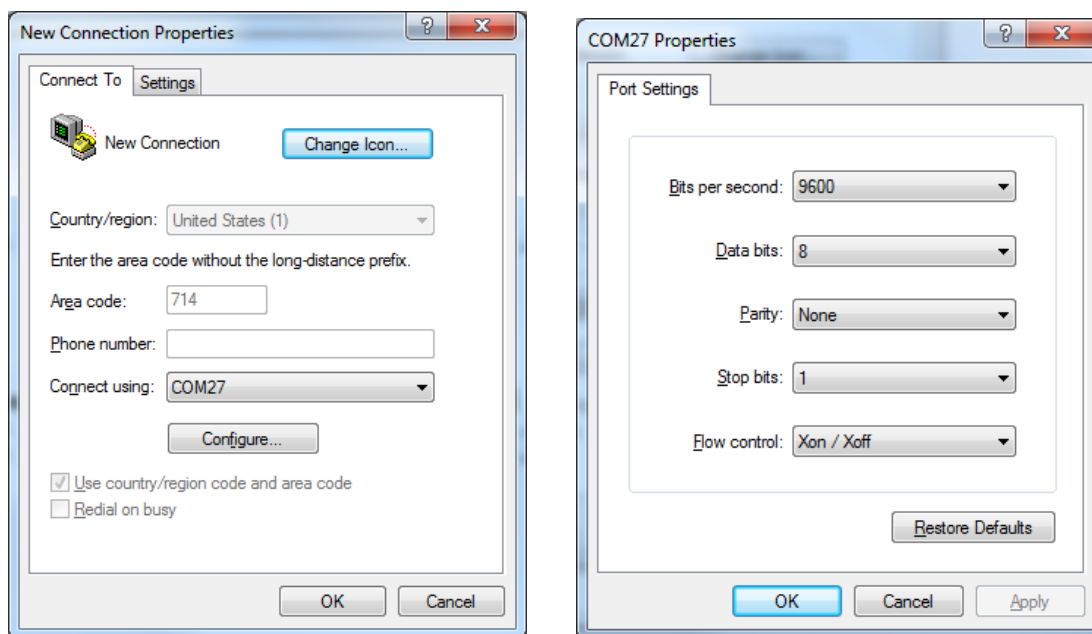

Figure 1-4: Port Speed and Handshake Setup (left) and Port Bit setup (right)

Once, the connection to the demo board is established, press <CR> and the command prompt, >, should appear. Type >? to see the **Demo Code** help menu. Type >i to verify the demo code revision.

## 1.8 USING THE DEMO BOARD

The 71M6533-DB Demo Board is a ready-to-use meter prepared for use with external current transformers (CTs).

Using the Demo Board involves communicating with the Demo Code via the command line interface (CLI). The CLI allows all sorts of manipulations to the metering parameters, access to the EEPROM, initiation of auto-cal sequences, selection of the displayed parameters, changing calibration factors and many more operations.

Before evaluating the 71M6533 on the Demo Board, users should get familiar with the commands and responses of the CLI. A complete description of the CLI is provided in section 1.8.1.

### 1.8.1 SERIAL COMMAND LANGUAGE

The Demo Code residing in the flash memory of the 71M6533 provides a convenient way of examining and modifying key meter parameters. Once the Demo Board is connected to a PC or terminal per the instructions given in Section **Error! Reference source not found.** and 1.7.4, typing '?' will bring up the list of commands shown in Figure 1-5.

```

?? : Command Line Interpreter On-line help
Usage: ?<char> or ?? to get this help page
Where <char> is an uppercase letter of the command.
The following commands/<char> are available:
. - Repeat last command      : / - Ignore rest of line
] - Access CE Data RAM      : ) - Access MPU Data RAM
C - Control metering        : I - Information message
M - Meter Display Control   : PS - Power Save
R - SFR and I/O Control     : RT - RTC Control
T - Trim Controls          : W - Wait for watchdog reset
Z - Soft reset
B - Battery mode commands
EE - EEPROM Control
ER - Error Recording
/ - Rest of line is a comment

For Example: ?C to get help on Compute Engine Control.
>_

```

Figure 1-5: Command Line Help Display

The tables in this chapter describe the commands in detail.

**Commands to Display Help on the CLI Commands:**

<b>?</b>	<b>HELP</b>	<b>Comment</b>
<b>Description:</b>	Command help available for each of the options below.	
<b>Command combinations:</b>	?	Command line interpreter help menu.
	?]	Display help on access CE data RAM
	?)	Display help on access MPU RAM
	?,	Display help on repeat last command
	?/	Display help on ignore rest of line
	?C	Display help on compute engine control.
	?CL	Display help on calibration.
	?EE	Display help on EEPROM control
	?ER	Display help on error recording
	?I	Display help on information message
	?M	Display help on meter display control
	?MR	Display help on meter RMS display control
	?R	Display help on SFR control
	?RT	Display help on RTC control
	?T	Display help on trim control
	?W	Display help on the wait/reset command
	?Z	Display help on reset
<b>Examples:</b>	??	Display the command line interpreter help menu.
	?C	Displays compute engine control help.

**Commands for CE Data Access:**

<b>]</b>	<b>CE DATA ACCESS</b>	<b>Comment</b>
<b>Description:</b>	Allows user to read from and write to CE data space.	
<b>Usage:</b>	] [Starting CE Data Address] [option]...[option]	
<b>Command combinations:</b>	]A???	Read consecutive 16-bit words in Decimal, starting at address A
	]A\$\$\$	Read consecutive 16-bit words in Hex, starting at address A
	]A=n=n	Write consecutive memory values, starting at address A
	]U	Update default version of CE Data in flash memory
<b>Example:</b>	]40\$\$\$	Reads CE data words 0x40, 0x41 and 0x42.
	]7E=12345678=9876ABCD	Writes two words starting @ 0x7E

All CE data words are in 4-byte (32-bit) format. Typing ]A? will access the 32-bit word located at the byte address  $0x1000 + 4 * A = 0x1028$ .

**Commands for MPU/XDATA Access:**

)	MPU DATA ACCESS	Comment
<b>Description:</b>	Allows user to read from and write to MPU data space.	
<b>Usage:</b>	) [Starting MPU Data Address] [option]...[option]	
<b>Command combinations:</b>	)A???	Read three consecutive 32-bit words in Decimal, starting at address A
	)A\$\$\$	Read three consecutive 32-bit words in Hex, starting at address A
	)A=n=m	Write the values n and m to two consecutive addresses starting at address A
	?)	Display useful RAM addresses.
<b>Example:</b>	)08\$\$\$\$	Reads data words 0x08, 0x0C, 0x10, 0x14
	)04=12345678=9876ABCD	Writes two words starting @ 0x04

MPU or XDATA space is the address range for the MPU XRAM (0x0000 to 0xFFFF). All MPU data words are in 4-byte (32-bit) format. Typing )A? will access the 32-bit word located at the byte address  $4 * A = 0x28$ . The energy accumulation registers of the Demo Code can be accessed by typing two Dollar signs (“\$\$”), typing question marks will display negative decimal values if the most significant bit is set.

**Commands for DIO RAM (Configuration RAM) and SFR Control:**

R	DIO AND SFR CONTROL	Comment
<b>Description:</b>	Allows the user to read from and write to DIO RAM and special function registers (SFRs).	
<b>Usage:</b>	R [option] [register] ... [option]	
<b>Command combinations:</b>	Rix...	Select I/O RAM location x (0x2000 offset is automatically added)
	Rx...	Select internal SFR at address x
	Ra???	Read consecutive SFR registers in Decimal, starting at address a
	Ra\$\$\$...	Read consecutive registers in Hex, starting at address a
	Ra=n=m...	Set values of consecutive registers to n and m starting at address a
<b>Example:</b>	RI2\$\$\$	Read DIO RAM registers 2, 3, and 4 in Hex.

DIO or Configuration RAM space is the address range 0x2000 to 0x20FF. This RAM contains registers used for configuring basic hardware and functional properties of the 71M6533 and is organized in bytes (8 bits). The 0x2000 offset is automatically added when the command RI is typed.

The SFRs (special function registers) are located in internal RAM of the 80515 core, starting at address 0x80.

**Commands for EEPROM Control:**

EE	EEPROM CONTROL	Comment
<b>Description:</b>	Allows user to enable read and write to EEPROM.	
<b>Usage:</b>	EE [option] [arguments]	
<b>Command combinations:</b>	EECn	EEPROM Access (1 → Enable, 0 → Disable)
	EERa.b	Read EEPROM at address 'a' for 'b' bytes.
	EESabc...xyz	Write characters to buffer (sets Write length)
	EETa	Transmit buffer to EEPROM at address 'a'.
	EEWa.b...z	Write values to buffer
	CLS	Saves calibration to EEPROM
<b>Example:</b>	EEShello EET\$0210	Writes 'hello' to buffer, then transmits buffer to EEPROM starting at address 0x210.



Due to buffer size restrictions, the maximum number of bytes handled by the EEPROM command is 0x40.

**Auxiliary Commands:**

Typing a comma (",") repeats the command issued from the previous command line. This is very helpful when examining the value at a certain address over time, such as the CE DRAM address for the temperature (0x40).

The slash ("/") is useful to separate comments from commands when sending macro text files via the serial interface. All characters in a line after the slash are ignored.

**Commands controlling the CE, TMUX and the RTM:**

C	COMPUTE ENGINE CONTROL	Comment
<b>Description:</b>	Allows the user to enable and configure the compute engine.	
<b>Usage:</b>	C [option] [argument]	
<b>Command combinations:</b>	CEn	Compute Engine Enable (1 → Enable, 0 → Disable)
	CTn	Select input n for TMUX output pin. n is interpreted as a decimal number.
	CREn	RTM output control (1 → Enable, 0 → Disable)
	CRSa.b.c.d	Selects CE addresses for RTM output
<b>Example:</b>	CE0	Disables CE, followed by "CE OFF" display on LCD. The Demo Code will reset if the WD timer is enabled.
	CT3	Selects the VBIAS signal for the TMUX output pin

**Commands controlling the Auto-Calibration Function:**

CL	AUTO-CALIBRATION CONTROL	Comment
<b>Description:</b>	Allows the user to initiate auto-calibration and to store calibration values.	
<b>Usage:</b>	CL [option]	
<b>Command combinations:</b>	CLB	Begin auto-calibration. Prior to auto-calibration, the calibration coefficients are automatically restored from flash memory.
	CLS	Save calibration coefficients to EEPROM starting at address 0x0004
	CLC	Use machine-readable calibration protocol
	CLR	Restore calibration coefficients from EEPROM
	CLD	Restore coefficients from flash memory
<b>Example:</b>	CLB	Starts auto-calibration and saves data automatically.



Before starting the auto-calibration process, target values for voltage, duration and current must be entered in MPU RAM (see section 1.9.5) and the target voltage and current must be applied constantly during calibration. Calibration factors can be saved to EEPROM using the CLS command.

**Commands controlling the Pulse Counter Function**

CP	PULSE-COUNT CONTROL	Comment
<b>Description:</b>	Allows the user to control the pulse count functions.	
<b>Usage:</b>	CP [option]	
<b>Command combinations:</b>	CPA	Start pulse counting for time period defined with the CPD command. Pulse counts will display with commands M15.2, M16.2
	CPC	Clear the absolute pulse count displays (shown with commands M15.1, M16.1)
	CPDn	Set time window for pulse counters to n seconds, n is interpreted as a decimal number.
<b>Example:</b>	CPD60	Set time window to 60 seconds.



Pulse counts accumulated over a time window defined by the CPD command will be displayed by M14 after the defined time has expired.



M14 will display the absolute pulse count for the W and VAR outputs. These displays are reset to zero with the CPC command (or the XRAM write )1=2).

**Commands for Identification and Information:**

I	INFORMATION MESSAGES	Comment
<b>Description:</b>	Allows user to read information messages.	
<b>Usage:</b>	I	Displays complete version information

The I command is mainly used to identify the revisions of Demo Code and the contained CE code.

**Commands for Controlling the RMS Values Shown on the LCD Display:**

MR	METER RMS DISPLAY CONTROL (LCD)	Comment
<b>Description:</b>	Allows user to select meter RMS display for voltage or current.	
<b>Usage:</b>	MR [option]. [option]	
<b>Command combinations:</b>	MR1. [phase]	Displays instantaneous RMS current
	MR2. [phase]	Displays instantaneous RMS voltage
<b>Example:</b>	MR1.3	Displays phase C RMS current.



Phase 4 is the measured neutral current.

No error message is issued when an invalid parameter is entered, e.g. MR1.8.

**Commands for Controlling the MPU Power Save Mode:**

PS	POWER SAVE MODE	Comment
<b>Description:</b>	Enters power save mode	Disables CE, ADC, CKOUT, ECK, RTM, SSI, TMUX VREF, and serial port, sets MPU clock to 38.4KHz.
<b>Usage:</b>	PS	

Return to normal mode is achieved by resetting the MPU (Z command).

**Commands for Controlling the RTC:**

RT	REAL TIME CLOCK CONTROL	Comment
<b>Description:</b>	Allows the user to read and set the real time clock.	
<b>Usage:</b>	RT [option] [value] ... [value]	
<b>Command combinations:</b>	RTDy.m.d.w: Day of week	(year, month, day, weekday [1 = Sunday]). If the weekday is omitted it is set automatically.
	RTR	Read Real Time Clock.
	RTTh.m.s	Time of day: (hr, min, sec).
	RTAs.t	Real Time Adjust: (start, trim). Allows trimming of the RTC. If s > 0, the speed of the clock will be adjusted by 't' parts per billion (PPB). If the CE is on, the value entered with 't' will be changing with temperature, based on Y_CAL, Y_CALC and Y_CALC2.
<b>Example:</b>	RTD05.03.17.5	Programs the RTC to Thursday, 3/17/2005
	RTA1.+1234	Speeds up the RTC by 1234 PPB.



The "Military Time Format" is used for the RTC, i.e. 15:00 is 3:00 PM.

**Commands for Accessing the Trim Control Registers:**

T	TRIM CONTROL	Comment
<b>Description:</b>	Allows user to read trim and fuse values.	
<b>Usage:</b>	T [option]	
<b>Command combinations:</b>	T4	Read fuse 4 (TRIMM).
	T5	Read fuse 5 (TRIMBGA)
	T6	Read fuse 6 (TRIMBGB).
<b>Example:</b>	T4	Reads the TRIMM fuse.



These commands are only accessible for the 71M6533H (0.1%) parts. When used on a 71M6533 (0.5%) part, the results will be displayed as zero.

**Reset Commands:**

W	RESET	Comment
<b>Description:</b>	Watchdog control	
<b>Usage:</b>	W	Halts the Demo Code program, thus suppressing the triggering of the hardware watchdog timer. This will cause a reset, if the watchdog timer is enabled.

**Battery-Mode Commands:**

W	RESET	Comment
<b>Description:</b>	Control of Sleep and LCD Modes when in Brownout Mode	
<b>Commands:</b>	BL	Takes the 71M6533 to LCD Mode.
	BS	Takes the 71M6533 to Sleep Mode.
	BWSn	Takes the 71M6533 to Sleep Mode and sets the wake-up timer to n seconds.
	BWMn	Takes the 71M6533 to Sleep Mode and sets the wake-up timer to n minutes.

**Commands for Controlling the Metering Values Shown on the LCD Display:**

<b>M</b>	<b>METER DISPLAY CONTROL (LCD)</b>	<b>Comment</b>
<b>Description:</b>	Allows user to select internal variables to be displayed.	
<b>Usage:</b>	M [option]. [option]	
<b>Command combinations:</b>	M	Wh Total Consumption (display wraps around at 999.999)
	M0	Wh Total Consumption (display wraps around at 999.999)
	M1	Temperature (C° delta from nominal)
	M2	Frequency (Hz)
	M3. [phase]	Wh Total Consumption (display wraps around at 999.999)
	M4. [phase]	Wh Total Inverse Consumption (display wraps around at 999.999)
	M5. [phase]	VARh Total Consumption (display wraps around at 999.999)
	M6. [phase]	VARh Total Inverse Consumption (display wraps around at 999.999)
	M7. [phase]	VAh Total (display wraps around at 999.999)
	M8	Operating Time (in hours)
	M9	Real Time Clock
	M10	Calendar Date
	M11. [phase]	Power factor
	M13	Mains edge count for the last accumulation interval
	M13.1	Main edge count (accumulated) – zero transitions of the input signal
	M13.2	Main edge count for the last accumulation interval
	M14.1	Absolute count for Wh pulses. Reset with CPC command.
	M14.2	Absolute count for VARh pulses. Reset with CPC command.
	M15.[phase]	I RMS display
	M16.[phase]	V RMS display
<b>Example:</b>	M3.3	Displays Wh total consumption of phase C.
	M5.0	Displays VARh total consumption for all phases.



Displays for total consumption wrap around at 999.999Wh (or VARh, VAh) due to the limited number of available display digits. Internal registers (counters) of the Demo Code are 64 bits wide and do not wrap around.



When entering the phase parameter, use 1 for phase A, 2 for phase B, 3 for phase C, and 0 or blank for all phases.

## 1.8.2 USING THE DEMO BOARD FOR ENERGY MEASUREMENTS

The 71M6533-DB Demo Board was designed for use with current transformers (CT).

The Demo Board may immediately be used with current transformers having 2,000:1 winding ratio and is programmed for a Kh factor of 3.2 and (see Section 1.8.4 for adjusting the Demo Board for transformers with different turns ratio).

Once, voltage is applied and load current is flowing, the red LED D5 will flash each time an energy sum of 3.2 Wh is collected. The LCD display will show the accumulated energy in Wh when set to display mode 3 (command `>M3` via the serial interface).

Similarly, the red LED D6 will flash each time an energy sum of 3.2 VARh is collected. The LCD display will show the accumulated energy in VARh when set to display mode 5 (command `>M5` via the serial interface).

## 1.8.3 ADJUSTING THE KH FACTOR FOR THE DEMO BOARD

The 71M6533-DB Demo Board is shipped with a pre-programmed scaling factor Kh of 3.2, i.e. 3.2Wh per pulse. In order to be used with a calibrated load or a meter calibration system, the board should be connected to the AC power source using the spade terminals on the bottom of the board. The current transformers should be connected to the dual-pin headers on the bottom of the board.

The Kh value can be derived by reading the values for IMAX and VMAX (i.e. the RMS current and voltage values that correspond to the 250mV maximum input signal to the IC), and inserting them in the following equation for Kh:

$$Kh = IMAX * VMAX * 66.1782 / (In\_8 * WRATE * N_{ACC} * X) = 3.19902 \text{ Wh/pulse.}$$

The small deviation between the adjusted Kh of 3.19902 and the ideal Kh of 3.2 is covered by calibration. The default values used for the 71M6533-DB Demo Board are:

<i>WRATE</i> :	683	
<i>IMAX</i> :	208	
<i>VMAX</i> :	600	
<i>In_8</i> :	1	(controlled by <i>IA_SHUNT</i> = 0)
<i>N<sub>ACC</sub></i> :	2520	
<i>X</i> :	6	

### Explanation of factors used in the Kh calculation:

<i>WRATE</i> :	The factor input by the user to determine Kh
<i>IMAX</i> :	The current input scaling factor, i.e. the input current generating 177mVrms at the IA/IB/IC input pins of the 71M6533. 177mV rms is equivalent to 250mV peak.
<i>VMAX</i> :	The voltage input scaling factor, i.e. the voltage generating 177mVrms at the VA/VB/VC input pins of the 71M6533
<i>In_8</i> :	The setting for the additional ADC gain (8 or 1) determined by the CE register <i>IA_SHUNT</i>
<i>N<sub>ACC</sub></i> :	The number of samples per accumulation interval, i.e. <i>PRE_SAMPS * SUM_CYCLES</i>
<i>X</i> :	The pulse rate control factor determined by the CE registers <i>PULSE_SLOW</i> and <i>PULSE_FAST</i>

Almost any desired Kh factor can be selected for the Demo Board by resolving the formula for *WRATE*:

$$WRATE = (IMAX * VMAX * 66.1782) / (Kh * In\_8 * N_{ACC} * X)$$

For the Kh of 3.2Wh, the value 171 (decimal) should be entered for *WRATE* at location 21 (using the CLI command `>]21=+171`).

## 1.8.4 ADJUSTING THE DEMO BOARDS TO DIFFERENT CURRENT TRANSFORMERS

The Demo Board is prepared for use with 2000:1 current transformers (CTs). This means that for the unmodified Demo Board, 208A on the primary side at 2000:1 ratio result in 104mA on the secondary side, causing 177mV at the 1.7Ω resistor pairs R24/R25, R36/R37, R56/R57 (2 x 3.4Ω in parallel).

In general, when  $I_{MAX}$  is applied to the primary side of the CT, the voltage  $V_{in}$  at the IA, IB, or IC input of the 71M6533 IC is determined by the following formula:

$$V_{in} = R * I = R * I_{MAX}/N$$

where  $N$  = transformer winding ratio,  $R$  = resistor on the secondary side

If, for example,  $I_{MAX} = 208A$  are applied to a CT with a 2500:1 ratio, only 83.2mA will be generated on the secondary side, causing only 141mV. The steps required to adapt a 71M6533-DB Demo Board to a transformer with a winding ratio of 2500:1 are outlined below:

- 1) The formula  $R_x = 177mV/(I_{MAX}/N)$  is applied to calculate the new resistor  $R_x$ . We calculate  $R_x$  to 2.115 $\Omega$
- 2) **Changing the resistors R24/R25, R106/R107 to a combined resistance of 2.115 $\Omega$**  (for each pair) will cause the desired voltage drop of 177mV appearing at the IA, IB, or IC inputs of the 71M6533 IC.
- 3) *WRATE* should be adjusted to achieve the desired  $K_h$  factor, as described in 1.8.3.

Simply scaling  $I_{MAX}$  is not recommended, since peak voltages at the 71M6533 inputs should always be in the range of 0 through  $\pm 250mV$  (equivalent to 177mV rms). If a CT with a much lower winding ratio than 1:2,000 is used, higher secondary currents will result, causing excessive voltages at the 71M6533 inputs. Conversely, CTs with much higher ratio will tend to decrease the useable signal voltage range at the 71M6533 inputs and may thus decrease resolution.

## 1.8.5 ADJUSTING THE DEMO BOARDS TO DIFFERENT VOLTAGE DIVIDERS

The 71M6533-DB Demo Board comes equipped with its own network of resistor dividers for voltage measurement mounted on the PCB. The resistor values (for the 71M6533-DB Demo Board) are 2.5477M $\Omega$  (R15-R21, R26-R31 combined) and 750 $\Omega$  (R32), resulting in a ratio of 1:3,393.933. This means that  $V_{MAX}$  equals  $176.78mV * 3,393.933 = 600V$ . A large value for  $V_{MAX}$  has been selected in order to have headroom for over-voltages. This choice need not be of concern, since the ADC in the 71M6533 has enough resolution, even when operating at 120Vrms or 240Vrms.

If a **different set of voltage dividers** or an external voltage transformer (potential transformer) is to be used, scaling techniques similar to those applied for the current transformer should be used.

In the following example we assume that the line voltage is not applied to the resistor divider for VA formed by R15-R21, R26-R31, and R32, but to a voltage transformer with a ratio  $N$  of 20:1, followed by a simple resistor divider. We also assume that we want to maintain the value for  $V_{MAX}$  at 600V to provide headroom for large voltage excursions.

When applying  $V_{MAX}$  at the primary side of the transformer, the secondary voltage  $V_s$  is:

$$V_s = V_{MAX} / N$$

$V_s$  is scaled by the resistor divider ratio  $R_R$ . When the input voltage to the voltage channel of the 71M6533 is the desired 177mV,  $V_s$  is then given by:

$$V_s = R_R * 177mV$$

Resolving for  $R_R$ , we get:

$$R_R = (V_{MAX} / N) / 177mV = (600V / 30) / 177mV = 170.45$$

This divider ratio can be implemented, for example, with a combination of one 16.95k $\Omega$  and one 100 $\Omega$  resistor.

If potential transformers (PTs) are used instead of resistor dividers, phase shifts will be introduced that will require negative phase angle compensation. Standard Demo Code accepts negative calibration factors for phase.

## 1.9 CALIBRATION PARAMETERS

### 1.9.1 GENERAL CALIBRATION PROCEDURE

Any calibration method can be used with the 71M6533 chips. This Demo Board User's Manual presents calibration methods with three or five measurements as recommended methods, because they work with most manual calibration systems based on counting "pulses" (emitted by LEDs on the meter).

Naturally, a meter in mass production will be equipped with special calibration code offering capabilities beyond those of the Demo Code. It is basically possible to calibrate using voltage and current readings, with or without pulses involved. For this purpose, the MPU Demo Code can be modified to display averaged voltage and current values (as opposed to momentary values). Also, automated calibration equipment can communicate with the Demo Boards via the serial interface and extract voltage and current readings. This is possible even with the unmodified Demo Code.

Complete calibration procedures are given in section 2.2 of this manual.

Regardless of the calibration procedure used, parameters (calibration factors) will result that will have to be applied to the 71M6533 chip in order to make the chip apply the modified gains and phase shifts necessary for accurate operation. Table 1-2 shows the names of the calibration factors, their function, and their location in the CE RAM.

Again, the command line interface can be used to store the calibration factors in their respective CE RAM addresses. For example, the command

```
>]10=+16302
```

stores the decimal value 16302 in the CE RAM location controlling the gain of the current channel (*CAL\_IA*) for phase A.

The command

```
>]11=4005
```

stores the hexadecimal value 0x4005 (decimal 16389) in the CE RAM location controlling the gain of the voltage channel for phase A (*CAL\_VA*).

Constant	CE Address (hex)	Description
<i>CAL_VA</i> <i>CAL_VB</i> <i>CAL_VC</i>	0x11 0x13 0x15	Adjusts the gain of the voltage channels. +16384 is the typical value. The gain is directly proportional to the CAL parameter. Allowed range is 0 to 32767. If the gain is 1% slow, CAL should be increased by 1%.
<i>CAL_IA</i> <i>CAL_IB</i> <i>CAL_IC</i>	0x10 0x12 0x14	Adjusts the gain of the current channels. +16384 is the typical value. The gain is directly proportional to the CAL parameter. Allowed range is 0 to 32767. If the gain is 1% slow, CAL should be increased by 1%.
<i>PHADJ_A</i> <i>PHADJ_B</i> <i>PHADJ_C</i>	0x18 0x19 0x1A	This constant controls the CT phase compensation. No compensation occurs when PHADJ=0. As PHADJ is increased, more compensation is introduced.

Table 1-2: CE RAM Locations for Calibration Constants

## 1.9.2 CALIBRATION MACRO FILE

The macro file in Figure 1-6 contains a sequence of the serial interface commands. It is a simple text file and can be created with Notepad or an equivalent ASCII editor program. The file is executed with HyperTerminal's *Transfer->Send Text File* command.

```

CE0          /disable CE
]10=+16022   /CAL_IA (gain=CAL_IA/16384)
]11=+16381   /CAL_VA (gain=CAL_VA/16384)
]12=+16019   /CAL_IB (gain=CAL_IB/16384)
]13=+16370   /CAL_VB (gain=CAL_VB/16384)
]14=+15994   /CAL_IC (gain=CAL_IC/16384)
]15=+16376   /CAL_VC (gain=CAL_VC/16384)
]18=+115     /PHADJ_A (default 0)
]19=+113     /PHADJ_B (default 0)
]1A=+109     /PHADJ_C (default 0)
CE1          /enable CE

```

Figure 1-6: Typical Calibration Macro File

It is possible to send the calibration macro file to the 71M6533H for “temporary” calibration. This will temporarily change the CE data values. Upon power up, these values are refreshed back to the default values stored in flash memory. Thus, until the flash memory is updated, the macro file must be loaded each time the part is powered up.

The macro file is run by sending it with the *transfer → send text file* procedure of HyperTerminal.



**Use the *Transfer → Send Text File* command!**

## 1.9.3 UPDATING THE DEMO CODE (HEX FILE)

The *d\_merge* program updates the hex file (usually named *6533\_4p6b\_19jan08.hex* or similar) with the values contained in the macro file. This program is executed from a DOS command line window. Executing the *d\_merge* program with no arguments will display the syntax description. To merge *macro.txt* and *old\_6533\_demo.hex* into *new\_6533\_demo.hex*, use the command:

```
d_merge old_6533_demo.hex macro.txt new_6533_demo.hex
```

The new hex file can be written to the 71M6533 through the ICE port using the ADM51 in-circuit emulator or the TFP2 flash programmer.

## 1.9.4 UPDATING CALIBRATION DATA IN FLASH OR EEPROM

It is possible to make data permanent that had been entered temporarily into the CE RAM. The transfer to flash memory is done using the following serial interface command:

```
>]U
```

Thus, after transferring calibration data with manual serial interface commands or with a macro file, all that has to be done is invoking the U command.

Similarly, calibration data can also be stored in EEPROM using the CLS command.



**After reset, calibration data is copied from the EEPROM, if present. Otherwise, calibration data is copied from the flash memory. Writing 0xFF into the first few bytes of the EEPROM deactivates any calibration data previously stored to the EEPROM.**

## 1.9.5 AUTOMATIC GAINS CALIBRATION

The Demo Code is able to perform a single-point fast automatic calibration, as described in section 2.2. This calibration is performed for channels A, B, and C only, not for the NEUTRAL channel. The steps required for the calibration are:

1. Enter operating values for voltage and current in I/O RAM. The voltage is entered at MPU address 0x10 (e.g. with the command )10=+2400 for 240V), the current is entered at 0x11 (e.g. with the command )11=+300 for 30A) and the duration measured in accumulation intervals is entered at 0x0F.
2. The operating voltage and current defined in step 1 must be applied at a zero degree phase angle to the meter (Demo Board).
3. The CLB (Begin Calibration) command must be entered via the serial interface. The operating voltage and current must be maintained accurately while the calibration is being performed.
4. The calibration procedure will automatically reset CE addresses used to store the calibration factors to their default values prior to starting the calibration. Automatic calibration also reads the chip temperature and enters it at the proper CE location temperature compensation.
5. CE addresses 0x10 to 0x15 and 0x18 to 0x1A will now show the new values determined by the auto-calibration procedure. These values can be stored in EEPROM by issuing the CLS command.



Tip: Current transformers of a given type usually have very similar phase angle for identical operating conditions. If the phase angle is accurately determined for one current transformer, the corresponding phase adjustment coefficient *PHADJ\_X* can be entered for all calibrated units.

## 1.9.6 LOADING THE CODE FOR THE 6533 INTO THE DEMO BOARD

**Hardware Interface for Programming:** The 71M6533 IC provides an interface for loading code into the internal flash memory. This interface consists of the following signals:

E\_RXTX (data), E\_TCLK (clock), E\_RST (reset), ICE\_E (ICE enable)

These signals, along with V3P3D and GND are available on the emulator headers J14 and J17. Production meters may be equipped with simple programming connectors, such as the 6x1 header used for J17.

Programming of the flash memory requires a specific in-circuit emulator, the ADM51 by Signum Systems (<http://www.signumsystems.com>) or the Flash Programmer (TFP2) available through Maxim distributors.

Chips may also be programmed before they are soldered to the board.

**In-Circuit Emulator:** If firmware exists in the 71M6533 flash memory; it has to be erased before loading a new file into memory. Figure 1-7 and Figure 1-8 show the emulator software active. In order to erase the flash memory, the RESET button of the emulator software has to be clicked followed by the ERASE button ().

Once the flash memory is erased, the new file can be loaded using the commands File followed by Load. The dialog box shown in Figure 1-8 will then appear making it possible to select the file to be loaded by clicking the Browse button. Once the file is selected, pressing the OK button will load the file into the flash memory of the 71M6533 IC.

At this point, the emulator probe (cable) can be removed. Once the 71M6533 IC is reset using the reset button on the Demo Board, the new code starts executing.

**Flash Programmer Module (TFP2):** Follow the instructions given in the User Manual for the TFP2.

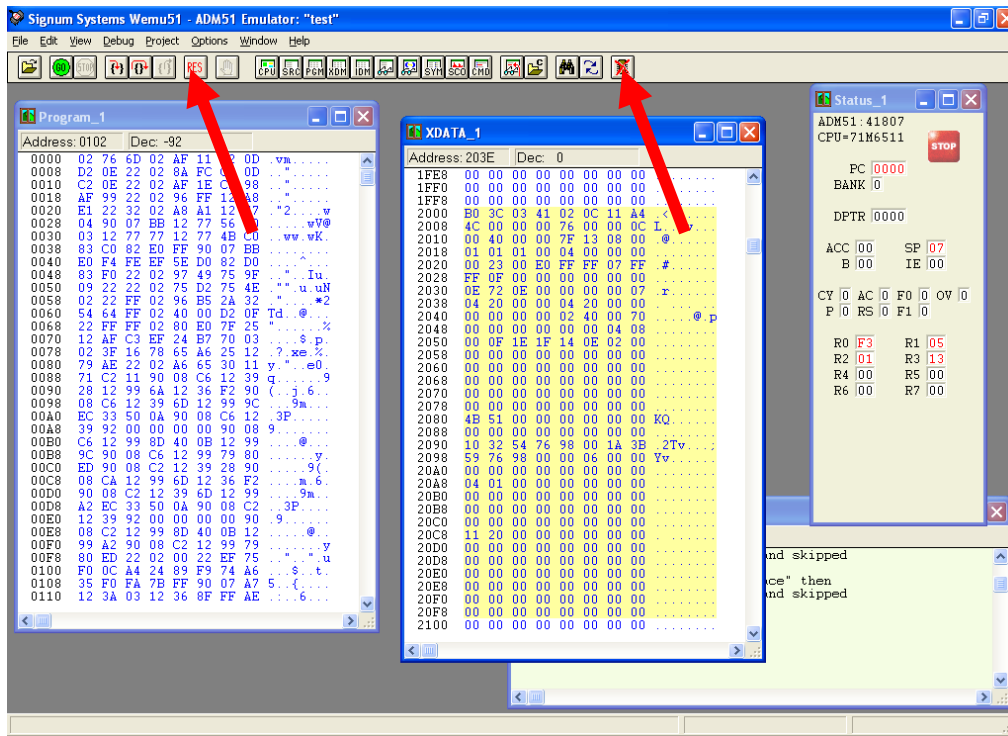

Figure 1-7: Emulator Window Showing Reset and Erase Buttons (see Arrows)

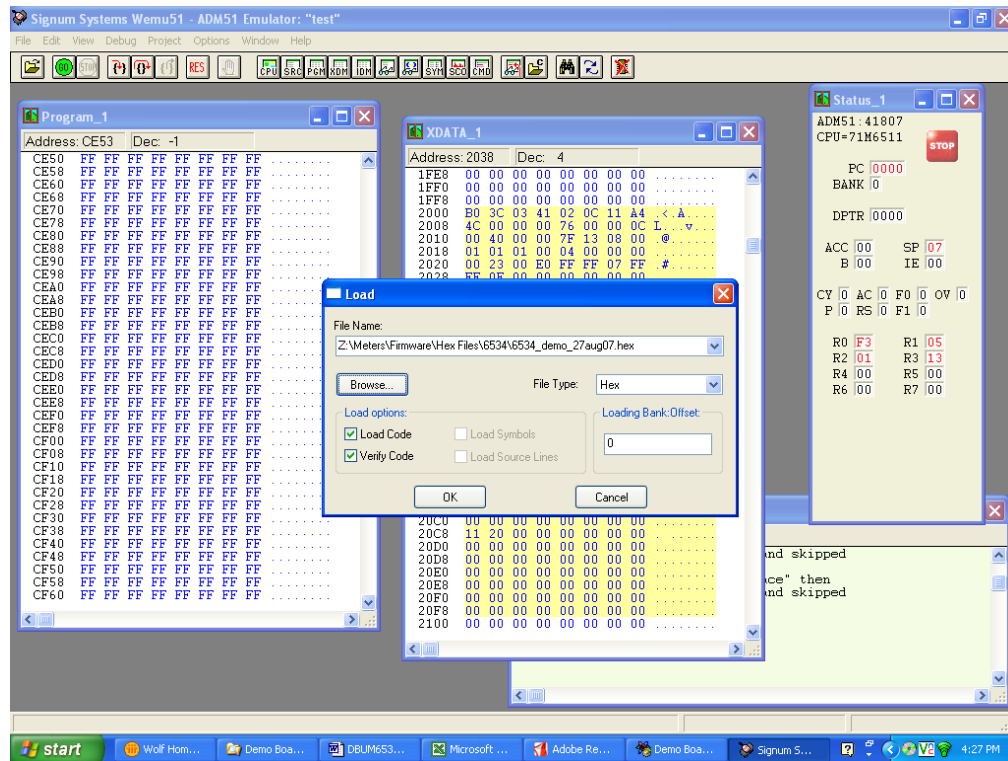

Figure 1-8: Emulator Window Showing Erased Flash Memory and File Load Menu

## 1.9.7 THE PROGRAMMING INTERFACE OF THE 71M6533

### Flash Downloader/ICE Interface Signals

The signals listed in Table 1-3 are necessary for communication between the Flash Downloader or ICE and the 71M6533.

Signal	Direction	Function
ICE_E	Input to the 71M6533	ICE interface is enabled when ICE_E is pulled high
E_TCLK	Output from 71M6533	Data clock
E_RXTX	Bi-directional	Data input/output
E_RST	Bi-directional	Flash Downloader Reset (active low)

**Table 1-3: Flash Programming Interface Signals**



The E\_RST signal should only be driven by the Flash Downloader when enabling these interface signals. The Flash Downloader must release E\_RST at all other times.

## 1.10 DEMO CODE

### 1.10.1 DEMO CODE DESCRIPTION

The Demo Board is shipped preloaded with Demo Code revision 4.4.16 or later in the 71M6533 or 71M6533H chip. The code revision can easily be verified by entering the command `>i` via the serial interface (see section 1.8.1). Check with your local MAXIM INTEGRATED PRODUCTS representative or FAE for the latest revision.

The Demo Code offers the following features:

- It provides basic metering functions such as pulse generation, display of accumulated energy, frequency, date/time, and enables the user to evaluate the parameters of the metering IC such as accuracy, harmonic performance, etc.
- It maintains and provides access to basic household functions such as real-time clock (RTC).
- It provides access to control and display functions via the serial interface, enabling the user to view and modify a variety of meter parameters such as Kh, calibration coefficients, temperature compensation etc.
- It provides libraries for access of low-level IC functions to serve as building blocks for code development.

A detailed description of the Demo Code can be found in the Software User's Guide (SUG). In addition, the comments contained in the library provided with the Demo Kit can serve as useful documentation.

The Software User's Guide contains the following information:

- Design guide
- Design reference for routines
- Tool Installation Guide
- List of library functions
- 80515 MPU Reference (hardware, instruction set, memory, registers)

### 1.10.2 IMPORTANT DEMO CODE MPU PARAMETERS

In the Demo Code, certain MPU **XRAM** parameters have been given fixed addresses in order to permit easy external access. These variables can be read via the serial interface, as described in section 1.7.1, with the `)n$` command and written with the `)n=xx` command where `n` is the word address. Note that accumulation variables

are 64 bits long and are accessed with  $\mu n\$$  (read) and  $\mu n=hh=ll$  (write) in the case of accumulation variables. Default values are the values assigned by the Demo Code on start-up.

All MPU Input Parameters are loaded by the MPU at startup and should not need adjustment during meter calibration.

#### MPU Input Parameters for Metering

XRAM Word Address	Default Value	Name	Description
0x00	433199	<i>ITHRSHLDA</i>	For each element, if <i>WSUM_X</i> or <i>VARSUM_X</i> of that element exceeds <i>WCREEP_THR</i> , the sample values for that element are not zeroed. Otherwise, the accumulators for Wh, VARh, and VAh are not updated and the instantaneous value of IRMS for that element is zeroed.  $LSB = \sqrt{IOSQSUM} \cdot 2^{16}$  The default value is equivalent to 0.08A. Setting <i>ITHRSHLDA</i> to zero disables creep control.
0x01	0	<i>CONFIG</i>	Bit 0: Sets VA calculation mode.  0: $V_{RMS} \cdot A_{RMS}$ 1: $\sqrt{W^2 + VAR^2}$  Bit 1: Clears accumulators for Wh, VARh, and VAh. This bit need not be reset.
0x02	764569660	<i>PK_VTHR</i>	When the voltage exceeds this value, bit 5 in the MPU status word is set, and the MPU might choose to log a warning. Event logs are not implemented in Demo Code.  $LSB = \sqrt{VOSQSUM} \cdot 2^{16}$  The default value is equivalent to 20% above 240Vrms.
0x03	275652520	<i>PK_ITHR</i>	When the current exceeds this value, bit 6 in the MPU status word is set, and the MPU might choose to log a warning. Event logs are not implemented in Demo Code.  $LSB = \sqrt{IOSQSUM} \cdot 2^{16}$  The default value is equivalent to 20% above $30A_{RMS}$ .
0x04	0	<i>Y_CAL_DEG0</i>	RTC adjust, 100ppb. Read only at reset in demo code.
0x05	0	<i>Y_CAL_DEG1</i>	RTC adjust, linear by temperature, 10ppb* $\Delta T$ , in 0.1°C. Provided for optional code.
0x06	0	<i>Y_CAL_DEG2</i>	RTC adjust, squared by temperature, 1ppb* $\Delta T^2$ , in 0.1°C. Provided for optional code.
0x07	0	<i>PULSEW_SRC</i>	This address contains a number that points to the selected pulse source for the Wh output. Selectable pulse sources are listed in Table 1-5.
0x08	4	<i>PULSER_SRC</i>	This address contains a number that points to the selected pulse source for the VARh output. Selectable pulse sources are listed in Table 1-5.
0x09	6000	<i>VMAX</i>	The nominal external RMS voltage that corresponds to 250mV peak at the ADC input. The meter uses this value to convert internal quantities to external. LSB=0.1V
0x0A	2080	<i>IMAX</i>	The nominal external RMS current that corresponds to 250mV peak at the ADC input for channel A. The meter uses this value to convert internal quantities to external. LSB=0.1A

XRAM Word Address	Default Value	Name	Description
0x0B	0	<i>PPMC</i>	PPM/C*26.84. Linear temperature compensation. A positive value will cause the meter to run faster when hot. This is applied to both V and I and will therefore have a double effect on products.
0x0C	0	<i>PPMC2</i>	PPM/C <sup>2</sup> *1374. Square law compensation. A positive value will cause the meter to run faster when hot. This is applied to both V and I and will therefore have a double effect on products.
0x0D		<i>PULSEX_SRC</i>	This address contains a number that points to the selected pulse source for the XPULSE output. Selectable pulse sources are listed in Table 1-5.
0x0E		<i>PULSEY_SRC</i>	This address contains a number that points to the selected pulse source for the YPULSE output. Selectable pulse sources are listed in Table 1-5.
0x0F	2	<i>SCAL</i>	Count of accumulation intervals for auto-calibration.
0x10	2400	<i>VCAL</i>	Applied voltage for auto-calibration. LSB = 0.1V rms of AC signal applied to all elements during calibration.
0x11	300	<i>ICAL</i>	Applied current for auto-calibration. LSB = 0.1A rms of AC signal applied to all elements during calibration. Power factor must be 1.
0x12	75087832	<i>VTHRSHLD</i>	Voltage to be used for creep detection, measuring frequency, zero crossing, etc.
0x13	50	<i>PULSE_WIDTH</i>	Pulse width in $\mu\text{s} = (2 * \text{PulseWidth} + 1) * 397$ . 0xFF disables this feature. Takes effect only at start-up.
0x14	--	<i>TEMP_NOM</i>	Nominal (reference) temperature, i.e. the temperature at which calibration occurred. LSB = Units of <i>TEMP_RAW</i> , from CE.
0x15	--	<i>NCOUNT</i>	The count of accumulation intervals that the neutral current must be above <i>INTHRSHLD</i> required to set the "excess neutral" error bit.
0x16	--	<i>INTHRSHLD</i>	The neutral current threshold. $LSB = \sqrt{I_x \text{SQSUM}} \cdot 2^{16}$

Table 1-4: MPU Input Parameters for Metering

Any of the values listed in Table 1-5 can be selected for as a source for PULSEW and PULSER. The designation "source\_I" refers to values imported by the consumer; "source\_E" refers to energy exported by the consumer (energy generation).

Number	Pulse Source	Description
0	<i>WSUM</i>	<b>Default for <i>PULSEW_SRC</i></b>
1	<i>WOSUM</i>	
2	<i>WISUM</i>	
3	<i>W2SUM</i>	
4	<i>VARSUM</i>	<b>Default for <i>PULSER_SRC</i></b>
5	<i>VAROSUM</i>	
6	<i>VARISUM</i>	
7	<i>VAR2SUM</i>	

Number	Pulse Source	Description
18	<i>VA2SUM</i>	
19	<i>WSUM_I</i>	Sum of imported real energy
20	<i>WOSUM_I</i>	Imported real energy on element A
21	<i>WISUM_I</i>	Imported real energy on element B
22	<i>W2SUM_I</i>	Imported real energy on element C
23	<i>VARSUM_I</i>	Sum of imported reactive energy
24	<i>VAROSUM_I</i>	Imported reactive energy on element A
25	<i>VARISUM_I</i>	Imported reactive energy on element B

Number	Pulse Source	Description	Number	Pulse Source	Description
8	<i>I0SQSUM</i>		26	<i>VARISUM_I</i>	Imported reactive energy on element C
9	<i>I1SQSUM</i>		27	<i>WSUM_E</i>	Sum of exported real energy
10	<i>I2SQSUM</i>		28	<i>W0SUM_E</i>	Exported real energy on element A
11	<i>INSQSUM</i>		29	<i>W1SUM_E</i>	Exported real energy on element B
12	<i>V0SQSUM</i>		30	<i>W2SUM_E</i>	Exported real energy on element C
13	<i>V1SQSUM</i>		31	<i>VARSUM_E</i>	Sum of exported reactive energy
14	<i>V2SQSUM</i>		32	<i>VAR0SUM_E</i>	Exported reactive energy on element A
15	<i>VASUM</i>		33	<i>VARISUM_E</i>	Exported reactive energy on element B
16	<i>VA0SUM</i>		34	<i>VAR2SUM_E</i>	Exported reactive energy on element C
17	<i>VAISUM</i>				

Table 1-5: Selectable Pulse Sources

#### MPU INSTANTANEOUS OUTPUT VARIABLES

The Demo Code processes CE outputs after each accumulation interval. It calculates instantaneous values such as VRMS, IRMS, W and VA as well as accumulated values such as Wh, VARh, and VAh. Table 1-6 lists the calculated instantaneous values.

XRAM Word Address	Name	DESCRIPTION
0x24 0x26 0x28	Vrms_A Vrms_B* Vrms_C	V <sub>rms</sub> from element 0, 1, 2. $LSB = \sqrt{V_xSQSUM} \cdot 2^{16}$
0x25 0x27 0x29	Irms_A Irms_B Irms_C Irms_N	I <sub>rms</sub> from element 0, 1, 2 or neutral $LSB = \sqrt{I_xSQSUM} \cdot 2^{16}$
0x20	Delta_T	Deviation from Calibration (reference) temperature. LSB = 0.1 °C.
0x21	Frequency	Frequency of voltage selected by CE input. If the selected voltage is below the sag threshold, Frequency=0. LSB Hz

Table 1-6: MPU Instantaneous Output Variables

**MPU STATUS WORD**

The MPU maintains the status of certain meter and I/O related variables in the Status Word. The Status Word is located at address 0x21. The bit assignments are listed in Table 1-7.

Status Word Bit	Name	DESCRIPTION
0	<i>CREEP</i>	Indicates that all elements are in creep mode. The CE's pulse variables will be "jammed" with a constant value on every accumulation interval to prevent spurious pulses. Note that creep mode therefore halts pulsing even when the CE's pulse mode is "internal".
1	<i>MINVC</i>	Element C has a voltage below VThrshld. This forces that element into creep mode.
2	<i>PB_PRESS</i>	A push button press was recorded at the most recent reset or wake from a battery mode.
3	<i>SPURIOUS</i>	An unexpected interrupt was detected.
4	<i>MINVB</i>	Element B has a voltage below VThrshld. This forces that element into creep mode.
5	<i>MAXVA</i>	Element A has a voltage above VThrshldP.
6	<i>MAXVB</i>	Element B has a voltage above VThrshldP.
7	<i>MAXVC</i>	Element C has a voltage above VThrshldP.
8	<i>MINVA</i>	Element A has a voltage below VThrshld. This forces that element into creep mode. It also forces the frequency and main edge count to zero.
9	<i>WD_DETECT</i>	The most recent reset was a watchdog reset. This usually indicates a software error.
10	<i>MAXIN</i>	The neutral current is over INThrshld. In a real meter this could indicate faulty distribution or tampering.
11	<i>MAXIA</i>	The current of element A is over IThrshld. In a real meter this could indicate overload.
12	<i>MAXIB</i>	The current of element B is over IThrshld. In a real meter this could indicate overload.
13	<i>MAXIC</i>	The current of element C is over IThrshld. In a real meter this could indicate overload.
14	<i>MINT</i>	The temperature is below the minimum, -40C, established in option_gbl.h. This is not very accurate in the demo code, because the calibration temperature is usually poorly controlled, and the default temp_nom is usually many degrees off. -40C is the minimum recommended operating temperature of the chip.
15	<i>MAXT</i>	The temperature is above the maximum, 85C, established in option_gbl.h. This is not very accurate in the demo code, because the calibration temperature is usually poorly controlled, and the default temp_nom is usually many degrees off. 85C is the maximum recommended operating temperature of the chip.
16	<i>BATTERY_BAD</i>	Just after midnight, the demo code sets this bit if VBat < VBatMin. The read is infrequent to reduce battery loading to very low values. When the battery voltage is being displayed, the read occurs every second, for up to 20 seconds.
17	<i>CLOCK_TAMPER</i>	Clock set to a new value more than two hours from the previous value.
18	<i>CAL_BAD</i>	Set after reset when the read of the calibration data has a bad longitudinal redundancy check or read failure.
19	<i>CLOCK_UNSET</i>	Set when the clock's current reading is A) More than a year after the previously saved reading, or B) Earlier than the previously saved reading, or C) There is no previously saved reading.

Status Word Bit	Name	DESCRIPTION
20	<i>POWER_BAD</i>	Set after reset when the read of the power register data has a bad longitudinal redundancy check or read failure in both copies. Two copies are used because a power failure can occur while one of the copies is being updated.
21	<i>GNDNEUTRAL</i>	Indicates that a grounded neutral was detected.
22	<i>TAMPER</i>	Tamper was detected †**
23	<i>SOFTWARE</i>	A software defect was detected.
25	<i>SAGA</i>	Element A has a sag condition. This bit is set in real time by the CE and detected by the ce_busy interrupt (ce_busy_isr() in ce.c) within 8 sample intervals, about 2.6ms. A transition from normal operation to SAGA causes the power registers to be saved, because the demo PCB is powered from element A.
26	<i>SAGB</i>	Element B has a sag condition. This bit is set in real time by the CE and detected by the ce_busy interrupt (ce_busy_isr() in ce.c) within 8 sample intervals, about 2.6ms.
27	<i>SAGC†</i>	Element C has a sag condition. See the description of the other sag bits.
28	<i>F0_CE</i>	A square wave at the line frequency, with a jitter of up to 8 sample intervals, about 2.6ms.
31	<i>ONE_SEC</i>	Changes each accumulation interval.

Table 1-7: MPU Status Word Bit Assignment

#### MPU ACCUMULATION OUTPUT VARIABLES

Accumulation values are accumulated from XFER cycle to XFER cycle (see Table 1-8). They are organized as two 32-bit registers. The first register stores the decimal number displayed on the LCD. For example, if the LCD shows "001.004", the value in the first register is 1004. This register wraps around after the value 999999 is reached. The second register holds fractions of the accumulated energy, with an LSB of  $9.4045 \times 10^{-13} \times VMAX \times IMAX \times In_8 \text{ Wh}$ .

The MPU accumulation registers always hold positive values.

The CLI commands with two question marks, e.g. )39?? should be used to read the variables.

XRAM Word Address	Name	Description
0x2C	<i>Whi</i>	Total Watt hours consumed (imported)
0x44	<i>Whe</i>	Total Watt hours generated (exported)
0x34	<i>VARhi</i>	Total VAR hours consumed
0x4C	<i>VARhe</i>	Total VAR hours generated (inverse consumed)
0x3C	<i>VAh</i>	Total VA hours
0x2E	<i>Whi_A</i>	Total Watt hours consumed through element 0
0x46	<i>Whe_A</i>	Total Watt hours generated (inverse consumed) through element 0
0x36	<i>VARhi_A</i>	Total VAR hours consumed through element 0
0x4E	<i>VARhe_A</i>	Total VAR hours generated (inverse consumed) through element 0
0x3E	<i>VAh_A</i>	Total VA hours in element 0
0x30	<i>Whi_B</i>	Total Watt hours consumed through element 1
0x48	<i>Whe_B</i>	Total Watt hours generated (inverse consumed) through element 1
0x38	<i>VARhi_B</i>	Total VAR hours consumed through element 1
0x50	<i>VARhe_B</i>	Total VAR hours generated (inverse consumed) through element 1

0x40	<i>Vah_B</i>	Total VA hours in element 1
0x32	<i>Whi_C</i>	Total Watt hours consumed through element 2
0x4A	<i>Whe_C</i>	Total Watt hours generated (inverse consumed) through element 2
0x3A	<i>VARhi_C</i>	Total VAR hours consumed through element 2
0x52	<i>VARhe_C</i>	Total VAR hours generated (inverse consumed) through element 2
0x42	<i>VAh_C</i>	Total VA hours in element 2

**Table 1-8: MPU Accumulation Output Variables**

### 1.10.3 USEFUL CLI COMMANDS INVOLVING THE MPU AND CE

Table 1-9 shows a few essential commands involving data memory.

Command	Description
)1=2	Clears the accumulators for Wh, VARh, and VAh by setting bit 1 of the <i>CONFIG</i> register.
)A=+2080	Applies the value 208A to the IMAX register
)9=+6000	Applies the value 600V to the VMAX register
)2F??	Displays the total accumulated imported Wh energy
MR2.1	Displays the current RMS voltage in phase A
MR1.2	Displays the current RMS current in phase B
RI5=26	Disables the emulator clock by setting bit 5 in I/O RAM address 0x05. This command will disable emulator/programmer access to the 71M6533.
RI5=6	Re-enables the emulator clock by clearing bit 5 in I/O RAM address 0x05.
JU	Stores the current CE RAM variables to flash memory. The variables stored in flash memory will be applied by the MPU at the next reset or power-up if no valid data is available from the EEPROM.

**Table 1-9: CLI Commands for Data Memory**



## 2

## 2 APPLICATION INFORMATION

### 2.1 CALIBRATION THEORY

A typical meter has phase and gain errors as shown by  $\phi_S$ ,  $A_{XI}$ , and  $A_{XV}$  in Figure 2-1. Following the typical meter convention of current phase being in the lag direction, the small amount of phase lead in a typical current sensor is represented as  $-\phi_S$ . The errors shown in Figure 2-1 represent the sum of all gain and phase errors. They include errors in voltage attenuators, current sensors, and in ADC gains. In other words, no errors are made in the 'input' or 'meter' boxes.

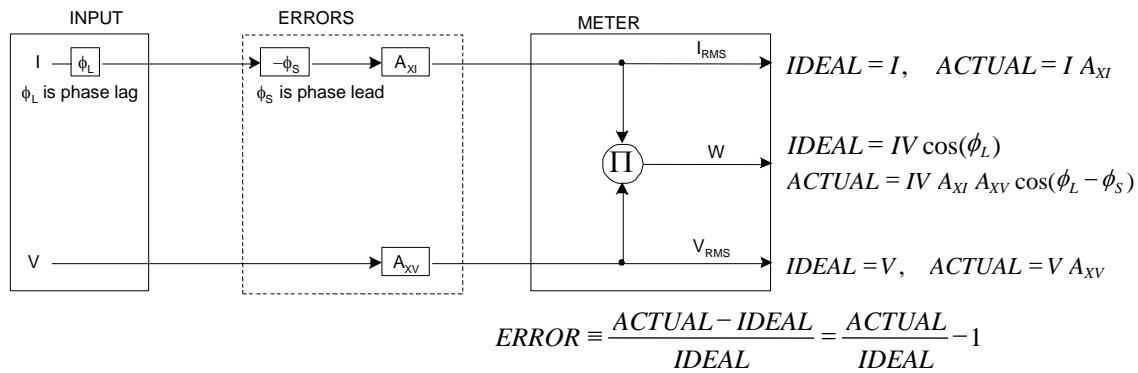

**Figure 2-1: Watt Meter with Gain and Phase Errors.**

During the calibration phase, we measure errors and then introduce correction factors to nullify their effect. With three unknowns to determine, we must make at least three measurements. If we make more measurements, we can average the results.

#### 2.1.1 CALIBRATION WITH THREE MEASUREMENTS

The simplest calibration method is to make three measurements. Typically, a voltage measurement and two Watt-hour (Wh) measurements are made. A voltage display can be obtained for test purposes via the command **>MR2.1** in the serial interface.

Let's say the voltage measurement has the error  $E_V$  and the two Wh measurements have errors  $E_0$  and  $E_{60}$ , where  $E_0$  is measured with  $\phi_L = 0$  and  $E_{60}$  is measured with  $\phi_L = 60$ . These values should be simple ratios—not percentage values. They should be zero when the meter is accurate and negative when the meter runs slow. The fundamental frequency is  $f_0$ .  $T$  is equal to  $1/f_S$ , where  $f_S$  is the sample frequency (2560.62Hz). Set all calibration factors to nominal:  $CAL\_IA = 16384$ ,  $CAL\_VA = 16384$ ,  $PHADJA = 0$ .

From the voltage measurement, we determine that

$$1. \rightarrow A_{XV} = E_V + 1$$

We use the other two measurements to determine  $\phi_S$  and  $A_{XI}$ .

$$2. E_0 = \frac{IV A_{XV} A_{XI} \cos(0 - \phi_S)}{IV \cos(0)} - 1 = A_{XV} A_{XI} \cos(\phi_S) - 1$$

$$2a. A_{XV} A_{XI} = \frac{E_0 + 1}{\cos(\phi_S)}$$

$$3. E_{60} = \frac{IV A_{XV} A_{XI} \cos(60 - \phi_S)}{IV \cos(60)} - 1 = A_{XV} A_{XI} \frac{\cos(60 - \phi_S)}{\cos(60)} - 1$$

$$3a. E_{60} = \frac{A_{XV} A_{XI} [\cos(60) \cos(\phi_S) + \sin(60) \sin(\phi_S)]}{\cos(60)} - 1$$

$$= A_{XV} A_{XI} \cos(\phi_S) + A_{XV} A_{XI} \tan(60) \sin(\phi_S) - 1$$

Combining 2a and 3a:

$$4. E_{60} = E_0 + (E_0 + 1) \tan(60) \tan(\phi_S)$$

$$5. \tan(\phi_S) = \frac{E_{60} - E_0}{(E_0 + 1) \tan(60)}$$

$$6. \rightarrow \phi_S = \tan^{-1} \left( \frac{E_{60} - E_0}{(E_0 + 1) \tan(60)} \right)$$

and from 2a:

$$7. \rightarrow A_{XI} = \frac{E_0 + 1}{A_{XV} \cos(\phi_S)}$$

Now that we know the  $A_{XV}$ ,  $A_{XI}$ , and  $\phi_S$  errors, we calculate the new calibration voltage gain coefficient from the previous ones:

$$CAL\_V_{NEW} = \frac{CAL\_V}{A_{XV}}$$

We calculate PHADJ from  $\phi_S$ , the desired phase lag:

$$PHADJ = 2^{20} \left[ \frac{\tan(\phi_S) [1 + (1 - 2^{-9})^2 - 2(1 - 2^{-9}) \cos(2\pi f_0 T)]}{(1 - 2^{-9}) \sin(2\pi f_0 T) - \tan(\phi_S) [1 - (1 - 2^{-9}) \cos(2\pi f_0 T)]} \right]$$

Finally, we calculate the new calibration current gain coefficient, including compensation for a slight gain increase in the phase calibration circuit.

$$CAL\_I_{NEW} = \frac{CAL\_I}{A_{XI}} \frac{1}{\sqrt{1 + \frac{2^{-20} PHADJ(2 + 2^{-20} PHADJ - 2(1 - 2^{-9}) \cos(2\pi f_0 T))}{1 - 2(1 - 2^{-9}) \cos(2\pi f_0 T) + (1 - 2^{-9})^2}}}$$

## 2.1.2 CALIBRATION WITH FIVE MEASUREMENTS

The five measurement method provides more orthogonality between the gain and phase error derivations. This method involves measuring  $E_V$ ,  $E_0$ ,  $E_{180}$ ,  $E_{60}$ , and  $E_{300}$ . Again, set all calibration factors to nominal, i.e.  $CAL\_IA = 16384$ ,  $CAL\_VA = 16384$ ,  $PHADJA = 0$ .

First, calculate  $A_{XV}$  from  $E_V$ :

$$1. \rightarrow A_{XV} = E_V + 1$$

Calculate  $A_{XI}$  from  $E_0$  and  $E_{180}$ :

$$2. E_0 = \frac{IV A_{XV} A_{XI} \cos(0 - \phi_S)}{IV \cos(0)} - 1 = A_{XV} A_{XI} \cos(\phi_S) - 1$$

$$3. E_{180} = \frac{IV A_{XV} A_{XI} \cos(180 - \phi_S)}{IV \cos(180)} - 1 = A_{XV} A_{XI} \cos(\phi_S) - 1$$

$$4. E_0 + E_{180} = 2A_{XV} A_{XI} \cos(\phi_S) - 2$$

$$5. A_{XV} A_{XI} = \frac{E_0 + E_{180} + 2}{2 \cos(\phi_S)}$$

$$6. \rightarrow A_{XI} = \frac{(E_0 + E_{180})/2 + 1}{A_{XV} \cos(\phi_S)}$$

Use above results along with  $E_{60}$  and  $E_{300}$  to calculate  $\phi_S$ .

$$7. E_{60} = \frac{IV A_{XV} A_{XI} \cos(60 - \phi_S)}{IV \cos(60)} - 1$$

$$= A_{XV} A_{XI} \cos(\phi_S) + A_{XV} A_{XI} \tan(60) \sin(\phi_S) - 1$$

$$8. E_{300} = \frac{IV A_{XV} A_{XI} \cos(-60 - \phi_S)}{IV \cos(-60)} - 1$$

$$= A_{XV} A_{XI} \cos(\phi_S) - A_{XV} A_{XI} \tan(60) \sin(\phi_S) - 1$$

Subtract 8 from 7

$$9. E_{60} - E_{300} = 2A_{XV} A_{XI} \tan(60) \sin(\phi_S)$$

use equation 5:

$$10. E_{60} - E_{300} = \frac{E_0 + E_{180} + 2}{\cos(\phi_S)} \tan(60) \sin(\phi_S)$$

$$11. E_{60} - E_{300} = (E_0 + E_{180} + 2) \tan(60) \tan(\phi_S)$$

$$12. \rightarrow \phi_S = \tan^{-1} \left( \frac{(E_{60} - E_{300})}{\tan(60)(E_0 + E_{180} + 2)} \right)$$

Now that we know the  $A_{XV}$ ,  $A_{XI}$ , and  $\phi_S$  errors, we calculate the new calibration voltage gain coefficient from the previous ones:

$$CAL\_V_{NEW} = \frac{CAL\_V}{A_{XV}}$$

We calculate PHADJ from  $\phi_S$ , the desired phase lag:

$$PHADJ = 2^{20} \left[ \frac{\tan(\phi_S) \left[ 1 + (1 - 2^{-9})^2 - 2(1 - 2^{-9}) \cos(2\pi f_0 T) \right]}{(1 - 2^{-9}) \sin(2\pi f_0 T) - \tan(\phi_S) \left[ 1 - (1 - 2^{-9}) \cos(2\pi f_0 T) \right]} \right]$$

And we calculate the new calibration current gain coefficient, including compensation for a slight gain increase in the phase calibration circuit.

$$CAL\_I_{NEW} = \frac{CAL\_I}{A_{XI}} \frac{1}{\sqrt{1 + \frac{2^{-20} PHADJ (2 + 2^{-20} PHADJ - 2(1 - 2^{-9}) \cos(2\pi f_0 T))}{1 - 2(1 - 2^{-9}) \cos(2\pi f_0 T) + (1 - 2^{-9})^2}}}$$

## 2.2 CALIBRATION PROCEDURES

Calibration requires that a calibration system is used, i.e. equipment that applies accurate voltage, load current and load angle to the unit being calibrated, while measuring the response from the unit being calibrated in a repeatable way. By repeatable we mean that the calibration system is synchronized to the meter being calibrated. Best results are achieved when the first pulse from the meter opens the measurement window of the calibration system. This mode of operation is opposed to a calibrator that opens the measurement window at random time and that therefore may or may not catch certain pulses emitted by the meter.

**It is essential for a valid meter calibration to have the voltage stabilized a few seconds before the current is applied. This enables the Demo Code to initialize the 71M6533 and to stabilize the PLLs and filters in the CE. This method of operation is consistent with meter applications in the field as well as with international metering standards.**

Each meter phase must be calibrated individually. The procedures below show how to calibrate a meter phase with either three or five measurements. The PHADJ equations apply only when a current transformer is used for the phase in question. Note that positive load angles correspond to lagging current (see Figure 2-2).

**During calibration of any phase, a stable mains voltage has to be present on phase A. This enables the CE processing mechanism of the 71M6533 necessary to obtain a stable calibration.**

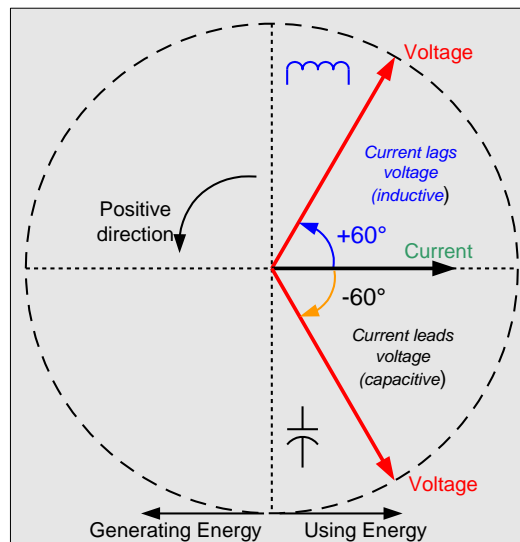

**Figure 2-2: Phase Angle Definitions**

The calibration procedures described below should be followed after interfacing the voltage and current sensors to the 71M6533 chip. When properly interfaced, the V3P3 power supply is connected to the meter neutral and is the DC reference for each input. Each voltage and current waveform, as seen by the 71M6533, is scaled to be less than 250mV (peak).

## 2.2.1 CALIBRATION PROCEDURE WITH THREE MEASUREMENTS

Each phase is calibrated individually. The calibration procedure is as follows:

- 1) The calibration factors for all phases are reset to their default values, i.e.  $CAL\_In = CAL\_Vn = 16384$ , and  $PHADJ\_n = 0$ .
- 2) An RMS voltage  $V_{ideal}$  consistent with the meter's nominal voltage is applied, and the RMS reading  $V_{actual}$  of the meter is recorded. The voltage reading error  $Axv$  is determined as

$$Axv = (V_{actual} - V_{ideal}) / V_{ideal}$$

- 3) Apply the nominal load current at phase angles  $0^\circ$  and  $60^\circ$ , measure the Wh energy and record the errors  $E_0$  AND  $E_{60}$ .
- 4) Calculate the new calibration factors  $CAL\_In$ ,  $CAL\_Vn$ , and  $PHADJ\_n$ , using the formulae presented in section 2.1.1 or using the spreadsheet presented in section 2.2.4.
- 5) Apply the new calibration factors  $CAL\_In$ ,  $CAL\_Vn$ , and  $PHADJ\_n$  to the meter. The memory locations for these factors are given in section 1.9.1.
- 6) Test the meter at nominal current and, if desired, at lower and higher currents and various phase angles to confirm the desired accuracy.
- 7) Store the new calibration factors  $CAL\_In$ ,  $CAL\_Vn$ , and  $PHADJ\_n$  in the EEPROM memory of the meter. If the calibration is performed on a Maxim's Teridian Demo Board, the methods involving the command line interface, as shown in sections 1.9.3 and 1.9.4, can be used.
- 8) Repeat the steps 1 through 7 for each phase.
- 9) For added temperature compensation, read the value  $TEMP\_RAW$  (CE RAM) and write it to  $TEMP\_NOM$  (CE RAM). If Demo Code 4.6n or later is used, this will automatically calculate the correction coefficients PPMC and PPMC2 from the nominal temperature and from the characterization data contained in the on-chip fuses.

**Tip: Step 2 and the energy measurement at  $0^\circ$  of step 3 can be combined into one step.**



## 2.2.2 CALIBRATION PROCEDURE WITH FIVE MEASUREMENTS

Each phase is calibrated individually. The calibration procedure is as follows:

- 1) The calibration factors for all phases are reset to their default values, i.e.  $CAL\_In = CAL\_Vn = 16384$ , and  $PHADJ\_n = 0$ .
- 2) An RMS voltage  $V_{ideal}$  consistent with the meter's nominal voltage is applied, and the RMS reading  $V_{actual}$  of the meter is recorded. The voltage reading error  $Axv$  is determined as
 
$$Axv = (V_{actual} - V_{ideal}) / V_{ideal}$$
- 3) Apply the nominal load current at phase angles  $0^\circ$ ,  $60^\circ$ ,  $180^\circ$  and  $-60^\circ$  ( $-300^\circ$ ). Measure the Wh energy each time and record the errors  $E_0$ ,  $E_{60}$ ,  $E_{180}$ , and  $E_{300}$ .
- 4) Calculate the new calibration factors  $CAL\_In$ ,  $CAL\_Vn$ , and  $PHADJ\_n$ , using the formulae presented in section 2.1.2 or using the spreadsheet presented in section 2.2.4.
- 5) Apply the new calibration factors  $CAL\_In$ ,  $CAL\_Vn$ , and  $PHADJ\_n$  to the meter. The memory locations for these factors are given in section 1.9.1.
- 6) Test the meter at nominal current and, if desired, at lower and higher currents and various phase angles to confirm the desired accuracy.
- 7) Store the new calibration factors  $CAL\_In$ ,  $CAL\_Vn$ , and  $PHADJ\_n$  in the EEPROM memory of the meter. If a Demo Board is calibrated, the methods involving the command line interface shown in sections 1.9.3 and 1.9.4 can be used.
- 8) Repeat the steps 1 through 7 for each phase.
- 9) For added temperature compensation, read the value  $TEMP\_RAW$  (CE RAM) and write it to  $TEMP\_NOM$  (CE RAM). If Demo Code 4.6n or later is used, this will automatically calculate the correction coefficients PPMC and PPMC2 from the nominal temperature and from the characterization data contained in the on-chip fuses.



**Tip: Step 2 and the energy measurement at  $0^\circ$  of step 3 can be combined into one step.**

## 2.2.3 CALIBRATION PROCEDURE FOR ROGOWSKI COIL SENSORS

Demo Code containing CE code that is compatible with Rogowski coils is available from MAXIM INTEGRATED PRODUCTS.

Rogowski coils generate a signal that is the derivative of the current. The CE code implemented in the Rogowski CE image digitally compensates for this effect and has the usual gain and phase calibration adjustments. Additionally, calibration adjustments are provided to eliminate voltage coupling from the sensor input.

Current sensors built from Rogowski coils have a relatively high output impedance that is susceptible to capacitive coupling from the large voltages present in the meter. The most dominant coupling is usually capacitance between the primary of the coil and the coil's output. This coupling adds a component proportional to the derivative of voltage to the sensor output. This effect is compensated by the voltage coupling calibration coefficients.

As with the CT procedure, the calibration procedure for Rogowski sensors uses the meter's display to calibrate the voltage path and the pulse outputs to perform the remaining energy calibrations. The calibration procedure must be done to each phase separately, making sure that the pulse generator is driven by the accumulated real energy for just that phase. In other words, the pulse generator input should be set to WhA, WhB, or WhC, depending on the phase being calibrated.

In preparation of the calibration, all calibration parameters are set to their default values.  $VMAX$  and  $IMAX$  are set to reflect the system design parameters.  $WRATE$  and  $PULSE\_SLOW$ ,  $PULSE\_FAST$  are adjusted to obtain the desired Kh.

**Step 1: Basic Calibration:** After making sure  $VFEED\_A$ ,  $VFEED\_B$ , and  $VFEED\_C$  are zero, perform either the three measurement procedure (2.2.1) or the five measurement calibration procedure (2.2.2) described in the CT section. Perform the procedure at a current large enough that energy readings are immune from voltage coupling effects.

The one exception to the CT procedure is the equation for PHADJ—after the phase error,  $\phi_s$ , has been calculated, use the PHADJ equation shown below. Note that the default value of PHADJ is not zero, but rather -3973.

$$PHADJ = PHADJ_{PREVIOUS} - \phi_s 1786 \frac{50}{f_0}$$

If voltage coupling at low currents is introducing unacceptable errors, perform step 2 below to select non-zero values for  $VFEED\_A$ ,  $VFEED\_B$ , and  $VFEED\_C$ .

**Step 2: Voltage Cancellation:** Select a small current,  $I_{RMS}$ , where voltage coupling introduces at least 1.5% energy error. At this current, measure the errors  $E_0$  and  $E_{180}$  to determine the coefficient  $VFEED$ .

$$VFEED = \frac{E_0 - E_{180}}{2} 2^{25} \frac{I_{RMS} V_{MAX}}{I_{MAX} V_{RMS}} - VFEED_{PREVIOUS}$$

## 2.2.4 CALIBRATION SPREADSHEETS

Calibration spreadsheets are available from MAXIM INTEGRATED PRODUCTS. They are also included in the CD-ROM shipped with any Demo Kit. Figure 2-3 shows the spreadsheet for three measurements. Figure 2-4 shows the spreadsheet for five measurements with three phases.

For CT and shunt calibration, data should be entered into the calibration spreadsheets as follows:

1. Calibration is performed one phase at a time.
2. Results from measurements are generally entered in the yellow fields. Intermediate results and calibration factors will show in the green fields.
3. The line frequency used (50 or 60 Hz) is entered in the yellow field labeled AC frequency.
4. After the voltage measurement, measured (observed) and expected (actually applied) voltages are entered in the yellow fields labeled "Expected Voltage" and "Measured Voltage". The error for the voltage measurement will then show in the green field above the two voltage entries.
5. The relative error from the energy measurements at 0° and 60° are entered in the yellow fields labeled "Energy reading at 0°" and "Energy reading at 60°". The corresponding error, expressed as a fraction will then show in the two green fields to the right of the energy reading fields.
6. The spreadsheet will calculate the calibration factors  $CAL\_IA$ ,  $CAL\_VA$ , and  $PHADJ\_A$  from the information entered so far and display them in the green fields in the column underneath the label "new".
7. If the calibration was performed on a meter with non-default calibration factors, these factors can be entered in the yellow fields in the column underneath the label "old".  
For a meter with default calibration factors, the entries in the column underneath "old" should be at the default value (16384).

A spreadsheet is also available for Rogowski coil calibration (see Figure 2-5). Data entry is as follows:

1. All nominal values are entered in the fields of step one.
2. The applied voltage is entered in the yellow field labeled "Input Voltage Applied" of step 2. The entered value will automatically show in the green fields of the two other channels.
3. After measuring the voltages displayed by the meter, these are entered in the yellow fields labeled "Measured Voltage". The spreadsheet will show the calculated calibration factors for voltage in the green fields labeled "CAL\_Vx".
4. The default values (-3973) for PHADJ\_x are entered in the yellow fields of step 3. If the calibration factors for the current are not at default, their values are entered in the fields labeled "Old CAL\_Ix".
5. The errors of the energy measurements at 0°, 60°, -60°, and 180° are entered in the yellow fields labeled "% Error ...". The spreadsheet will then display phase error, the current calibration factor and the PHADJ\_x factor in the green fields, one for each phase.
6. If a crosstalk measurement is necessary, it should be performed at a low current, where the effects of crosstalk are noticeable. First, if (old) values for VFEEDEX exist in the meter, they are entered in the spreadsheet in the row labeled "Old VFEEDEX", one for each phase. If these factors are zero, "0" is entered for each phase.
7. Test current and test voltage are entered in the yellow fields labeled VRMS and IRMS.
8. The crosstalk measurement is now conducted at a low current with phase angles of 0° and 180°, and the percentage errors are entered in the yellow fields labeled "% error, 0 deg" and "% error, 180 deg", one pair of values for each phase. The resulting VFEEDEX factors are then displayed in the green fields labeled VFEEDEX.



**71M6511/71M6513/71M6515 Calibration Worksheet**  
*Three Measurements*

Enter values in yellow fields

Results will show in green fields...

**AC frequency:** 50 [Hz]  
(click on yellow field to select from pull-down list)

PHASE A	%	fraction		
Energy reading at 0°	0	0	old	new
Energy reading at +60°	0	0	CAL_IA	16384
Voltage error at 0°	0	0	CAL_VA	16384
			PHADJ_A	0
Expected voltage	240	[V]		
Measured voltage	240	[V]		

PHASE B	%	fraction		
Energy reading at 0°	10	0.1	old	new
Energy reading at +60°	10	0.1	CAL_IB	16384
Voltage error at 0°	10	0.1	CAL_VB	16384
			PHADJ_B	0
Expected voltage	240	[V]		
Measured voltage	264	[V]		

  

PHASE C	%	fraction		
Energy reading at 0°	-3.8	-0.038	old	new
Energy reading at +60°	-9	-0.09	CAL_IC	16384
Voltage error at 0°	-3.8	-0.038	CAL_VC	17031
			PHADJ_C	-5597
Expected voltage	240	[V]		
Measured voltage	230.88	[V]		

REV: 4.2

Date: 10/25/2005

Author: WJH

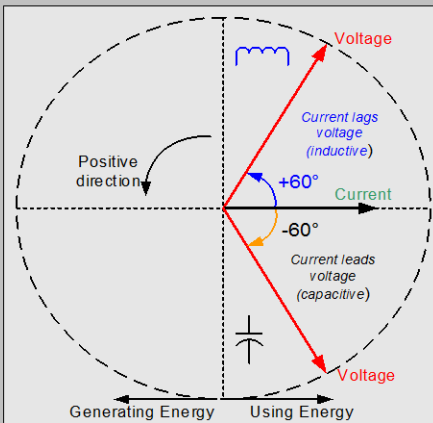

Readings: Enter 0 if the error is 0%,  
enter -3 if meter runs 3% slow.

Figure 2-3: Calibration Spreadsheet for Three Measurements



**71M6511/71M6513/71M6515 Calibration Worksheet**  
*Five Measurements*

AC frequency:  [Hz]  
*(click on yellow field to select from pull-down list)*

**REV 4.2**  
**Date: 10/25/2005**  
**Author: WJH**

*Results will show in green fields...*  
*Enter values in yellow fields!*

PHASE A			old	new
Energy reading at 0°	2	0.02	CAL_IA 16384	16220
Energy reading at +60°	2.5	0.025	CAL_VA 16384	16222
Energy reading at -60°	1.5	0.015	PHADJ_A	371
Energy reading at 180°	2	0.02		
Voltage error at 0°	1	0.01		
Expected voltage [V]	240	242.4	Measured voltage [V]	

PHASE B			old	new
Energy reading at 0°	2	0.02	CAL_IB 16384	16223
Energy reading at +60°	2	0.02	CAL_VB 16384	16222
Energy reading at -60°	2	0.02	PHADJ_B	0
Energy reading at 180°	2	0.02		
Voltage error at 0°	1	0.01		
Expected voltage [V]	240	242.4	Measured voltage [V]	

PHASE C			old	new
Energy reading at 0°	0	0	CAL_IC 16384	16384
Energy reading at +60°	0	0	CAL_VC 16384	16384
Energy reading at -60°	0	0	PHADJ_C	0
Energy reading at 180°	0	0		
Voltage error at 0°	0	0		
Expected voltage [V]	240	240	Measured voltage [V]	

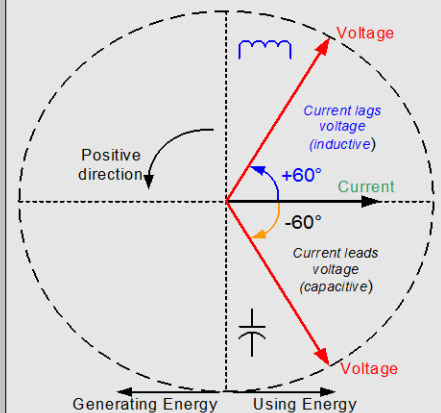

Readings: Enter 0 if the error is 0%,  
 enter +5 if meter runs 5% fast,  
 enter -3 if meter runs 3% slow.

Figure 2-4: Calibration Spreadsheet for Five Measurements

### Calibration Procedure for Rogowski Coils

Enter values in yellow fields!

Results will show in green fields...



Step 1: Enter Nominal Values:		Resulting Nominal		REV	4.3
Nominal CAL_V	16384	Values: X	6	Date:	11/18/2005
Nominal CAL_I	16384	Kh (Wh)	0.440	Author:	WJH
PHADJ	-3973	Angle Sensitivity (deg/LSB) 50Hz 5.60E-04			
WRATE	179				
VMAX	600				
Calibration Frequency [Hz]	50				
IMAX (incl. ISHUNT)	30.000				
PULSE_FAST	-1				
PULSE_SLOW	-1				
NACC	2520				

Step 2: VRMS Calibration:	Phase A	Phase B	Phase C
Enter old CAL_VA	16384	16384	16384
Input Voltage Applied	240	240	240
Measured Voltage	235.612	236.55	234.72
CAL_Vx	16689	16623	16753

Step 3: Current Gain and Phase Calibration	Deg/ct 5.60E-04		
	Phase A	Phase B	Phase C
old PHADJ	-3973	-3973	-3973
Old CAL_Ix	16384	16384	16384
%Error, 60°	-3.712	-3.912	-5.169
%Error, -60°	-3.381	-2.915	-4.241
%Error, 0°	-3.591	-3.482	-4.751
%Error, 180°	-3.72	-3.56	-4.831
Phase Error (°)	0.0547319	0.1647659	0.1533716
PHADJ	-4070.74	-4267.22	-4246.88
CAL_Ix	17005.641	16981.934	17208.457

Step 4: Crosstalk Calibration (Equalize Gain for 0° and 180°)			
VRMS	240		
IRMS	0.30		
	Phase A	Phase B	Phase C
Old VFEEDx	0	0	0
% Error, 0deg	1.542	1.61	1.706
%Error, 180deg	-1.634	-1.743	-1.884
VFEEDx	-13321	-14064	-15058

1. Rogowski coils have significant crosstalk from voltage to current. This contributes to gain and phase errors.
2. Therefore, before calibrating a Rogowski meter, a quick 0° load line should be run to determine at what current the crosstalk contributes at least 1% error.
3. Crosstalk calibration should be performed at this current or lower.
4. If crosstalk contributes an E0 error at current Ix, there will be a 0.1% error in E60 at 15\*Ix.

Figure 2-5: Calibration Spreadsheet for Rogowski coil

## 2.2.5 COMPENSATING FOR NON-LINEARITIES

Nonlinearity is most noticeable at low currents, as shown in Figure 2-6, and can result from input noise and truncation. Nonlinearities can be eliminated using the *QUANT* variable.

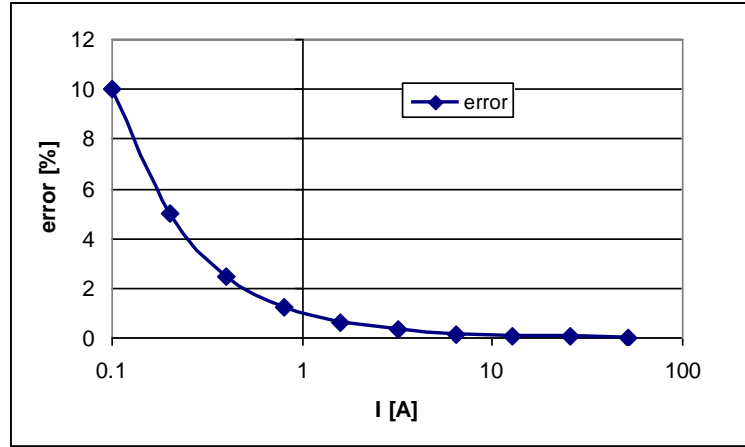

**Figure 2-6: Non-Linearity Caused by Quantification Noise**

The error can be seen as the presence of a virtual constant noise current. While 10mA hardly contribute any error at currents of 10A and above, the noise becomes dominant at small currents.

The value to be used for *QUANT* can be determined by the following formula:

$$QUANT = -\frac{\frac{error}{100} \cdot V \cdot I}{VMAX \cdot IMAX \cdot LSB}$$

Where error = observed error at a given voltage (V) and current (I),  
 VMAX = voltage scaling factor, as described in section 1.8.3,  
 IMAX = current scaling factor, as described in section 1.8.3,  
 LSB = QUANT LSB value =  $1.04173 \cdot 10^{-9} W$

Note: The LSB value for *QUANT* will depend on the CE code that is used for the application. Check the CE code specification for the actual LSB value.

Example: Assuming an observed error as in Figure 2-6, we determine the error at 1A to be +1%. If VMAX is 600V, IMAX = 208A,  $QUANT \text{ LSB} = 7.4162 \cdot 10^{-10}$ , and if the measurement was taken at 240V, we determine *QUANT* as follows:

$$QUANT = -\frac{\frac{1}{100} \cdot 240 \cdot 1}{600 \cdot 208 \cdot 7.4162 \cdot 10^{-10}} = -11339$$

*QUANT* is to be written to the CE location given in the data sheet or in the CE code specification. It does not matter which current value is chosen as long as the corresponding error value is significant (5% error at 0.2A used in the above equation will produce the same result for *QUANT*).

Input noise and truncation can cause similar errors in the VAR calculation that can be eliminated using the *QUANT\_VAR* variable. *QUANT\_VAR* is determined using the same formula as *QUANT*.

## 2.3 POWER SAVING MEASURES

In many cases, especially when operating the 71M6533 from a battery, it is desirable to reduce the power consumed by the chip to a minimum. This can be achieved with the measures listed in Table 2-1.

Power Saving Measure	Software Control	Typical Savings
Disable the CE	$CE\_EN = 0$	0.16mA
Disable the ADC	$ADC\_DIS = 1$	1.8mA
Disable clock test output CKTEST	$CKOUTDIS = 1$	0.6mA
Disable emulator clock	$ECK\_DIS = 1$	0.1mA
Disable RTM outputs	$RTM\_EN = 0$	0.01mA
Disable SSI output	$SSI\_EN = 0$	
Select DGND for the multiplexer input	$TMUX[3:0] = 0$	
Disable reference voltage output	$VREF\_DIS = 1$	
Reduce the clock for the MPU	$MPU\_DIV = 5$	0.4mA

Table 2-1: Power Saving Measures

## 2.4 SCHEMATIC INFORMATION

In this section, hints on proper schematic design are provided that will help designing circuits that are functional and sufficiently immune to EMI (electromagnetic interference).

### 2.4.1 COMPONENTS FOR THE V1 PIN

The V1 pin of the 71M6533 can never be left unconnected.

A voltage divider should be used to establish that V1 is in a safe range when the meter is in mission mode (V1 must be lower than 2.9V in all cases in order to keep the hardware watchdog timer enabled). For proper debugging or loading code into the 71M6533 mounted on a PCB, it is necessary to have a provision like the header JP1 shown above R1 in Figure 2-7. A shorting jumper on this header pulls V1 up to V3P3 disabling the hardware watchdog timer.

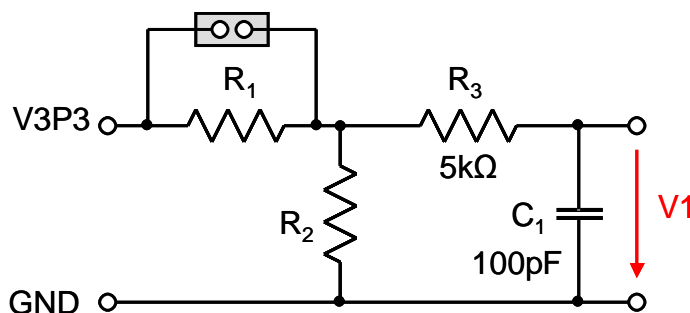

Figure 2-7: Voltage Divider for V1

On the 71M6533-DB Demo Board this feature is implemented with resistors R83/R86, capacitor C31 and TP10. See the board schematics in the Appendix for details.

### 2.4.2 RESET CIRCUIT

Even though a functional meter will not necessarily need a reset switch, the 71M6533-DB Demo Boards provide a reset pushbutton that can be used when prototyping and debugging software (see Figure 2-8).. For a production meter, the RESET pin should be pulled down hard to GNDD.

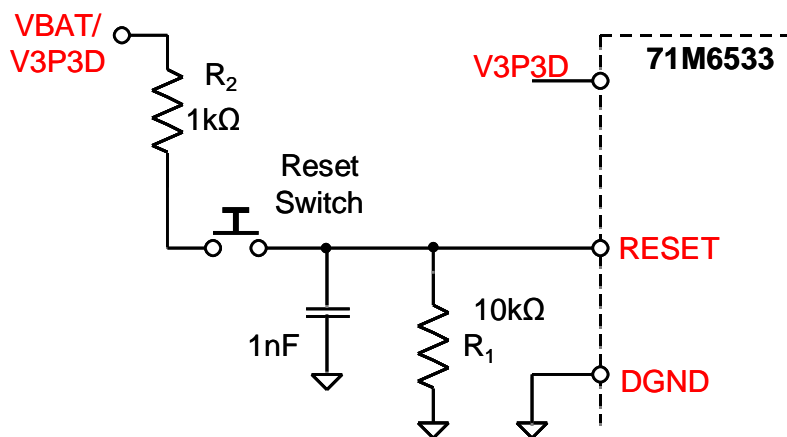

Figure 2-8: External Components for RESETZ

### 2.4.3 OSCILLATOR

The oscillator of the 71M6533 drives a standard 32.768kHz watch crystal (see Figure 2-9). Crystals of this type are accurate and do not require a high-current oscillator circuit. The oscillator in the 71M6533 has been designed specifically to handle watch crystals and is compatible with their high impedance and limited power handling capability. The oscillator power dissipation is very low to maximize the lifetime of any battery backup device attached to the VBAT pin.

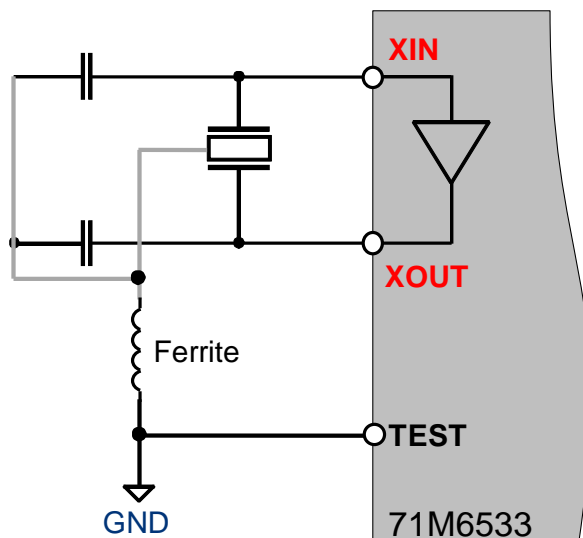

Figure 2-9: Oscillator Circuit



It is not necessary to place an external resistor across the crystal

For better resistance to EMI, the GND connection for the capacitors should be through a ferrite bead.

### 2.4.4 EEPROM

EEPROMs should be connected to the pins DIO4 and DIO5 (see Figure 2-10). These pins can be switched from regular DIO to implement an I2C interface by setting the I/O RAM register DIO\_EEX (0x2008[4]) to 1. Pull-up resistors of 3kΩ must be provided for both the SCL and SDA signals.

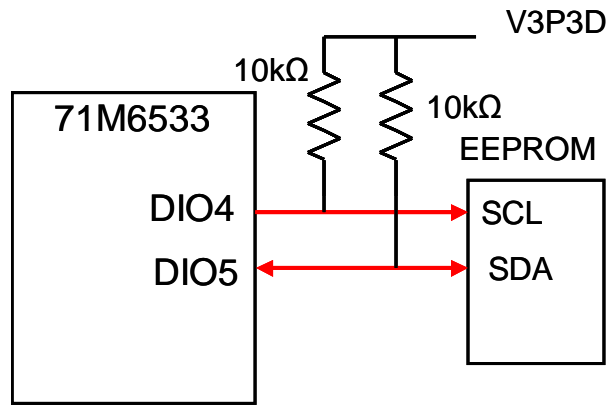

Figure 2-10: EEPROM Circuit

## 2.4.5 LCD

The 71M6533 has an on-chip LCD controller capable of controlling static or multiplexed LCDs. Figure 2-11 shows the basic connection for LCDs. Note that the LCD module itself has no power connection.

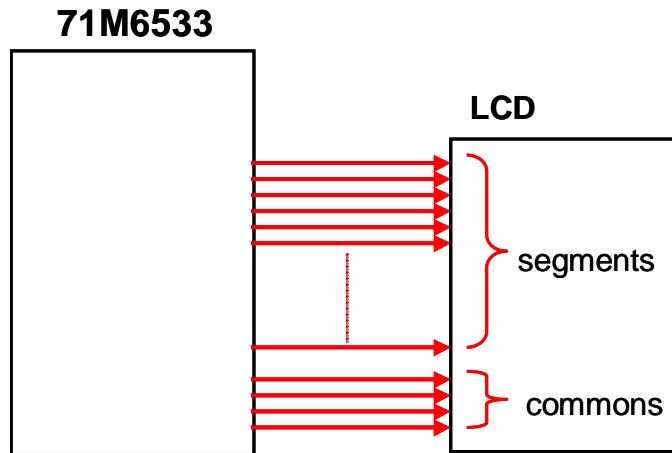
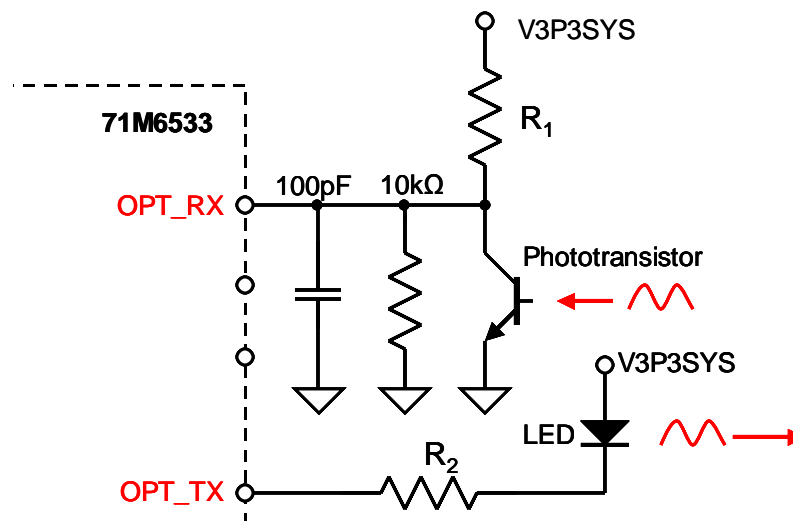

Figure 2-11: LCD Connections

## 2.4.6 OPTICAL INTERFACE

The 71M6533 IC is equipped with two pins supporting the optical interface: OPT\_TX and OPT\_RX. The OPT\_TX pin can be used to drive a visual or IR light LED with up to 20mA, a series resistor ( $R_2$  in Figure 2-12) helps limiting the current). The OPT\_RX pin can be connected to the collector of a photo-transistor, as shown in Figure 2-12.



**Figure 2-12: Optical Interface Block Diagram**

The IR diode should be connected between terminal 2 of header J12 on the Demo Board (cathode) and the V3P3 voltage (anode), which is accessible at terminal 1 of header J12 (see Figure 3).

J12 on the 71M6533-DB Demo Boards has all the provisions for connecting the IR LED and photo-transistor.

## 2.4.7 FERRITES

Ferrite beads on the PCB are useful for the rejection of noise and general EMI events such as ESD and EFT. Some precautions apply:

- 1) Ferrites should not be placed upstream from MOVs, TVS, and other clamping devices, since large currents will flow through the ferrites in the event of a surge. If the ferrite is not designed for large surge currents, it will burn up.
- 2) Placing ferrite beads directly in series with the ADC inputs of the 71M6533 can cause inaccuracies in Wh readings over temperature. Ferrites should be placed before the balance resistor and reservoir capacitor. For details, see Maxim Application Note AN-5292.

## 2.5 TESTING THE DEMO BOARD

This section will explain how the 71M6533 IC and the peripherals can be tested. Hints given in this section will help evaluating the features of the Demo Board and understanding the IC and its peripherals.

### 2.5.1 FUNCTIONAL METER TEST

This is the test that every Demo Board has to pass before being integrated into a Demo Kit. Before going into the functional meter test, the Demo Board has already passed a series of bench-top tests, but the functional meter test is the first test that applies realistic high voltages (and current signals from current transformers) to the Demo Board.

Figure 2-13 shows a meter connected to a typical calibration system. The calibrator supplies calibrated voltage and current signals to the meter. It should be noted that the current flows through the CT or CTs that are not part of the Demo Board. The Demo Board rather receives the voltage output signals from the CT. An optical pickup senses the pulses emitted by the meter and reports them to the calibrator. Some calibration systems have electrical pickups. The calibrator measures the time between the pulses and compares it to the expected time, based on the meter  $K_h$  and the applied power.

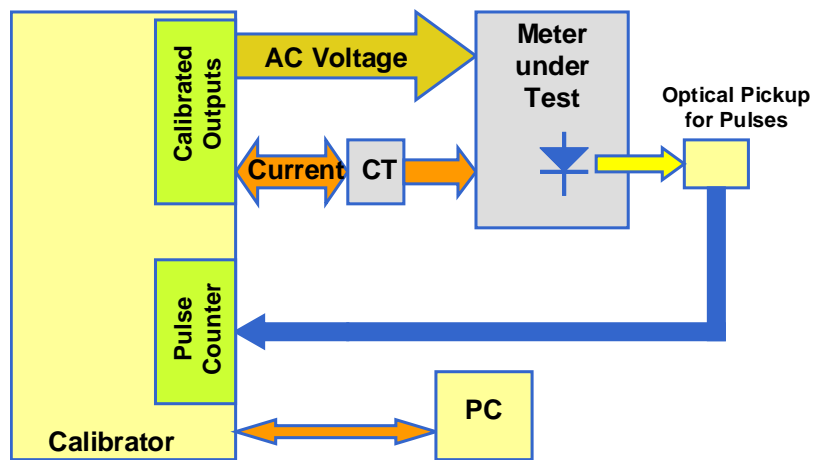

Figure 2-13: Meter with Calibration System

Maxim's Teridian Demo Boards are not calibrated prior to shipping. However, the Demo Board pulse outputs are tested and compared to the expected pulse output rate. Figure 2-14 shows the screen on the controlling PC for a typical Demo Board. The error numbers are given in percent. This means that for the measured Demo Board, the sum of all errors resulting from tolerances of PCB components, CTs, and 71M6533 tolerances was -3.41%, a range that can easily be compensated by calibration.

Figure 2-15 shows a load-line obtained with a 6533 in differential mode. As can be seen, dynamic ranges of 10,000:1 for current can be achieved with good circuit design, layout, cabling, and, of course, good current sensors.

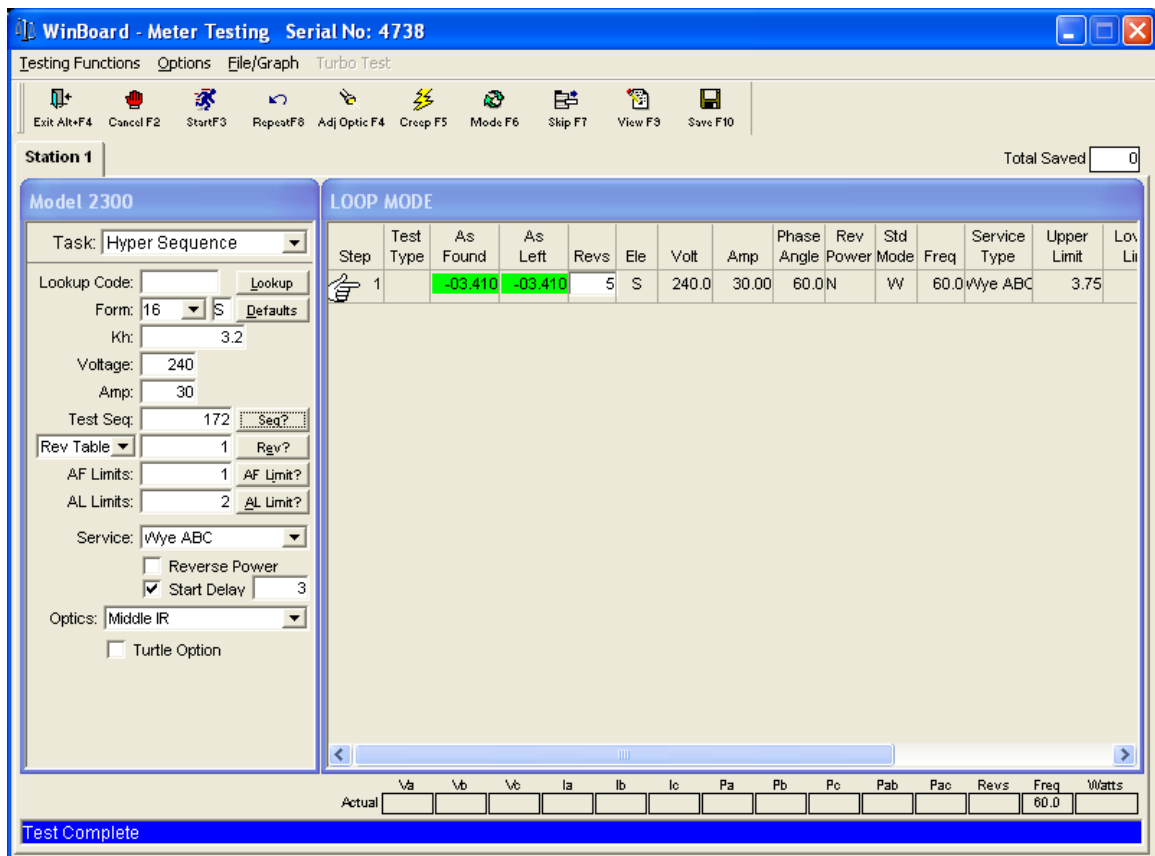
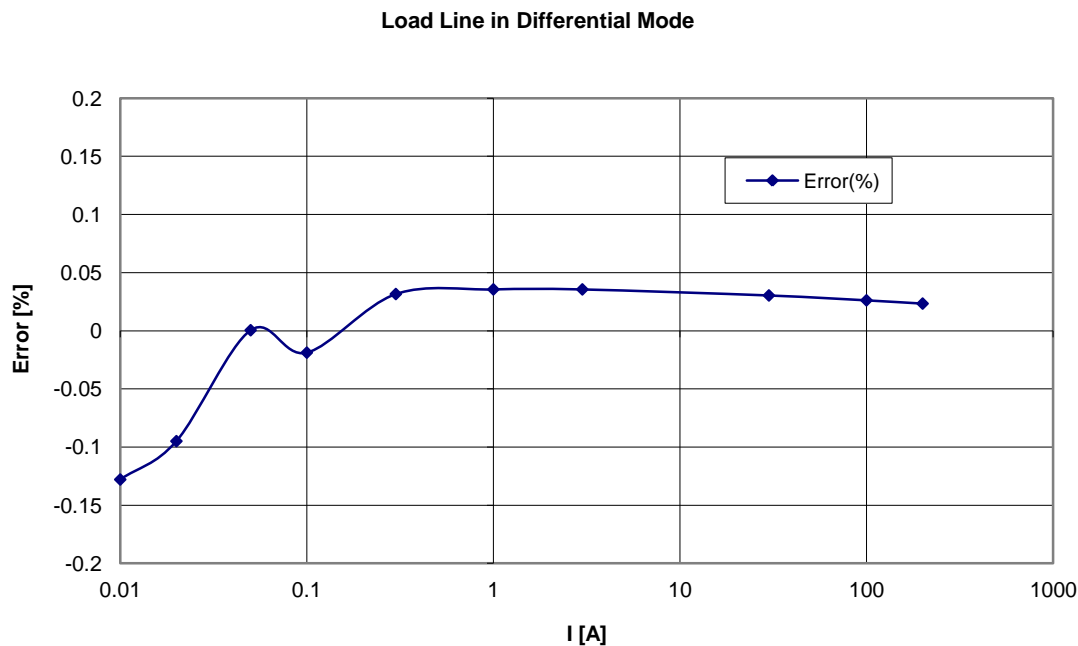

Figure 2-14: Calibration System Screen



**Figure 2-15: Wh Load Line in Differential Mode at Room Temperature**

## 2.5.2 EEPROM

Testing the EEPROM provided on the Demo Board is straightforward and can be done using the serial command line interface (CLI) of the Demo Code.

To write a string of text characters to the EEPROM and read it back, we apply the following sequence of CLI commands:

```

>EEC1                Enables the EEPROM
>EESthis is a test   Writes text to the buffer
>EET80               Writes buffer to address 80

Written to EEPROM address 00000080 74 68 69 73 20 69 73 20 61 ....
Response from Demo Code
>EER80.E             Reads text from the buffer

Read from EEPROM address 00000080 74 68 69 73 20 69 73 20 61 ....
Response from Demo Code
>EEC0                Disables the EEPROM

```

## 2.5.3 RTC

Testing the RTC inside the 71M6533 IC is straightforward and can be done using the serial command line interface (CLI) of the Demo Code.

To set the RTC and check the time and date, we apply the following sequence of CLI commands:

```

>M10                 LCD display to show calendar date
>RTD05.09.27.3      Sets the date to 9/27/2005 (Tuesday)
>M9                  LCD display to show time of day
>RTT10.45.00        Sets the time to 10:45:00. AM/PM distinction: 1:22:33PM = 13:22:33

```

## 2.5.4 HARDWARE WATCHDOG TIMER

The hardware watchdog timer of the 71M6533 is disabled when the voltage at the V1 pin is at 3.3V (V3P3). On the Demo Boards, this is done by plugging in a jumper at TP10 between the V1 and V3P3 pins.



**Programming the flash memory or emulation using the ADM51 In-Circuit-Emulator can only be done when a jumper is plugged in at TP10 between V1 and V3P3.**

Conversely, removing the jumper at TP10 will enable the hardware watchdog timer.

## 2.5.5 LCD

Various tests of the LCD interface can be performed with the Demo Board, using the serial command line interface (CLI):

Setting the *LCD\_EN* register to 1 enables the display outputs.

Register Name	Address [bits]	R/W	Description
<i>LCD_EN</i>	2021[5]	R/W	Enables the LCD display. When disabled, VLC2, VLC1, and VLC0 are ground as are the COM and SEG outputs.

To access the *LCD\_EN* register, we apply the following CLI commands:

```
>RI21$      Reads the hex value of register 0x2021
>25        Response from Demo Code indicating the bit 5 is set
>RI21=5     Writes the hex value 0x05 to register 0x2021 causing the display to be switched off
>RI21=25    Sets the LCD_EN register back to normal
```

The 71M6533 provides a charge pump capable of boosting the 3.3VDC supply voltage up to 5.0VDC. The boost circuit is enabled with the *LCD\_BSTEN* register. The 6533 Demo Boards have the boost circuit enabled by default.

Register Name	Address [bits]	R/W	Description
<i>LCD_BSTEN</i>	2020[7]	R/W	Enables the LCD voltage boost circuit.

To disable the LCD voltage boost circuit, we apply the following CLI commands:

```
>RI20$      Reads the hex value of register 0x2020
>8E        Response from Demo Code indicating the bit 7 is set
>RI20=E     Writes the hex value 0x0E to register 0x2020 causing the LCD boost to be switched off
>RI20=8E    Enables the LCD boost circuit
```

The *LCD\_CLK* register determines the frequency at which the COM pins change states. A slower clock means lower power consumption, but if the clock is too slow, visible flicker can occur. The default clock frequency for the 71M6533-DB Demo Boards is 150Hz (*LCD\_CLK* = 01).

Register Name	Address [bits]	R/W	Description
<i>LCD_CLK</i> [1:0]	2021[1:0]	R/W	Sets the LCD clock frequency, i.e. the frequency at which SEG and COM pins change states. $f_w = \text{CKADC}/128 = 38,400$  00: $f_w/2^9$ , 01: $f_w/2^8$ , 10: $f_w/2^7$ , 11: $f_w/2^6$

To change the LCD clock frequency, we apply the following CLI commands:

```
>RI21$      Reads the hex value of register 0x2021
>25        Response from Demo Code indicating the bit 0 is set and bit 1 is cleared.
>RI21=24    Writes the hex value 0x24 to register 0x2021 clearing bit 0 – LCD flicker is visible now
```

>**RI21=25**      Writes the original value back to *LCD\_CLK*

## 2.6 APPLICATION NOTES

Please check on the Maxim web site or contact your local Maxim Integrated Products sales representative for Application Notes.



## 3

## 3 HARDWARE DESCRIPTION

### 3.1 71M6533-DB DEMO BOARD DESCRIPTION: JUMPERS, SWITCHES AND TEST POINTS

The items described in the following tables refer to the flags in Figure 3-1.



Item #	Reference Designator	Name	Use
1, 2, 6	TP2, TP4, TP6	VA, VB, VC	Two-pin header test points. One pin is the VA, VB, or VC line voltage input to the IC and the other end is V3P3.
4	JP1	PS_SEL[0] 	A jumper is placed across JP1 to activate the internal power supply. JP1 is on the bottom of the board. <b>Caution: High Voltage! Do not touch!</b>
3, 8, 11	J4, J6, J8	VA_IN, VB_IN, VC_IN 	VA_IN, VB_IN, and VC_IN are the line voltage inputs to the board. Each input has a resistor divider that leads to the pin on the IC associated with the voltage input to the ADC. These inputs are spade terminals mounted on the bottom of the board. <b>Caution: High Voltage! Do not touch these pins!</b>
5	J9	NEUTRAL	The NEUTRAL voltage input connected to V3P3. This input is a spade terminal mounted on the bottom of the board.
7	SW2	RESET	Chip reset switch: When the switch is pressed, the RESET pin of the IC is pulled high which resets the IC into a known state.
9	JP8	VBAT, GND	Three-pin header that allows selection of power to the VBAT pin. When the jumper is placed between pins 1 and 2 ( <b>default setting of demo board</b> ) VBAT is tied to the IC supply. An external battery can be connected between terminals 2 and 3.
10	SW3	PB	Pushbutton connected to the PB pin on the IC. This pushbutton can be used in conjunction with the Demo Code to wake the IC from sleep mode or LCD mode to brown-out mode. In mission mode, the pushbutton serves to cycle the LCD display.

Table 3-1: 71M6533-DB Demo Board Description

Item #	Reference Designator	Name	Use
12	J12	OPT_RX, VBAT, OPT_TX, GND	Five-pin header for access to the optical port (UART1). Terminal 2 monitors the TX_OPT output of the IC. Terminal 4 monitors the OPT_RX input to the IC. <b>No jumper should be place across VBAT and OPT_TX_OUT</b>
13	J1	5 Volt external supply	Plug for connecting the external 5 VDC power supply.
14, 20, 24, 32	TP13, TP14, TP15, TP16	GND	GND test points.
15	JP20	--	Two-pin header for selecting the signal for the pulse LED (D6). With a jumper between pins 1 and 2, RPULSE is selected. Pins 2 and 3 select YPULSE.
16	D6	VARs	VARh pulse LED.
17	TP21	--	Two-pin header providing access to the signals powering the RPULSE LED (D5).
18	JP19	SEG21/DIO08	Two-pin header for selecting the signal for the pulse LED (D5). With a jumper between pins 1 and 2, WPULSE is selected. Pins 2 and 3 select XPULSE.
19	TP20	--	Two-pin header providing access to the signals powering the WPULSE LED (D6).
21	D5	WATTS	Wh pulse LED.
22	JP16	BAT MODE	Selector for the operation of the IC when main power is removed. A jumper across pins 2-3 (default) indicates that no external battery is available. The IC will stay in brownout mode when the system power is down and it will communicate at 9600bd. A jumper across pins 1-2 indicates that an external battery is available. The IC will be able to transition from brownout mode to sleep and LCD modes when the system power is down and it will communicate at 300bd.
23	JP6	DIO03_R	Three-pin header providing access to DIO03.
25	JP7	ICE_EN	To enable the ICE interface a jumper is installed across pins 2 and 3.
26	U8	--	LCD display – eight digits, 14 segments.
27	JP13, JP14, JP15	DIO56, DIO57, DIO58	Two-pin headers providing access to the DIO signals DIO56, DIO57, and DIO58.
28	J2	DEBUG	Connector for USB-Serial Adapter. 2x8 pin male header.
29	U5	--	The IC 71M6533 soldered to the PCB.
30	TP8	CKTEST, TMUXOUT	Test points for access to the CKTEST and TMUXOUT pins on the IC.
31	TP17	VREF	Test point for access to the VREF pin on the IC.
33	TP10	V1_R	Three-pin header for control of the V1 input to the IC.
34	J18	--	SPI interface connector.
35, 39, 41, 43	J19, J20, J21, J22	IAN/IAP, IBN/IBP, ICN/ICP, IDP	Two-pin headers for monitoring the current channel inputs.
36	J14	EMULATOR I/F	2x10 emulator connector port for the Signum ICE ADM-51 or for the TFP2 Flash Programmer.

Table 3-2: 71M6533-DB Demo Board Description

Item #	Reference Designator	Name	Use
37	J17	--	Alternative connector for the ICE interface.
38, 40, 42, 44	J3, J5, J7, J10	--	Two-pin headers mounted on the bottom of the board. The outputs from the CTs are to be connected here.

Table 3-3: 71M6533-DB Demo Board Description

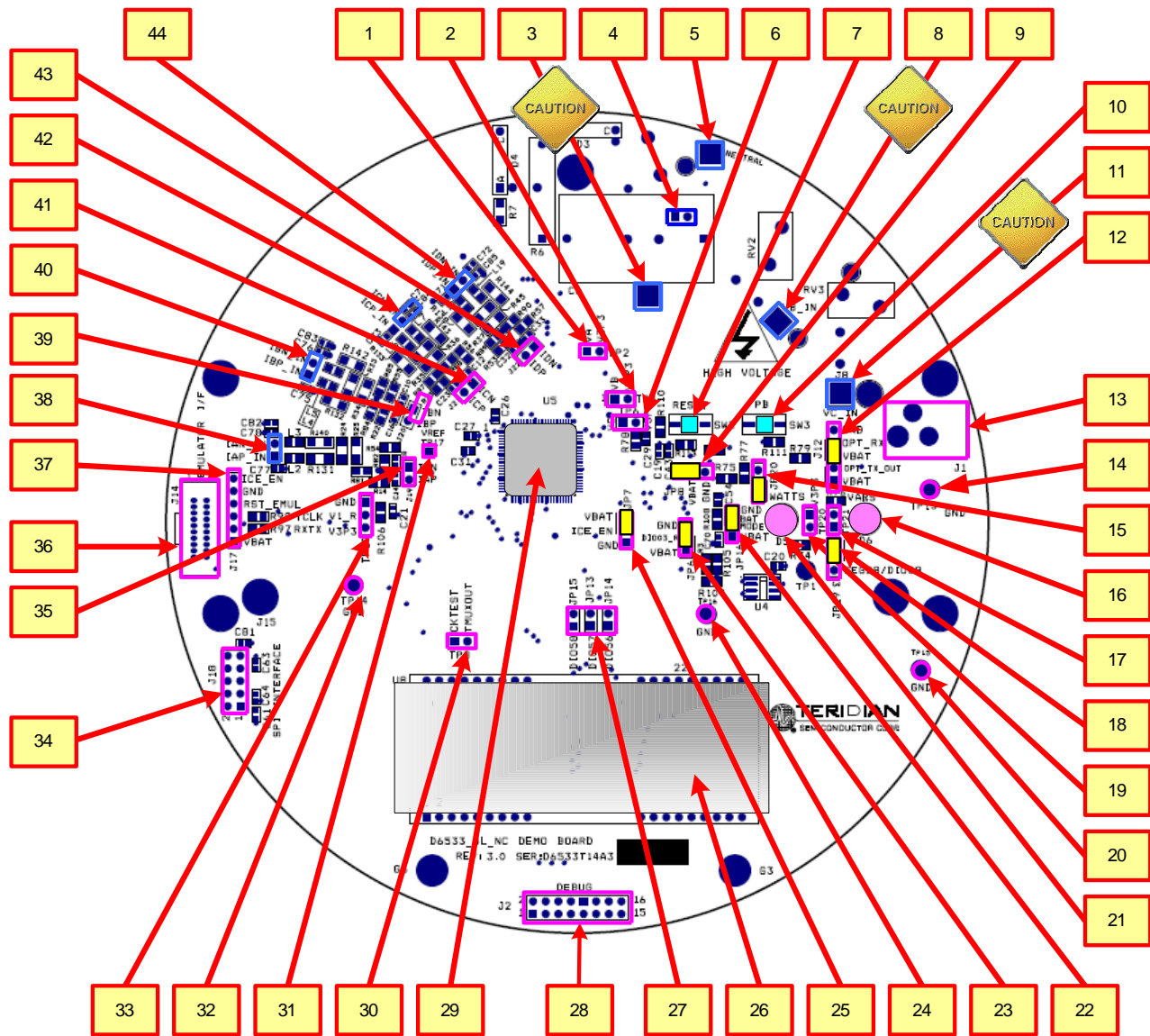

Figure 3-1: 71M6533-DB Demo Board - Board Description

(Default jumper settings indicated in yellow)

## 3.2 BOARD HARDWARE SPECIFICATIONS

### PCB Dimensions

- Diameter 6.5" (165.1mm)
- Thickness 0.062" (1.6mm)
- Height w/ components 1.5" (38.1mm)

### Environmental

- Operating Temperature -40°...+85°C  
(function of crystal oscillator affected outside -10°C to +60°C)
- Storage Temperature -40°C...+100°C

### Power Supply

- Using internal AC supply 240V...700V RMS
- DC Input Voltage (powered from DC supply) 5VDC  $\pm$ 0.5V
- Supply Current 25mA typical

### Input Signal Range

- AC Voltage Signals (VA, VB, VC) 0...240V RMS
- AC Current Signals (IA, IB, IC) from CT 0...0.25V p/p (176mV RMS)

### Interface Connectors

- DC Supply Jack (J1) to Wall Transformer Concentric connector, 2.5mm
- Emulator (J14 and J17) 10x2 header, 0.05" pitch and 6x1 header, 0.1" pitch
- Voltage Input Signals Spade terminals on PCB bottom
- Current Input Signals 0.1" headers on PCB bottom
- USB-Serial Adapter (J2) 8x2 header, 0.1" pitch
- SPI Interface 5x2 header, 0.1" pitch

### Functional Specification

- Program Memory 128KByte FLASH memory
- NV memory 1Mbit serial EEPROM
- Time Base Frequency 32.768kHz,  $\pm$ 20PPM at 25°C
- Time Base Temperature Coefficient -0.04PPM/°C<sup>2</sup> (max)

### Controls and Displays

- Reset Push-button (SW2)
- PB Push-button (SW3)
- Numeric Display 8-digit LCD, 14-segments per digit
- "Watts" red LED (D5)
- "VARS" red LED (D6)

### Measurement Range

- Voltage 120...700 V rms (resistor division ratio 1:3,398)
- Current 1.7 $\Omega$  termination for 2,000:1 CT input (208A)



## 4 APPENDIX

This appendix includes the following documentation, tables and drawings:

### **71M6533-DB Demo Board Description**

- 71M6533-DB Demo Board Electrical Schematic
- 71M6533-DB Demo Board Bill of Materials
- 71M6533-DB Demo Board PCB layers (copper, silk screen, top and bottom side)
- 71M6533-DB Demo Board Electrical Schematic

### **71M6533/71M6533H IC Description**

- 71M6533/71M6533H Pin Description
- 71M6533/71M6533H Pin-out

## 4.1 71M6533-DB DEMO BOARD ELECTRICAL SCHEMATIC

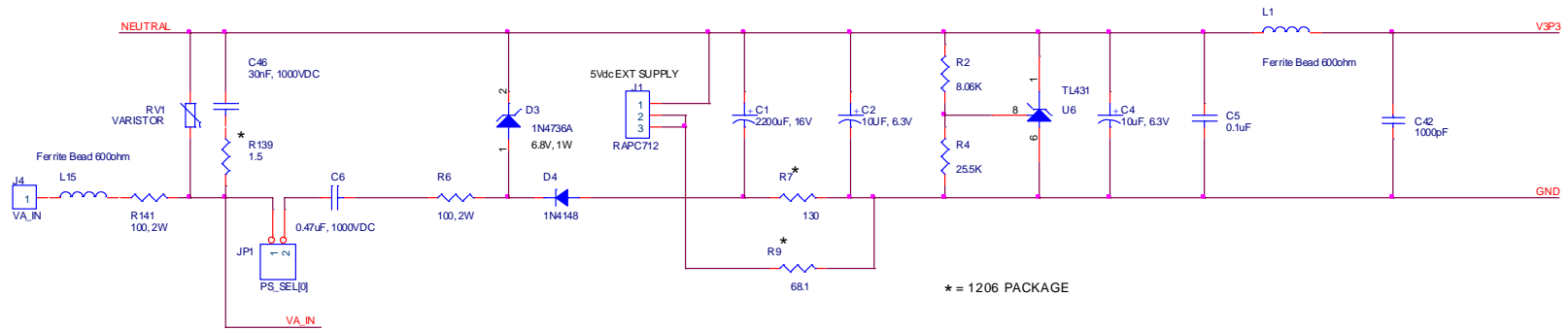

POWER SUPPLY SELECTION TABLE

SELECTION	PS_SEL[0] (JP1)
ON BOARD SUPPLY	IN
EXT 5Vdc SUPPLY THRU J1	OUT
EXT 5Vdc SUPPLY THRU DEBUG BOARD	OUT

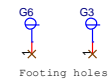
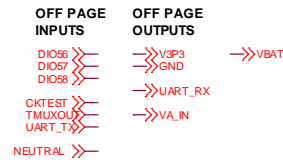
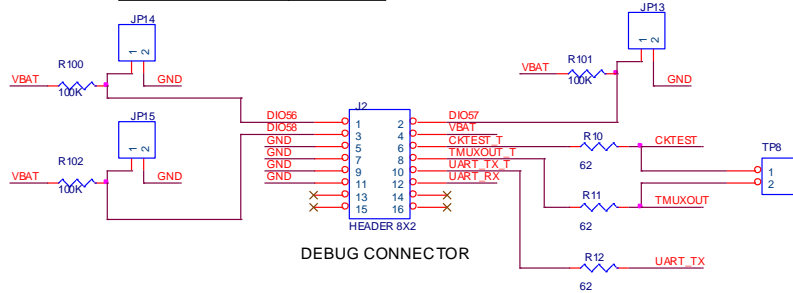

Title		
71M6533-4L-DB Neutral Current Capable		
Size	Document Number	Rev
B	D6533T1-4A3	3.0
Date:	Wednesday, March 26, 2008	Sheet 1 of 3

Figure 4-1: 71M6533-DB Demo Board: Electrical Schematic 1/3

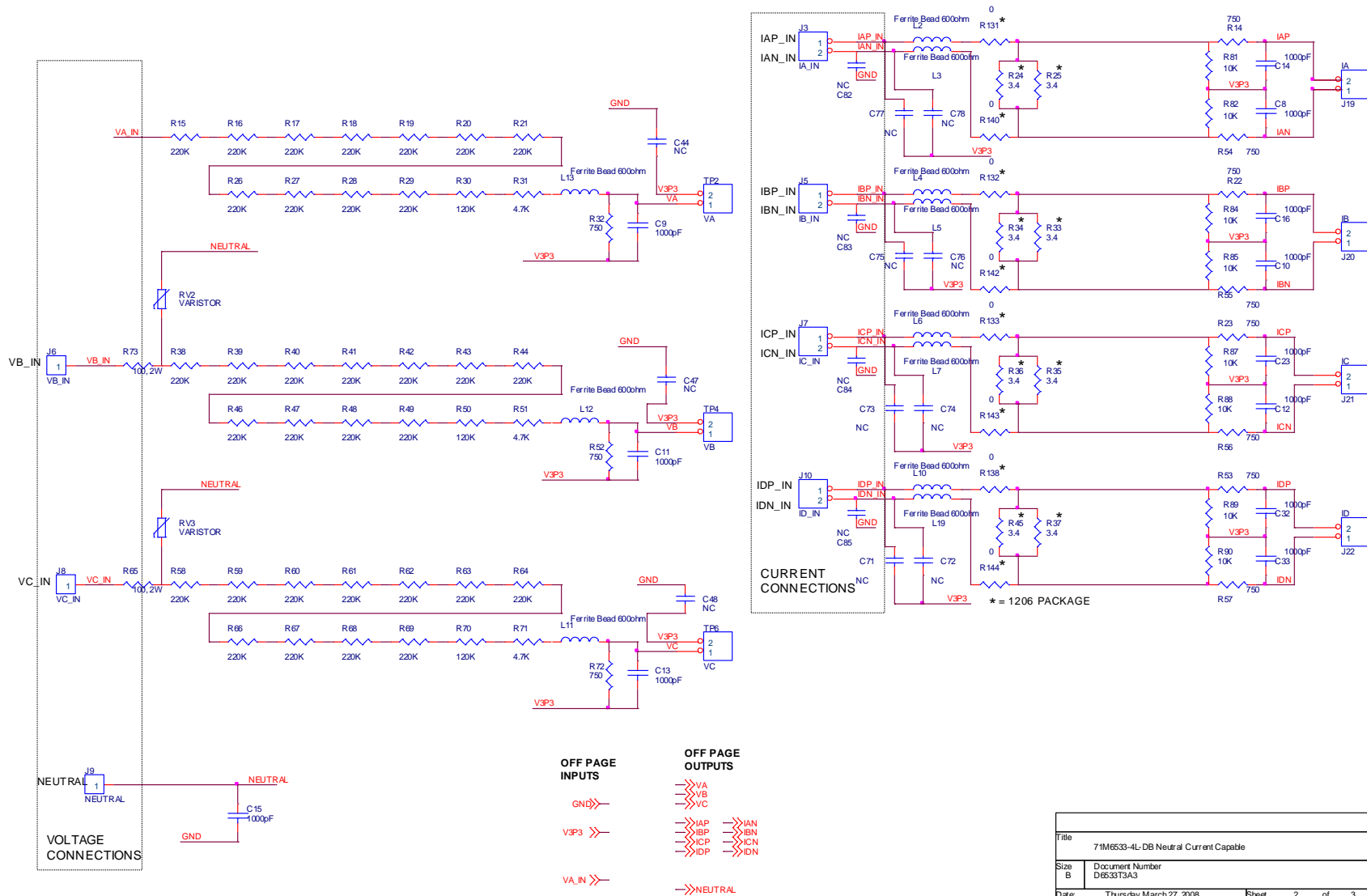

Figure 4-2: 71M6533-DB Demo Board: Electrical Schematic 2/3

Title		
71M6533-4L-DB Neutral Current Capable		
Size	Document Number	Rev
B	D65.3T3A3	3.0
Date	Thursday, March 27, 2008	Sheet 2 of 3

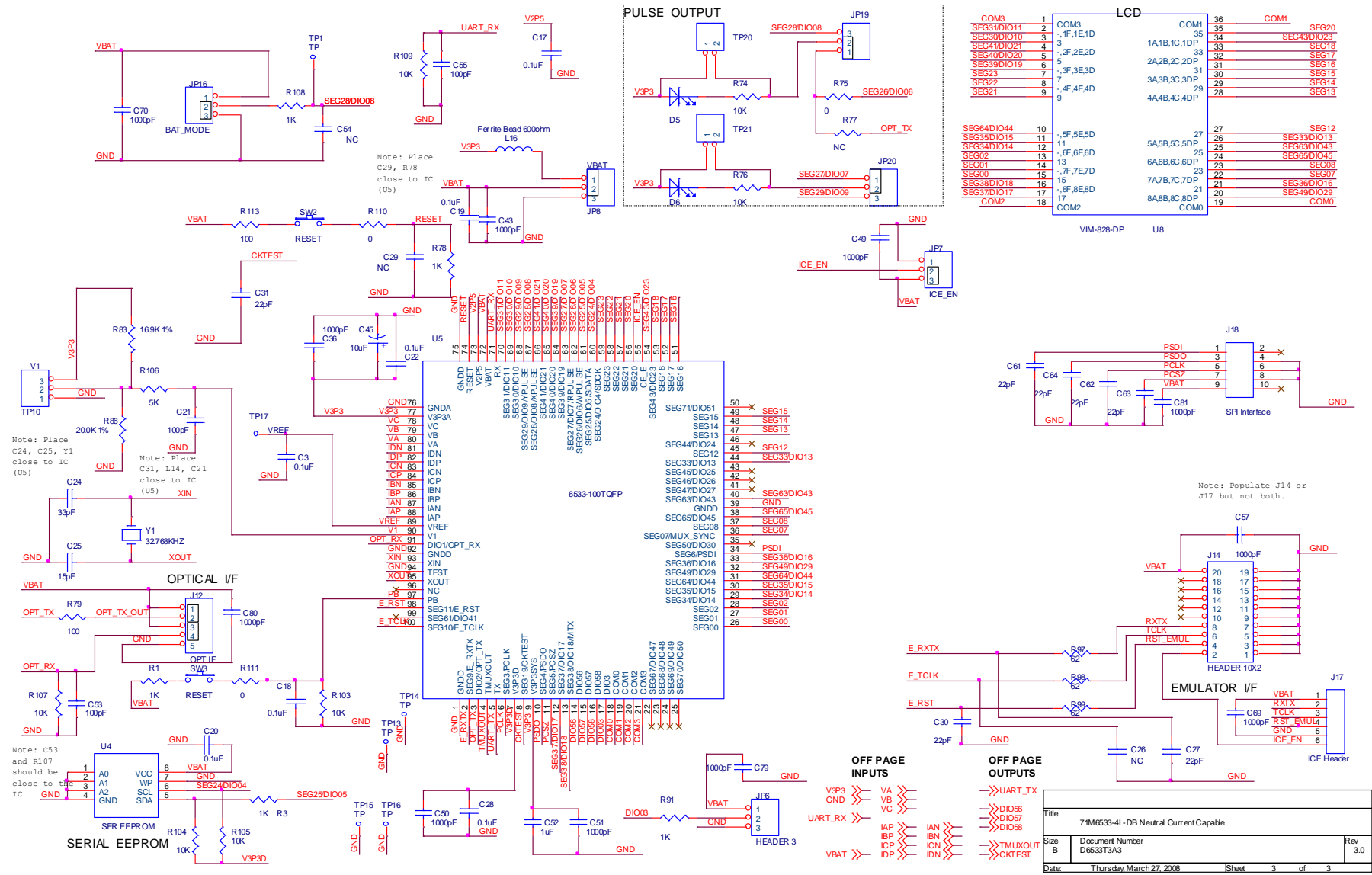

Figure 4-3: 71M6533-DB Demo Board: Electrical Schematic 3/3

## 4.2 71M6533-DB DEMO BOARD BILL OF MATERIAL

Item	Q	Reference	Part	PCB Footprint	Digi-Key/Mouser Part Number	Part Number	Manufacturer
1	1	C1	2200uF	radial	P5143-ND	ECA-1CM222	Panasonic
2	3	C2,C4,C45	10uF	RC1812	478-1672-1-ND	TAJB106K010R	AVX
3	8	C5,C17-C20,C22,C28,C29	0.1uF	RC0603	445-1314-1-ND	C1608X7R1H104K	TDK
4	1	C6	0.47uF		B1918-ND	2222 383 30474	Vishay
5	29	C8-C13,C15,C23,C33-C44	1000pF	RC0603	445-1298-1-ND	C1608X7R2A102K	TDK
		C47-C51, C56-C59					
6	3	C21,C32,C54	NC	RC0603			
7	1	C24	33pF	RC0603	445-1275-1-ND	C1608C0G1H330J	TDK
8	1	C25	7pF	RC0603	490-3564-1-ND	GQM1885C1H7R0CB01D	Murata
9	13	C26,C27,C31,C60-C68	22pF	RC0603	445-1273-1-ND	C1608C0G1H220J	TDK
10	1	C46	0.03uF	axial	75-125LS30-R	125LS30-R	Vishay
11	1	C52	1uF	RC0603	PCC2224CT-ND	ECJ-1V1B1C105K	Panasonic
12	2	C53,C55	100pF	RC0603	445-1281-1-ND	C1608C0G1H101J	TDK
13	1	D1	UCLAMP3301D	SOD-323	--	UCLAMP3301D.TCT	SEMTECH
14	1	D3	6.8V ZENER	D041	1N4736ADICT-ND	1N4736A-T	DIODES
15	1	D4	Switching Diode	D035	1N4148DICT-ND	1N4148-T	DIODES
16	2	D5,D6	LED	radial	404-1104-ND	H-3000L	Stanley
17	1	D8	NC	SOD-323			
18	1	J1	DC jack (2.5mm)	RAPC712	502-RAPC712X	RAPC712X	Switchcraft
19	1	J2	HEADER 8X2	8X2PIN	S2011E-36-ND	PZC36DAAN	Sullins
20	4	J3,J5,J7,J16	HEADER 2	2X1PIN	S1011E-36-ND	PZC36SAAN	Sullins
21	4	J4,J6,J8,J9	Spade Terminal		A24747CT-ND	62395-1	AMP
22	1	J10	DUAL ROW 12X2 PIN MALE	12X2PIN	929665-09-12-ND		3M
23	1	J11	DUAL ROW 12X2 PIN FEMALE	12X2PIN	S7115-ND	PPPC122LFBN-RC	Sullins
24	1	J12	HEADER 5	5X1PIN	S1011E-36-ND	PZC36SAAN	Sullins
25	1	J13	HEADER 4	4X1PIN	S1011E-36-ND	PZC36SAAN	Sullins
26	1	J14	10X2 CONNECTOR, 0.05"		571-5-104068-1	5-104068-1	AMP
27	1	J17	HEADER 6	6X1PIN	S1011E-36-ND	PZC36SAAN	Sullins
28	1	J18	HEADER 5X2	5X2PIN	S2011E-36-ND	PZC36DAAN	Sullins
29	6	JP1,JP13,JP14,JP15,JP17,JP18	HEADER 2	2X1PIN	S1011E-36-ND	PZC36SAAN	Sullins
30	5	JP6,JP7,JP8,JP16,JP19,JP20	HEADER 3	3X1PIN	S1011E-36-ND	PZC36SAAN	Sullins
31	1	JP12	HEADER 9	9X1PIN	S1011E-36-ND	PZC36SAAN	Sullins
32	17	L1-L9,L11-L18	Ferrite bead, 600 Ohm	RC0805	445-1556-1-ND	MMZ2012S601A	TDK
33	3	RV1,RV2,RV3	VARISTOR	radial	594-2381-594-55116	238159455116	Vishay
34	1	R2	8.06K, 1%	RC0805	311-8.06KCRCT-ND	RC0805FR-078060KL	Yageo
35	1	R4	25.5K, 1%	RC0805	311-25.5KCRCT-ND	RC08052FR-072552L	Yageo
36	4	R6,R65,R73,R141	100, 2W	axial	100W-2-ND	RSF200JB-100R	Yageo
37	1	R7	130, 1%	RC1206	311-130FRCT-ND	RC1206FR-071300L	Yageo
38	1	R9	68, 1%	RC1206	311-68.0FRCT-ND	RC1206FR-0768R0L	Yageo
39	11	R10,R11,R12,R90,R92,R93, R95,R96,R97,R98,R99	62	RC0805	P62ACT-ND	ERJ-6GEYJ620V	Panasonic
40	7	R14,R32,R34,R52,R53,R72, R135	750, 1%	RC0805	P750CCT-ND	ERJ-6ENF7500V	Panasonic
41	33	R15-R21,R26-R29,R38-R44, R46-R49,R58-R64,R66-R69	220K, 1%	RC0805	311-220KCRCT-ND	RC0805FR-07220KL	Yageo
42	8	R24,R25,R36,R37,R56,R57 R136,R137	3.4, 1%	RC1206	311-3.40FRCT-ND	RC1206FR-073R40L	Yageo
43	3	R30,R50,R70	120K, 1%	RC0805	311-120KCRCT-ND	RC0805FR-071203L	Yageo
44	3	R31,R51,R71	4.70K, 1%	RC0805	311-4.70KCRCT-ND	RC0805FR-074701L	Yageo
45	9	R74,R76,R80,R103,R104,R105, R106,R107	10K	RC0805	P10KACT-ND	ERJ-6GEYJ103V	Panasonic
46	2	R75,R94	0	RC0805	P0.0ACT-ND	ERJ-6GEY0R00V	Panasonic
47	1	R77	NC	RC0805			
48	4	R78,R91,R108,R111	1K	RC0805	P1.0KACT-ND	ERJ-6GEYJ102V	Panasonic
49	2	R79,R110	100	RC0805	P100ACT-ND	ERJ-6GEYJ101J	Panasonic
50	1	R83	16.9K, 1%	RC0805	P16.9KCCT-ND	ERJ-6ENF1692V	Panasonic
51	1	R86	20.0K, 1%	RC0805	P20.0KCCT-ND	ERJ-6ENF2002V	Panasonic
52	3	R100,R101,R102	100K	RC0805	P100KACT-ND	ERJ-6GEYJ104V	Panasonic
53	4	R131,R132,R133,R134	0	RC1206	P0.0ECT-ND	ERJ-8GEY0R00V	Panasonic
54	1	R139	1.5	RC1206	P1.5ECT-ND	ERJ-8GEYJ1R5V	Panasonic
55	1	SW2,SW3	SWITCH		P8051SCT-ND	EVQ-PJX05M	Panasonic
56	10	TP1-TP8,TP20,TP21	TP	2X1PIN	S1011E-36-ND	PZC36SAAN	Sullins
57	1	TP10	TP	3X1PIN	S1011E-36-ND	PZC36SAAN	Sullins
58	4	TP13-TP16	Test Point		5011K-ND	5011	Keystone 1)
60	3	U1,U2,U3,U7	BAV99DW	SOT363	BAV99DW-FDICT-ND	BAV99DW-7-F	DIODES
61	1	U4	SER EEPROM	SO8	AT24C256BN-10SU-1.8-ND	AT24C256BN-10SU-1.8	ATMEL
62	1	U5	71M6533	100TQFP	--	71M6533-IGT	TERIDIAN
63	1	at U5	100TQFP Socket	100TQFP	--	IC149-100-154B51	Yamaichi
64	1	U6	REGULATOR, 1%	SO8	296-1288-1-ND	TL431AIDR	Texas Instruments
65	1	Y1	32.768kHz		XC1195CT-ND	ECS-327-12.5-17X-TR	ECS
66	1	U8	LCD, 3.3V		153-1110-ND	VIM-828-DP5.7-6-RC-S-LV	VARITRONIX 2)

Table 4-1: 71M6533-DB Demo Board: Bill of Material

### 4.3 71M6533-DB DEMO BOARD PCB LAYOUT

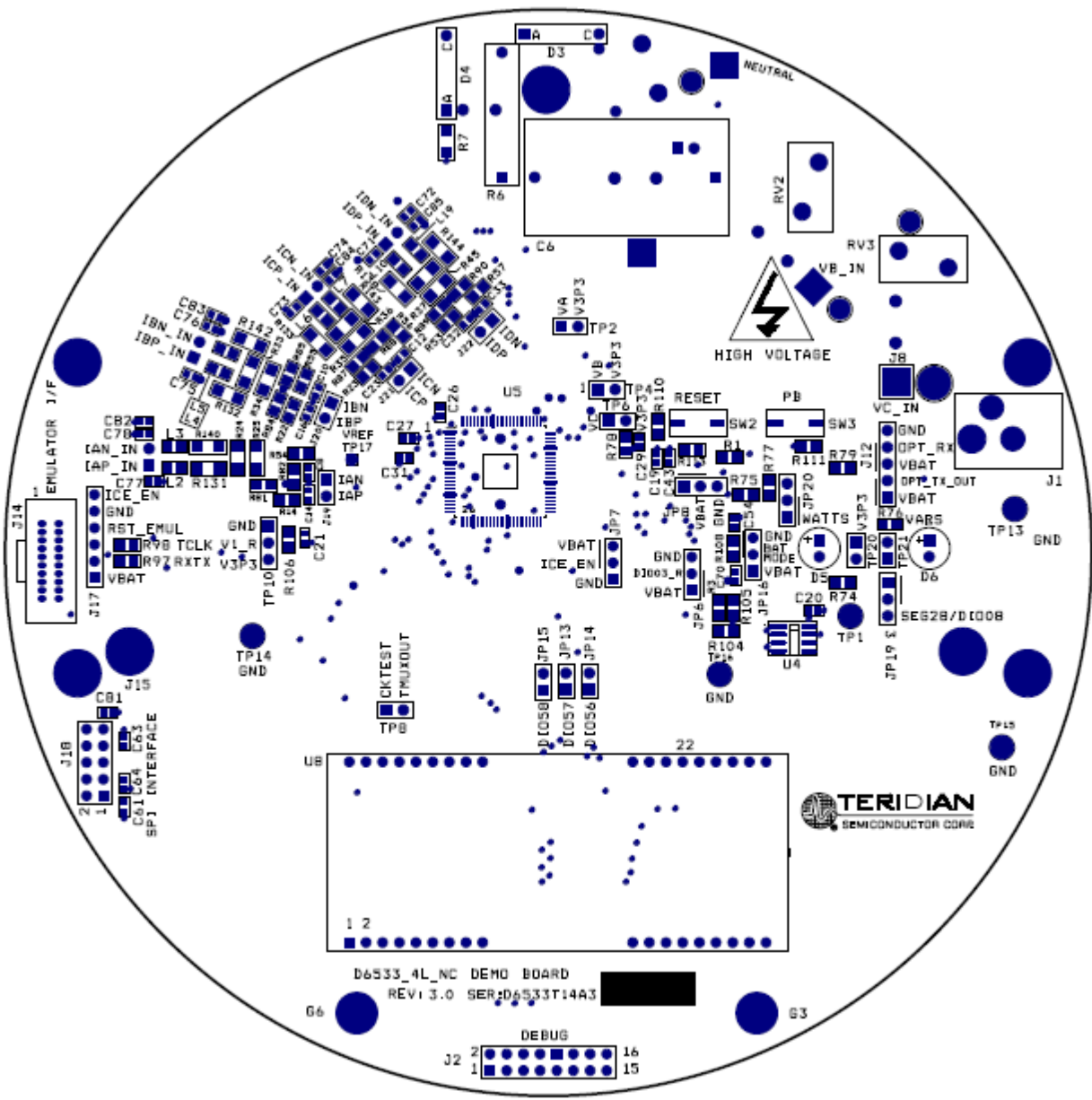

Figure 4-4: 71M6533-DB Demo Board: Top View

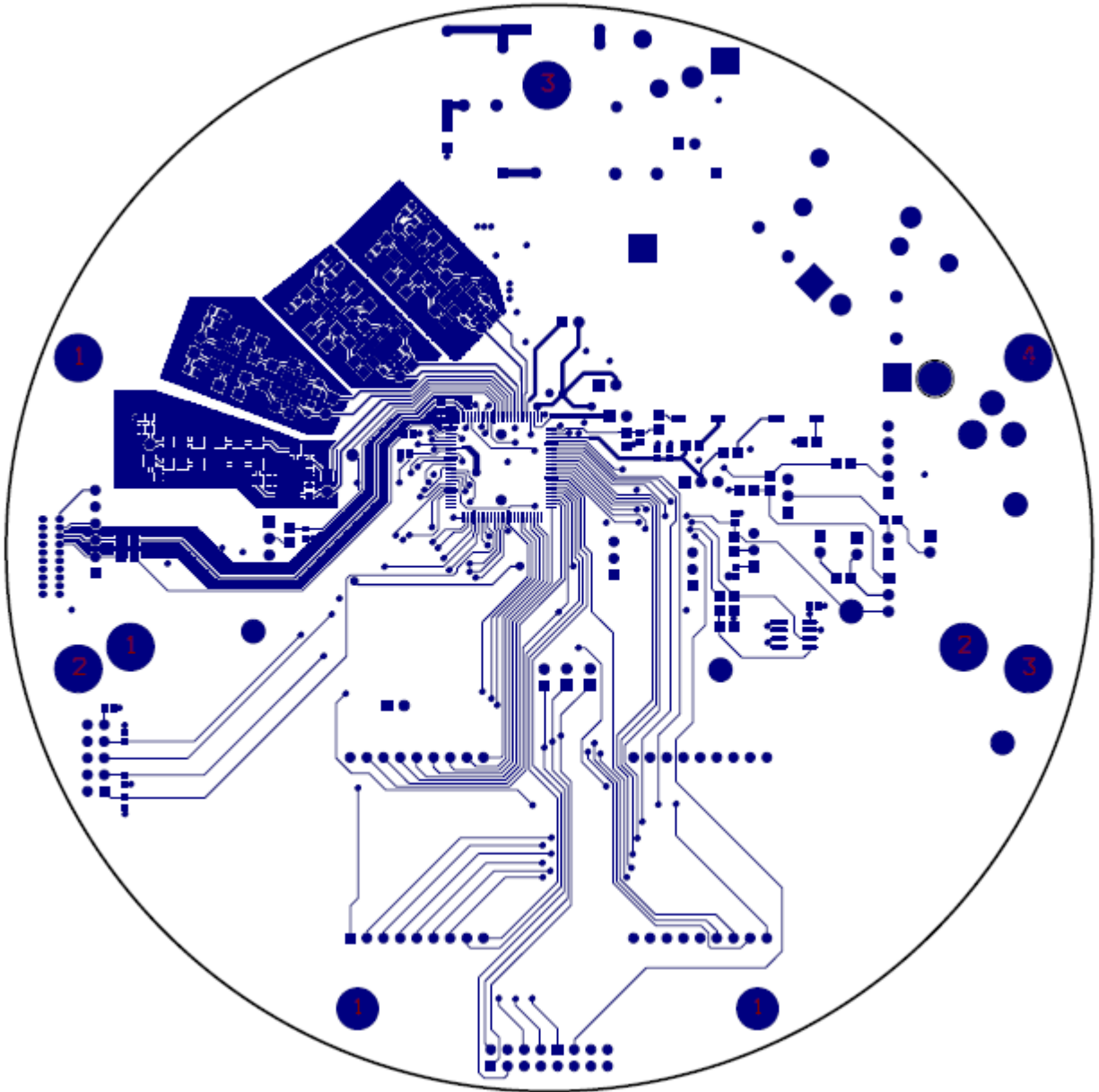
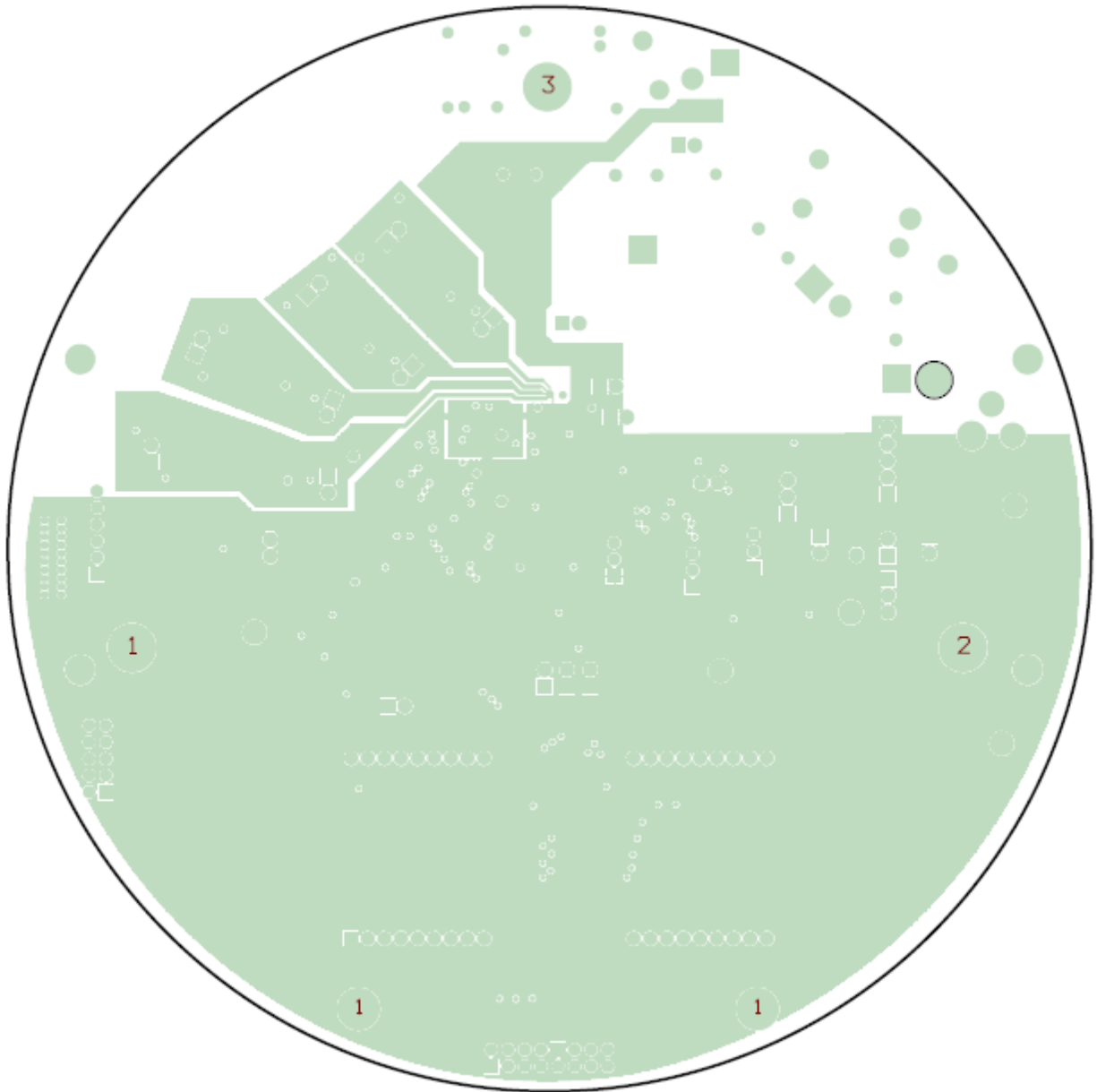

Figure 4-5: 71M6533-DB Demo Board: Top Copper



**Figure 4-6: 71M6533-DB Demo Board: Middle Layer 1 (Ground Plane)**

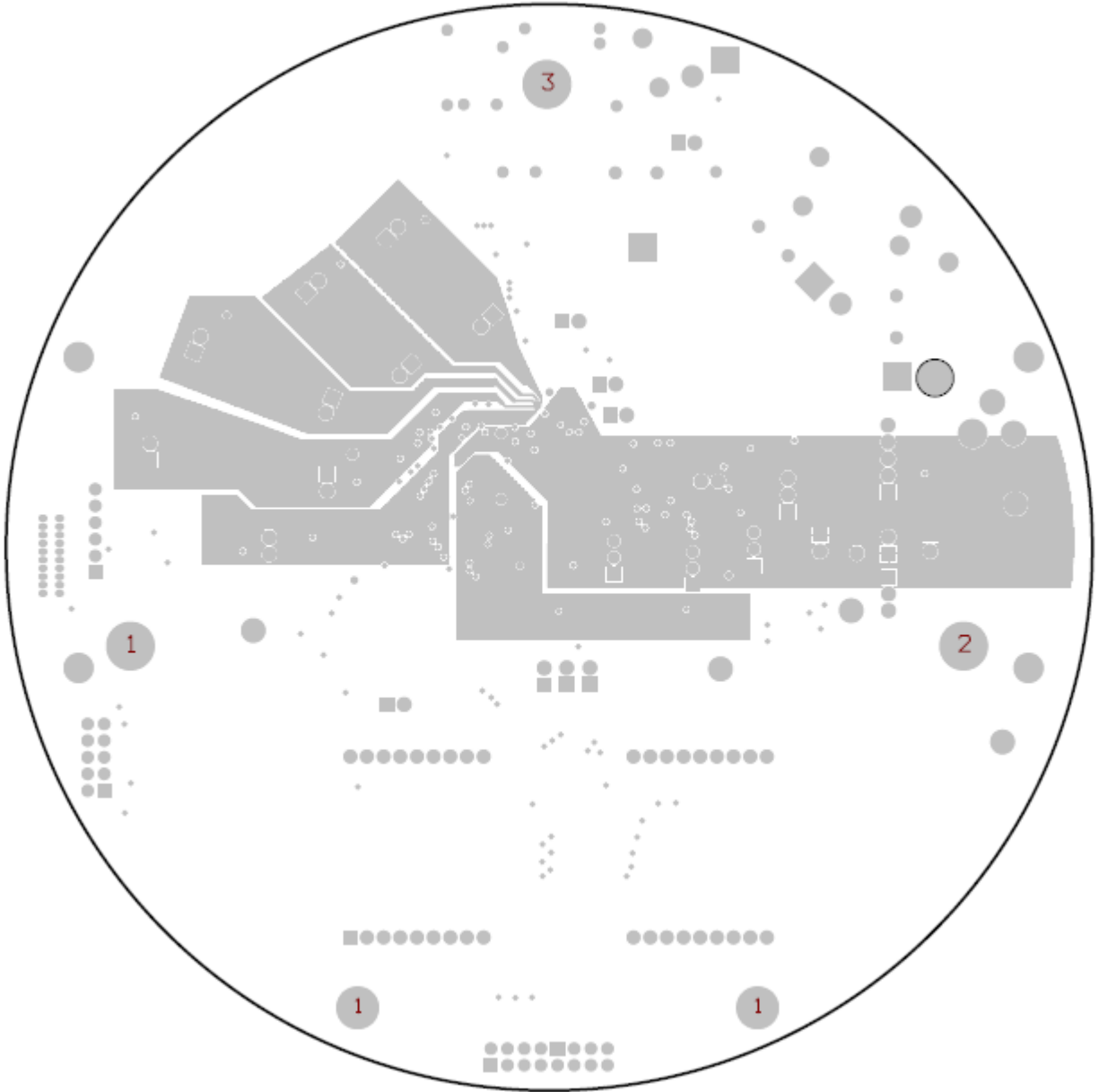

Figure 4-7: 71M6533-DB Demo Board: Middle Layer 2 (Supply Plane)

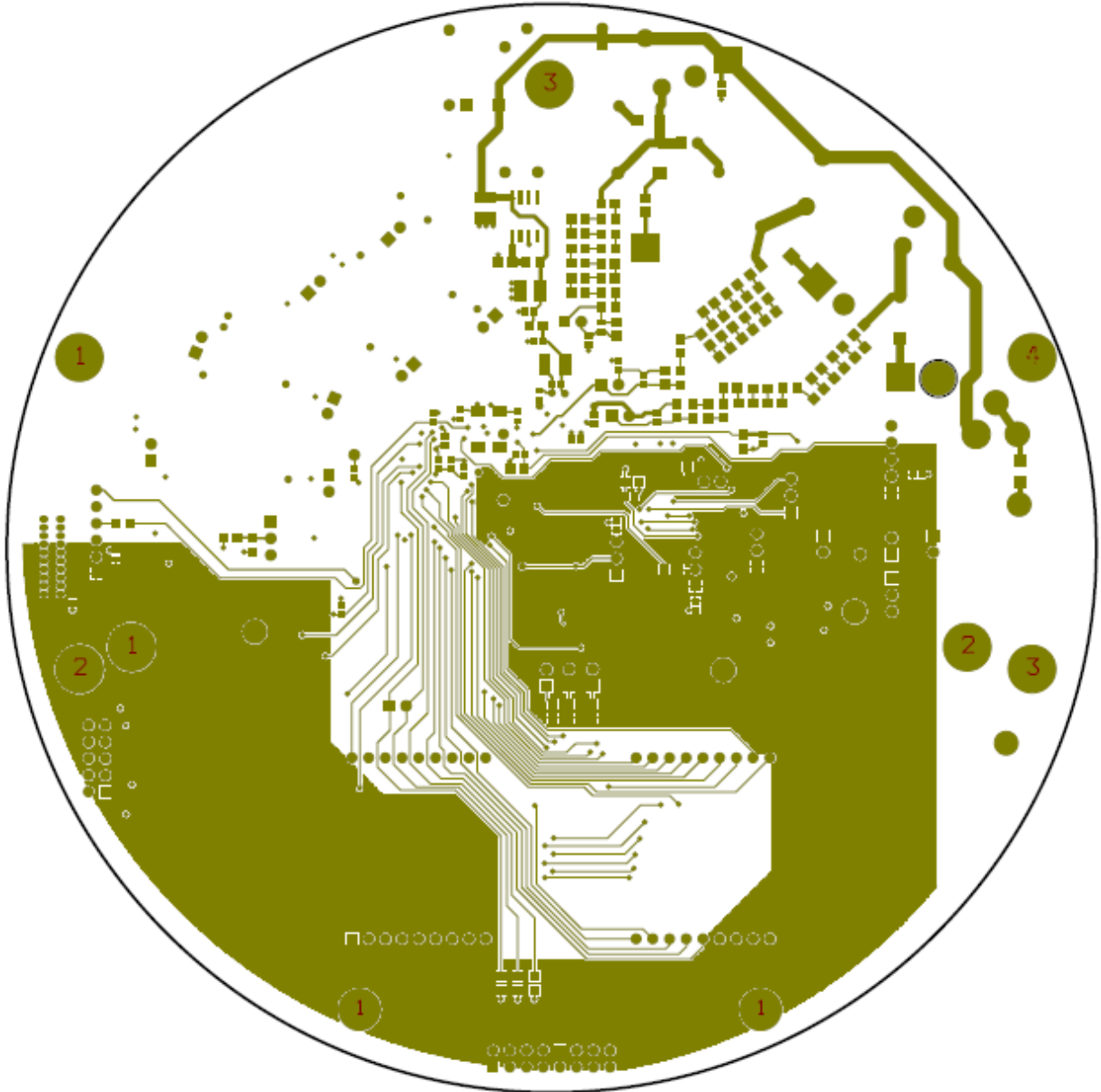

Figure 4-8: 71M6533-DB Demo Board: Bottom Copper



## 4.4 71M6533 PIN-OUT INFORMATION

### Power/Ground/NC Pins:

Name	Type	Pin #	Description
GNDA	P	76	Analog ground: This pin should be connected directly to the ground plane.
GNDD	P	1, 39, 75, 92	Digital ground: This pin should be connected directly to the ground plane.
V3P3A	P	77	Analog power supply: A 3.3V power supply should be connected to this pin. V3P3A must be the same voltage as V3P3SYS.
V3P3SYS	P	9	System 3.3V supply. This pin should be connected to a 3.3V power supply.
V3P3D	P	7	Auxiliary voltage output of the chip, controlled by the internal 3.3V selection switch. In mission mode, this pin is internally connected to V3P3SYS. In BROWNOUT mode, it is internally connected to VBAT. This pin is floating in LCD and sleep mode.
VBAT	P	72	Battery backup power and oscillator supply. A battery or super-capacitor is to be connected between VBAT and GNDD. <b><u>If no battery is used, connect VBAT to V3P3SYS.</u></b>
V2P5	O	73	Output of the internal 2.5V regulator. A 0.1 $\mu$ F capacitor to GNDA should be connected to this pin.

Table 4-2: 71M6533/71M6533H Pin Description Table 1/3

### Analog Pins:

Name	Type	Pin #	Description
IAP/IAN, IBP/IBN, ICP/ICN, IDP/IDN	I	88,87, 86,85, 84,83, 82,81	Differential Line Current Sense Inputs: These pins are voltage inputs to the internal A/D converter. Typically, they are connected to the outputs of current sensors. <b>Unused pins must be tied to V3P3A.</b> IDP/IDN are additional Line Current Sense Input pins.
VA, VB, VC	I	80, 79, 78	Line Voltage Sense Inputs: These pins are voltage inputs to the internal A/D converter. Typically, they are connected to the outputs of resistor dividers. <b>Unused pins must be tied to V3P3A.</b>
V1	I	90	Comparator Input: This pin is a voltage input to the internal comparator. The voltage applied to the pin is compared to an internal BIAS voltage (1.6V). If the input voltage is above the reference, the comparator output will be high (1). If the comparator output is low, a voltage fault will occur. A series 5k $\Omega$ resistor should be connected from V1 to the resistor divider.
VREF	O	89	Voltage Reference for the ADC. This pin should be left unconnected (floating).
XIN XOUT	I	93, 95	Crystal Inputs: A 32kHz crystal should be connected across these pins. Typically, a 33pF capacitor is also connected from XIN to GNDA and a 15pF capacitor is connected from XOUT to GNDA. It is important to minimize the capacitance between these pins. See the crystal manufacturer datasheet for details.

Table 4-3: 71M6533/71M6533H Pin Description Table 2/3

**Digital Pins:**

Name	Type	Pin #	Description
COM3, COM2, COM1, COM0	O	21, 20, 19, 18	LCD Common Outputs: These 4 pins provide the select signals for the LCD display.
SEG0...SEG2, SEG12, SEG13...SEG15, SEG16...SEG18, SEG20...SEG23, DIO3, DIO56...DIO58	O	26- 28, 45 47- 49, 51-53 56- 59, 17, 14-16	Dedicated LCD Segment Outputs.
SEG24/DIO4 ... SEG31/DIO11, SEG33/DIO13 ... SEG41/DIO21, SEG43/DIO23 ... SEG47/DIO27, SEG49/DIO29 ... SEG50/DIO30, SEG61/DIO41, SEG63/DIO43 ... SEG65/DIO45, SEG67/DIO47 ... SEG71/DIO51	I/O		Multi-use pins, configurable as either LCD SEG driver or DIO. (DIO4 = SCK, DIO5 = SDA when configured as EEPROM interface, WPULSE = DIO6, VARPULSE = DIO7, DIO8 = XPULSE, DIO9 = YPULSE when configured as pulse outputs). <b>Unused pins must be configured as outputs or tied to V3P3D or GNDD.</b>
SEG3/PCLK SEG4/PSDO SEG5/PCSZ SEG6/PSDI	I/O	6, 10, 11, 34	Multi-use pins, configurable as either LCD segment driver or SPI PORT.
E_RXTX/SEG9	I/O	2, 98	Multi-use pins, configurable as either emulator port pins (when ICE_E pulled high) or LCD SEG drivers (when ICE_E tied to GND).
E_RST/SEG11			
E_TCLK/SEG10	O	100	
ICE_E	I	55	ICE enable. When low, E_RST, E_TCLK, and E_RXTX become LCD segment pins. For production units, this pin should be pulled to GND to disable the emulator port.
CKTEST/SEG19, MUXSYNC/SEG7	O	8, 36	Multi-use pins, configurable as either Clock PLL/multiplexer control outputs or LCD segment drivers. CKTEST can be enabled and disabled by <i>CKOUT_EN</i> .
TMUXOUT	O	4	Digital output test multiplexer. Controlled by <i>DMUX[3:0]</i> .

Name	Type	Pin #	Description
OPT_RX/DIO1	I/O	91	Multi-use pin, configurable as either Optical Receive Input or general DIO. When configured as OPT_RX, this pin is a regular UART RX pin. <b>If this pin is unused it must be configured as an output or tied to V3P3D or GNDD.</b>
OPT_TX/DIO2	I/O	3	Multi-use pin, configurable as either Optical LED Transmit Output. When configured as OPT_TX, this pin is capable of directly driving an LED for transmitting data in an IR serial interface.
RESET	I	74	Chip reset: This input pin is used to reset the chip into a known state. For normal operation, this pin is pulled low. To reset the chip, this pin should be pulled high. This pin has an internal 30 $\mu$ A (nominal) current source pull-down. No external reset circuitry is necessary.
RX	I	71	UART input. <b>If this pin is unused it must be configured as an output or tied to V3P3D or GNDD.</b>
TX	O	5	UART output.
TEST	I	94	Enables Production Test. <b>This pin must be grounded in normal operation.</b>
PB	I	97	Push button input. Should be at GND when not active. A rising edge sets the <i>IE_PB</i> flag. It also causes the part to wake up if it is in SLEEP or LCD mode. PB does not have an internal pull-up or pull-down resistor.

Table 4-4: 71M6533/71M6533H Pin Description Table 3/3

Pin types: P = Power, O = Output, I = Input, I/O = Input/Output

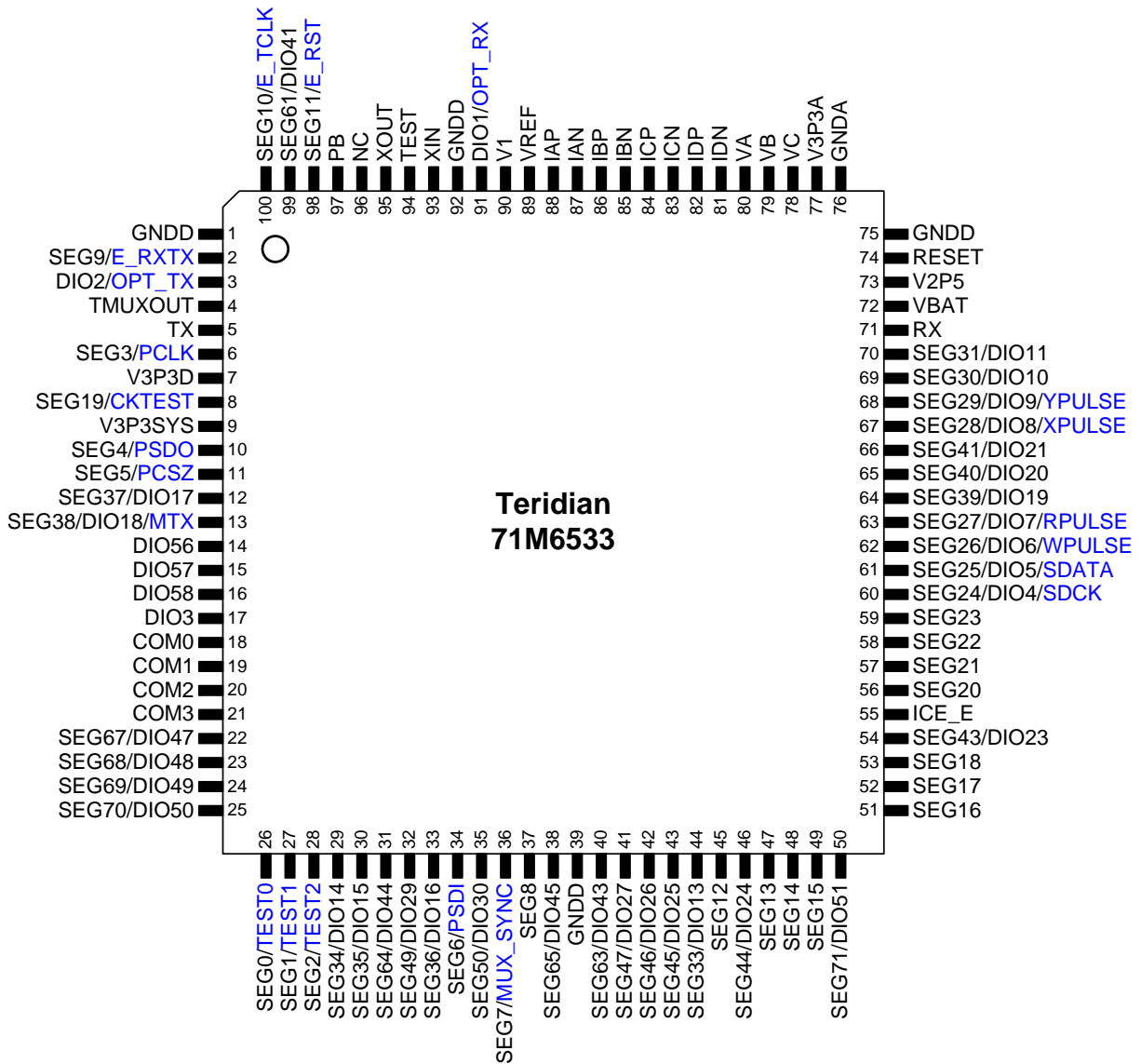

Figure 4-10: 71M6533/71M6533H epLQFP100: Pin Out (top view)



## 5 REVISION HISTORY

Revision	Date	Description
1.0	1-30-2008	Initial release
1.1	2-5-2008	Updated copyright date in footers. Added text stating that no jumper should be across VBAT and OPT_TX_OUT (J12) and updated Figure 3-1. Updated pin description tables. Corrected Figure 2-9, added load line graph for differential mode.
1.2	2-25-2008	Updated to include Demo Board revision DB6533T14A3 and new pin-out arrangement of 71M6533. Updated Calibration Procedures section.
2.0	6-13-2011	Replaced Teridian logo with Maxim logo in headers. Removed list of Application Notes from section 2.6. Added information on the USB-to-Serial Adapter.
2.1	9-26-2011	Corrected calculation and address for WRATE on page 23. Intermediate revision (not published).
3	7-31-2012	Removed references to TGP1 Gang Programmer (no longer supported) and to Debug Board (replaced by USB-Serial Adapter). Changed naming conventions (71M6533-DB). Corrected name for TFP2. Removed references to 71M6533H (the 71M6533-DB is shipped with the 71M6533). Updated Figure 2-9. Added comments on the use of ferrites and reference to Application Note AN-5292 (2.4.7). Added Battery-Mode Commands in section 1.8.1.

## Looking for pricing, stock, or lifecycle information?

Click below to explore more details on WIN SOURCE:

 [View 71M6533H-IGT/F on WIN SOURCE](#)

 [Maxim Integrated](#) Information

## Optimize Your Supply Chain with WIN SOURCE Solutions

-  Global Sourcing Solution
-  Obsolete Management
-  Cost Control Management
-  Shortage Management
-  Alternative Solution
-  Excess Inventory Management