



**THE DATASHEET OF
70T3589S133BC8**





HIGH-SPEED 2.5V 256/128/64K x 36 SYNCHRONOUS DUAL-PORT STATIC RAM WITH 3.3V OR 2.5V INTERFACE

IDT70T3519/99/89S

LEAD FINISH (SnPb) ARE IN EOL PROCESS - LAST TIME BUY EXPIRES JUNE 15, 2018

Features:

- ◆ True Dual-Port memory cells which allow simultaneous access of the same memory location
- ◆ High-speed data access
 - Commercial: 3.4 (200MHz)/3.6ns (166MHz)/4.2ns (133MHz)(max.)
 - Industrial: 3.6ns (166MHz)/4.2ns (133MHz) (max.)
- ◆ Selectable Pipelined or Flow-Through output mode
- ◆ Counter enable and repeat features
- ◆ Dual chip enables allow for depth expansion without additional logic
- ◆ Full synchronous operation on both ports
 - 5ns cycle time, 200MHz operation (14Gbps bandwidth)
 - Fast 3.4ns clock to data out
 - 1.5ns setup to clock and 0.5ns hold on all control, data, and address inputs @ 200MHz
 - Data input, address, byte enable and control registers
 - Self-timed write allows fast cycle time
- ◆ Interrupt and Collision Detection Flags
- ◆ Separate byte controls for multiplexed bus and bus matching compatibility
- ◆ Dual Cycle Deselect (DCD) for Pipelined Output Mode
- ◆ 2.5V (±100mV) power supply for core
- ◆ LVTTTL compatible, selectable 3.3V (±150mV) or 2.5V (±100mV) power supply for I/Os and control signals on each port
- ◆ Industrial temperature range (-40°C to +85°C) is available at 166MHz and 133MHz
- ◆ Available in a 256-pin Ball Grid Array (BGA), a 208-pin Plastic Quad Flatpack (PQFP) and 208-pin fine pitch Ball Grid Array (fpBGA)
- ◆ Supports JTAG features compliant with IEEE 1149.1
- ◆ Due to limited pin count JTAG is not supported on the 208-pin PQFP package
- ◆ Green parts available, see ordering information

Functional Block Diagram

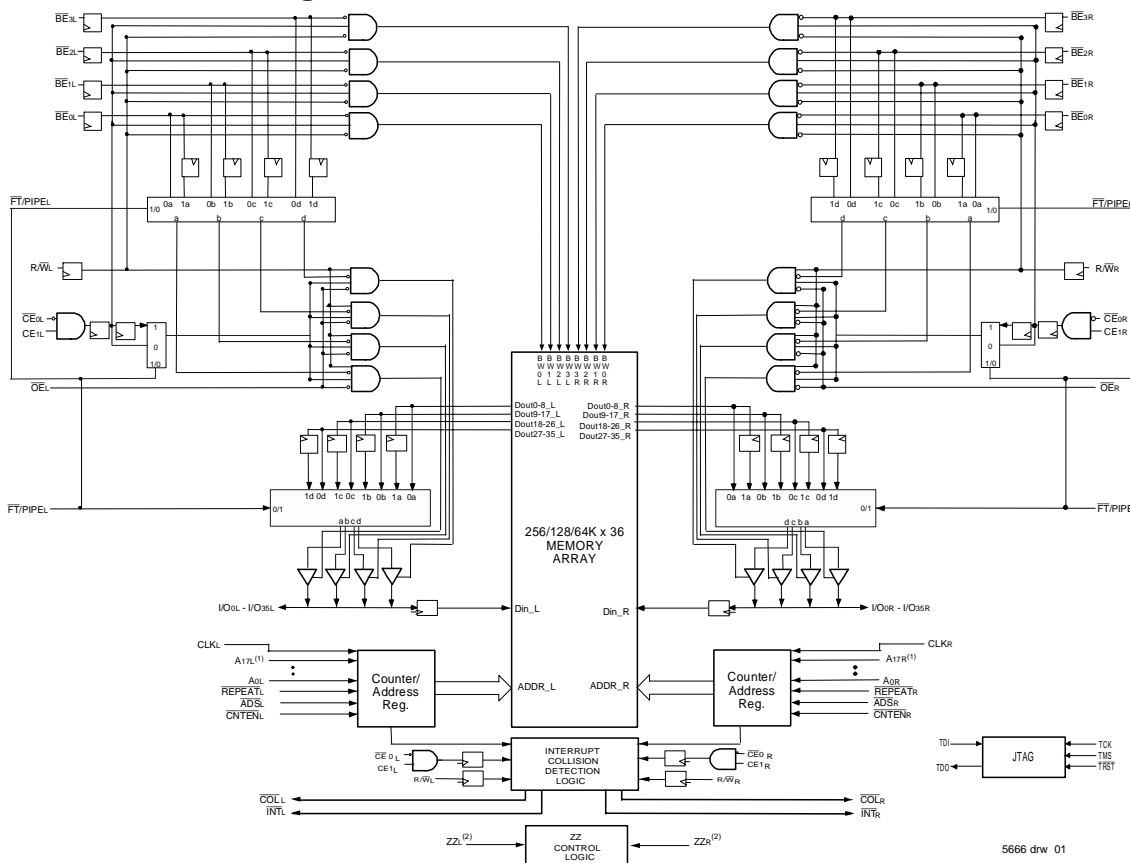

NOTES:

1. Address A17 is a NC for the IDT70T3599. Also, Addresses A17 and A16 are NC's for the IDT70T3589.
2. The sleep mode pin shuts off all dynamic inputs, except JTAG inputs, when asserted. All static inputs, i.e., PL/FTx and OPTx and the sleep mode pins themselves (ZZx) are not affected during sleep mode.

JUNE 2018

Description:

The IDT70T3519/99/89 is a high-speed 256/128/64K x 36 bit synchronous Dual-Port RAM. The memory array utilizes Dual-Port memory cells to allow simultaneous access of any address from both ports. Registers on control, data, and address inputs provide minimal setup and hold times. The timing latitude provided by this approach allows systems to be designed with very short cycle times. With an input data register, the IDT70T3519/99/89 has been optimized for applications having unidirec-

tional or bidirectional data flow in bursts. An automatic power down feature, controlled by \overline{CE}_0 and CE_1 , permits the on-chip circuitry of each port to enter a very low standby power mode.

The 70T3519/99/89 can support an operating voltage of either 3.3V or 2.5V on one or both ports, controllable by the OPT pins. The power supply for the core of the device (V_{DD}) is at 2.5V.

Pin Configuration (3,4,5,6)

70T3519/99/89BC
BC256⁽⁷⁾256-Pin BGA
Top View⁽⁸⁾

06/19/02

A1 NC	A2 TDI	A3 NC	A4 A17L ⁽¹⁾	A5 A14L	A6 A11L	A7 A8L	A8 \overline{BE}_{2L}	A9 CE1L	A10 \overline{OE}_L	A11 CNTENL	A12 A5L	A13 A2L	A14 A0L	A15 NC	A16 NC
B1 I/O18L	B2 NC	B3 TDO	B4 NC	B5 A15L	B6 A12L	B7 A9L	B8 \overline{BE}_{3L}	B9 \overline{CE}_{0L}	B10 R/WL	B11 REPEATL	B12 A4L	B13 A1L	B14 VDD	B15 I/O17L	B16 NC
C1 I/O18R	C2 I/O19L	C3 VSS	C4 A16L ⁽²⁾	C5 A13L	C6 A10L	C7 A7L	C8 \overline{BE}_{1L}	C9 \overline{BE}_{0L}	C10 CLKL	C11 \overline{ADS}_L	C12 A6L	C13 A3L	C14 OPTL	C15 I/O17R	C16 I/O16L
D1 I/O20R	D2 I/O19R	D3 I/O20L	D4 PIPE/FTL	D5 VDDQL	D6 VDDQL	D7 VDDQR	D8 VDDQR	D9 VDDQL	D10 VDDQL	D11 VDDQR	D12 VDDQR	D13 VDD	D14 I/O15R	D15 I/O15L	D16 I/O16R
E1 I/O21R	E2 I/O21L	E3 I/O22L	E4 VDDQL	E5 VDD	E6 VDD	E7 \overline{INT}_L	E8 VSS	E9 VSS	E10 VSS	E11 VDD	E12 VDD	E13 VDDQR	E14 I/O13L	E15 I/O14L	E16 I/O14R
F1 I/O23L	F2 I/O22R	F3 I/O23R	F4 VDDQL	F5 VDD	F6 NC	F7 \overline{COL}_L	F8 VSS	F9 VSS	F10 VSS	F11 VSS	F12 VDD	F13 VDDQR	F14 I/O12R	F15 I/O13R	F16 I/O12L
G1 I/O24R	G2 I/O24L	G3 I/O25L	G4 VDDQR	G5 VSS	G6 VSS	G7 VSS	G8 VSS	G9 VSS	G10 VSS	G11 VSS	G12 VSS	G13 VDDQL	G14 I/O10L	G15 I/O11L	G16 I/O11R
H1 I/O26L	H2 I/O25R	H3 I/O26R	H4 VDDQR	H5 VSS	H6 VSS	H7 VSS	H8 VSS	H9 VSS	H10 VSS	H11 VSS	H12 VSS	H13 VDDQL	H14 I/O9R	H15 I/O9L	H16 I/O10R
J1 I/O27L	J2 I/O28R	J3 I/O27R	J4 VDDQL	J5 ZZR	J6 VSS	J7 VSS	J8 VSS	J9 VSS	J10 VSS	J11 VSS	J12 ZZL	J13 VDDQR	J14 I/O8R	J15 I/O7R	J16 I/O8L
K1 I/O29R	K2 I/O29L	K3 I/O28L	K4 VDDQL	K5 VSS	K6 VSS	K7 VSS	K8 VSS	K9 VSS	K10 VSS	K11 VSS	K12 VSS	K13 VDDQR	K14 I/O6R	K15 I/O6L	K16 I/O7L
L1 I/O30L	L2 I/O31R	L3 I/O30R	L4 VDDQR	L5 VDD	L6 NC	L7 \overline{COL}_R	L8 VSS	L9 VSS	L10 VSS	L11 VSS	L12 VDD	L13 VDDQL	L14 I/O5L	L15 I/O4R	L16 I/O5R
M1 I/O32R	M2 I/O32L	M3 I/O31L	M4 VDDQR	M5 VDD	M6 VDD	M7 \overline{INTR}	M8 VSS	M9 VSS	M10 VSS	M11 VDD	M12 VDD	M13 VDDQL	M14 I/O3R	M15 I/O3L	M16 I/O4L
N1 I/O33L	N2 I/O34R	N3 I/O33R	N4 PIPE/FTR	N5 VDDQR	N6 VDDQR	N7 VDDQL	N8 VDDQL	N9 VDDQR	N10 VDDQR	N11 VDDQL	N12 VDDQL	N13 VDD	N14 I/O2L	N15 I/O1R	N16 I/O2R
P1 I/O35R	P2 I/O34L	P3 TMS	P4 A16R ⁽²⁾	P5 A13R	P6 A10R	P7 A7R	P8 \overline{BE}_{1R}	P9 \overline{BE}_{0R}	P10 CLKR	P11 \overline{ADS}_R	P12 A6R	P13 A3R	P14 I/O0L	P15 I/O0R	P16 I/O1L
R1 I/O35L	R2 NC	R3 TRST	R4 NC	R5 A15R	R6 A12R	R7 A9R	R8 \overline{BE}_{3R}	R9 \overline{CE}_{0R}	R10 R/WR	R11 REPEATR	R12 A4R	R13 A1R	R14 OPTR	R15 NC	R16 NC
T1 NC	T2 TCK	T3 NC	T4 A17R ⁽¹⁾	T5 A14R	T6 A11R	T7 A8R	T8 \overline{BE}_{2R}	T9 CE1R	T10 \overline{OE}_R	T11 CNTENR	T12 A5R	T13 A2R	T14 A0R	T15 NC	T16 NC

5666 drw 02d

NOTES:

1. Pin is a NC for IDT70T3599 and IDT70T3589.
2. Pin is a NC for IDT70T3589.
3. All VDD pins must be connected to 2.5V power supply.
4. All VDDQ pins must be connected to appropriate power supply: 3.3V if OPT pin for that port is set to VDD (2.5V), and 2.5V if OPT pin for that port is set to VSS (0V).
5. All VSS pins must be connected to ground supply.
6. Package body is approximately 17mm x 17mm x 1.4mm, with 1.0mm ball-pitch.
7. This package code is used to reference the package diagram.
8. This text does not indicate orientation of the actual part-marking.

Pin Configuration (3,4,5,6,9) (con't.)

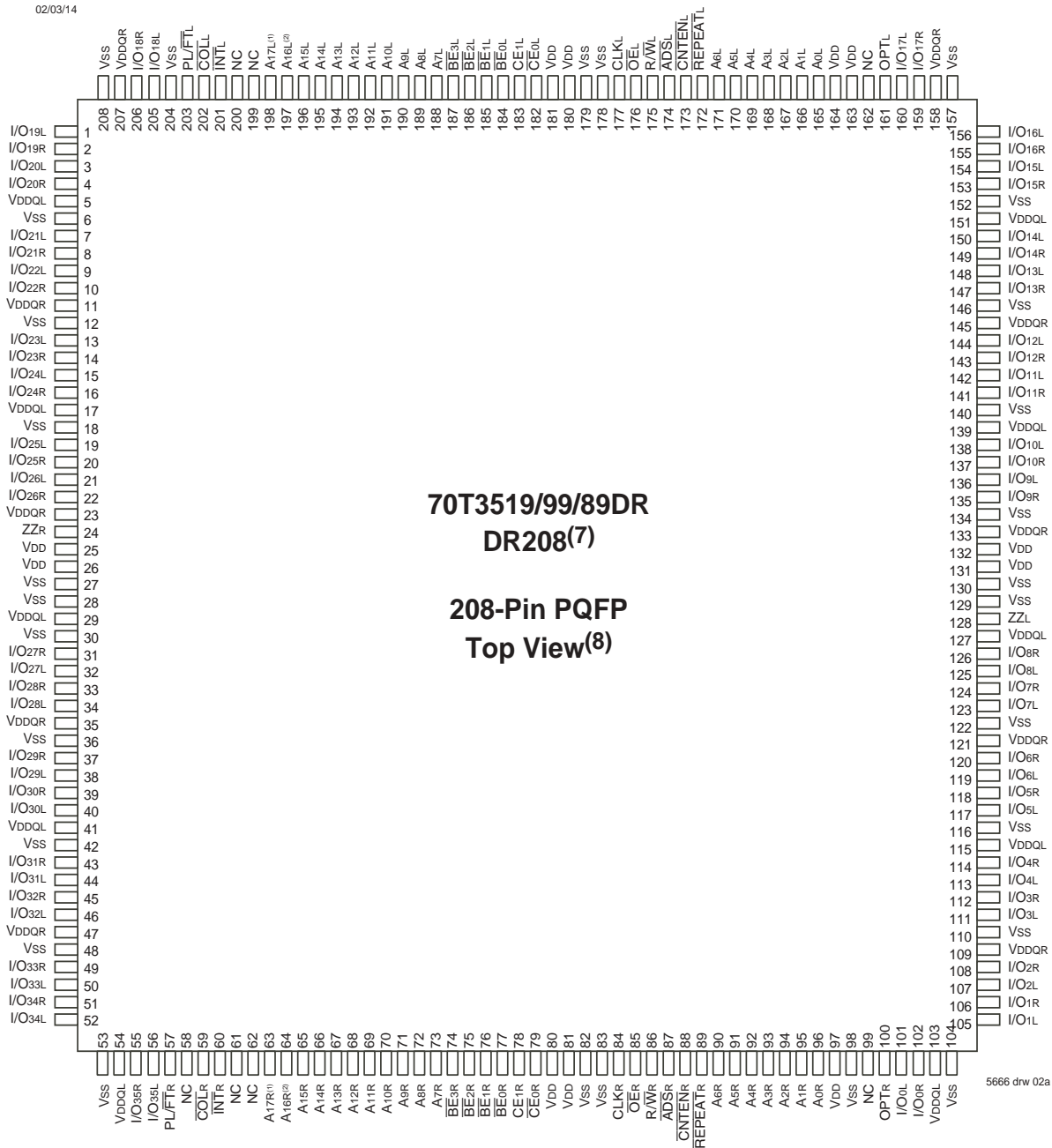

70T3519/99/89DR
DR208(7)
208-Pin PQFP
Top View⁽⁸⁾

NOTES:

1. Pin is a NC for IDT70T3599 and IDT70T3589.
2. Pin is a NC for IDT70T3589.
3. All V_{DD} pins must be connected to 2.5V power supply.
4. All V_{DDQ} pins must be connected to appropriate power supply: 3.3V if OPT pin for that port is set to V_{DD} (2.5V), and 2.5V if OPT pin for that port is set to V_{SS} (0V).
5. All V_{SS} pins must be connected to ground supply.
6. Package body is approximately 28mm x 28mm x 3.5mm.
7. This package code is used to reference the package diagram.
8. This text does not indicate orientation of the actual part-marking.
9. Due to limited pin count, JTAG is not supported in the DR208 package.

Pin Configuration ^(3,4,5,6) (con't.)

02/03/14

A1	A2	A3	A4	A5	A6	A7	A8	A9	A10	A11	A12	A13	A14	A15	A16	A17
I/O19L	I/O18L	VSS	TDO	COLL	A16L ⁽²⁾	A12L	A8L	BE1L	VDD	CLKL	CNTENL	A4L	A0L	OPTL	I/O17L	VSS
B1	B2	B3	B4	B5	B6	B7	B8	B9	B10	B11	B12	B13	B14	B15	B16	B17
I/O20R	VSS	I/O18R	TDI	A17L ⁽¹⁾	A13L	A9L	BE2L	CE0L	VSS	ADSL	A5L	A1L	NC	VDDQR	I/O16L	I/O15R
C1	C2	C3	C4	C5	C6	C7	C8	C9	C10	C11	C12	C13	C14	C15	C16	C17
VDDQL	I/O19R	VDDQR	PL/FTL	INTL	A14L	A10L	BE3L	CE1L	VSS	R/WL	A6L	A2L	VDD	I/O16R	I/O15L	VSS
D1	D2	D3	D4	D5	D6	D7	D8	D9	D10	D11	D12	D13	D14	D15	D16	D17
I/O22L	VSS	I/O21L	I/O20L	A15L	A11L	A7L	BE0L	VDD	OEL	REPEATL	A3L	VDD	I/O17R	VDDQL	I/O14L	I/O14R
E1	E2	E3	E4	<p style="text-align: center;">70T3519/99/89BF BF208⁽⁷⁾</p> <p style="text-align: center;">208-Pin fpBGA Top View⁽⁸⁾</p>									E14	E15	E16	E17
I/O23L	I/O22R	VDDQR	I/O21R										I/O12L	I/O13R	VSS	I/O13L
F1	F2	F3	F4										F14	F15	F16	F17
VDDQL	I/O23R	I/O24L	VSS										VSS	I/O12R	I/O11L	VDDQR
G1	G2	G3	G4										G14	G15	G16	G17
I/O26L	VSS	I/O25L	I/O24R										I/O9L	VDDQL	I/O10L	I/O11R
H1	H2	H3	H4										H14	H15	H16	H17
VDD	I/O26R	VDDQR	I/O25R										VDD	I/O9R	VSS	I/O10R
J1	J2	J3	J4										J14	J15	J16	J17
VDDQL	VDD	VSS	ZZR										ZZL	VDD	VSS	VDDQR
K1	K2	K3	K4	K14	K15	K16	K17									
I/O28R	VSS	I/O27R	VSS	I/O7R	VDDQL	I/O8R	VSS									
L1	L2	L3	L4	L14	L15	L16	L17									
I/O29R	I/O28L	VDDQR	I/O27L	I/O6R	I/O7L	VSS	I/O8L									
M1	M2	M3	M4	M14	M15	M16	M17									
VDDQL	I/O29L	I/O30R	VSS	VSS	I/O6L	I/O5R	VDDQR									
N1	N2	N3	N4	N14	N15	N16	N17									
I/O31L	VSS	I/O31R	I/O30L	I/O3R	VDDQL	I/O4R	I/O5L									
P1	P2	P3	P4	P5	P6	P7	P8	P9	P10	P11	P12	P13	P14	P15	P16	P17
I/O32R	I/O32L	VDDQR	I/O35R	TRST	A16R ⁽²⁾	A12R	A8R	BE1R	VDD	CLKR	CNTENR	A4R	I/O2L	I/O3L	VSS	I/O4L
R1	R2	R3	R4	R5	R6	R7	R8	R9	R10	R11	R12	R13	R14	R15	R16	R17
VSS	I/O33L	I/O34R	TCK	A17R ⁽¹⁾	A13R	A9R	BE2R	CE0R	VSS	ADSR	A5R	A1R	NC	VDDQL	I/O1R	VDDQR
T1	T2	T3	T4	T5	T6	T7	T8	T9	T10	T11	T12	T13	T14	T15	T16	T17
I/O33R	I/O34L	VDDQL	TMS	INTR	A14R	A10R	BE3R	CE1R	VSS	R/WR	A6R	A2R	VSS	I/O0R	VSS	I/O2R
U1	U2	U3	U4	U5	U6	U7	U8	U9	U10	U11	U12	U13	U14	U15	U16	U17
VSS	I/O35L	PL/FR	COLR	A15R	A11R	A7R	BE0R	VDD	OER	REPEATR	A3R	A0R	VDD	OPTR	I/O0L	I/O1L

5666 drw 02c

NOTES:

1. Pin is a NC for IDT70T3599 and IDT70T3589.
2. Pin is a NC for IDT70T3589.
3. All VDD pins must be connected to 2.5V power supply.
4. All VDDQ pins must be connected to appropriate power supply: 3.3V if OPT pin for that port is set to VDD (2.5V), and 2.5V if OPT pin for that port is set to VSS (0V).
5. All VSS pins must be connected to ground supply.
6. Package body is approximately 15mm x 15mm x 1.4mm with 0.8mm ball pitch.
7. This package code is used to reference the package diagram.
8. This text does not indicate orientation of the actual part-marking.

Pin Names

Left Port	Right Port	Names
\overline{CE}_{0L} , CE_{1L}	\overline{CE}_{0R} , CE_{1R}	Chip Enables (Input) ⁽⁷⁾
R/\overline{W}_L	R/\overline{W}_R	Read/Write Enable (Input)
\overline{OE}_L	\overline{OE}_R	Output Enable (Input)
A_{0L} - A_{17L} ⁽⁶⁾	A_{0R} - A_{17R} ⁽⁶⁾	Address (Input)
I/O_{0L} - I/O_{35L}	I/O_{0R} - I/O_{35R}	Data Input/Output
CLK_L	CLK_R	Clock (Input)
PL/\overline{FT}_L	PL/\overline{FT}_R	Pipeline/Flow-Through (Input)
\overline{ADS}_L	\overline{ADS}_R	Address Strobe Enable (Input)
\overline{CNTEN}_L	\overline{CNTEN}_R	Counter Enable (Input)
\overline{REPEAT}_L	\overline{REPEAT}_R	Counter Repeat ⁽³⁾
\overline{BE}_{0L} - \overline{BE}_{3L}	\overline{BE}_{0R} - \overline{BE}_{3R}	Byte Enables (9-bit bytes) (Input) ⁽⁷⁾
V_{DD0L}	V_{DD0R}	Power (I/O Bus) (3.3V or 2.5V) ⁽¹⁾ (Input)
OPT_L	OPT_R	Option for selecting V_{DD0x} ^(1,2) (Input)
ZZ_L	ZZ_R	Sleep Mode pin ⁽⁴⁾ (Input)
V_{DD}		Power (2.5V) ⁽¹⁾ (Input)
V_{SS}		Ground (0V) (Input)
$TDI^{(5)}$		Test Data Input
$TDO^{(5)}$		Test Data Output
$TCK^{(5)}$		Test Logic Clock (10MHz) (Input)
$TMS^{(5)}$		Test Mode Select (Input)
$\overline{TRST}^{(5)}$		Reset (Initialize TAP Controller) (Input)
\overline{INT}_L	\overline{INT}_R	Interrupt Flag (Output)
\overline{COL}_L	\overline{COL}_R	Collision Alert (Output)

5666 tbl 01

NOTES:

- V_{DD} , OPT_x , and V_{DD0x} must be set to appropriate operating levels prior to applying inputs on the I/Os and controls for that port.
- OPT_x selects the operating voltage levels for the I/Os and controls on that port. If OPT_x is set to V_{DD} (2.5V), then that port's I/Os and controls will operate at 3.3V levels and V_{DD0x} must be supplied at 3.3V. If OPT_x is set to V_{SS} (0V), then that port's I/Os and address controls will operate at 2.5V levels and V_{DD0x} must be supplied at 2.5V. The OPT pins are independent of one another—both ports can operate at 3.3V levels, both can operate at 2.5V levels, or either can operate at 3.3V with the other at 2.5V.
- When \overline{REPEAT}_x is asserted, the counter will reset to the last valid address loaded via \overline{ADS}_x .
- The sleep mode pin shuts off all dynamic inputs, except JTAG inputs, when asserted. All static inputs, i.e., PL/\overline{FT}_x and OPT_x and the sleep mode pins themselves (ZZ_x) are not affected during sleep mode. It is recommended that boundary scan not be operated during sleep mode.
- Due to limited pin count, JTAG is not supported in the DR208 package.
- Address A_{17x} is a NC for the IDT70T3599. Also, Addresses A_{17x} and A_{16x} are NC's for the IDT 70T3589.
- Chip Enables and Byte Enables are double buffered when $PL/\overline{FT} = V_{IH}$, i.e., the signals take two cycles to deselect.

Truth Table I—Read/Write and Enable Control (1,2,3,4)

OE	CLK	CE0	CE1	BE3	BE2	BE1	BE0	R/W	ZZ	Byte 3 I/O27-35	Byte 2 I/O18-26	Byte 1 I/O9-17	Byte 0 I/O0-8	MODE
X	↑	H	X	X	X	X	X	X	L	High-Z	High-Z	High-Z	High-Z	Deselected—Power Down
X	↑	X	L	X	X	X	X	X	L	High-Z	High-Z	High-Z	High-Z	Deselected—Power Down
X	↑	L	H	H	H	H	H	X	L	High-Z	High-Z	High-Z	High-Z	All Bytes Deselected
X	↑	L	H	H	H	H	L	L	L	High-Z	High-Z	High-Z	DIN	Write to Byte 0 Only
X	↑	L	H	H	H	L	H	L	L	High-Z	High-Z	DIN	High-Z	Write to Byte 1 Only
X	↑	L	H	H	L	H	H	L	L	High-Z	DIN	High-Z	High-Z	Write to Byte 2 Only
X	↑	L	H	L	H	H	H	L	L	DIN	High-Z	High-Z	High-Z	Write to Byte 3 Only
X	↑	L	H	H	H	L	L	L	L	High-Z	High-Z	DIN	DIN	Write to Lower 2 Bytes Only
X	↑	L	H	L	L	H	H	L	L	DIN	DIN	High-Z	High-Z	Write to Upper 2 bytes Only
X	↑	L	H	L	L	L	L	L	L	DIN	DIN	DIN	DIN	Write to All Bytes
L	↑	L	H	H	H	H	L	H	L	High-Z	High-Z	High-Z	DOUT	Read Byte 0 Only
L	↑	L	H	H	H	L	H	H	L	High-Z	High-Z	DOUT	High-Z	Read Byte 1 Only
L	↑	L	H	H	L	H	H	H	L	High-Z	DOUT	High-Z	High-Z	Read Byte 2 Only
L	↑	L	H	L	H	H	H	H	L	DOUT	High-Z	High-Z	High-Z	Read Byte 3 Only
L	↑	L	H	H	H	L	L	H	L	High-Z	High-Z	DOUT	DOUT	Read Lower 2 Bytes Only
L	↑	L	H	L	L	H	H	H	L	DOUT	DOUT	High-Z	High-Z	Read Upper 2 Bytes Only
L	↑	L	H	L	L	L	L	H	L	DOUT	DOUT	DOUT	DOUT	Read All Bytes
H	↑	X	X	X	X	X	X	X	L	High-Z	High-Z	High-Z	High-Z	Outputs Disabled
X	X	X	X	X	X	X	X	X	H	High-Z	High-Z	High-Z	High-Z	Sleep Mode

5666 tbl 02

NOTES:

1. "H" = VIH, "L" = VIL, "X" = Don't Care.
2. ADS, CNTEN, REPEAT = X.
3. OE and ZZ are asynchronous input signals.
4. It is possible to read or write any combination of bytes during a given access. A few representative samples have been illustrated here.

Truth Table II—Address Counter Control (1,2)

Address	Previous Internal Address	Internal Address Used	CLK	ADS	CNTEN	REPEAT ⁽⁶⁾	I/O ⁽³⁾	MODE
An	X	An	↑	L ⁽⁴⁾	X	H	D _{IO} (n)	External Address Used
X	An	An + 1	↑	H	L ⁽⁵⁾	H	D _{IO} (n+1)	Counter Enabled—Internal Address generation
X	An + 1	An + 1	↑	H	H	H	D _{IO} (n+1)	External Address Blocked—Counter disabled (An + 1 reused)
X	X	An	↑	X	X	L ⁽⁴⁾	D _{IO} (n)	Counter Set to last valid ADS load

5666 tbl 03

NOTES:

1. "H" = VIH, "L" = VIL, "X" = Don't Care.
2. Read and write operations are controlled by the appropriate setting of R/W, CE0, CE1, BE_n and OE.
3. Outputs configured in flow-through output mode: if outputs are in pipelined mode the data out will be delayed by one cycle.
4. ADS and REPEAT are independent of all other memory control signals including CE0, CE1 and BE_n.
5. The address counter advances if CNTEN = VIL on the rising edge of CLK, regardless of all other memory control signals including CE0, CE1, BE_n.
6. When REPEAT is asserted, the counter will reset to the last valid address loaded via ADS. This value is not set at power-up: a known location should be loaded via ADS during initialization if desired. Any subsequent ADS access during operations will update the REPEAT address location.

Recommended Operating Temperature and Supply Voltage ⁽¹⁾

Grade	Ambient Temperature	GND	V _{DD}
Commercial	0°C to +70°C	0V	2.5V ± 100mV
Industrial	-40°C to +85°C	0V	2.5V ± 100mV

5666 tbl 04

NOTES:

1. This is the parameter TA. This is the "instant on" case temperature.

Recommended DC Operating Conditions with V_{DDQ} at 2.5V

Symbol	Parameter	Min.	Typ.	Max.	Unit
V _{DD}	Core Supply Voltage	2.4	2.5	2.6	V
V _{DDQ}	I/O Supply Voltage ⁽³⁾	2.4	2.5	2.6	V
V _{SS}	Ground	0	0	0	V
V _{IH}	Input High Voltage (Address, Control & Data I/O Inputs) ⁽³⁾	1.7	—	V _{DDQ} + 100mV ⁽²⁾	V
V _{IH}	Input High Voltage - JTAG	1.7	—	V _{DD} + 100mV ⁽²⁾	V
V _{IH}	Input High Voltage - ZZ, OPT, PIPE/FT	V _{DD} - 0.2V	—	V _{DD} + 100mV ⁽²⁾	V
V _{IL}	Input Low Voltage	-0.3 ⁽¹⁾	—	0.7	V
V _{IL}	Input Low Voltage - ZZ, OPT, PIPE/FT	-0.3 ⁽¹⁾	—	0.2	V

5666 tbl 05a

NOTES:

1. V_{IL} (min.) = -1.0V for pulse width less than tcyc/2 or 5ns, whichever is less.
2. V_{IH} (max.) = V_{DDQ} + 1.0V for pulse width less than tcyc/2 or 5ns, whichever is less.
3. To select operation at 2.5V levels on the I/Os and controls of a given port, the OPT pin for that port must be set to V_{SS}(0V), and V_{DDQ} for that port must be supplied as indicated above.

Recommended DC Operating Conditions with V_{DDQ} at 3.3V

Symbol	Parameter	Min.	Typ.	Max.	Unit
V _{DD}	Core Supply Voltage	2.4	2.5	2.6	V
V _{DDQ}	I/O Supply Voltage ⁽³⁾	3.15	3.3	3.45	V
V _{SS}	Ground	0	0	0	V
V _{IH}	Input High Voltage (Address, Control & Data I/O Inputs) ⁽³⁾	2.0	—	V _{DDQ} + 150mV ⁽²⁾	V
V _{IH}	Input High Voltage - JTAG	1.7	—	V _{DD} + 100mV ⁽²⁾	V
V _{IH}	Input High Voltage - ZZ, OPT, PIPE/FT	V _{DD} - 0.2V	—	V _{DD} + 100mV ⁽²⁾	V
V _{IL}	Input Low Voltage	-0.3 ⁽¹⁾	—	0.8	V
V _{IL}	Input Low Voltage - ZZ, OPT, PIPE/FT	-0.3 ⁽¹⁾	—	0.2	V

5666 tbl 05b

NOTES:

1. V_{IL} (min.) = -1.0V for pulse width less than tcyc/2, or 5ns, whichever is less.
2. V_{IH} (max.) = V_{DDQ} + 1.0V for pulse width less than tcyc/2 or 5ns, whichever is less.
3. To select operation at 3.3V levels on the I/Os and controls of a given port, the OPT pin for that port must be set to V_{DD} (2.5V), and V_{DDQ} for that port must be supplied as indicated above.

Absolute Maximum Ratings ⁽¹⁾

Symbol	Rating	Commercial & Industrial	Unit
V _{TERM} (V _{DD})	V _{DD} Terminal Voltage with Respect to GND	-0.5 to 3.6	V
V _{TERM} ⁽²⁾ (V _{DDQ})	V _{DDQ} Terminal Voltage with Respect to GND	-0.3 to V _{DDQ} + 0.3	V
V _{TERM} ⁽²⁾ (INPUTS and I/O's)	Input and I/O Terminal Voltage with Respect to GND	-0.3 to V _{DDQ} + 0.3	V
T _{BIAS} ⁽³⁾	Temperature Under Bias	-55 to +125	°C
T _{STG}	Storage Temperature	-65 to +150	°C
T _{JN}	Junction Temperature	+150	°C
I _{OUT} (For V _{DDQ} = 3.3V)	DC Output Current	50	mA
I _{OUT} (For V _{DDQ} = 2.5V)	DC Output Current	40	mA

5666 tbl 06

NOTES:

- Stresses greater than those listed under ABSOLUTE MAXIMUM RATINGS may cause permanent damage to the device. This is a stress rating only and functional operation of the device at these or any other conditions above those indicated in the operational sections of this specification is not implied. Exposure to absolute maximum rating conditions for extended periods may affect reliability.
- This is a steady-state DC parameter that applies after the power supply has reached its nominal operating value. Power sequencing is not necessary; however, the voltage on any Input or I/O pin cannot exceed V_{DDQ} during power supply ramp up.
- Ambient Temperature under DC Bias. No AC Conditions. Chip Deselected.

Capacitance ⁽¹⁾(T_A = +25°C, F = 1.0MHz) PQFP ONLY

Symbol	Parameter	Conditions ⁽²⁾	Max.	Unit
C _{IN}	Input Capacitance	V _{IN} = 3dV	8	pF
C _{OUT} ⁽³⁾	Output Capacitance	V _{OUT} = 3dV	10.5	pF

5666 tbl 07

NOTES:

- These parameters are determined by device characterization, but are not production tested.
- 3dV references the interpolated capacitance when the input and output switch from 0V to 3V or from 3V to 0V.
- C_{OUT} also references C_{IO}.

DC Electrical Characteristics Over the Operating Temperature and Supply Voltage Range (V_{DD} = 2.5V ± 100mV)

Symbol	Parameter	Test Conditions	70T3519/99/89S		Unit
			Min.	Max.	
I _{LI}	Input Leakage Current ⁽¹⁾	V _{DDQ} = Max., V _{IN} = 0V to V _{DDQ}	—	10	μA
I _{LI}	JTAG & ZZ Input Leakage Current ^(1,2)	V _{DD} = Max., V _{IN} = 0V to V _{DD}	—	±30	μA
I _{LO}	Output Leakage Current ^(1,3)	$\overline{CE}_0 = V_{IH}$ or $CE_1 = V_{IL}$, V _{OUT} = 0V to V _{DDQ}	—	10	μA
V _{OL} (3.3V)	Output Low Voltage ⁽¹⁾	I _{OL} = +4mA, V _{DDQ} = Min.	—	0.4	V
V _{OH} (3.3V)	Output High Voltage ⁽¹⁾	I _{OH} = -4mA, V _{DDQ} = Min.	2.4	—	V
V _{OL} (2.5V)	Output Low Voltage ⁽¹⁾	I _{OL} = +2mA, V _{DDQ} = Min.	—	0.4	V
V _{OH} (2.5V)	Output High Voltage ⁽¹⁾	I _{OH} = -2mA, V _{DDQ} = Min.	2.0	—	V

5666 tbl 08

NOTES:

- V_{DDQ} is selectable (3.3V/2.5V) via OPT pins. Refer to p.5 for details.
- Applicable only for TMS, TDI and TRST inputs.
- Outputs tested in tri-state mode.

DC Electrical Characteristics Over the Operating Temperature and Supply Voltage Range ⁽³⁾ ($V_{DD} = 2.5V \pm 100mV$)

Symbol	Parameter	Test Condition	Version	70T3519/99/89 S200 Com'l Only ⁽⁶⁾		70T3519/99/89 S166 Com'l & Ind ⁽⁷⁾		70T3519/99/89 S133 Com'l & Ind		Unit	
				Typ. ⁽⁴⁾	Max.	Typ. ⁽⁴⁾	Max.	Typ. ⁽⁴⁾	Max.		
IDD	Dynamic Operating Current (Both Ports Active)	\overline{CE}_L and $\overline{CE}_R = V_{IL}$, Outputs Disabled, $f = f_{MAX}^{(1)}$	COM'L	S	375	525	320	450	260	370	mA
			IND	S	—	—	320	510	260	450	
ISB1 ⁽⁶⁾	Standby Current (Both Ports - TTL Level Inputs)	$\overline{CE}_L = \overline{CE}_R = V_{IH}$ $f = f_{MAX}^{(1)}$	COM'L	S	205	270	175	230	140	190	mA
			IND	S	—	—	175	275	140	235	
ISB2 ⁽⁶⁾	Standby Current (One Port - TTL Level Inputs)	$\overline{CE}^*A = V_{IL}$ and $\overline{CE}^*B = V_{IH}^{(6)}$ Active Port Outputs Disabled, $f = f_{MAX}^{(1)}$	COM'L	S	300	375	250	325	200	250	mA
			IND	S	—	—	250	365	200	310	
ISB3	Full Standby Current (Both Ports - CMOS Level Inputs)	Both Ports \overline{CE}_L and $\overline{CE}_R \geq V_{DDQ} - 0.2V$, $V_{IN} \geq V_{DDQ} - 0.2V$ or $V_{IN} \leq 0.2V$, $f = 0^{(2)}$	COM'L	S	5	15	5	15	5	15	mA
			IND	S	—	—	5	20	5	20	
ISB4 ⁽⁶⁾	Full Standby Current (One Port - CMOS Level Inputs)	$\overline{CE}^*A \leq 0.2V$ and $\overline{CE}^*B \geq V_{DDQ} - 0.2V^{(6)}$ $V_{IN} \geq V_{DDQ} - 0.2V$ or $V_{IN} \leq 0.2V$ Active Port, Outputs Disabled, $f = f_{MAX}^{(1)}$	COM'L	S	300	375	250	325	200	250	mA
			IND	S	—	—	250	365	200	310	
Izz	Sleep Mode Current (Both Ports - TTL Level Inputs)	$ZZ_L = ZZ_R = V_{IH}$ $f = f_{MAX}^{(1)}$	COM'L	S	5	15	5	15	5	15	mA
			IND	S	—	—	5	20	5	20	

5666 tbl 09

NOTES:

- At $f = f_{MAX}$, address and control lines (except Output Enable) are cycling at the maximum frequency clock cycle of $1/t_{cvc}$, using "AC TEST CONDITIONS".
- $f = 0$ means no address, clock, or control lines change. Applies only to input at CMOS level standby.
- Port "A" may be either left or right port. Port "B" is the opposite from port "A".
- $V_{DD} = 2.5V$, $T_A = 25^\circ C$ for Typ, and are not production tested. $I_{DD} DC(f=0) = 15mA$ (Typ).
- $\overline{CE}_X = V_{IL}$ means $\overline{CE}_{0X} = V_{IL}$ and $CE_{1X} = V_{IH}$
 $\overline{CE}_X = V_{IH}$ means $\overline{CE}_{0X} = V_{IH}$ or $CE_{1X} = V_{IL}$
 $\overline{CE}_X \leq 0.2V$ means $\overline{CE}_{0X} \leq 0.2V$ and $CE_{1X} \geq V_{DDQ} - 0.2V$
 $\overline{CE}_X \geq V_{DDQ} - 0.2V$ means $\overline{CE}_{0X} \geq V_{DDQ} - 0.2V$ or $CE_{1X} \leq 0.2V$
"X" represents "L" for left port or "R" for right port.
- ISB1, ISB2 and ISB4 will all reach full standby levels (ISB3) on the appropriate port(s) if ZZ_L and/or $ZZ_R = V_{IH}$.
- 166MHz I-Temp is not available in the BF208 package.
- 200Mhz is not available in the BF208 and DR208 packages.

AC Test Conditions (V_{DDQ} - 3.3V/2.5V)

Input Pulse Levels (Address & Controls)	GND to 3.0V/GND to 2.4V
Input Pulse Levels (I/Os)	GND to 3.0V/GND to 2.4V
Input Rise/Fall Times	2ns
Input Timing Reference Levels	1.5V/1.25V
Output Reference Levels	1.5V/1.25V
Output Load	Figure 1

5666 tbl 10

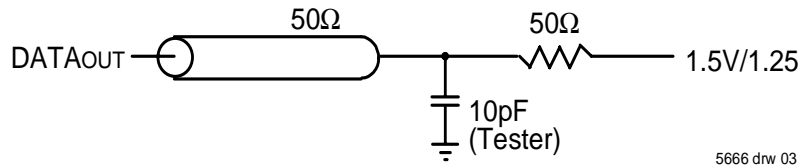

5666 drw 03

Figure 1. AC Output Test load.

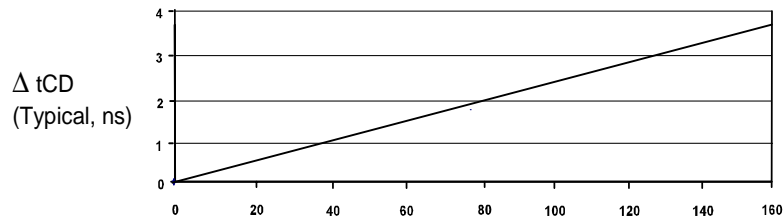

Δ Capacitance (pF) from AC Test Load

5666 drw 04

AC Electrical Characteristics Over the Operating Temperature Range (Read and Write Cycle Timing) ^(2,3) ($V_{DD} = 2.5V \pm 100mV$, $T_A = 0^{\circ}C$ to $+70^{\circ}C$)

Symbol	Parameter	70T3519/99/89 S200 Com'l Only ⁽⁵⁾		70T3519/99/89 S166 Com'l & Ind ⁽⁴⁾		70T3519/99/89 S133 Com'l & Ind		Unit
		Min.	Max.	Min.	Max.	Min.	Max.	
t _{CYC1}	Clock Cycle Time (Flow-Through) ⁽¹⁾	15	—	20	—	25	—	ns
t _{CYC2}	Clock Cycle Time (Pipelined) ⁽¹⁾	5	—	6	—	7.5	—	ns
t _{CH1}	Clock High Time (Flow-Through) ⁽¹⁾	6	—	8	—	10	—	ns
t _{CL1}	Clock Low Time (Flow-Through) ⁽¹⁾	6	—	8	—	10	—	ns
t _{CH2}	Clock High Time (Pipelined) ⁽²⁾	2	—	2.4	—	3	—	ns
t _{CL2}	Clock Low Time (Pipelined) ⁽¹⁾	2	—	2.4	—	3	—	ns
t _{SA}	Address Setup Time	1.5	—	1.7	—	1.8	—	ns
t _{HA}	Address Hold Time	0.5	—	0.5	—	0.5	—	ns
t _{SC}	Chip Enable Setup Time	1.5	—	1.7	—	1.8	—	ns
t _{HC}	Chip Enable Hold Time	0.5	—	0.5	—	0.5	—	ns
t _{SB}	Byte Enable Setup Time	1.5	—	1.7	—	1.8	—	ns
t _{HB}	Byte Enable Hold Time	0.5	—	0.5	—	0.5	—	ns
t _{SW}	R/W Setup Time	1.5	—	1.7	—	1.8	—	ns
t _{HW}	R/W Hold Time	0.5	—	0.5	—	0.5	—	ns
t _{SD}	Input Data Setup Time	1.5	—	1.7	—	1.8	—	ns
t _{HD}	Input Data Hold Time	0.5	—	0.5	—	0.5	—	ns
t _{SAD}	\overline{ADS} Setup Time	1.5	—	1.7	—	1.8	—	ns
t _{HAD}	\overline{ADS} Hold Time	0.5	—	0.5	—	0.5	—	ns
t _{SCN}	\overline{CNTEN} Setup Time	1.5	—	1.7	—	1.8	—	ns
t _{HCN}	\overline{CNTEN} Hold Time	0.5	—	0.5	—	0.5	—	ns
t _{SRPT}	\overline{REPEAT} Setup Time	1.5	—	1.7	—	1.8	—	ns
t _{HRPT}	\overline{REPEAT} Hold Time	0.5	—	0.5	—	0.5	—	ns
t _{OE}	Output Enable to Data Valid	—	4.4	—	4.4	—	4.6	ns
t _{OLZ} ⁽⁶⁾	Output Enable to Output Low-Z	1	—	1	—	1	—	ns
t _{OHZ} ⁽⁶⁾	Output Enable to Output High-Z	1	3.4	1	3.6	1	4.2	ns
t _{CD1}	Clock to Data Valid (Flow-Through) ⁽¹⁾	—	10	—	12	—	15	ns
t _{CD2}	Clock to Data Valid (Pipelined) ⁽¹⁾	—	3.4	—	3.6	—	4.2	ns
t _{DC}	Data Output Hold After Clock High	1	—	1	—	1	—	ns
t _{CKHZ} ⁽⁶⁾	Clock High to Output High-Z	1	3.4	1	3.6	1	4.2	ns
t _{CKLZ} ⁽⁶⁾	Clock High to Output Low-Z	1	—	1	—	1	—	ns
t _{INS}	Interrupt Flag Set Time	—	7	—	7	—	7	ns
t _{INR}	Interrupt Flag Reset Time	—	7	—	7	—	7	ns
t _{COLS}	Collision Flag Set Time	—	3.4	—	3.6	—	4.2	ns
t _{COLR}	Collision Flag Reset Time	—	3.4	—	3.6	—	4.2	ns
t _{ZZSC}	Sleep Mode Set Cycles	2	—	2	—	2	—	cycles
t _{ZZRC}	Sleep Mode Recovery Cycles	3	—	3	—	3	—	cycles
Port-to-Port Delay								
t _{CO}	Clock-to-Clock Offset	4	—	5	—	6	—	ns
t _{OFs}	Clock-to-Clock Offset for Collision Detection	Please refer to Collision Detection Timing Table on Page 21						

NOTES:

5666 tbl 11

- The Pipelined output parameters (t_{CYC2}, t_{CD2}) apply to either or both left and right ports when $PL/\overline{FT}x = V_{DD}$ (2.5V). Flow-through parameters (t_{CYC1}, t_{CD1}) apply when $PL/\overline{FT} = V_{SS}$ (0V) for that port.
- All input signals are synchronous with respect to the clock except for the asynchronous Output Enable (\overline{OE}), PL/\overline{FT} and OPT. PL/\overline{FT} and OPT should be treated as DC signals, i.e. steady state during operation.
- These values are valid for either level of V_{DD0} (3.3V/2.5V). See page 6 for details on selecting the desired operating voltage levels for each port.
- 166MHz I-Temp is not available in the BF208 package.
- 200Mhz is not available in the BF208 and DR208 packages.
- Guaranteed by design (not production tested).

Timing Waveform of Read Cycle for Pipelined Operation ($\overline{FT}/PIPE^*X = V_{IH}$)^(1,2)

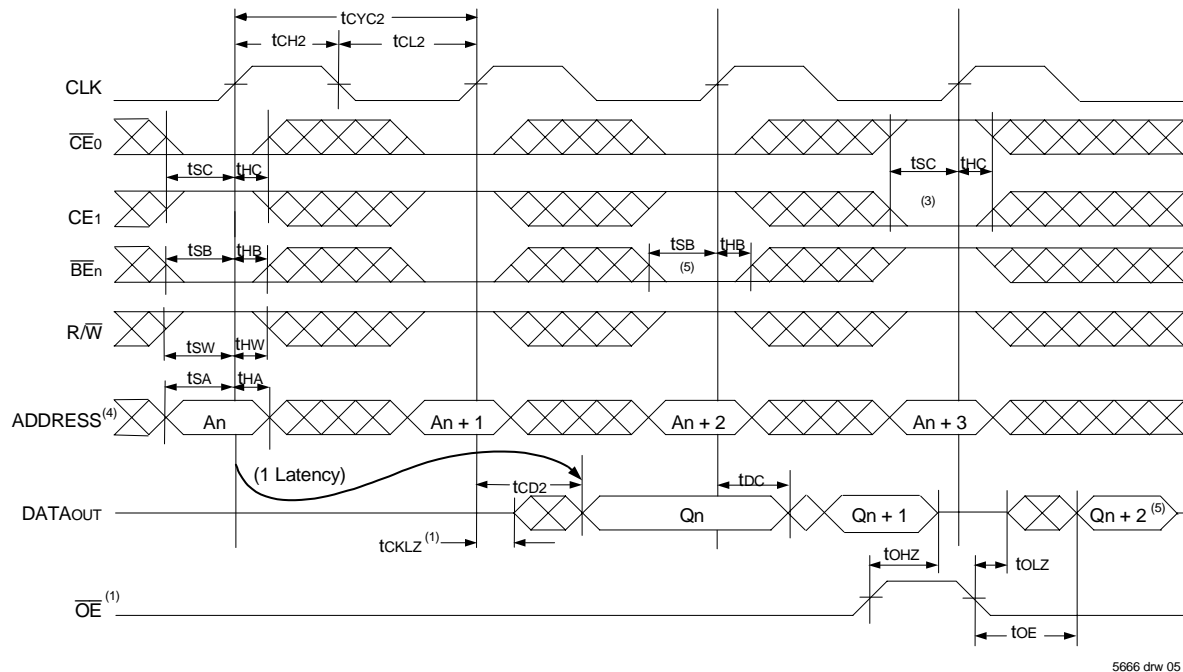

5666 drw 05

Timing Waveform of Read Cycle for Flow-through Output ($\overline{FT}/PIPE^*X = V_{IL}$)^(1,2,6)

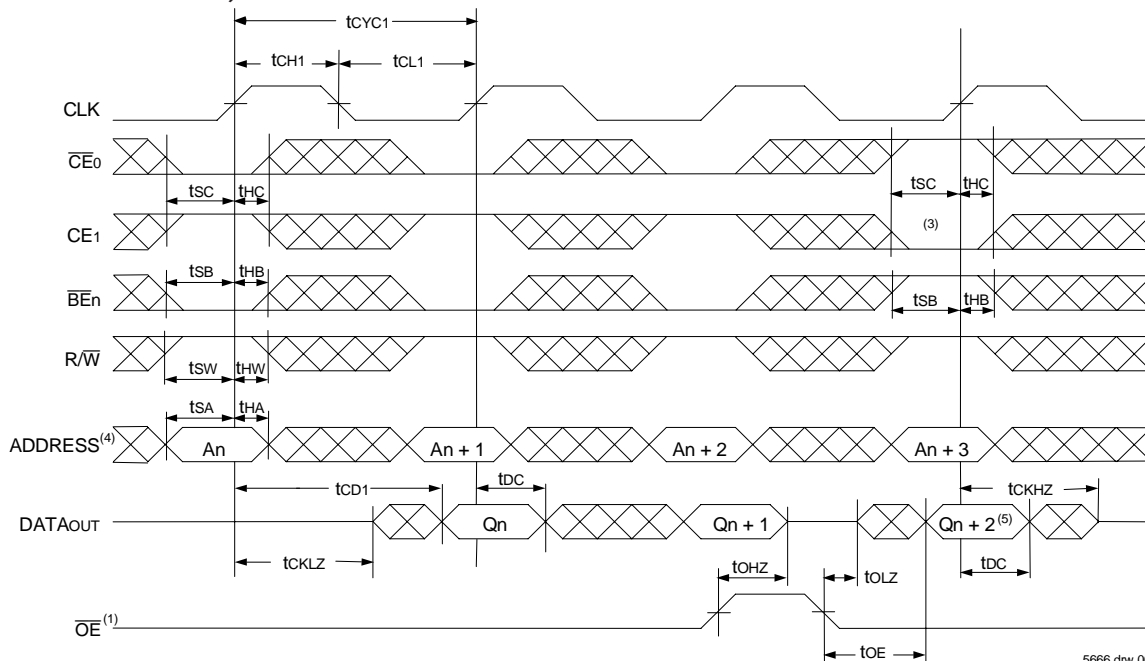

5666 drw 06

NOTES:

- \overline{OE} is asynchronously controlled; all other inputs depicted in the above waveforms are synchronous to the rising clock edge.
- $\overline{ADS} = V_{IL}$, \overline{CNTEN} and $\overline{REPEAT} = V_{IH}$.
- The output is disabled (High-Impedance state) by $\overline{CE}_0 = V_{IH}$, $\overline{CE}_1 = V_{IL}$, $\overline{BE}_n = V_{IH}$ following the next rising edge of the clock. Refer to Truth Table 1.
- Addresses do not have to be accessed sequentially since $\overline{ADS} = V_{IL}$ constantly loads the address on the rising edge of the CLK; numbers are for reference use only.
- If \overline{BE}_n was HIGH, then the appropriate Byte of DATAout for Q_{n+2} would be disabled (High-Impedance state).
- "x" denotes Left or Right port. The diagram is with respect to that port.

Timing Waveform of a Multi-Device Pipelined Read (1,2)

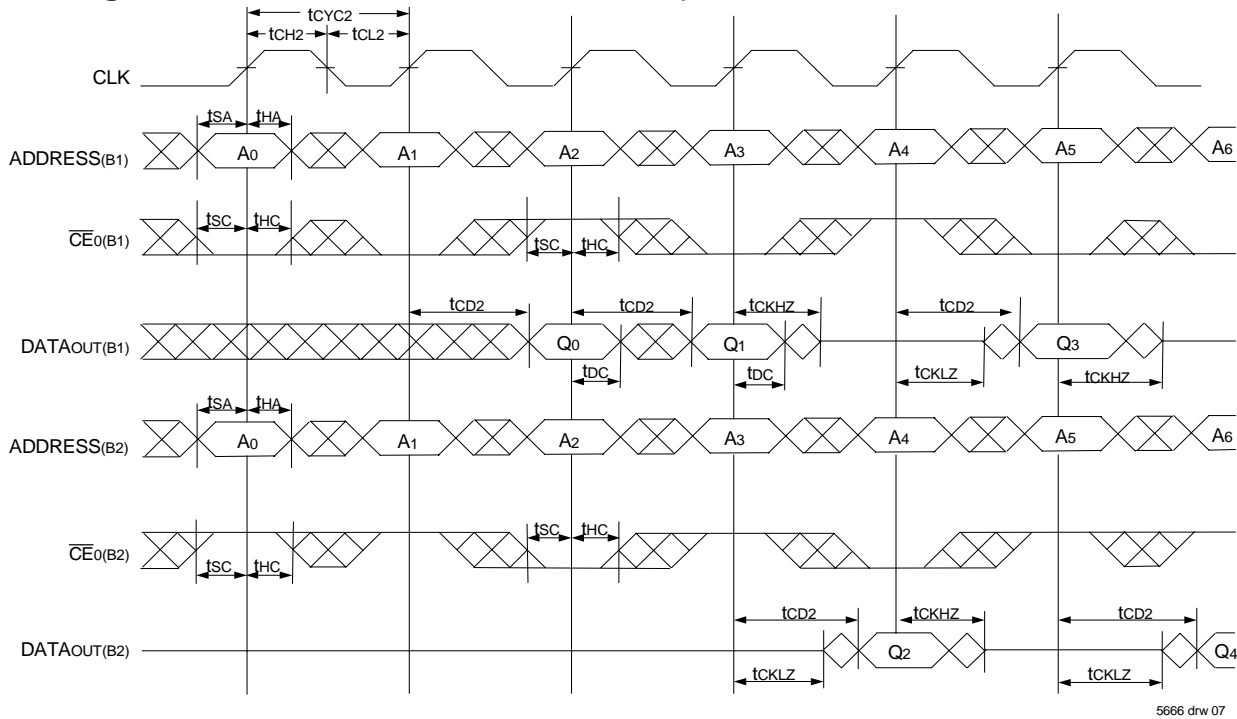

5666 drw 07

Timing Waveform of a Multi-Device Flow-Through Read (1,2)

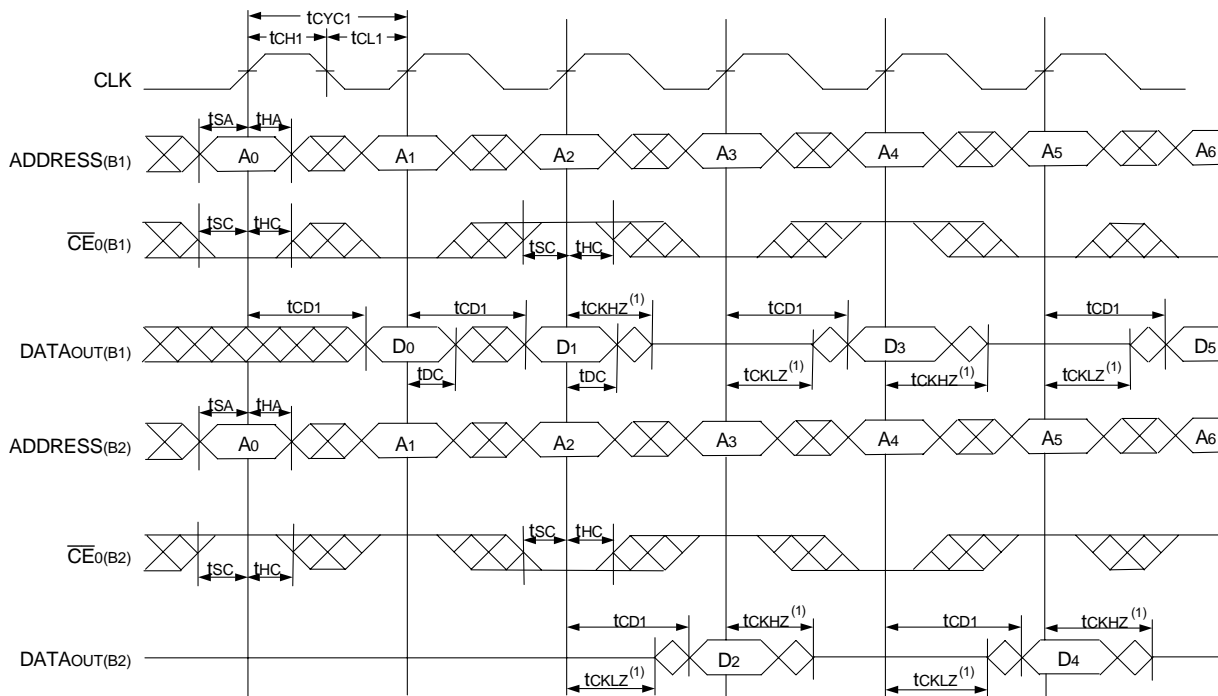

5666 drw 08

NOTES:

1. B1 Represents Device #1; B2 Represents Device #2. Each Device consists of one IDT70T3519/99/89 for this waveform, and are setup for depth expansion in this example. ADDRESS(B1) = ADDRESS(B2) in this situation.
2. \overline{BE}_n , OE, and ADS = V_{IL}; CE1(B1), CE1(B2), R/W, CNTEN, and REPEAT = V_{IH}.

Timing Waveform of Pipelined Read-to-Write-to-Read

($\overline{OE} = V_{IL}$)⁽²⁾

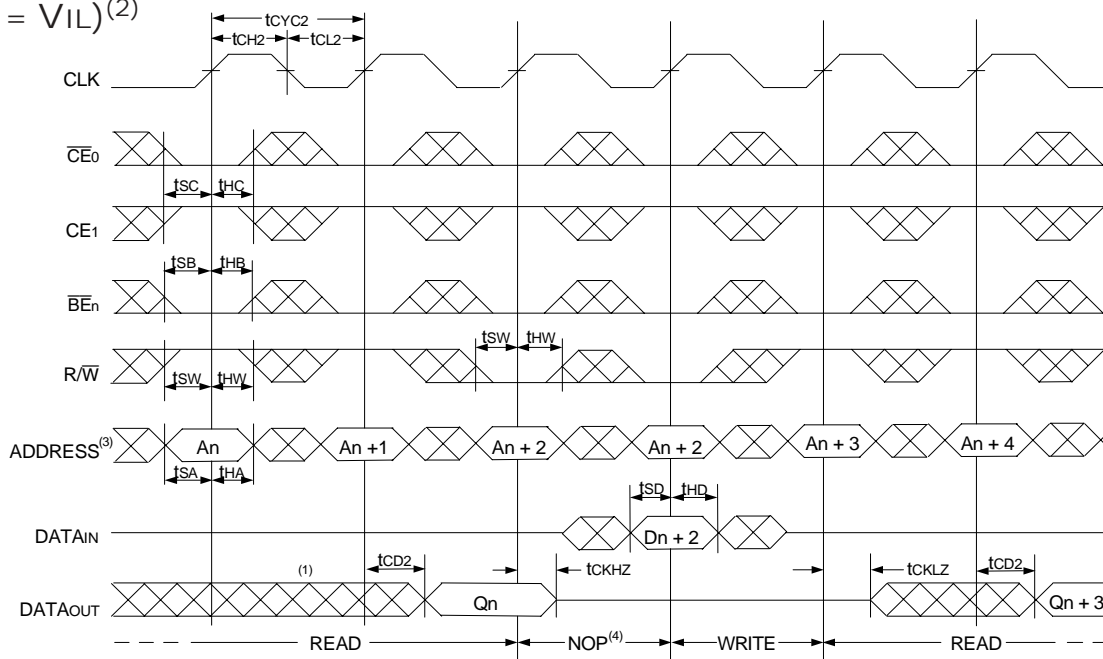

5666 drw 11

NOTES:

1. Output state (High, Low, or High-impedance) is determined by the previous cycle control signals.
2. \overline{CE}_0 , \overline{BE}_n , and $\overline{ADS} = V_{IL}$; \overline{CE}_1 , \overline{CNTEN} , and $\overline{REPEAT} = V_{IH}$. "NOP" is "No Operation".
3. Addresses do not have to be accessed sequentially since $\overline{ADS} = V_{IL}$ constantly loads the address on the rising edge of the CLK; numbers are for reference use only.
4. "NOP" is "No Operation." Data in memory at the selected address may be corrupted and should be re-written to guarantee data integrity.

Timing Waveform of Pipelined Read-to-Write-to-Read (\overline{OE} Controlled)⁽²⁾

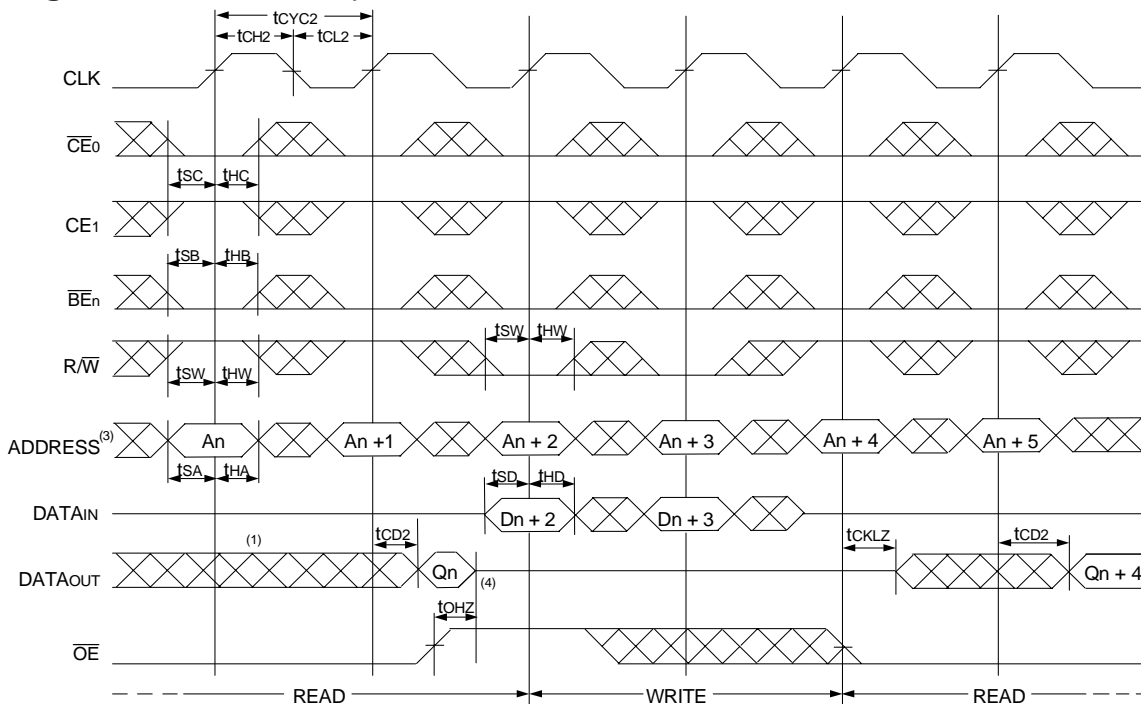

5666 drw 12

NOTES:

1. Output state (High, Low, or High-impedance) is determined by the previous cycle control signals.
2. \overline{CE}_0 , \overline{BE}_n , and $\overline{ADS} = V_{IL}$; \overline{CE}_1 , \overline{CNTEN} , and $\overline{REPEAT} = V_{IH}$.
3. Addresses do not have to be accessed sequentially since $\overline{ADS} = V_{IL}$ constantly loads the address on the rising edge of the CLK; numbers are for reference use only.
4. This timing does not meet requirements for fastest speed grade. This waveform indicates how logically it could be done if timing so allows.

Timing Waveform of Flow-Through Read-to-Write-to-Read ($\overline{OE} = V_{IL}$)⁽²⁾

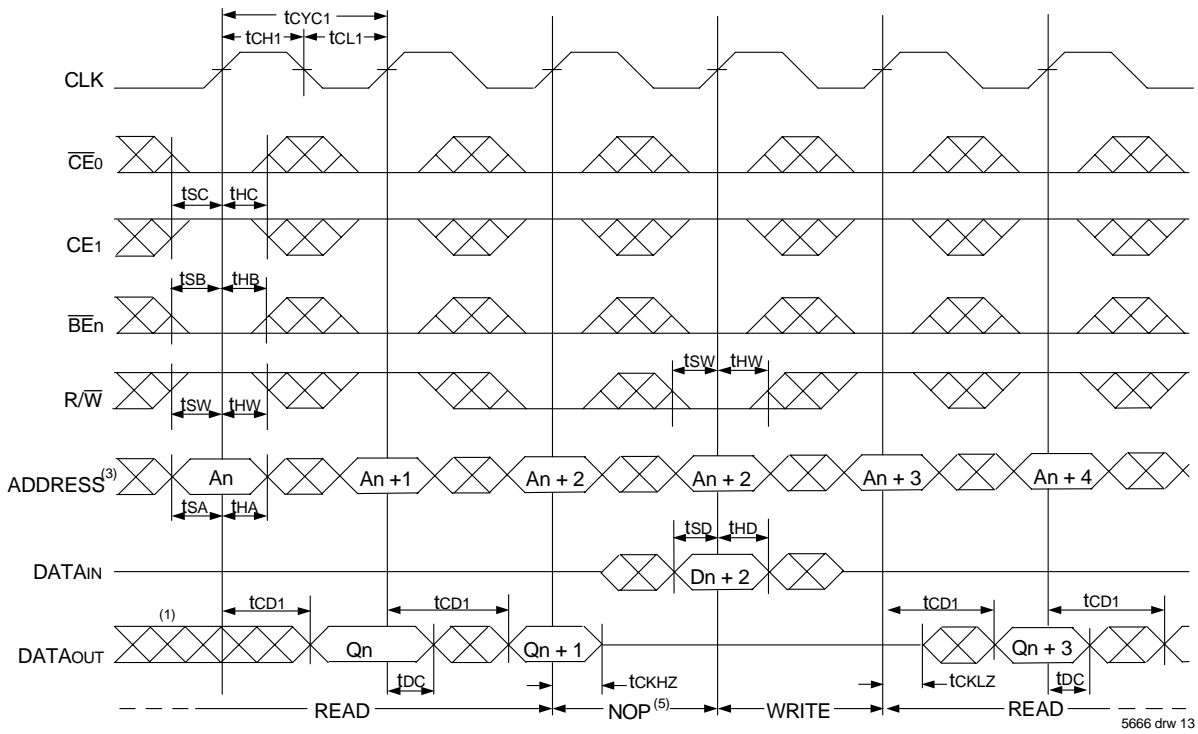

Timing Waveform of Flow-Through Read-to-Write-to-Read (\overline{OE} Controlled)⁽²⁾

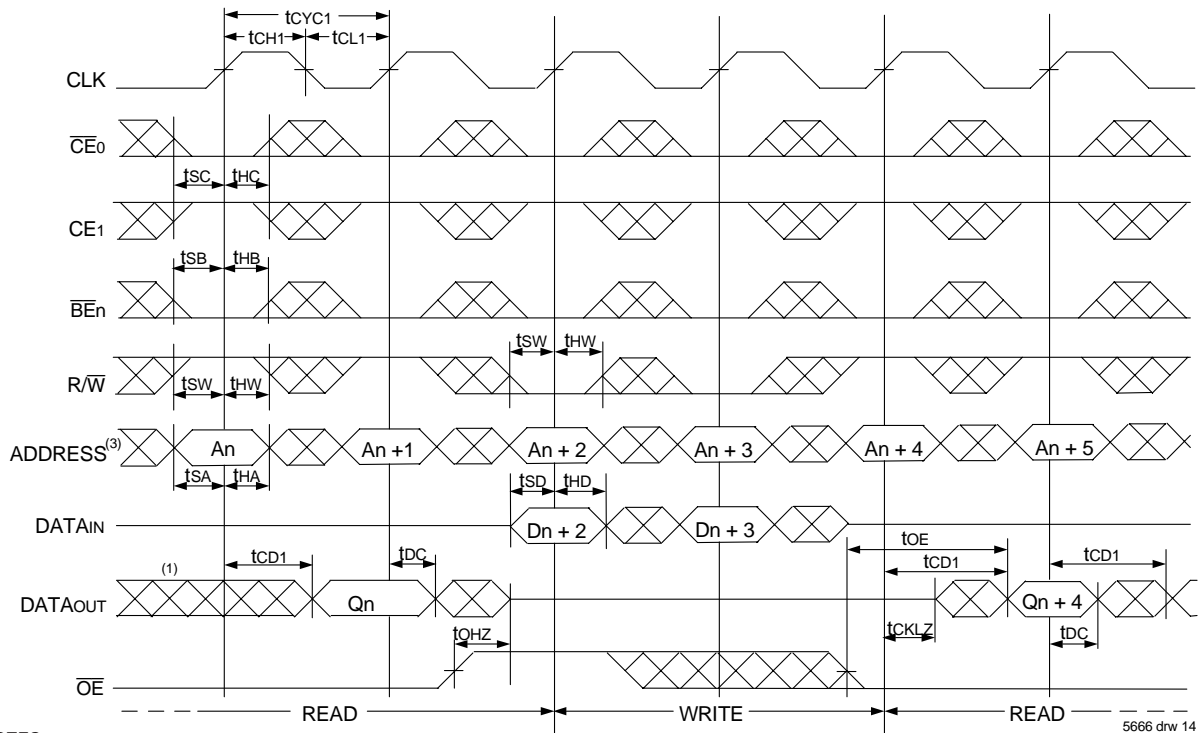

NOTES:

1. Output state (High, Low, or High-impedance) is determined by the previous cycle control signals.
2. \overline{CE}_0 , \overline{BEn} , and $\overline{ADS} = V_{IL}$; CE_1 , $CNTEN$, and $REPEAT = V_{IH}$.
3. Addresses do not have to be accessed sequentially since $\overline{ADS} = V_{IL}$ constantly loads the address on the rising edge of the CLK; numbers are for reference use only.
4. "NOP" is "No Operation." Data in memory at the selected address may be corrupted and should be re-written to guarantee data integrity.

Timing Waveform of Pipelined Read with Address Counter Advance ⁽¹⁾

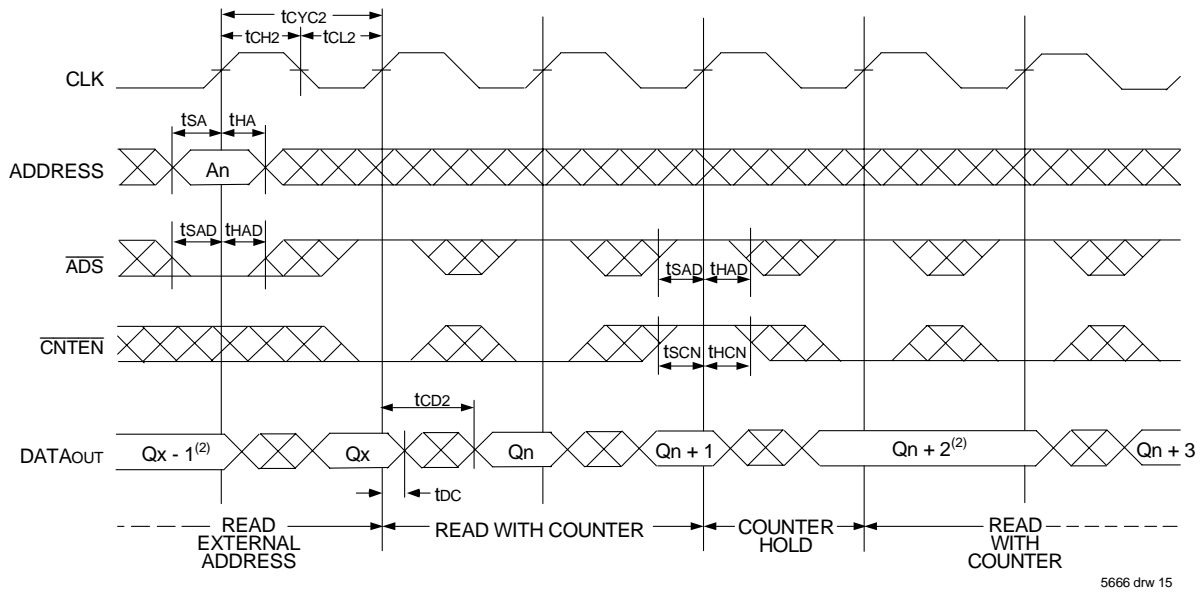

Timing Waveform of Flow-Through Read with Address Counter Advance ⁽¹⁾

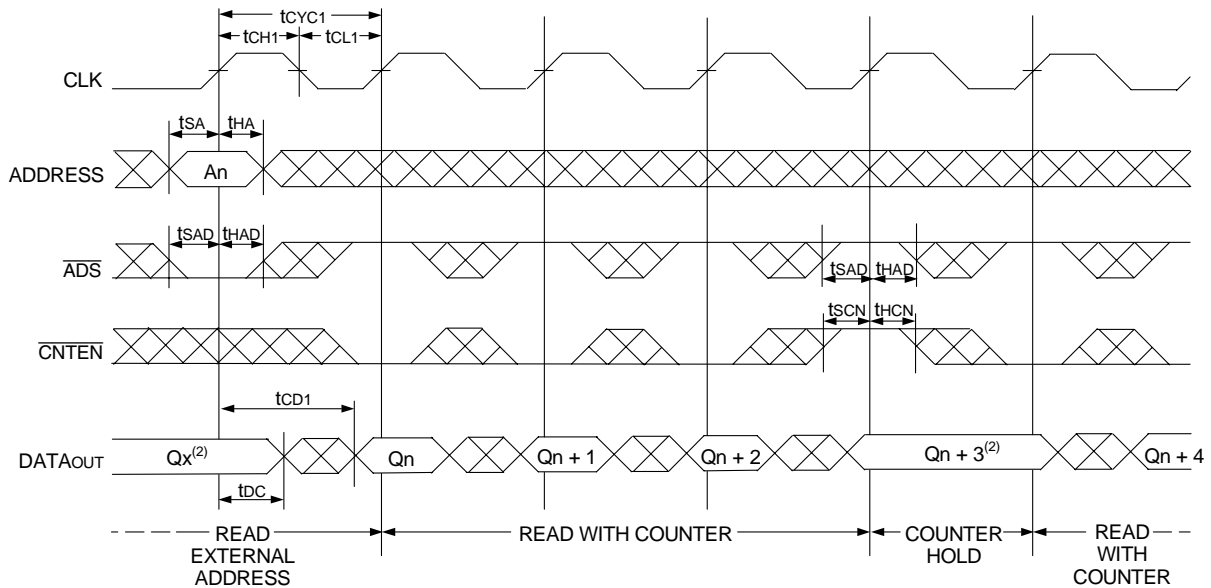

NOTES:

1. \overline{CE}_0 , \overline{OE} , $\overline{BE}_n = V_{IL}$; \overline{CE}_1 , R/\overline{W} , and $\overline{REPEAT} = V_{IH}$.
2. If there is no address change via $\overline{ADS} = V_{IL}$ (loading a new address) or $\overline{CNTEN} = V_{IL}$ (advancing the address), i.e. $\overline{ADS} = V_{IH}$ and $\overline{CNTEN} = V_{IH}$, then the data output remains constant for subsequent clocks.

Timing Waveform of Write with Address Counter Advance (Flow-through or Pipelined Inputs) (1)

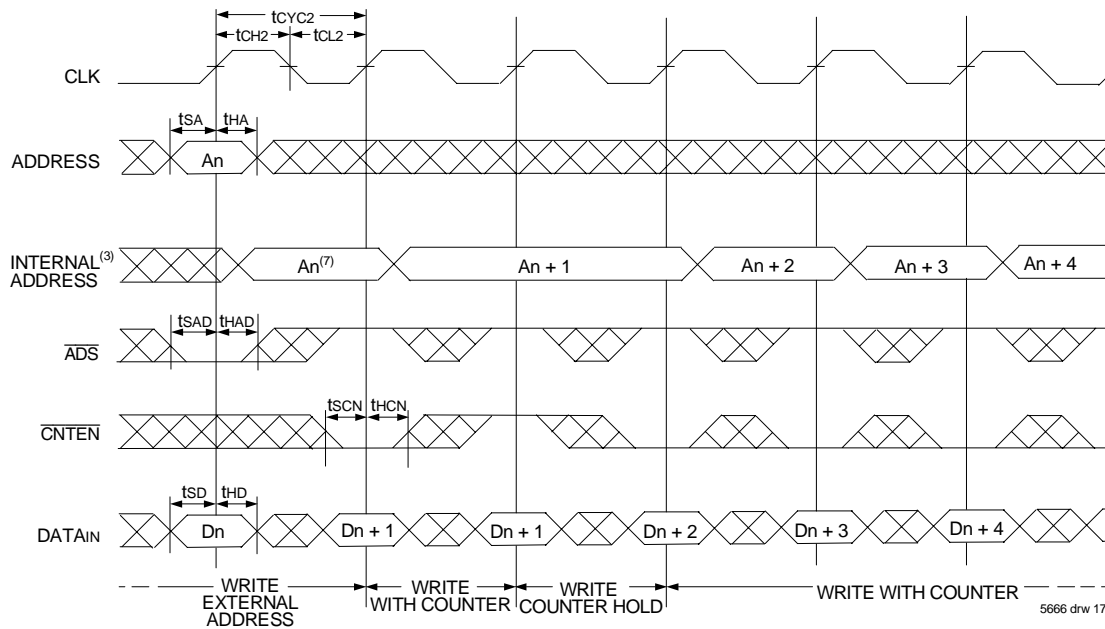

5666 drw 17

Timing Waveform of Counter Repeat (2,6)

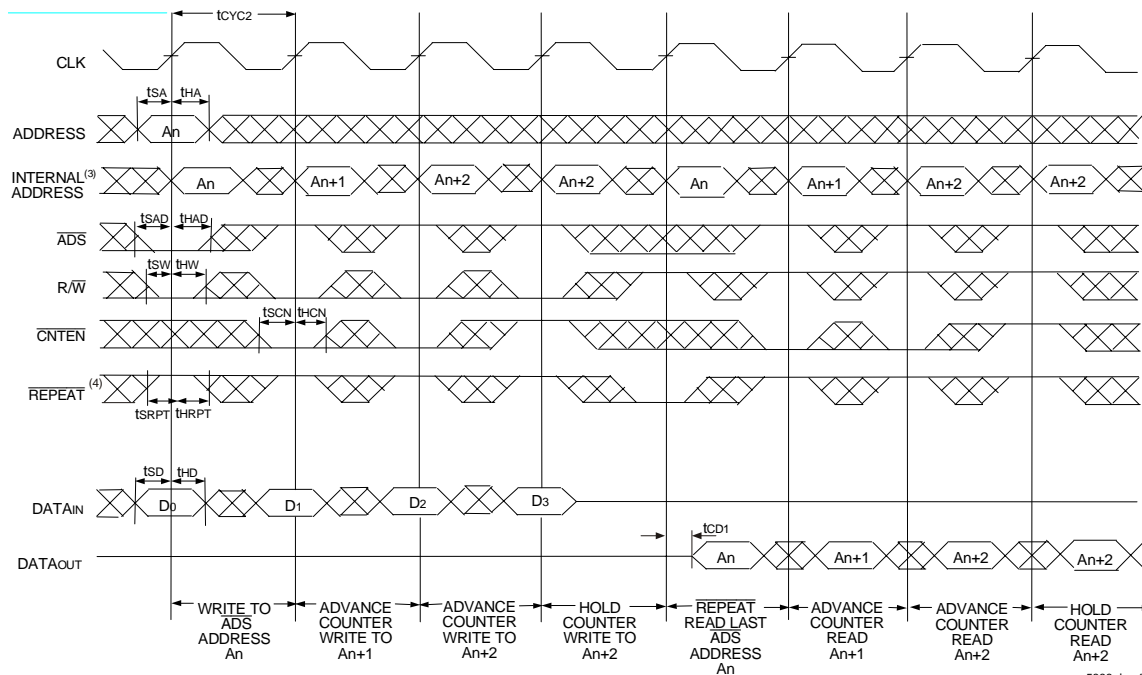

5666 drw 18

NOTES:

1. \overline{CE}_0 , \overline{BE}_n , and $R/\overline{W} = V_{IL}$; CE_1 and $\overline{REPEAT} = V_{IH}$.
2. \overline{CE}_0 , $\overline{BE}_n = V_{IL}$; $CE_1 = V_{IH}$.
3. The "Internal Address" is equal to the "External Address" when $\overline{ADS} = V_{IL}$ and equals the counter output when $\overline{ADS} = V_{IH}$.
4. No dead cycle exists during REPEAT operation. A READ or WRITE cycle may be coincidental with the counter REPEAT cycle: Address loaded by last valid \overline{ADS} load will be accessed. For more information on REPEAT function refer to Truth Table II.
5. $\overline{CNTEN} = V_{IL}$ advances Internal Address from 'An' to 'An +1'. The transition shown indicates the time required for the counter to advance. The 'An +1' Address is written to during this cycle.
6. For Pipelined Mode user should add 1 cycle latency for outputs as per timing waveform of read cycle for pipelined operations.

Waveform of Interrupt Timing (2)

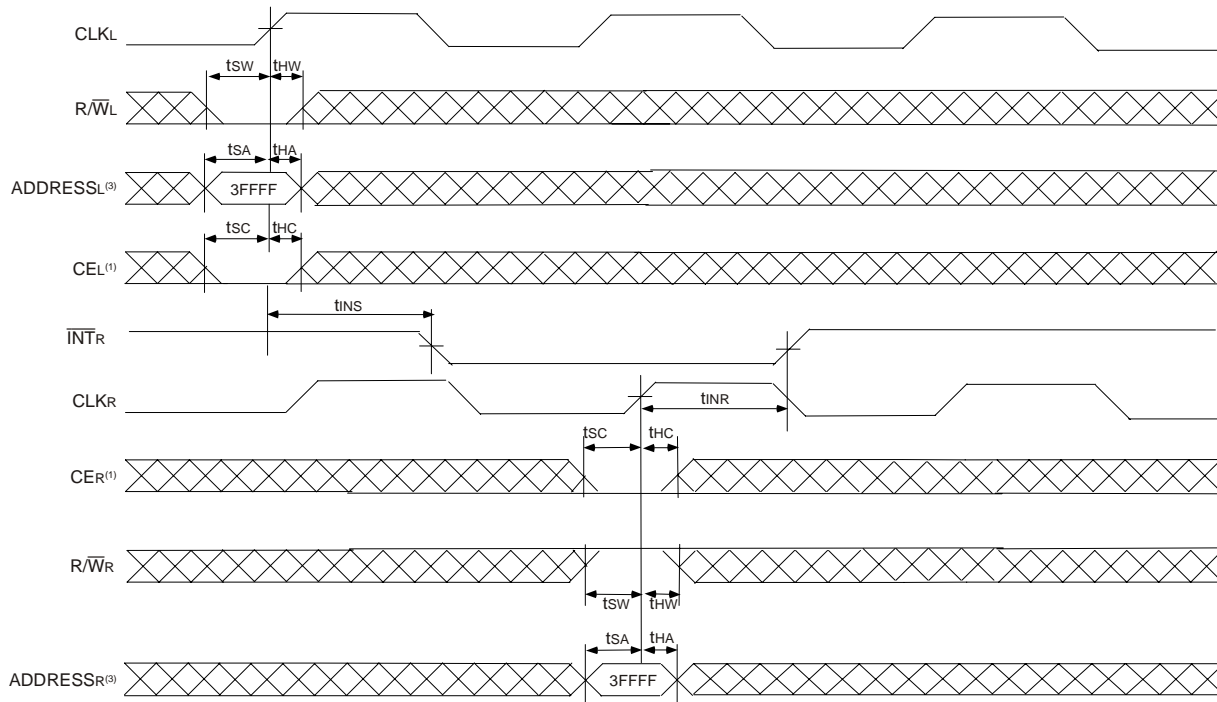

NOTES:

1. CE0 = VIL and CE1 = VIH
2. All timing is the same for Left and Right ports.
3. Address is for internal register, not the external bus, i.e., address needs to be qualified by one of the Address counter control signals.

5666 drw 19

Truth Table III — Interrupt Flag (1)

Left Port					Right Port					Function
CLKL	R/WL ⁽²⁾	CEL ⁽²⁾	A17L-A0L ^(3,4,5)	INTL	CLKR	R/WR ⁽²⁾	CER ⁽²⁾	A17R-A0R ^(3,4,5)	INTR	
↑	L	L	3FFFF	X	↑	X	X	X	L	Set Right INTR Flag
↑	X	X	X	X	↑	H	L	3FFFF	H	Reset Right INTR Flag
↑	X	X	X	L	↑	L	L	3FFFE	X	Set Left INTL Flag
↑	H	L	3FFFE	H	↑	X	X	X	X	Reset Left INTL Flag

NOTES:

1. INTL and INTR must be initialized at power-up by Resetting the flags.
2. CE0 = VIL and CE1 = VIH. R/W and CE are synchronous with respect to the clock and need valid set-up and hold times.
3. A17x is a NC for IDT70T3599, therefore Interrupt Addresses are 1FFFF and 1FFFE.
4. A17x and A16x are NC's for IDT70T3589, therefore Interrupt Addresses are FFFF and FFFE.
5. Address is for internal register, not the external bus, i.e., address needs to be qualified by one of the Address counter control signals.

5666 tbl 12

Waveform of Collision Timing^(1,2) Both Ports Writing with Left Port Clock Leading

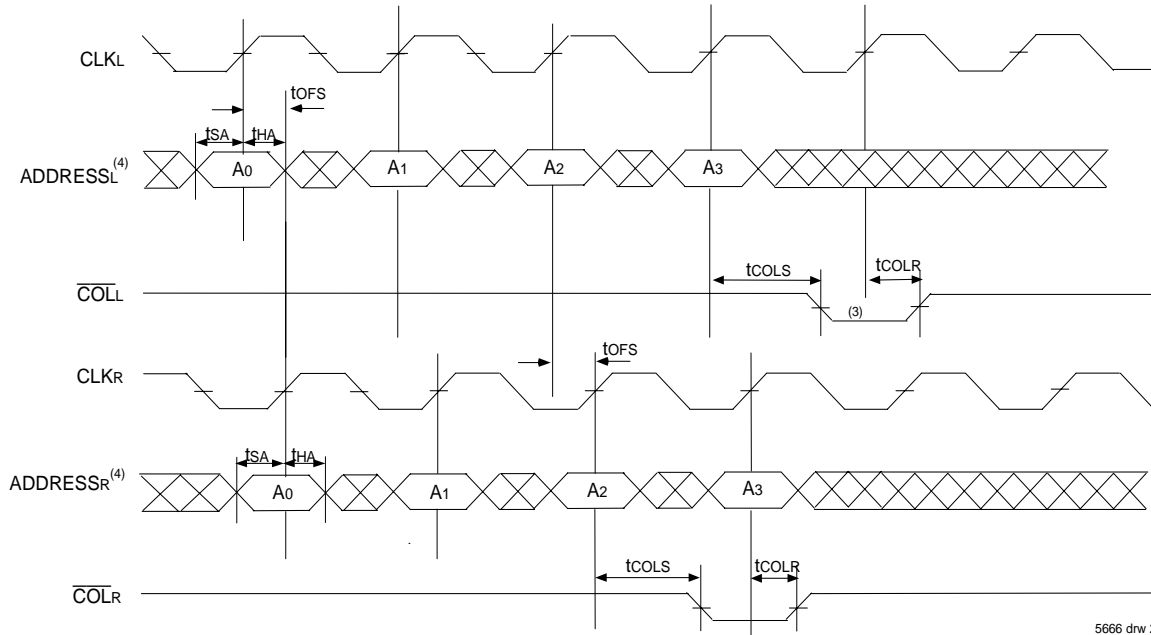

NOTES:

1. $\overline{CE}_0 = V_{IL}$, $CE_1 = V_{IH}$.
2. For reading port, \overline{OE} is a Don't care on the Collision Detection Logic. Please refer to Truth Table IV for specific cases.
3. Leading Port Output flag might output $3t_{OFS} + t_{COLS}$ after Address match.
4. Address is for internal register, not the external bus, i.e., address needs to be qualified by one of the Address counter control signals.

5666 drw 20

Collision Detection Timing^(3,4)

Cycle Time	t _{OFS} (ns)	
	Region 1 (ns) ⁽¹⁾	Region 2 (ns) ⁽²⁾
5ns	0 - 2.8	2.81 - 4.6
6ns	0 - 3.8	3.81 - 5.6
7.5ns	0 - 5.3	5.31 - 7.1

5666 tbl 13

NOTES:

1. **Region 1**
Both ports show collision after 2nd cycle for Addresses 0, 2, 4 etc.
2. **Region 2**
Leading port shows collision after 3rd cycle for addresses 0, 3, 6, etc. while trailing port shows collision after 2nd cycle for addresses 0, 2, 4 etc.
3. All the production units are tested to midpoint of each region.
4. These ranges are based on characterization of a typical device.

Truth Table IV — Collision Detection Flag

Left Port					Right Port					Function
CLKL	R \overline{W} L ⁽¹⁾	CE ₁ ⁽¹⁾	A _{17L} -A _{0L} ⁽²⁾	\overline{COLL}	CLKR	R \overline{W} R ⁽¹⁾	CE ₁ ⁽¹⁾	A _{17R} -A _{0R} ⁽²⁾	\overline{COLR}	
↑	H	L	MATCH	H	↑	H	L	MATCH	H	Both ports reading. Not a valid collision. No flag output on either port.
↑	H	L	MATCH	L	↑	L	L	MATCH	H	Left port reading, Right port writing. Valid collision, flag output on Left port.
↑	L	L	MATCH	H	↑	H	L	MATCH	L	Right port reading, Left port writing. Valid collision, flag output on Right port.
↑	L	L	MATCH	L	↑	L	L	MATCH	L	Both ports writing. Valid collision. Flag output on both ports.

NOTES:

1. $\overline{CE}_0 = V_{IL}$ and $CE_1 = V_{IH}$. R \overline{W} and CE are synchronous with respect to the clock and need valid set-up and hold times.
2. Address is for internal register, not the external bus, i.e., address needs to be qualified by one of the Address counter control signals.

5666 tbl 14

Timing Waveform - Entering Sleep Mode (1,2)

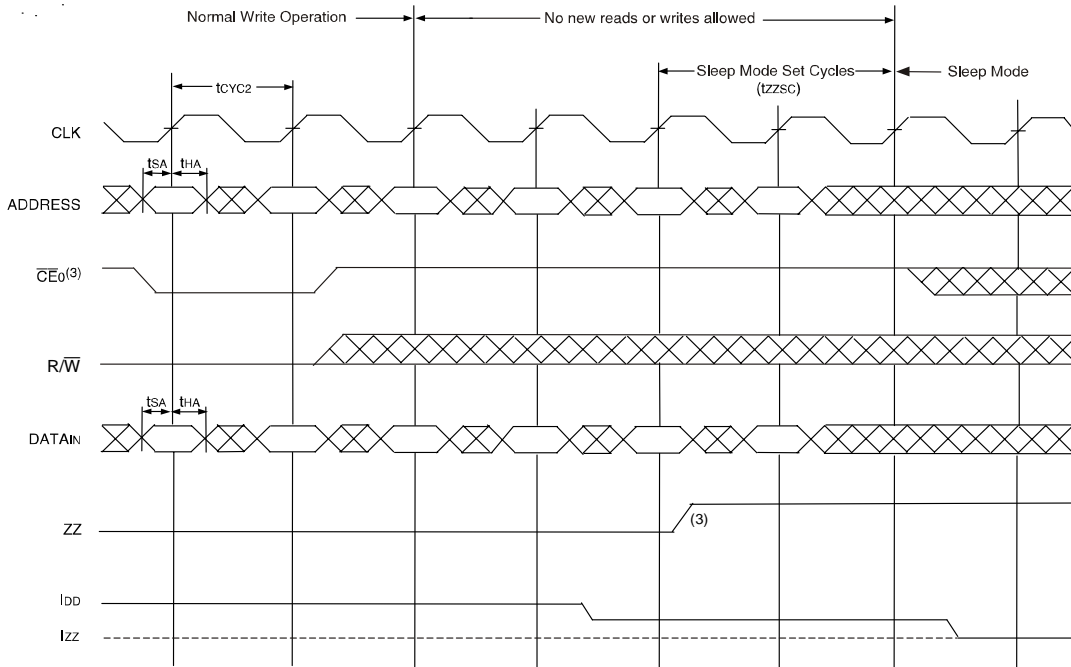

5666 drw 22

Timing Waveform - Exiting Sleep Mode (1,2)

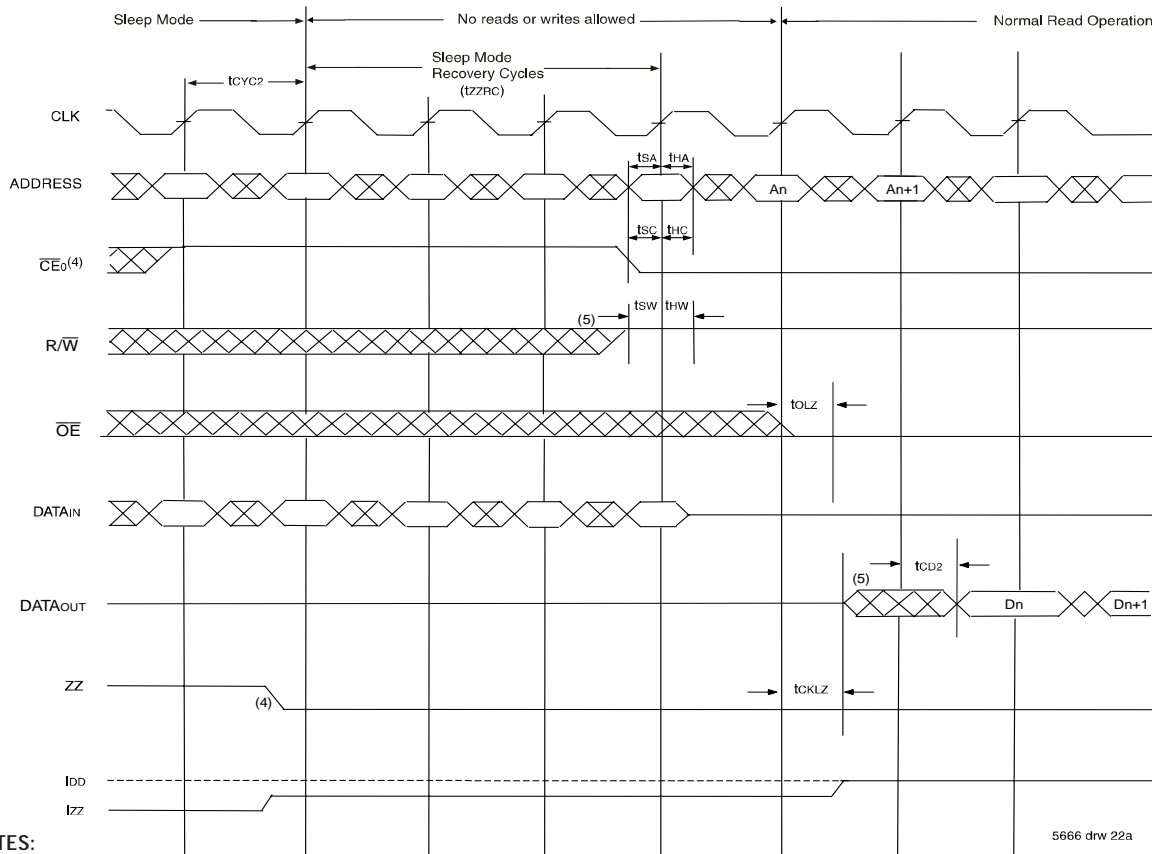

5666 drw 22a

NOTES:

1. $CE_1 = V_{IH}$.
2. All timing is same for Left and Right ports.
3. \overline{CE}_0 has to be deactivated ($\overline{CE}_0 = V_{IH}$) three cycles prior to asserting ZZ ($ZZx = V_{IH}$) and held for two cycles after asserting ZZ ($ZZx = V_{IH}$).
4. \overline{CE}_0 has to be deactivated ($\overline{CE}_0 = V_{IH}$) one cycle prior to de-asserting ZZ ($ZZx = V_{IL}$) and held for three cycles after de-asserting ZZ ($ZZx = V_{IL}$).
5. The device must be in Read Mode (R/W High) when exiting sleep mode. Outputs are active but data is not valid until the following cycle.

Functional Description

The IDT70T3519/99/89 provides a true synchronous Dual-Port Static RAM interface. Registered inputs provide minimal set-up and hold times on address, data, and all critical control inputs. All internal registers are clocked on the rising edge of the clock signal, however, the self-timed internal write pulse width is independent of the cycle time.

An asynchronous output enable is provided to ease asynchronous bus interfacing. Counter enable inputs are also provided to stall the operation of the address counters for fast interleaved memory applications.

A HIGH on $\overline{CE_0}$ or a LOW on CE_1 for one clock cycle will power down the internal circuitry to reduce static power consumption. Multiple chip enables allow easier banking of multiple IDT70T3519/99/89s for depth expansion configurations. Two cycles are required with $\overline{CE_0}$ LOW and CE_1 HIGH to re-activate the outputs.

Interrupts

If the user chooses the interrupt function, a memory location (mail box or message center) is assigned to each port. The left port interrupt flag ($\overline{INT_L}$) is asserted when the right port writes to memory location 3FFFE (HEX), where a write is defined as $\overline{CE_R} = R/\overline{W_R} = V_{IL}$ per the Truth Table. The left port clears the interrupt through access of address location 3FFFE when $\overline{CE_L} = V_{IL}$ and $R/\overline{W_L} = V_{IH}$. Likewise, the right port interrupt flag ($\overline{INT_R}$) is asserted when the left port writes to memory location 3FFFF (HEX) and to clear the interrupt flag ($\overline{INT_R}$), the right port must read the memory location 3FFFF (1FFFF or 1FFFE for IDT70T3599 and FFFF or FFFE for IDT70T3589). The message (36 bits) at 3FFFE or 3FFFF (1FFFF or 1FFFE for IDT70T3599 and FFFF or FFFE for IDT70T3589) is user-defined since it is an addressable SRAM location. If the interrupt function is not used, address locations 3FFFE and 3FFFF (1FFFF or 1FFFE for IDT70T3599 and FFFF or FFFE for IDT70T3589) are not used as mail boxes, but as part of the random access memory. Refer to Truth Table III for the interrupt operation.

Collision Detection

Collision is defined as an overlap in access between the two ports resulting in the potential for either reading or writing incorrect data to a specific address. For the specific cases: (a) Both ports reading - no data is corrupted, lost, or incorrectly output, so no collision flag is output on either port. (b) One port writing, the other port reading - the end result of the write will still be valid. However, the reading port might capture data that is in a state of transition and hence the reading port's collision flag is output. (c) Both ports writing - there is a risk that the two ports will interfere with each other, and the data stored in memory will not be a valid write from either port (it may essentially be a random combination of the two). Therefore, the collision flag is output on both ports. Please refer to Truth Table IV for all of the above cases.

The alert flag ($\overline{COL_x}$) is asserted on the 2nd or 3rd rising clock edge of the affected port following the collision, and remains low for one cycle. Please refer to Collision Detection Timing table on Page 21. During that next cycle, the internal arbitration is engaged in resetting the alert flag (this avoids a specific requirement on the part of the user to reset the alert flag). If two collisions occur on subsequent clock cycles, the second collision may not generate the appropriate alert

flag. A third collision will generate the alert flag as appropriate. In the event that a user initiates a burst access on both ports with the same starting address on both ports and one or both ports writing during each access (i.e., imposes a long string of collisions on contiguous clock cycles), the alert flag will be asserted and cleared every other cycle. Please refer to the Collision Detection timing waveform on Page 21.

Collision detection on the IDT70T3519/99/89 represents a significant advance in functionality over current sync multi-ports, which have no such capability. In addition to this functionality the IDT70T3519/99/89 sustains the key features of bandwidth and flexibility. The collision detection function is very useful in the case of bursting data, or a string of accesses made to sequential addresses, in that it indicates a problem within the burst, giving the user the option of either repeating the burst or continuing to watch the alert flag to see whether the number of collisions increases above an acceptable threshold value. Offering this function on chip also allows users to reduce their need for arbitration circuits, typically done in CPLD's or FPGA's. This reduces board space and design complexity, and gives the user more flexibility in developing a solution.

Sleep Mode

The IDT70T3519/99/89 is equipped with an optional sleep or low power mode on both ports. The sleep mode pin on both ports is asynchronous and active high. During normal operation, the ZZ pin is pulled low. When ZZ is pulled high, the port will enter sleep mode where it will meet lowest possible power conditions. The sleep mode timing diagram shows the modes of operation: Normal Operation, No Read/Write Allowed and Sleep Mode.

For normal operation all inputs must meet setup and hold times prior to sleep and after recovering from sleep. Clocks must also meet cycle high and low times during these periods. Three cycles prior to asserting ZZ ($ZZx = V_{IH}$) and three cycles after de-asserting ZZ ($ZZx = V_{IL}$), the device must be disabled via the chip enable pins. If a write or read operation occurs during these periods, the memory array may be corrupted. Validity of data out from the RAM cannot be guaranteed immediately after ZZ is asserted (prior to being in sleep). When exiting sleep mode, the device must be in Read mode ($R/\overline{W}_x = V_{IH}$) when chip enable is asserted, and the chip enable must be valid for one full cycle before a read will result in the output of valid data.

During sleep mode the RAM automatically deselects itself. The RAM disconnects its internal clock buffer. The external clock may continue to run without impacting the RAM's sleep current (I_{ZZ}). All outputs will remain in high-Z state while in sleep mode. All inputs are allowed to toggle. The RAM will not be selected and will not perform any reads or writes.

Depth and Width Expansion

The IDT70T3519/99/89 features dual chip enables (refer to Truth Table I) in order to facilitate rapid and simple depth expansion with no requirements for external logic. Figure 4 illustrates how to control the various chip enables in order to expand two devices in depth.

The IDT70T3519/99/89 can also be used in applications requiring expanded width, as indicated in Figure 4. Through combining the control signals, the devices can be grouped as necessary to accommodate applications needing 72-bits or wider.

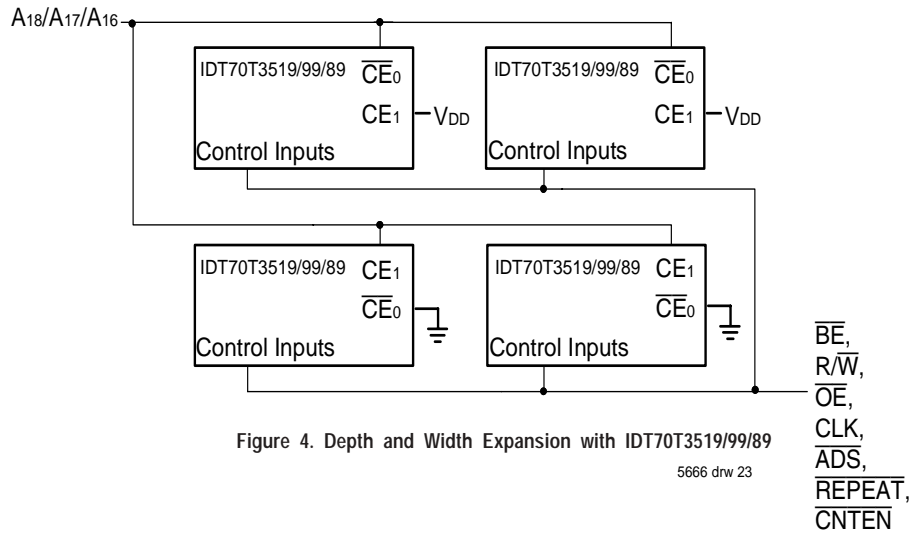

NOTE:

1. A18 is for IDT70T3519, A17 is for IDT70T3599, A16 is for IDT70T3589.

JTAG Timing Specifications

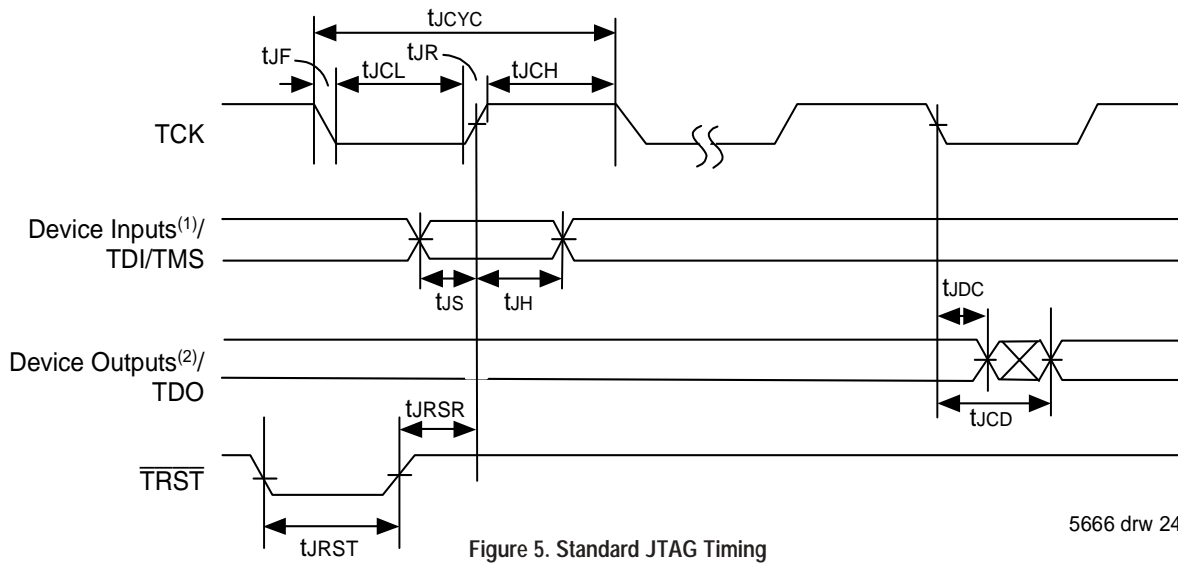

Figure 5. Standard JTAG Timing

5666 drw 24

NOTES:

1. Device inputs = All device inputs except TDI, TMS, and TRST.
2. Device outputs = All device outputs except TDO.

JTAG AC Electrical Characteristics ^(1,2,3,4)

Symbol	Parameter	70T3519/99/89		
		Min.	Max.	Units
t_{JCYC}	JTAG Clock Input Period	100	—	ns
t_{JCH}	JTAG Clock HIGH	40	—	ns
t_{JCL}	JTAG Clock Low	40	—	ns
t_{JR}	JTAG Clock Rise Time	—	3 ⁽¹⁾	ns
t_{JF}	JTAG Clock Fall Time	—	3 ⁽¹⁾	ns
t_{JRST}	JTAG Reset	50	—	ns
t_{JRSR}	JTAG Reset Recovery	50	—	ns
t_{JCD}	JTAG Data Output	—	25	ns
t_{JDC}	JTAG Data Output Hold	0	—	ns
t_{JS}	JTAG Setup	15	—	ns
t_{JH}	JTAG Hold	15	—	ns

5666 tbl 15

NOTES:

1. Guaranteed by design.
2. 30pF loading on external output signals.
3. Refer to AC Electrical Test Conditions stated earlier in this document.
4. JTAG operations occur at one speed (10MHz). The base device may run at any speed specified in this datasheet.

Identification Register Definitions

Instruction Field	Value	Description
Revision Number (31:28)	0x0	Reserved for version number
IDT Device ID (27:12)	0x330 ⁽¹⁾	Defines IDT part number
IDT JEDEC ID (11:1)	0x33	Allows unique identification of device vendor as IDT
ID Register Indicator Bit (Bit 0)	1	Indicates the presence of an ID register

5666 tbl 16

NOTE:

1. Device ID for IDT70T3599 is 0x331. Device ID for IDT70T3589 is 0x332.

Scan Register Sizes

Register Name	Bit Size
Instruction (IR)	4
Bypass (BYR)	1
Identification (IDR)	32
Boundary Scan (BSR)	Note (3)

5666 tbl 17

System Interface Parameters

Instruction	Code	Description
EXTEST	0000	Forces contents of the boundary scan cells onto the device outputs ⁽¹⁾ . Places the boundary scan register (BSR) between TDI and TDO.
BYPASS	1111	Places the bypass register (BYR) between TDI and TDO.
IDCODE	0010	Loads the ID register (IDR) with the vendor ID code and places the register between TDI and TDO.
HIGHZ	0100	Places the bypass register (BYR) between TDI and TDO. Forces all device output drivers to a High-Z state except $\overline{\text{COL}}_x$ & $\overline{\text{INT}}_x$ outputs.
CLAMP	0011	Uses BYR. Forces contents of the boundary scan cells onto the device outputs. Places the bypass register (BYR) between TDI and TDO.
SAMPLE/PRELOAD	0001	Places the boundary scan register (BSR) between TDI and TDO. SAMPLE allows data from device inputs ⁽²⁾ to be captured in the boundary scan cells and shifted serially through TDO. PRELOAD allows data to be input serially into the boundary scan cells via the TDI.
RESERVED	0101, 0111, 1000, 1001, 1010, 1011, 1100	Several combinations are reserved. Do not use codes other than those identified above.
PRIVATE	0110, 1110, 1101	For internal use only.

5666 tbl 18

NOTES:

1. Device outputs = All device outputs except TDO.
2. Device inputs = All device inputs except TDI, TMS, and $\overline{\text{TRST}}$.
3. The Boundary Scan Descriptive Language (BSDL) file for this device is available on the IDT website (www.idt.com), or by contacting your local IDT sales representative.

Ordering Information

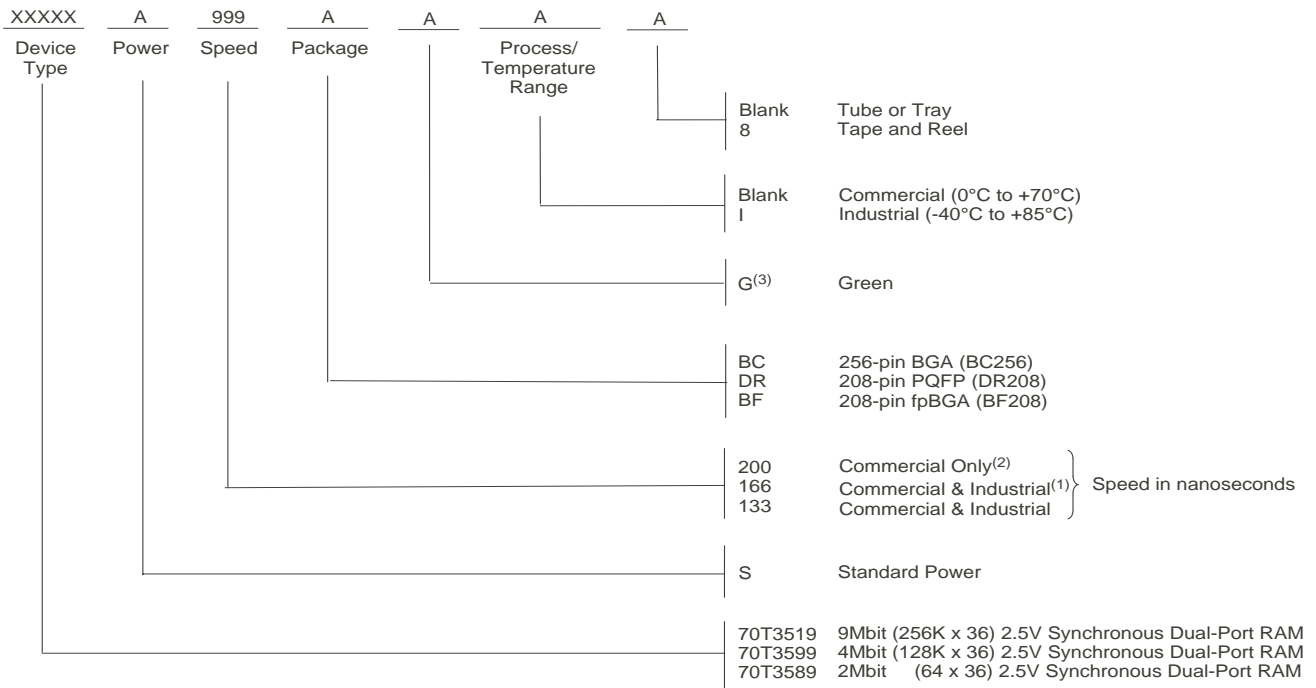

5666 drw 25

NOTES:

- 166MHz I-Temp is only available in the BC256 package.
- 200MHz is only available in the BC256 package.
- Green parts available. For specific speeds, packages and powers contact your local sales office.
LEAD FINISH (SnPb) parts are in EOL process. Product Discontinuation Notice - PDN# SP-17-02

IDT Clock Solution for IDT70T3519/99/89 Dual-Port

IDT Dual-Port Part Number	Dual-Port I/O Specifications		Clock Specifications				IDT PLL Clock Device	IDT Non-PLL Clock Device
	Voltage	I/O	Input Capacitance	Input Duty Cycle Requirement	Maximum Frequency	Jitter Tolerance		
70T3519/99/89	2.5	LVTTTL	8pF	40%	200	75ps	5T2010	5T905, 5T9050 5T907, 5T9070

5666 tbl 19

Datasheet Document History:

01/23/03:		Initial Datasheet
01/30/03:	Page 1	Corrected 208-pin package from TQFP to PQFP
04/25/03:	Page 11	Added Capacitance Derating drawing
	Page 12	Changed t_{INS} and t_{INR} specs in AC Electrical Characteristics table
11/11/03:	Page 10	Updated power numbers in DC Electrical Characteristics table
	Page 12	Added t_{FS} symbol and parameter to AC Electrical Characteristics table
	Page 21	Updated Collision Timing waveform
	Page 22	Added Collision Detection Timing table and footnotes
	Page 26	Updated HIGHZ function in System Interface Parameters table
	Page 27	Added IDT Clock Solution table
03/30/04:	Page 22 & 23	Clarified Sleep Mode Text and Waveforms
	Page 1 & 27	Removed Preliminary status
04/22/04:	Page 6	Added another sentence to footnote 4 to recommend that boundary scan not be operated during sleep mode
04/12/05:	Page 27	Clarified footnotes 1 & 2 for the ordering information
	Page 1 & 28	Replaced old IDT TM with new IDT TM logo
	Page 1	Added green availability to features
	Page 27	Added green indicator to ordering information
02/07/06:	Page 7	Changed footnote 2 for Truth Table I from $\overline{ADS}, \overline{CNTEN}, \overline{REPEAT} = V_{IH}$ to $\overline{ADS}, \overline{CNTEN}, \overline{REPEAT} = X$
04/10/06:	Page 1, 3 & 12	Changed \overline{FTx}/PLx to PLx/\overline{FTx} on diagrams and Notes.
07/28/08:	Page 10	Corrected a typo in the footnotes of DC Chars table
01/19/09:	Page 27	Removed "IDT" from orderable part number
03/19/14:	Page 3, 4 & 5	Removed the footnote that referenced the future use of HSTL for each of the Pin configurations
	Page 3 & 27	The label BC-256 changed to BC256 in the Pin configuration, throughout the datasheet and in the Ordering Information to accurately match the standard package code
	Page 4 & 27	The label DR-208 changed to DR208 in the Pin configuration, throughout the datasheet and in the Ordering Information to accurately match the standard package code
	Page 5 & 27	The label BF-208 changed to BF208 in the Pin configuration, throughout the datasheet and in the Ordering Information to accurately match the standard package code
	Page 27	Added Tape & Reel indicator to Ordering Information
	Page 27	Removed obsolete clock device 5T9010 from the Clock Solution table
06/19/18:		Product Discontinuation Notice - PDN# SP-17-02 Last time buy expires June 15, 2018



CORPORATE HEADQUARTERS
6024 Silver Creek Valley Road
San Jose, CA 95138

for SALES:
800-345-7015 or 408-284-8200
fax: 408-284-2775
www.idt.com

for Tech Support:
408-284-2794
DualPortHelp@idt.com

The IDT logo is a registered trademark of Integrated Device Technology, Inc.

Looking for pricing, stock, or lifecycle information?

Click below to explore more details on WIN SOURCE:

-  [View 70T3589S133BC8 on WIN SOURCE](#)
-  [IDT, Integrated Device Technology Inc Information](#)

Optimize Your Supply Chain with WIN SOURCE Solutions

-  Global Sourcing Solution
-  Obsolete Management
-  Cost Control Management
-  Shortage Management
-  Alternative Solution
-  Excess Inventory Management