



**THE DATASHEET OF  
S29AS016J70BHIF40**



# 16 Mbit (2 M x 8-Bit/1 M x 16-Bit), 1.8 V Boot Sector Flash

## Distinctive Characteristics

### Architectural Advantages

- Single Power Supply Operation
  - Full voltage range: 1.65 to 1.95 volt read and write operations for battery-powered applications
- Manufactured on 110 nm Process Technology
  - Backward compatible with 0.32 μm Am29SL160C device
- Secured Silicon Sector region
  - 128-word/256-byte sector for permanent, secure identification through an 8-word/16-byte random Electronic Serial Number, accessible through a command sequence
  - May be programmed and locked at the factory or by the customer
- Flexible Sector Architecture
  - Eight 8 Kbyte and thirty-one 64 Kbyte sectors (byte mode)
  - Eight 4 Kword, and thirty-one 32 Kword sectors (word mode)
- Sector Group Protection Features
  - A hardware method of locking a sector to prevent any program or erase operations within that sector
  - Sectors can be locked in-system or via programming equipment
  - Temporary Sector Group Unprotect feature allows code changes in previously locked sectors
- Unlock Bypass Program Command
  - Reduces overall programming time when issuing multiple program command sequences
- Top or Bottom Boot Block Configurations Available
- Compatibility with JEDEC standards
  - Pinout and software compatible with single-power supply Flash
  - Superior inadvertent write protection

### Performance Characteristics

- High Performance
  - Access times as fast as 70 ns
  - Industrial temperature range (-40 °C to +85 °C)
  - Industrial Plus temperature range (-40 °C to +105 °C)
  - Automotive, AEC-Q100 Grade 3 (-40 °C to +85 °C)
  - Automotive, AEC-Q100 Grade 2 (-40 °C to +105 °C)
  - Word programming time as fast as 6 μs (typical)
- Ultra Low Power Consumption (typical values at 5 MHz)
  - 15 μA Automatic Sleep mode current
  - 8 μA standby mode current
  - 8 mA read current
  - 20 mA program/erase current
- Cycling Endurance: 1,000,000 cycles per sector typical
- Data Retention: 20 years typical

### Package Options

- 48-ball Fine-Pitch BGA, 8.15 mm x 6.15 mm
- 48-ball Fine-Pitch BGA, 6.0 mm x 4.0 mm
- 48-pin TSOP

### Software Features

- CFI (Common Flash Interface) Compliant
  - Provides device-specific information to the system, allowing host software to easily reconfigure for different Flash devices
- Erase Suspend/Erase Resume
  - Suspends an erase operation to read data from, or program data to, a sector that is not being erased, then resumes the erase operation
- Data# Polling and Toggle Bits
  - Provides a software method of detecting program or erase operation completion

### Hardware Features

- Ready/Busy# Pin (RY/BY#)
  - Provides a hardware method of detecting program or erase cycle completion
- Hardware Reset Pin (RESET#)
  - Hardware method to reset the device to reading array data
- WP# Input Pin
  - Write protect (WP#) function allows protection of two outermost boot sectors (boot sector models only), regardless of sector group protect status

## General Description

The S29AS016J is a 16 Mbit, 1.8 Volt-only Flash memory organized as 2,097,152 bytes or 1,048,576 words with a x8/x16 bus and either top or bottom boot sector architecture. The device is offered in 48-pin TSOP and 48-ball FBGA packages. The word-wide data (x16) appears on DQ15–DQ0; the byte-wide (x8) data appears on DQ7–DQ0. This device is designed to be programmed and erased in-system with the standard system 1.8 volt  $V_{CC}$  supply. A 12.0V  $V_{PP}$  or 5.0  $V_{CC}$  are not required for program or erase operations. The device can also be programmed in standard EPROM programmers.

The device offers access time of 70 ns allowing high speed microprocessors to operate without wait states. To eliminate bus contention the device has separate chip enable (CE#), write enable (WE#) and output enable (OE#) controls.

The device requires only a **single 1.8 volt power supply** for both read and write functions. Internally generated and regulated voltages are provided for the program and erase operations.

The S29AS016J is entirely command set compatible with the **JEDEC single-power-supply Flash standard**. Commands are written to the command register using standard microprocessor write timings. Register contents serve as input to an internal state-machine that controls the erase and programming circuitry. Write cycles also internally latch addresses and data needed for the programming and erase operations. Reading data out of the device is similar to reading from other Flash or EPROM devices.

Device programming occurs by executing the program command sequence. This initiates the **Embedded Program** algorithm—an internal algorithm that automatically times the program pulse widths and verifies proper cell margin. The **Unlock Bypass** mode facilitates faster programming times by requiring only two write cycles to program data instead of four.

Device erasure occurs by executing the erase command sequence. This initiates the **Embedded Erase** algorithm—an internal algorithm that automatically preprograms the array (if it is not already programmed) before executing the erase operation. During erase, the device automatically times the erase pulse widths and verifies proper cell margin.

The host system can detect whether a program or erase operation is complete by observing the RY/BY# pin, or by reading the DQ7 (Data# Polling) and DQ6 (toggle) **status bits**. After a program or erase cycle has been completed, the device is ready to read array data or accept another command.

The **sector erase architecture** allows memory sectors to be erased and reprogrammed without affecting the data contents of other sectors. The device is fully erased when shipped from the factory.

**Hardware data protection** measures include a low  $V_{CC}$  detector that automatically inhibits write operations during power transitions. The **hardware sector group protection** feature disables both program and erase operations in any combination of the sectors of memory. This can be achieved in-system or via programming equipment.

The **Erase Suspend/Erase Resume** feature enables the user to put erase on hold for any period of time to read data from, or program data to, any sector that is not selected for erasure. True background erase can thus be achieved.

The **hardware RESET# pin** terminates any operation in progress and resets the internal state machine to reading array data. The RESET# pin may be tied to the system reset circuitry. A system reset would thus also reset the device, enabling the system microprocessor to read the boot-up firmware from the Flash memory.

The device offers two power-saving features. When addresses have been stable for a specified amount of time, the device enters the **automatic sleep mode**. The system can also place the device into the **standby mode**. Power consumption is greatly reduced in both these modes.

Cypress Flash technology combines years of Flash memory manufacturing experience to produce the highest levels of quality, reliability and cost effectiveness. The device electrically erases all bits within a sector simultaneously via Fowler-Nordheim tunneling. The data is programmed using hot electron injection.

## Contents

<b>1. Product Selector Guide</b> .....	4	10.5 Word/Byte Program Command Sequence.....	28
<b>2. Block Diagram</b> .....	4	10.6 Unlock Bypass Command Sequence .....	28
<b>3. Connection Diagrams</b> .....	5	10.7 Chip Erase Command Sequence .....	29
3.1 Standard TSOP.....	5	10.8 Sector Erase Command Sequence .....	30
3.2 FBGA Connection Diagram, 8.15 mm x 6.15 mm (VBK048) .....	6	10.9 Erase Suspend/Erase Resume Commands .....	30
3.3 FBGA Connection Diagram, 6.0 mm x 4.0 mm (VDF048) .....	7	<b>11. Command Definitions</b> .....	32
3.4 Special Handling Instructions.....	7	<b>12. Write Operation Status</b> .....	34
<b>4. Pin Configuration</b> .....	8	12.1 DQ7: Data# Polling .....	34
<b>5. Logic Symbol</b> .....	8	12.2 RY/BY#: Ready/Busy#.....	35
<b>6. Ordering Information</b> .....	9	12.3 DQ6: Toggle Bit I .....	36
6.1 S29AS016J Standard Products .....	9	12.4 DQ2: Toggle Bit II .....	36
<b>7. Device Bus Operations</b> .....	11	12.5 Reading Toggle Bits DQ6/DQ2.....	36
7.1 Word/Byte Configuration.....	12	12.6 DQ5: Exceeded Timing Limits .....	37
7.2 Requirements for Reading Array Data.....	12	12.7 DQ3: Sector Erase Timer.....	38
7.3 Writing Commands/Command Sequences.....	12	<b>13. Absolute Maximum Ratings</b> .....	39
7.4 Program and Erase Operation Status.....	12	<b>14. Operating Ranges</b> .....	39
7.5 Standby Mode.....	13	<b>15. DC Characteristics</b> .....	40
7.6 Automatic Sleep Mode.....	13	15.1 CMOS Compatible.....	40
7.7 RESET#: Hardware Reset Pin.....	13	<b>16. Test Conditions</b> .....	41
7.8 Output Disable Mode .....	13	<b>17. Key to Switching Waveforms</b> .....	41
7.9 Autoselect Mode .....	14	<b>18. AC Characteristics</b> .....	42
7.10 Sector Address Tables.....	15	18.1 Read Operations.....	42
7.11 Sector Group Protection/Unprotection .....	17	18.2 Hardware Reset (RESET#).....	43
7.12 Temporary Sector Group Unprotect.....	20	18.3 Word/Byte Configuration (BYTE#).....	44
7.13 Write Protect (WP#).....	20	18.4 Erase/Program Operations .....	45
7.14 Hardware Data Protection.....	20	18.5 Temporary Sector Group Unprotect.....	48
<b>8. Secured Silicon Sector Flash Memory Region</b> .....	22	18.6 Alternate CE# Controlled Erase/Program Operations .....	49
8.1 Factory Locked: Secured Silicon Sector Programmed and Protected at the Factory .....	22	<b>19. Erase and Programming Performance</b> .....	51
8.2 Customer Lockable: Secured Silicon Sector NOT Programmed or Protected at the Factory .....	22	<b>20. Package Pin Capacitance</b> .....	51
<b>9. Common Flash Memory Interface (CFI)</b> .....	24	<b>21. Physical Dimensions</b> .....	52
<b>10. Command Definitions</b> .....	27	<b>22. Document History</b> .....	55
10.1 Reading Array Data .....	27	<b>Sales, Solutions, and Legal Information</b> .....	57
10.2 Reset Command.....	27	Worldwide Sales and Design Support .....	57
10.3 Autoselect Command Sequence .....	27	Products .....	57
10.4 Enter Secured Silicon Sector/Exit Secured Silicon Sector Command Sequence .....	28	PSoC® Solutions .....	57
		Cypress Developer Community .....	57
		Technical Support .....	57

## 1. Product Selector Guide

Family Part Number		S29AS016J
Speed Option	Voltage Range: $V_{CC} = 1.65\text{--}1.95\text{ V}$	70
Max access time, ns ( $t_{ACC}$ )		70
Max CE# access time, ns ( $t_{CE}$ )		70
Max OE# access time, ns ( $t_{OE}$ )		25

**Note**

1. See [Section 18. AC Characteristics](#) on page 42 for full specifications.

## 2. Block Diagram

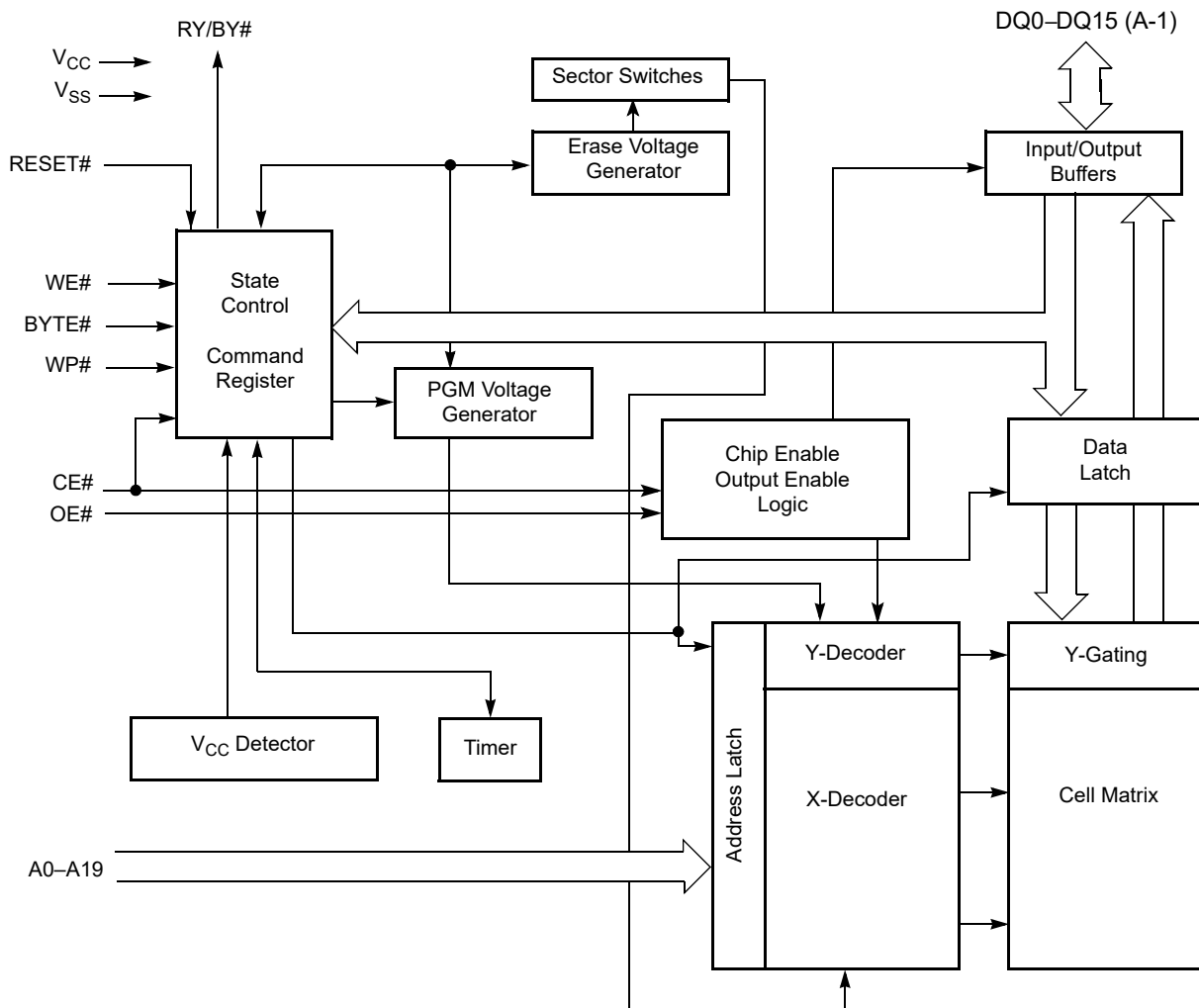

### 3. Connection Diagrams

#### 3.1 Standard TSOP

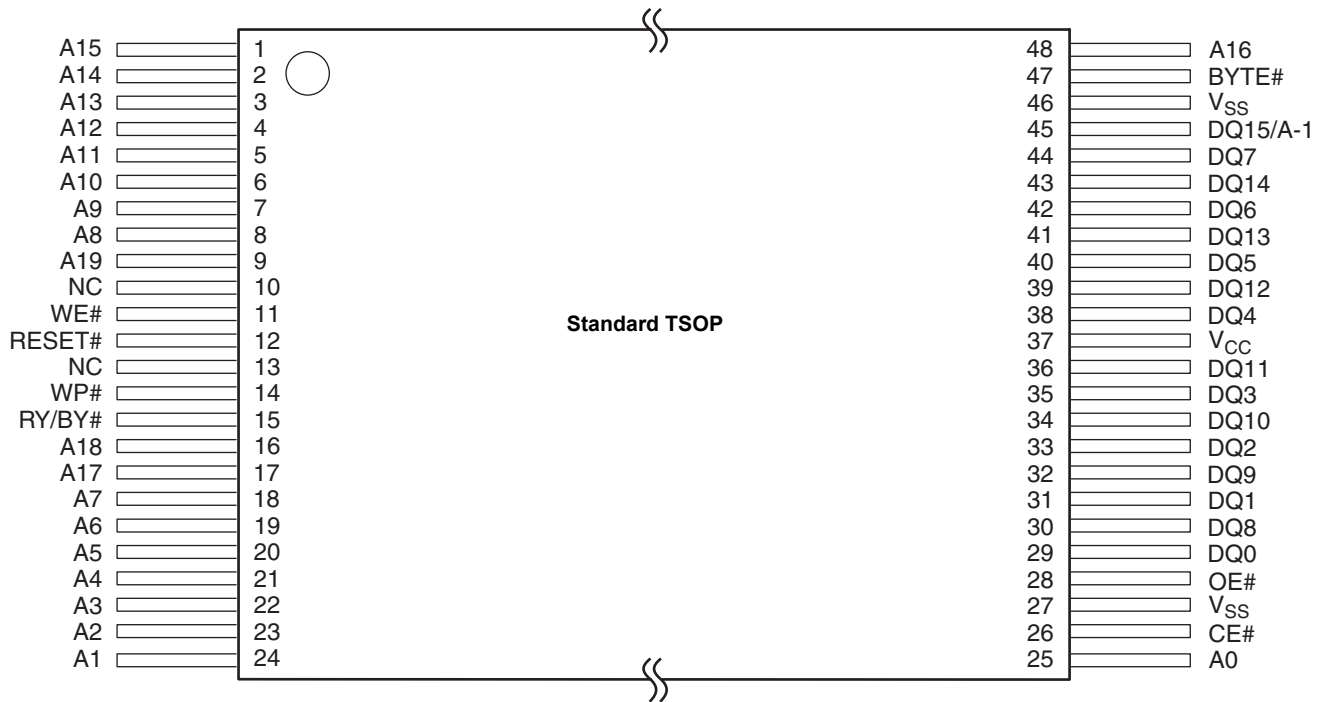

### 3.2 FBGA Connection Diagram, 8.15 mm x 6.15 mm (VBK048)

Fine-pitch Ball Grid Array - VBK048  
Top View, Balls Facing Down

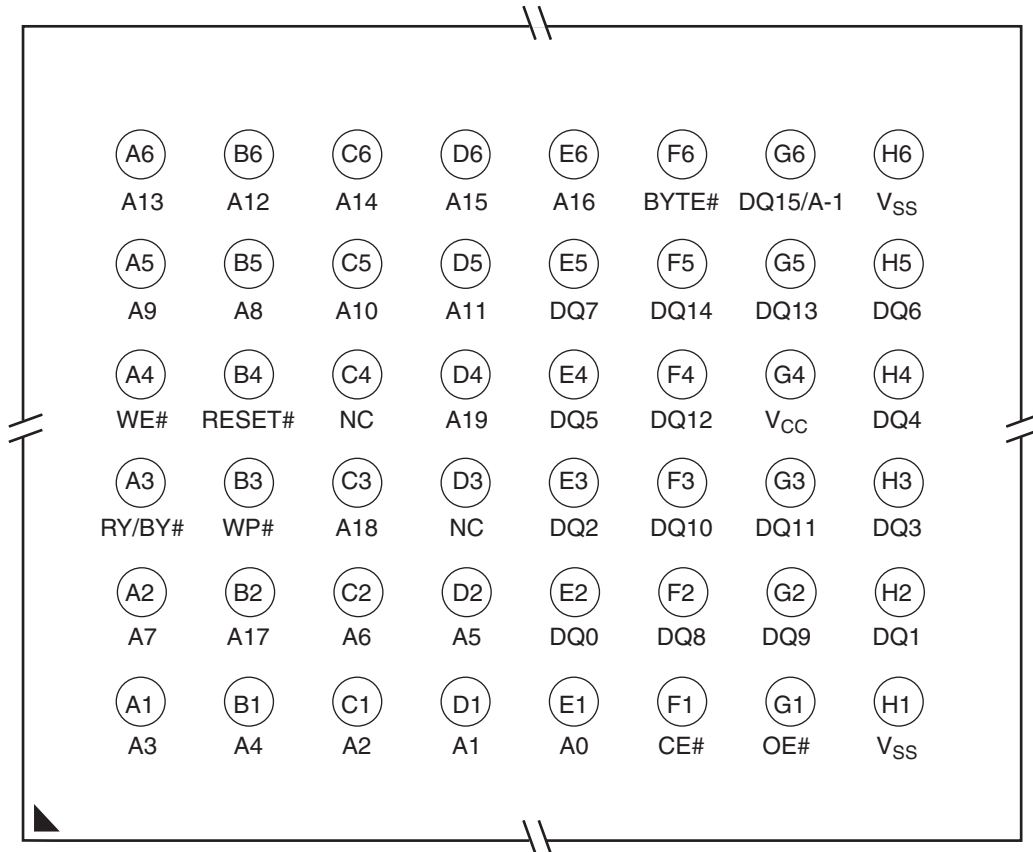

### 3.3 FBGA Connection Diagram, 6.0 mm x 4.0 mm (VDF048)

Fine-pitch Ball Grid Array - VDF048  
Top View, Balls Facing Down

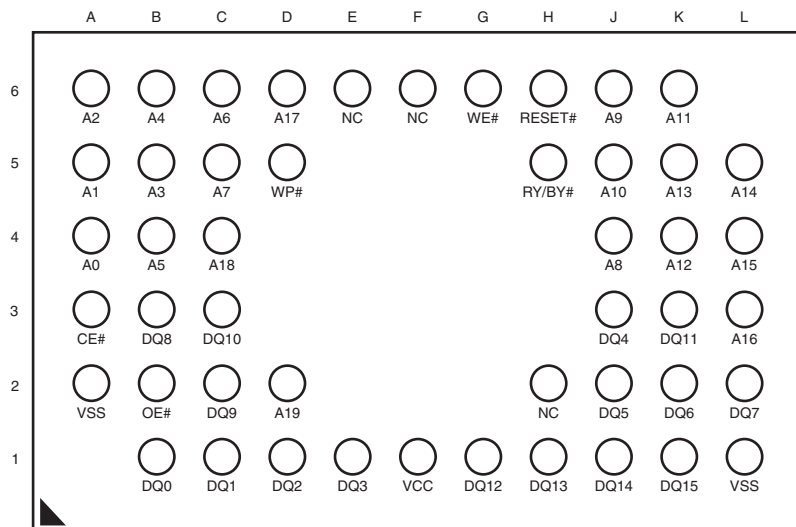

### 3.4 Special Handling Instructions

Special handling is required for Flash Memory products in BGA packages.

Flash memory devices in BGA packages may be damaged if exposed to ultrasonic cleaning methods.

The package and/or data integrity may be compromised if the package body is exposed to temperatures above 150°C for prolonged periods of time.

## 4. Pin Configuration

A0–A19	20 addresses
DQ0–DQ14	15 data inputs/outputs
DQ15/A-1	DQ15 (data input/output, word mode), A-1 (LSB address input, byte mode)
BYTE#	Selects 8-bit or 16-bit mode
CE#	Chip enable
OE#	Output enable
WE#	Write enable
WP#	Write protect: The WP# contains an internal pull-up; when unconnected, WP is at $V_{IH}$ .
RESET#	Hardware reset pin
RY/BY#	Ready/Busy output
$V_{CC}$	1.8 volt-only single power supply (see <a href="#">Section 1. Product Selector Guide</a> on page 4 for speed options and voltage supply tolerances)
$V_{SS}$	Device ground
NC	Pin not connected internally

## 5. Logic Symbol

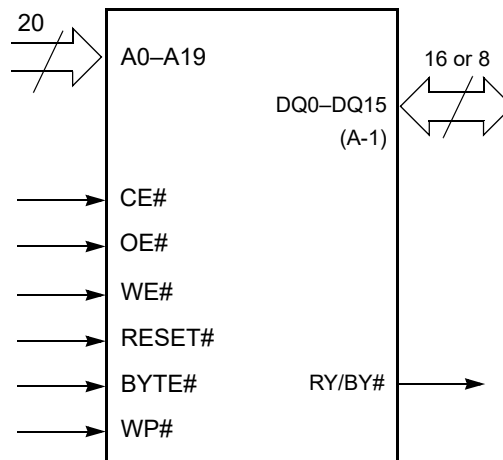

## 6. Ordering Information

### 6.1 S29AS016J Standard Products

Cypress standard products are available in several packages and operating ranges. The order number (Valid Combination) is formed by a combination of the elements below.

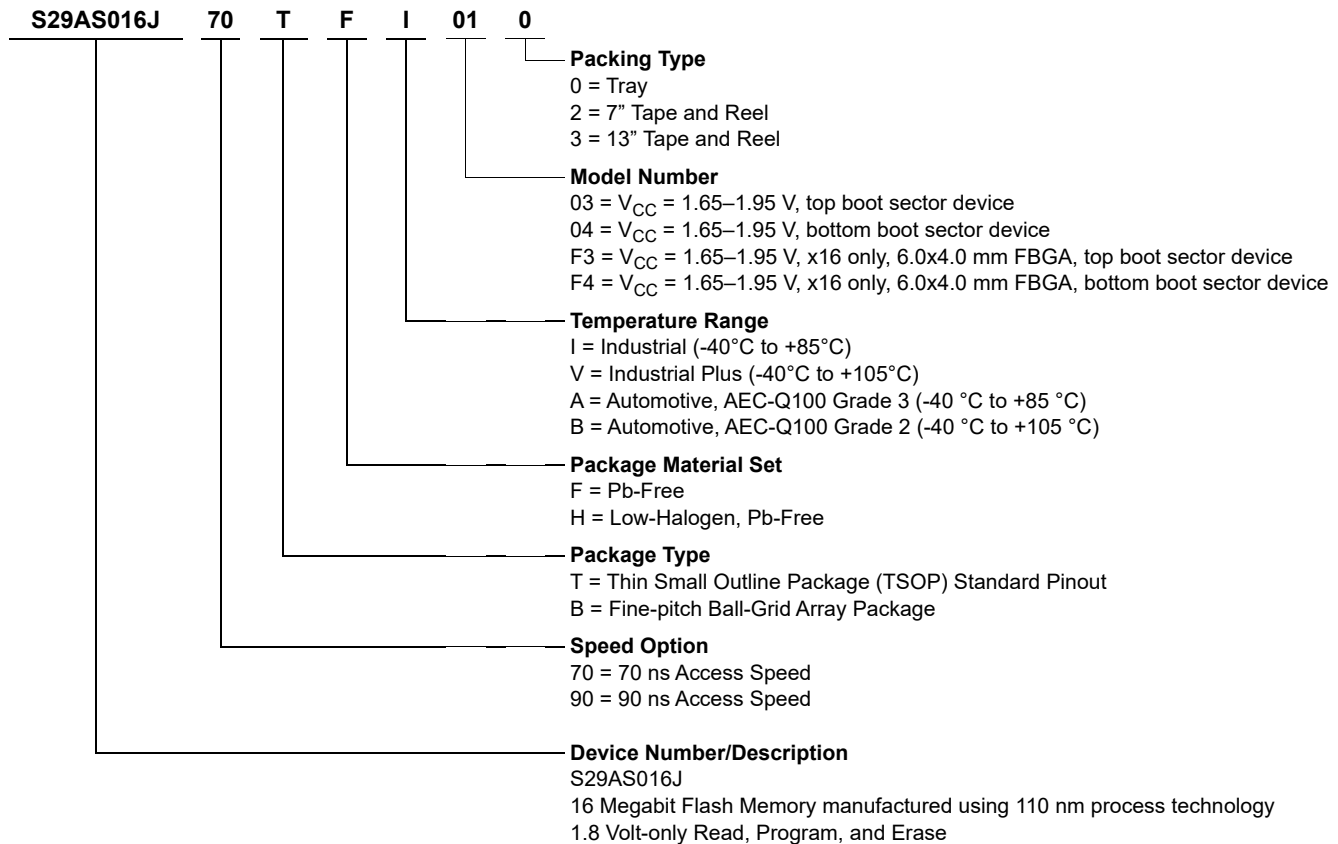

### 6.1.1 Valid Combinations

Valid Combinations list configurations planned to be supported in volume for this device. Contact your local sales office to confirm availability of specific valid combinations and to check on newly released combinations.

S29AS016J Valid Combinations						
Device Number	Speed Option	Package Type, Material, and Temperature Range	Model Number	Packing Type	Package Description	
S29AS016J	70	TFI	03, 04	0, 3 <sup>[2]</sup>	TS048 <sup>[3]</sup>	TSOP
		BFI, BHI		0, 2, 3 <sup>[2]</sup>	VBK048	Fine-Pitch BGA <sup>[4]</sup>
		BHI	F3, F4		VDF048	
		BFV, BHV	03, 04		VBK048	
	90	BFV, BHV	03, 04	VBK048		

### 6.1.2 Valid Combinations - Automotive Grade / AEC-Q100

Valid Combinations list configurations that are Automotive Grade / AEC-Q100 qualified and are planned to be available in volume. This table will be updated as new combinations are released. Contact your local sales representative to confirm availability of specific combinations and to check on newly released combinations.

Production Part Approval Process (PPAP) support is only provided for AEC-Q100 grade products.

Products to be used in end-use applications that require ISO/TS-16949 compliance must be AEC-Q100 grade products in combination with PPAP. Non-AEC-Q100 grade products are not manufactured or documented in full compliance with ISO/TS-16949 requirements.

AEC-Q100 grade products are also offered without PPAP support for end-use applications that do not require ISO/TS-16949 compliance.

S29AS016J Valid Combinations						
Device Number	Speed Option	Package Type, Material, and Temperature Range	Model Number	Packing Type	Package Description	
S29AS016J	70	TFA	03, 04	0, 3 <sup>[2]</sup>	TS048 <sup>[3]</sup>	TSOP
		BFA, BHA		0, 2, 3 <sup>[2]</sup>	VBK048	Fine-Pitch BGA <sup>[4]</sup>
		BHA	F3, F4		VDF048	
		BFB, BHB	03, 04		VBK048	
	90	BFB, BHB	03, 04	VBK048		

**Notes**

- 2. Type 0 is standard. Specify other options as required.
- 3. TSOP package markings omit packing type designator from ordering part number.
- 4. BGA package marking omits leading "S29" and packing type designator from ordering part number.

## 7. Device Bus Operations

This section describes the requirements and use of the device bus operations, which are initiated through the internal command register. The command register itself does not occupy any addressable memory location. The register is composed of latches that store the commands, along with the address and data information needed to execute the command. The contents of the register serve as inputs to the internal state machine. The state machine outputs dictate the function of the device. [Table 1](#) lists the device bus operations, the inputs and control levels they require, and the resulting output. The following subsections describe each of these operations in further detail.

**Table 1. S29AS016J Device Bus Operations**

Operation	CE#	OE#	WE#	RESET#	WP#	Addresses <sup>[5]</sup>	DQ0–DQ7	DQ8–DQ15	
								BYTE# = V <sub>IH</sub>	BYTE# = V <sub>IL</sub>
Read	L	L	H	H	X	A <sub>IN</sub>	D <sub>OUT</sub>	D <sub>OUT</sub>	DQ8–DQ14 = High-Z, DQ15 = A-1
Write (Program/Erase)	L	H	L	H	Note [7]	A <sub>IN</sub>	D <sub>IN</sub>	D <sub>IN</sub>	
Standby	V <sub>CC</sub> ± 0.2 V	X	X	V <sub>CC</sub> ± 0.2 V	H	X	High-Z	High-Z	High-Z
Output Disable	L	H	H	H	X	X	High-Z	High-Z	High-Z
Reset	X	X	X	L	X	X	High-Z	High-Z	High-Z
Sector Group Protect <sup>[6]</sup>	L	H	L	V <sub>ID</sub>	X	Sector Address, A6 = L, A3 = A2 = L, A1 = H, A0 = L	D <sub>IN</sub>	X	X
Sector Group Unprotect <sup>[6]</sup>	L	H	L	V <sub>ID</sub>	H	Sector Address, A6 = H, A3 = A2 = L, A1 = H, A0 = L	D <sub>IN</sub>	X	X
Temporary Sector Group Unprotect	X	X	X	V <sub>ID</sub>	H	A <sub>IN</sub>	D <sub>IN</sub>	D <sub>IN</sub>	High-Z

**Notes**

5. Addresses are A19:A0 in word mode (BYTE# = V<sub>IH</sub>), A19:A-1 in byte mode (BYTE# = V<sub>IL</sub>).
6. The sector group protect and sector group unprotect functions may also be implemented via programming equipment. See [Section 7.11 Sector Group Protection/Unprotection on page 17](#).
7. If WP# = V<sub>IL</sub>, the two outermost boot sectors remain protected. If WP# = V<sub>IH</sub>, the two outermost boot sector group protection depends on whether they were last protected or unprotected.

**Legend**

L = Logic Low = V<sub>IL</sub>, H = Logic High = V<sub>IH</sub>, V<sub>ID</sub> = 9.0 - 11.0 V, X = Don't Care, A<sub>IN</sub> = Address In, D<sub>IN</sub> = Data In, D<sub>OUT</sub> = Data Out

## 7.1 Word/Byte Configuration

The BYTE# pin controls whether the device data I/O pins DQ15–DQ0 operate in the byte or word configuration. If the BYTE# pin is set at logic 1, the device is in word configuration, DQ15–DQ0 are active and controlled by CE# and OE#.

If the BYTE# pin is set at logic 0, the device is in byte configuration, and only data I/O pins DQ0–DQ7 are active and controlled by CE# and OE#. The data I/O pins DQ8–DQ14 are tri-stated, and the DQ15 pin is used as an input for the LSB (A-1) address function.

## 7.2 Requirements for Reading Array Data

To read array data from the outputs, the system must drive the CE# and OE# pins to  $V_{IL}$ . CE# is the power control and selects the device. OE# is the output control and gates array data to the output pins. WE# should remain at  $V_{IH}$ . The BYTE# pin determines whether the device outputs array data in words or bytes.

The internal state machine is set for reading array data upon device power-up, or after a hardware reset. This ensures that no spurious alteration of the memory content occurs during the power transition. No command is necessary in this mode to obtain array data. Standard microprocessor read cycles that assert valid addresses on the device address inputs produce valid data on the device data outputs. The device remains enabled for read access until the command register contents are altered.

See [Section 10.1 Reading Array Data on page 27](#) for more information. Refer to the AC [Section 18.1 Read Operations on page 42](#) for timing specifications and [Figure 12 on page 42](#) for the timing diagram.  $I_{CC1}$  in [Section 15. DC Characteristics on page 40](#) represents the active current specification for reading array data.

## 7.3 Writing Commands/Command Sequences

To write a command or command sequence (which includes programming data to the device and erasing sectors of memory), the system must drive WE# and CE# to  $V_{IL}$ , and OE# to  $V_{IH}$ .

For program operations, the BYTE# pin determines whether the device accepts program data in bytes or words. See [Section 7.1 Word/Byte Configuration on page 12](#) for more information.

The device features an **Unlock Bypass** mode to facilitate faster programming. Once the device enters the Unlock Bypass mode, only two write cycles are required to program a word or byte, instead of four. [Section 10.5 Word/Byte Program Command Sequence on page 28](#) has details on programming data to the device using both standard and Unlock Bypass command sequences.

An erase operation can erase one sector, multiple sectors, or the entire device. [Table 3 on page 15](#) and [Table 4 on page 16](#) indicate the address space that each sector occupies. A “sector address” consists of the address bits required to uniquely select a sector. The [Section 10. Command Definitions on page 27](#) has details on erasing a sector or the entire chip, or suspending/resuming the erase operation.

After the system writes the autoselect command sequence, the device enters the autoselect mode. The system can then read autoselect codes from the internal register (which is separate from the memory array) on DQ7–DQ0. Standard read cycle timings apply in this mode. Refer to [Section 7.9 Autoselect Mode on page 14](#) and [Section 10.3 Autoselect Command Sequence on page 27](#) for more information.

$I_{CC2}$  in [Section 15. DC Characteristics on page 40](#) represents the active current specification for the write mode. [Section 18. AC Characteristics on page 42](#) contains timing specification tables and timing diagrams for write operations.

## 7.4 Program and Erase Operation Status

During an erase or program operation, the system may check the status of the operation by reading the status bits on DQ7–DQ0. Standard read cycle timings and  $I_{CC}$  read specifications apply. Refer to [Section 12. Write Operation Status on page 34](#) for more information, and to [Section 18. AC Characteristics on page 42](#) for timing diagrams.

## 7.5 Standby Mode

When the system is not reading or writing to the device, it can place the device in the standby mode. In this mode, current consumption is greatly reduced, and the outputs are placed in the high impedance state, independent of the OE# input.

The device enters the CMOS standby mode when the CE# and RESET# pins are both held at  $V_{CC} \pm 0.2$  V. (Note that this is a more restricted voltage range than  $V_{IH}$ .) If CE# and RESET# are held at  $V_{IH}$ , but not within  $V_{CC} \pm 0.2$  V, the device will be in the standby mode, but the standby current will be greater. The device requires standard access time ( $t_{CE}$ ) for read access when the device is in either of these standby modes, before it is ready to read data.

If the device is deselected during erasure or programming, the device draws active current until the operation is completed.

$I_{CC3}$  and  $I_{CC4}$  represents the standby current specification shown in the table in [Section 15. DC Characteristics on page 40](#).

## 7.6 Automatic Sleep Mode

The automatic sleep mode minimizes Flash device energy consumption. The device automatically enables this mode when addresses remain stable for  $t_{ACC} + 30$  ns. The automatic sleep mode is independent of the CE#, WE#, and OE# control signals. Standard address access timings provide new data when addresses are changed. While in sleep mode, output data is latched and always available to the system.  $I_{CC5}$  in the [Section 15. DC Characteristics on page 40](#) represents the automatic sleep mode current specification.

## 7.7 RESET#: Hardware Reset Pin

The RESET# pin provides a hardware method of resetting the device to reading array data. When the system drives the RESET# pin to  $V_{IL}$  for at least a period of  $t_{RP}$ , the device **immediately terminates** any operation in progress, tristates all data output pins, and ignores all read/write attempts for the duration of the RESET# pulse. The device also resets the internal state machine to reading array data. The operation that was interrupted should be reinitiated once the device is ready to accept another command sequence, to ensure data integrity.

Current is reduced for the duration of the RESET# pulse. When RESET# is held at  $V_{SS} \pm 0.2$  V, the device draws CMOS standby current ( $I_{CC4}$ ). If RESET# is held at  $V_{IL}$  but not within  $V_{SS} \pm 0.2$  V, the standby current will be greater.

The RESET# pin may be tied to the system reset circuitry. A system reset would thus also reset the Flash memory, enabling the system to read the boot-up firmware from the Flash memory. Note that the CE# pin should only go to  $V_{IL}$  after RESET# has gone to  $V_{IH}$ . Keeping CE# at  $V_{IL}$  from power up through the first read could cause the first read to retrieve erroneous data.

If RESET# is asserted during a program or erase operation, the RY/BY# pin remains a 0 (busy) until the internal reset operation is complete, which requires a time of  $t_{READY}$  (during Embedded Algorithms). The system can thus monitor RY/BY# to determine whether the reset operation is complete. If RESET# is asserted when a program or erase operation is not executing (RY/BY# pin is 1), the reset operation is completed within a time of  $t_{READY}$  (not during Embedded Algorithms). The system can read data  $t_{RH}$  after the RESET# pin returns to  $V_{IH}$ .

Refer to the tables in [Section 18. AC Characteristics on page 42](#) for RESET# parameters and to [Figure 13 on page 43](#) for the timing diagram. If  $V_{ID}$  (9.0 V – 11.0 V) is applied to the RESET# pin, the device will enter the Temporary Sector Group Unprotect mode. See [Section 7.12 Temporary Sector Group Unprotect on page 20](#) for more details on this feature.

## 7.8 Output Disable Mode

When the OE# input is at  $V_{IH}$ , output from the device is disabled. The output pins are placed in the high impedance state.

## 7.9 Autoselect Mode

The autoselect mode provides manufacturer and device identification, sector group protection verification, and Secured Silicon Sector status through identifier codes output on DQ7–DQ0. This mode is primarily intended for programming equipment to automatically match a device to be programmed with its corresponding programming algorithm. However, the autoselect codes can also be accessed in-system through the command register.

When using programming equipment, the autoselect mode requires  $V_{ID}$  (9.0 V to 11.0 V) on address pin A9. Address pins A6, A3, A2, A1, and A0 must be as shown in Table 2. In addition, when verifying sector group protection, the sector address must appear on the appropriate highest order address bits (see Table 3 on page 15 and Table 4 on page 16). Table 2 shows the remaining address bits that are don't care. When all necessary bits have been set as required, the programming equipment may then read the corresponding identifier code on DQ7–DQ0.

To access the autoselect codes in-system, the host system can issue the autoselect command via the command register, as shown in Table 11 on page 32. This method does not require  $V_{ID}$ . See Section 10. Command Definitions on page 27 for details on using the autoselect mode.

**Table 2. S29AS016J Autoselect Codes (High Voltage Method)**

Description	CE#	OE#	WE#	A19 to A12	A11 to A10	A9	A8 to A7	A6	A5 to A4	A3 to A2	A1	A0	DQ8 to DQ15		DQ7 to DQ0	
													BYTE = $V_{IH}$	BYTE = $V_{IL}$		
Manufacturer ID: Cypress	L	L	H	X	X	$V_{ID}$	X	L	X	L	L	L	00h	X	01h	
Device ID	Cycle 1	L	L	H	X	X	$V_{ID}$	X	L	X	L	L	H	22h	X	7Eh
	Cycle 2	L	L	H	X	X	$V_{ID}$	X	L	X	H	H	L	22h	X	03h
	Cycle 3	L	L	H	X	X	$V_{ID}$	X	L	X	H	H	H	22h	X	04h (Top Boot), 03h (Bottom Boot)
Sector Group Protection Verification	L	L	H	SA	X	$V_{ID}$	X	L	X	L	H	L	X	X	01h (protected), 00h (unprotected)	
Secured Silicon Sector Indicator Bit (DQ7), WP# protects highest address sector	L	L	H	X	X	$V_{ID}$	X	L	X	L	H	H	X	X	89h (factory locked), 09h (not factory locked)	
Secured Silicon Sector Indicator Bit (DQ7), WP# protects lowest address sector	L	L	H	X	X	$V_{ID}$	X	L	X	L	H	H	X	X	91h (factory locked), 11h (not factory locked)	

**Note**

8. The autoselect codes may also be accessed in-system via command sequences. See Table 11 on page 32.

**Legend**

L = Logic Low =  $V_{IL}$ , H = Logic High =  $V_{IH}$ , SA = Sector Address, X = Don't care

## 7.10 Sector Address Tables

**Table 3. Sector Address Table (Top Boot Device)**

Sector	A19	A18	A17	A16	A15	A14	A13	A12	Sector Size (Kbytes/Kwords)	Address Range (in hexadecimal)	
										Byte Mode (x8)	Word Mode (x16)
SA0	0	0	0	0	0	X	X	X	64/32	000000–00FFFF	00000–07FFF
SA1	0	0	0	0	1	X	X	X	64/32	010000–01FFFF	08000–0FFFF
SA2	0	0	0	1	0	X	X	X	64/32	020000–02FFFF	10000–17FFF
SA3	0	0	0	1	1	X	X	X	64/32	030000–03FFFF	18000–1FFFF
SA4	0	0	1	0	0	X	X	X	64/32	040000–04FFFF	20000–27FFF
SA5	0	0	1	0	1	X	X	X	64/32	050000–05FFFF	28000–2FFFF
SA6	0	0	1	1	0	X	X	X	64/32	060000–06FFFF	30000–37FFF
SA7	0	0	1	1	1	X	X	X	64/32	070000–07FFFF	38000–3FFFF
SA8	0	1	0	0	0	X	X	X	64/32	080000–08FFFF	40000–47FFF
SA9	0	1	0	0	1	X	X	X	64/32	090000–09FFFF	48000–4FFFF
SA10	0	1	0	1	0	X	X	X	64/32	0A0000–0AFFFF	50000–57FFF
SA11	0	1	0	1	1	X	X	X	64/32	0B0000–0BFFFF	58000–5FFFF
SA12	0	1	1	0	0	X	X	X	64/32	0C0000–0CFFFF	60000–67FFF
SA13	0	1	1	0	1	X	X	X	64/32	0D0000–0DFFFF	68000–6FFFF
SA14	0	1	1	1	0	X	X	X	64/32	0E0000–0EFFFF	70000–77FFF
SA15	0	1	1	1	1	X	X	X	64/32	0F0000–0FFFFF	78000–7FFFF
SA16	1	0	0	0	0	X	X	X	64/32	100000–10FFFF	80000–87FFF
SA17	1	0	0	0	1	X	X	X	64/32	110000–11FFFF	88000–8FFFF
SA18	1	0	0	1	0	X	X	X	64/32	120000–12FFFF	90000–97FFF
SA19	1	0	0	1	1	X	X	X	64/32	130000–13FFFF	98000–9FFFF
SA20	1	0	1	0	0	X	X	X	64/32	140000–14FFFF	A0000–A7FFF
SA21	1	0	1	0	1	X	X	X	64/32	150000–15FFFF	A8000–AFFFF
SA22	1	0	1	1	0	X	X	X	64/32	160000–16FFFF	B0000–B7FFF
SA23	1	0	1	1	1	X	X	X	64/32	170000–17FFFF	B8000–BFFFF
SA24	1	1	0	0	0	X	X	X	64/32	180000–18FFFF	C0000–C7FFF
SA25	1	1	0	0	1	X	X	X	64/32	190000–19FFFF	C8000–CFFFF
SA26	1	1	0	1	0	X	X	X	64/32	1A0000–1AFFFF	D0000–D7FFF
SA27	1	1	0	1	1	X	X	X	64/32	1B0000–1BFFFF	D8000–DFFFF
SA28	1	1	1	0	0	X	X	X	64/32	1C0000–1CFFFF	E0000–E7FFF
SA29	1	1	1	0	1	X	X	X	64/32	1D0000–1DFFFF	E8000–EFFFF
SA30	1	1	1	1	0	X	X	X	64/32	1E0000–1EFFFF	F0000–F7FFF
SA31	1	1	1	1	1	0	0	0	8/4	1F0000–1F1FFF	F8000–F8FFF
SA32	1	1	1	1	1	0	0	1	8/4	1F2000–1F3FFF	F9000–F9FFF
SA33	1	1	1	1	1	0	1	0	8/4	1F4000–1F5FFF	FA000–FAFFF
SA34	1	1	1	1	1	0	1	1	8/4	1F6000–1F7FFF	FB000–FBFFF
SA35	1	1	1	1	1	1	0	0	8/4	1F8000–1F9FFF	FC000–FCFFF
SA36	1	1	1	1	1	1	0	1	8/4	1FA000–1FBFFF	FD000–FDFFF
SA37	1	1	1	1	1	1	1	0	8/4	1FC000–1FDFFF	FE000–FEFFF
SA38	1	1	1	1	1	1	1	1	8/4	1FE000–1FFFFF	FF000–FFFFF

**Note**

9. Address range is A19:A-1 in byte mode and A19:A0 in word mode. See [Section 7.1 Word/Byte Configuration](#) on page 12.

**Table 4. Sector Address Table (Bottom Boot Device)**

Sector	A19	A18	A17	A16	A15	A14	A13	A12	Sector Size (Kbytes/Kwords)	Address Range (in hexadecimal)	
										Byte Mode (x8)	Word Mode (x16)
SA0	0	0	0	0	0	0	0	0	8/4	000000–001FFF	00000–00FFF
SA1	0	0	0	0	0	0	0	1	8/4	002000–003FFF	01000–01FFF
SA2	0	0	0	0	0	0	0	1	8/4	004000–005FFF	02000–02FFF
SA3	0	0	0	0	0	0	0	1	8/4	006000–007FFF	03000–03FFF
SA4	0	0	0	0	0	0	1	0	8/4	008000–009FFF	04000–04FFF
SA5	0	0	0	0	0	0	1	0	8/4	00A000–00BFFF	05000–05FFF
SA6	0	0	0	0	0	0	1	1	8/4	00C000–00DFFF	06000–06FFF
SA7	0	0	0	0	0	0	1	1	8/4	00E000–00FFFF	07000–07FFF
SA8	0	0	0	0	1	X	X	X	64/32	010000–01FFFF	08000–0FFFF
SA9	0	0	0	1	0	X	X	X	64/32	020000–02FFFF	10000–17FFF
SA10	0	0	0	1	1	X	X	X	64/32	030000–03FFFF	18000–1FFFF
SA11	0	0	1	0	0	X	X	X	64/32	040000–04FFFF	20000–27FFF
SA12	0	0	1	0	1	X	X	X	64/32	050000–05FFFF	28000–2FFFF
SA13	0	0	1	1	0	X	X	X	64/32	060000–06FFFF	30000–37FFF
SA14	0	0	1	1	1	X	X	X	64/32	070000–07FFFF	38000–3FFFF
SA15	0	1	0	0	0	X	X	X	64/32	080000–08FFFF	40000–47FFF
SA16	0	1	0	0	1	X	X	X	64/32	090000–09FFFF	48000–4FFFF
SA17	0	1	0	1	0	X	X	X	64/32	0A0000–0AFFFF	50000–57FFF
SA18	0	1	0	1	1	X	X	X	64/32	0B0000–0BFFFF	58000–5FFFF
SA19	0	1	1	0	0	X	X	X	64/32	0C0000–0CFFFF	60000–67FFF
SA20	0	1	1	0	1	X	X	X	64/32	0D0000–0DFFFF	68000–6FFFF
SA21	0	1	1	1	0	X	X	X	64/32	0E0000–0EFFFF	70000–77FFF
SA22	0	1	1	1	1	X	X	X	64/32	0F0000–0FFFFF	78000–7FFFF
SA23	1	0	0	0	0	X	X	X	64/32	100000–10FFFF	80000–87FFF
SA24	1	0	0	0	1	X	X	X	64/32	110000–11FFFF	88000–8FFFF
SA25	1	0	0	1	0	X	X	X	64/32	120000–12FFFF	90000–97FFF
SA26	1	0	0	1	1	X	X	X	64/32	130000–13FFFF	98000–9FFFF
SA27	1	0	1	0	0	X	X	X	64/32	140000–14FFFF	A0000–A7FFF
SA28	1	0	1	0	1	X	X	X	64/32	150000–15FFFF	A8000–AFFFF
SA29	1	0	1	1	0	X	X	X	64/32	160000–16FFFF	B0000–B7FFF
SA30	1	0	1	1	1	X	X	X	64/32	170000–17FFFF	B8000–BFFFF
SA31	1	1	0	0	0	X	X	X	64/32	180000–18FFFF	C0000–C7FFF
SA32	1	1	0	0	1	X	X	X	64/32	190000–19FFFF	C8000–CFFFF
SA33	1	1	0	1	0	X	X	X	64/32	1A0000–1AFFFF	D0000–D7FFF
SA34	1	1	0	1	1	X	X	X	64/32	1B0000–1BFFFF	D8000–DFFFF
SA35	1	1	1	0	0	X	X	X	64/32	1C0000–1CFFFF	E0000–E7FFF
SA36	1	1	1	0	1	X	X	X	64/32	1D0000–1DFFFF	E8000–EFFFF
SA37	1	1	1	1	0	X	X	X	64/32	1E0000–1EFFFF	F0000–F7FFF
SA38	1	1	1	1	1	X	X	X	64/32	1F0000–1FFFFF	F8000–FFFFF

**Note**

 10. Address range is A19:A-1 in byte mode and A19:A0 in word mode. See [Section 7.1 Word/Byte Configuration](#) on page 12.

## 7.11 Sector Group Protection/Unprotection

The hardware sector group protection feature disables both program and erase operations in any sector group (see [Table 3 on page 15](#) to [Table 6 on page 18](#)). The hardware sector group unprotection feature re-enables both program and erase operations in previously protected sector groups. Sector group protection/unprotection can be implemented via two methods.

Sector group protection/unprotection requires VID on the RESET# pin only, and can be implemented either in-system or via programming equipment. [Figure 1 on page 19](#) shows the algorithms and [Figure 12 on page 42](#) shows the timing diagram. This method uses standard microprocessor bus cycle timing. For sector group unprotect, all unprotected sector groups must first be protected prior to the first sector group unprotect write cycle.

The device is shipped with all sector groups unprotected. Cypress offers the option of programming and protecting sector groups at its factory prior to shipping the device through Cypress Programming Service. Contact a Cypress representative for details.

It is possible to determine whether a sector group is protected or unprotected. See [Section 7.9 Autoselect Mode on page 14](#) for details.

**Table 5. AS016J Top Boot Device Sector/Sector Group Protection**

Sector / Sector Block	A19	A18	A17	A16	A15	A14	A13	A12	Sector / Sector Block Size
SA0-SA3	0	0	0	X	X	X	X	X	256 (4x64) Kbytes
SA4-SA7	0	0	1	X	X	X	X	X	256 (4x64) Kbytes
SA8-SA11	0	1	0	X	X	X	X	X	256 (4x64) Kbytes
SA12-SA15	0	1	1	X	X	X	X	X	256 (4x64) Kbytes
SA16-SA19	1	0	0	X	X	X	X	X	256 (4x64) Kbytes
SA20-SA23	1	0	1	X	X	X	X	X	256 (4x64) Kbytes
SA24-SA27	1	1	0	X	X	X	X	X	256 (4x64) Kbytes
SA28-SA29	1	1	1	0	X	X	X	X	128 (2x64) Kbytes
SA30	1	1	1	1	0	X	X	X	64 Kbytes
SA31	1	1	1	1	1	0	0	0	8 Kbytes
SA32	1	1	1	1	1	0	0	1	8 Kbytes
SA33	1	1	1	1	1	0	1	0	8 Kbytes
SA34	1	1	1	1	1	0	1	1	8 Kbytes
SA35	1	1	1	1	1	1	0	0	8 Kbytes
SA36	1	1	1	1	1	1	0	1	8 Kbytes
SA37	1	1	1	1	1	1	1	0	8 Kbytes
SA38	1	1	1	1	1	1	1	1	8 Kbytes

**Table 6. AS016J Bottom Boot Device Sector/Sector Group Protection**

Sector / Sector Block	A19	A18	A17	A16	A15	A14	A13	A12	Sector / Sector Block Size
SA0	0	0	0	0	0	0	0	0	8 Kbytes
SA1	0	0	0	0	0	0	0	1	8 Kbytes
SA2	0	0	0	0	0	0	1	0	8 Kbytes
SA3	0	0	0	0	0	0	1	1	8 Kbytes
SA4	0	0	0	0	0	1	0	0	8 Kbytes
SA5	0	0	0	0	0	1	0	1	8 Kbytes
SA6	0	0	0	0	0	1	1	0	8 Kbytes
SA7	0	0	0	0	0	1	1	1	8 Kbytes
SA8	0	0	0	0	1	X	X	X	64 Kbytes
SA9-SA10	0	0	0	1	X	X	X	X	128 (2x64) Kbytes
SA11-SA14	0	0	1	X	X	X	X	X	256 (4x64) Kbytes
SA15-SA18	0	1	0	X	X	X	X	X	256 (4x64) Kbytes
SA19-SA22	0	1	1	X	X	X	X	X	256 (4x64) Kbytes
SA23-SA26	1	0	0	X	X	X	X	X	256 (4x64) Kbytes
SA27-SA30	1	0	1	X	X	X	X	X	256 (4x64) Kbytes
SA31-SA34	1	1	0	X	X	X	X	X	256 (4x64) Kbytes
SA35-SA38	1	1	1	X	X	X	X	X	256 (4x64) Kbytes

Figure 1. In-System Sector Group Protect/Unprotect Algorithms

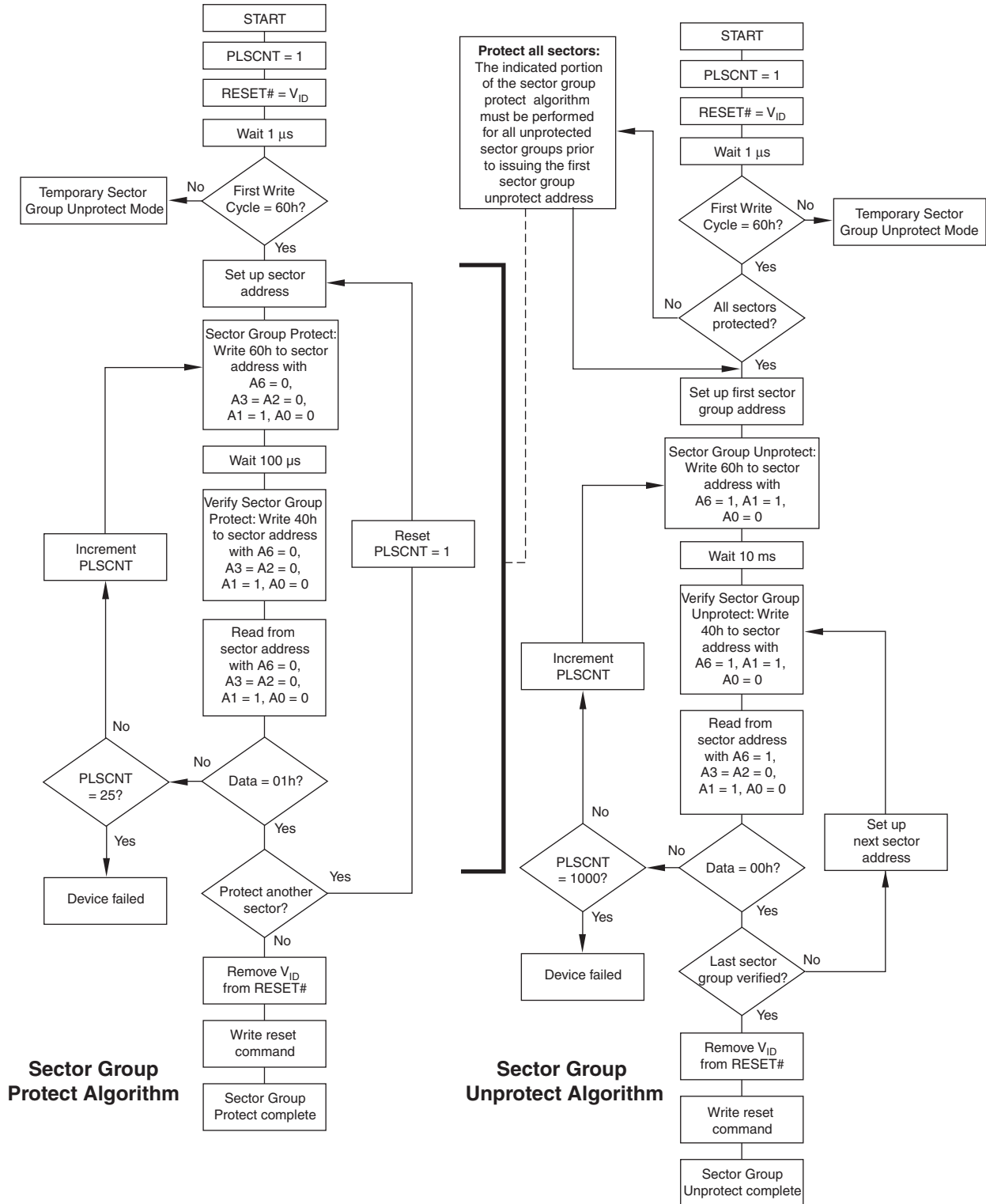

**Note**  
11. If WP# = V<sub>IL</sub>, the top or bottom two address sectors remains protected for boot sector devices).

## 7.12 Temporary Sector Group Unprotect

This feature allows temporary unprotection of previously protected sectors to change data in-system. The Sector Group Unprotect mode is activated by setting the RESET# pin to  $V_{ID}$ . During this mode, formerly protected sectors can be programmed or erased by selecting the sector addresses. Once  $V_{ID}$  is removed from the RESET# pin, all the previously protected sectors are protected again. [Figure 2](#) shows the algorithm, and [Figure 21 on page 48](#) shows the timing diagrams, for this feature. If the WP# pin is at  $V_{IL}$ , the sectors protected by the WP# input will remain protected during the Temporary Sector Group Unprotect mode.

**Figure 2. Temporary Sector Group Unprotect Operation**

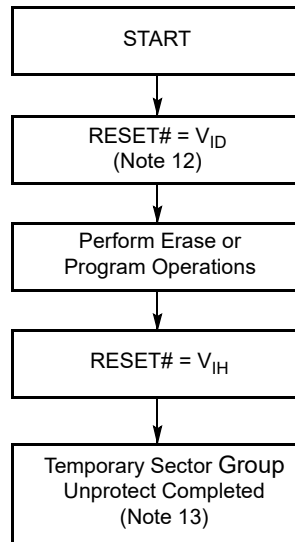

## 7.13 Write Protect (WP#)

The Write Protect function provides a hardware method of protecting certain boot sectors without using VID. This function is one of two provided by the WP# pin.

If the system asserts  $V_{IL}$  on the WP# pin, the device disables program and erase functions in the two outermost 8-Kbyte boot sectors independently of whether those sectors were protected or unprotected using the method described in [Section 7.11 Sector Group Protection/Unprotection on page 17](#). The two outermost 8-Kbyte boot sectors are the two sectors containing the lowest addresses in a bottom-boot-configured device, or the two sectors containing the highest addresses in a top-boot-configured device.

If the system asserts  $V_{IH}$  on the WP# pin, the device reverts to whether the two outermost 8-KByte boot sectors were last set to be protected or unprotected. That is, sector group protection or unprotection for these two sectors depends on whether they were last protected or unprotected using the method described in [Section 7.11 Sector Group Protection/Unprotection on page 17](#).

The WP# contains an internal pull-up; when unconnected, WP is at  $V_{IH}$ .

## 7.14 Hardware Data Protection

The command sequence requirement of unlock cycles for programming or erasing provides data protection against inadvertent writes (refer to [Table 11 on page 32](#) for command definitions). In addition, the following hardware data protection measures prevent accidental erasure or programming, which might otherwise be caused by spurious system level signals during  $V_{CC}$  power-up and power-down transitions, or from system noise.

### Notes

- 12. All protected sector groups unprotected.
- 13. All previously protected sector groups are protected once again.

### 7.14.1 Low $V_{CC}$ Write Inhibit

When  $V_{CC}$  is less than  $V_{LKO}$ , the device does not accept any write cycles. This protects data during  $V_{CC}$  power-up and power-down. The command register and all internal program/erase circuits are disabled, and the device resets. Subsequent writes are ignored until  $V_{CC}$  is greater than  $V_{LKO}$ . The system must provide the proper signals to the control pins to prevent unintentional writes when  $V_{CC}$  is greater than  $V_{LKO}$ .

### 7.14.2 Write Pulse *Glitch* Protection

Noise pulses of less than 5 ns (typical) on OE#, CE# or WE# do not initiate a write cycle.

### 7.14.3 Logical Inhibit

Write cycles are inhibited by holding any one of OE# =  $V_{IL}$ , CE# =  $V_{IH}$  or WE# =  $V_{IH}$ . To initiate a write cycle, CE# and WE# must be a logical zero ( $V_{IL}$ ) while OE# is a logical one ( $V_{IH}$ ).

### 7.14.4 Power-Up Write Inhibit

If WE# = CE# =  $V_{IL}$  and OE# =  $V_{IH}$  during power up, the device does not accept commands on the rising edge of WE#. The internal state machine is automatically reset to reading array data on power-up.

## 8. Secured Silicon Sector Flash Memory Region

The Secured Silicon Sector feature provides a 256-byte Flash memory region that enables permanent part identification through an Electronic Serial Number (ESN). The Secured Silicon Sector uses a Secured Silicon Sector Indicator Bit (DQ7) to indicate whether or not the Secured Silicon Sector is locked when shipped from the factory. This bit is permanently set at the factory and cannot be changed, which prevents cloning of a factory-locked part. This ensures the security of the ESN once the product is shipped to the field.

Cypress offers the device with the Secured Silicon Sector either factory-locked or customer-lockable. The factory-locked version is always protected when shipped from the factory, and has the Secured Silicon Sector Indicator Bit permanently set to a 1. The customer-lockable version is shipped with the Secured Silicon Sector group unprotected, allowing customers to utilize the that sector in any manner they choose. The customer-lockable version has the Secured Silicon Sector Indicator Bit permanently set to a 0. Thus, the Secured Silicon Sector Indicator Bit prevents customer-lockable devices from being used to replace devices that are factory locked.

The system accesses the Secured Silicon Sector through a command sequence (see [Section 10.4 Enter Secured Silicon Sector/Exit Secured Silicon Sector Command Sequence on page 28](#)). After the system writes the Enter Secured Silicon Sector command sequence, it may read the Secured Silicon Sector by using the addresses normally occupied by the boot sectors. This mode of operation continues until the system issues the Exit Secured Silicon Sector command sequence, or until power is removed from the device. On power-up, or following a hardware reset, the device reverts to sending commands to the boot sectors.

### 8.1 Factory Locked: Secured Silicon Sector Programmed and Protected at the Factory

In a factory locked device, the Secured Silicon Sector is protected when the device is shipped from the factory. The Secured Silicon Sector cannot be modified in any way. The device is available pre-programmed with one of the following:

- A random, secure ESN only.
- Customer code through the ExpressFlash service.
- Both a random, secure ESN and customer code through the ExpressFlash service.

In devices that have an ESN, a Bottom Boot device has the 16-byte (8-word) ESN in sector 0 at addresses 00000h–0000Fh in byte mode (or 00000h–00007h in word mode). In the Top Boot device, the ESN is in sector 38 at addresses 1FFFF0–1FFFFF in byte mode (or FFFF8–FFFFF in word mode).

Customers may opt to have their code programmed by Cypress through the Cypress ExpressFlash service. Cypress programs the customer's code, with or without the random ESN. The devices are then shipped from the Cypress factory with the Secured Silicon Sector permanently locked. Contact a Cypress representative for details on using the Cypress ExpressFlash service.

### 8.2 Customer Lockable: Secured Silicon Sector NOT Programmed or Protected at the Factory

The customer lockable version allows the Secured Silicon Sector to be programmed once, and then permanently locked after it ships from Cypress. Note that the unlock bypass function is not available when programming the Secured Silicon Sector.

The Secured Silicon Sector area can be protected using the following procedures:

- Write the three-cycle Enter Secured Silicon Region command sequence, and then follow the in-system sector group protect algorithm as shown in [Figure 1 on page 19](#), substituting the sector group address with the Secured Silicon Sector group address (A0=0, A1=1, A2=0, A3=1, A4=1, A5=0, A6=0, A7=0). This allows in-system protection of the Secured Silicon Sector without raising any device pin to a high voltage. Note that this method is only applicable to the Secured Silicon Sector.
- To verify the protect/unprotect status of the Secured Silicon Sector, follow the algorithm shown in [Figure 3 on page 23](#).

Once the Secured Silicon Sector is locked and verified, the system must write the Exit Secured Silicon Sector Region command sequence to return to reading and writing the remainder of the array.

The Secured Silicon Sector protection must be used with caution since, once protected, there is no procedure available for unprotecting the Secured Silicon Sector area, and none of the bits in the Secured Silicon Sector memory space can be modified in any way.

**Figure 3. Secured Silicon Sector Protect Verify**

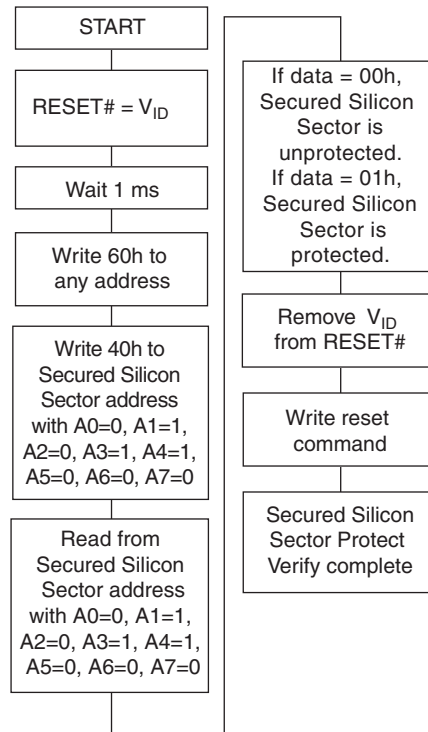

## 9. Common Flash Memory Interface (CFI)

The Common Flash Interface (CFI) specification outlines device and host system software interrogation handshake, which allows specific vendor-specified software algorithms to be used for entire families of devices. Software support can then be device-independent, JEDEC ID-independent, and forward- and backward-compatible for the specified flash device families. Flash vendors can standardize their existing interfaces for long-term compatibility.

This device enters the CFI Query mode when the system writes the CFI Query command, 98h, to address 55h in word mode (or address AAh in byte mode), any time the device is ready to read array data. The system can read CFI information at the addresses given in [Table 7](#) to [Table 10 on page 25](#). In word mode, the upper address bits (A7–MSB) must be all zeros. To terminate reading CFI data, the system must write the reset command.

The system can also write the CFI query command when the device is in the autoselect mode. The device enters the CFI query mode, and the system can read CFI data at the addresses given in [Table 7](#) to [Table 10 on page 25](#). The system must write the reset command to return the device to the autoselect mode.

**Table 7. CFI Query Identification String**

Addresses (Word Mode)	Addresses (Byte Mode)	Data	Description
10h 11h 12h	20h 22h 24h	0051h 0052h 0059h	Query Unique ASCII string “QRY”
13h 14h	26h 28h	0002h 0000h	Primary OEM Command Set
15h 16h	2Ah 2Ch	0040h 0000h	Address for Primary Extended Table
17h 18h	2Eh 30h	0000h 0000h	Alternate OEM Command Set (00h = none exists)
19h 1Ah	32h 34h	0000h 0000h	Address for Alternate OEM Extended Table (00h = none exists)

**Table 8. System Interface String**

Addresses (Word Mode)	Addresses (Byte Mode)	Data	Description
1Bh	36h	0017h	V <sub>CC</sub> Min. (write/erase) D7–D4: volt, D3–D0: 100 millivolt
1Ch	38h	0019h	V <sub>CC</sub> Max. (write/erase) D7–D4: volt, D3–D0: 100 millivolt
1Dh	3Ah	0000h	V <sub>PP</sub> Min. voltage (00h = no V <sub>PP</sub> pin present)
1Eh	3Ch	0000h	V <sub>PP</sub> Max. voltage (00h = no V <sub>PP</sub> pin present)
1Fh	3Eh	0003h	Typical timeout per single byte/word write 2 <sup>N</sup> μs
20h	40h	0000h	Typical timeout for Min. size buffer write 2 <sup>N</sup> μs (00h = not supported)
21h	42h	0009h	Typical timeout per individual block erase 2 <sup>N</sup> ms
22h	44h	0000h	Typical timeout for full chip erase 2 <sup>N</sup> ms (00h = not supported)
23h	46h	0005h	Max. timeout for byte/word write 2 <sup>N</sup> times typical
24h	48h	0000h	Max. timeout for buffer write 2 <sup>N</sup> times typical
25h	4Ah	0004h	Max. timeout per individual block erase 2 <sup>N</sup> times typical
26h	4Ch	0000h	Max. timeout for full chip erase 2 <sup>N</sup> times typical (00h = not supported)

**Table 9. Device Geometry Definition**

Addresses (Word Mode)	Addresses (Byte Mode)	Data	Description
27h	4Eh	0015h	Device Size = 2 <sup>N</sup> byte
28h 29h	50h 52h	0002h 0000h	Flash Device Interface description (refer to CFI publication 100)
2Ah 2Bh	54h 56h	0000h 0000h	Max. number of byte in multi-byte write = 2 <sup>N</sup> (00h = not supported)
2Ch	58h	0002h	Number of Erase Block Regions within device
2Dh 2Eh 2Fh 30h	5Ah 5Ch 5Eh 60h	0007h 0000h 0020h 0000h	Erase Block Region 1 Information (refer to the CFI specification or CFI publication 100)
31h 32h 33h 34h	62h 64h 66h 68h	001Eh 0000h 0000h 0001h	Erase Block Region 2 Information
35h 36h 37h 38h	6Ah 6Ch 6Eh 70h	0000h 0000h 0000h 0000h	Erase Block Region 3 Information
39h 3Ah 3Bh 3Ch	72h 74h 76h 78h	0000h 0000h 0000h 0000h	Erase Block Region 4 Information

**Table 10. Primary Vendor-Specific Extended Query**

Addresses (Word Mode)	Addresses (Byte Mode)	Data	Description
40h 41h 42h	80h 82h 84h	0050h 0052h 0049h	Query-unique ASCII string "PRI"
43h	86h	0031h	Major version number, ASCII
44h	88h	0033h	Minor version number, ASCII
45h	8Ah	000Ch	Address Sensitive Unlock 0 = Required 1 = Not Required
46h	8Ch	0002h	Erase Suspend 0 = Not Supported 1 = To Read Only 2 = To Read & Write
47h	8Eh	0001h	Sector Group Protect 0 = Not Supported X= Number of sectors in smallest sector group
48h	90h	0001h	Sector Group Temporary Unprotect 00 = Not Supported 01 = Supported

**Table 10. Primary Vendor-Specific Extended Query (Continued)**

Addresses (Word Mode)	Addresses (Byte Mode)	Data	Description
49h	92h	0004h	Sector Group Protect/Unprotect scheme 01 = 29F040 mode 02 = 29F016 mode, 03 = 29F400 mode 04 = 29LV800A mode
4Ah	94h	0000h	Simultaneous Operation 00 = Not Supported 01 = Supported
4Bh	96h	0000h	Burst Mode Type 00 = Not Supported 01 = Supported
4Ch	98h	0000h	Page Mode Type 00 = Not Supported 01 = 4 Word Page 02 = 8 Word Page
4Dh	9Ah	0000h	ACC (Acceleration) Supply Minimum 00 = Not Supported D7-D4: Volt D3-D0: 100 mV
4Eh	9Ch	0000h	ACC (Acceleration) Supply Maximum 00 = Not Supported D7-D4: Volt D3-D0: 100 mV
4Fh	9Eh	00XXh	WP# Protection 02 = Bottom Boot Device with WP Protect 03 = Top Boot Device with WP Protect
50h	A0h	0000h	Program Suspend 00 = Not Supported 01 = Supported

## 10. Command Definitions

Writing specific address and data commands or sequences into the command register initiates device operations. [Table 11 on page 32](#) defines the valid register command sequences. Writing **incorrect address and data values** or writing them in the **improper sequence** resets the device to reading array data.

All addresses are latched on the falling edge of WE# or CE#, whichever happens later. All data is latched on the rising edge of WE# or CE#, whichever happens first. Refer to the appropriate timing diagrams in [Section 18. AC Characteristics on page 42](#).

### 10.1 Reading Array Data

The device is automatically set to reading array data after device power-up. No commands are required to retrieve data. The device is also ready to read array data after completing an Embedded Program or Embedded Erase algorithm.

After the device accepts an Erase Suspend command, the device enters the Erase Suspend mode. The system can read array data using the standard read timings, except that if it reads at an address within erase-suspended sectors, the device outputs status data. After completing a programming operation in the Erase Suspend mode, the system may once again read array data with the same exception. See [Section 10.9 Erase Suspend/Erase Resume Commands on page 30](#) for more information on this mode.

The system *must* issue the reset command to re-enable the device for reading array data if DQ5 goes high, or while in the autoselect mode. See [Section 10.2 Reset Command on page 27](#).

See also [Requirements for Reading Array Data on page 12](#) for more information. The [Section 18.1 Read Operations on page 42](#) provides the read parameters, and [Figure 12 on page 42](#) shows the timing diagram.

### 10.2 Reset Command

Writing the reset command to the device resets the device to reading array data. Address bits are don't care for this command.

The reset command may be written between the sequence cycles in an erase command sequence before erasing begins. This resets the device to reading array data. Once erasure begins, however, the device ignores reset commands until the operation is complete.

The reset command may be written between the sequence cycles in a program command sequence before programming begins. This resets the device to reading array data (also applies to programming in Erase Suspend mode). Once programming begins, however, the device ignores reset commands until the operation is complete.

The reset command may be written between the sequence cycles in an autoselect command sequence. Once in the autoselect mode, the reset command *must* be written to return to reading array data (also applies to autoselect during Erase Suspend).

If DQ5 goes high during a program or erase operation, writing the reset command returns the device to reading array data (also applies during Erase Suspend).

### 10.3 Autoselect Command Sequence

The autoselect command sequence allows the host system to access the manufacturer and devices codes, and determine whether or not a sector is protected. [Table 11 on page 32](#) shows the address and data requirements. This method is an alternative to that shown in [Table 2 on page 14](#), which is intended for PROM programmers and requires  $V_{ID}$  on address bit A9.

The autoselect command sequence is initiated by writing two unlock cycles, followed by the autoselect command. The device then enters the autoselect mode, and the system may read at any address any number of times, without initiating another command sequence.

A read cycle at address XX00h retrieves the manufacturer code. A read cycle at address XX01h returns the device code. A read cycle containing a sector address (SA) and the address 02h in word mode (or 04h in byte mode) returns 01h if that sector is protected, or 00h if it is unprotected. Refer to [Table 3 on page 15](#) and [Table 4 on page 16](#) for valid sector addresses.

The system must write the reset command to exit the autoselect mode and return to reading array data.

## 10.4 Enter Secured Silicon Sector/Exit Secured Silicon Sector Command Sequence

The Secured Silicon Sector region provides a secured data area containing a random, sixteen-byte electronic serial number (ESN). The system can access the Secured Silicon Sector region by issuing the three-cycle Enter Secured Silicon Sector command sequence. The device continues to access the Secured Silicon Sector region until the system issues the four-cycle Exit Secured Silicon Sector command sequence. The Exit Secured Silicon Sector command sequence returns the device to normal operation. [Table 11](#) shows the addresses and data requirements for both command sequences. Note that the unlock bypass mode is not available when the device enters the Secured Silicon Sector. For further information, see [Section 8. Secured Silicon Sector Flash Memory Region on page 22](#).

## 10.5 Word/Byte Program Command Sequence

The system may program the device by word or byte, depending on the state of the BYTE# pin. Programming is a four-bus-cycle operation. The program command sequence is initiated by writing two unlock write cycles, followed by the program set-up command. The program address and data are written next, which in turn initiate the Embedded Program algorithm. The system is *not* required to provide further controls or timings. The device automatically generates the program pulses and verifies the programmed cell margin. [Table 11 on page 32](#) shows the address and data requirements for the byte program command sequence.

When the Embedded Program algorithm is complete, the device then returns to reading array data and addresses are no longer latched. The system can determine the status of the program operation by using DQ7, DQ6, or RY/BY#. See [Section 12. Write Operation Status on page 34](#) for information on these status bits.

Any commands written to the device during the Embedded Program Algorithm are ignored. Note that a **hardware reset** immediately terminates the programming operation. The Byte Program command sequence should be reinitiated once the device has reset to reading array data, to ensure data integrity.

Programming is allowed in any sequence and across sector boundaries. **A bit cannot be programmed from a 0 back to a 1.** Attempting to do so may halt the operation and set DQ5 to 1, or cause the Data# Polling algorithm to indicate the operation was successful. However, a succeeding read will show that the data is still 0. Only erase operations can convert a 0 to a 1.

## 10.6 Unlock Bypass Command Sequence

The unlock bypass feature allows the system to program bytes or words to the device faster than using the standard program command sequence. The unlock bypass command sequence is initiated by first writing two unlock cycles. This is followed by a third write cycle containing the unlock bypass command, 20h. The device then enters the unlock bypass mode. A two-cycle unlock bypass program command sequence is all that is required to program in this mode. The first cycle in this sequence contains the unlock bypass program command, A0h; the second cycle contains the program address and data. Additional data is programmed in the same manner. This mode dispenses with the initial two unlock cycles required in the standard program command sequence, resulting in faster total programming time. [Table 11 on page 32](#) shows the requirements for the command sequence.

During the unlock bypass mode, only the Unlock Bypass Program and Unlock Bypass Reset commands are valid. To exit the unlock bypass mode, the system must issue the two-cycle unlock bypass reset command sequence. The first cycle must contain the data 90h; the second cycle the data F0h. Addresses are don't care for both cycles. The device then returns to reading array data.

[Figure 4 on page 29](#) illustrates the algorithm for the program operation. See [Section 18.4 Erase/Program Operations on page 45](#) for parameters, and to [Figure 16 on page 46](#) for timing diagrams.

Figure 4. Program Operation

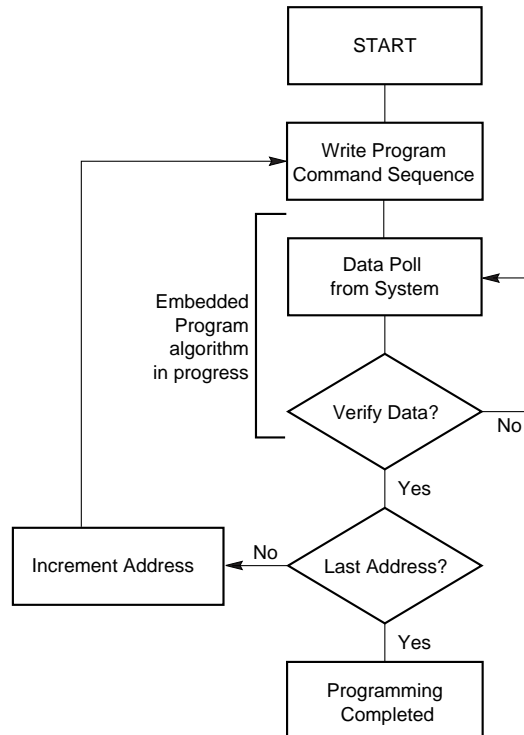

### 10.7 Chip Erase Command Sequence

Chip erase is a six bus cycle operation. The chip erase command sequence is initiated by writing two unlock cycles, followed by a set-up command. Two additional unlock write cycles are then followed by the chip erase command, which in turn invokes the Embedded Erase algorithm. The device does *not* require the system to preprogram prior to erase. The Embedded Erase algorithm automatically preprograms and verifies the entire memory for an all zero data pattern prior to electrical erase. The system is not required to provide any controls or timings during these operations. [Table 11 on page 32](#) shows the address and data requirements for the chip erase command sequence.

Any commands written to the chip during the Embedded Erase algorithm are ignored. Note that a **hardware reset** during the chip erase operation immediately terminates the operation. The Chip Erase command sequence should be reinitiated once the device has returned to reading array data, to ensure data integrity.

The system can determine the status of the erase operation by using DQ7, DQ6, DQ2, or RY/BY#. See [Section 12. Write Operation Status on page 34](#) for information on these status bits. When the Embedded Erase algorithm is complete, the device returns to reading array data and addresses are no longer latched.

[Figure 5 on page 31](#) illustrates the algorithm for the erase operation. See [Section 18.4 Erase/Program Operations on page 45](#) for parameters, and [Figure 17 on page 46](#) for timing diagrams.

**Note**

14. See [Table 11 on page 32](#) for program command sequence.

## 10.8 Sector Erase Command Sequence

Sector erase is a six bus cycle operation. The sector erase command sequence is initiated by writing two unlock cycles, followed by a set-up command. Two additional unlock write cycles are then followed by the address of the sector to be erased, and the sector erase command. [Table 11 on page 32](#) shows the address and data requirements for the sector erase command sequence.

The device does *not* require the system to preprogram the memory prior to erase. The Embedded Erase algorithm automatically programs and verifies the sector for an all zero data pattern prior to electrical erase. The system is not required to provide any controls or timings during these operations.

After the command sequence is written, a sector erase time-out of 50  $\mu$ s begins. During the time-out period, additional sector addresses and sector erase commands may be written. Loading the sector erase buffer may be done in any sequence, and the number of sectors may be from one sector to all sectors. The time between these additional cycles must be less than 50  $\mu$ s, otherwise the last address and command might not be accepted, and erasure may begin. It is recommended that processor interrupts be disabled during this time to ensure all commands are accepted. The interrupts can be re-enabled after the last Sector Erase command is written. If the time between additional sector erase commands can be assumed to be less than 50  $\mu$ s, the system need not monitor DQ3. **Any command other than Sector Erase or Erase Suspend during the time-out period resets the device to reading array data.** The system must rewrite the command sequence and any additional sector addresses and commands.

The system can monitor DQ3 to determine if the sector erase timer has timed out. (See [Section 12.7 DQ3: Sector Erase Timer on page 38](#).) The time-out begins from the rising edge of the final WE# pulse in the command sequence.

Once the sector erase operation has begun, only the Erase Suspend command is valid. All other commands are ignored. Note that a **hardware reset** during the sector erase operation immediately terminates the operation. The Sector Erase command sequence should be reinitiated once the device has returned to reading array data, to ensure data integrity.

When the Embedded Erase algorithm is complete, the device returns to reading array data and addresses are no longer latched. The system can determine the status of the erase operation by using DQ7, DQ6, DQ2, or RY/BY#. (Refer to [Section 12. Write Operation Status on page 34](#) for information on these status bits.)

[Figure 5 on page 31](#) illustrates the algorithm for the erase operation. Refer to [Section 18.4 Erase/Program Operations on page 45](#) for parameters, and to [Figure 17 on page 46](#) for timing diagrams.

## 10.9 Erase Suspend/Erase Resume Commands

The Erase Suspend command allows the system to interrupt a sector erase operation and then read data from, or program data to, any sector not selected for erasure. This command is valid only during the sector erase operation, including the 50  $\mu$ s time-out period during the sector erase command sequence. The Erase Suspend command is ignored if written during the chip erase operation or Embedded Program algorithm. Writing the Erase Suspend command during the Sector Erase time-out immediately terminates the time-out period and suspends the erase operation. Addresses are *don't-cares* when writing the Erase Suspend command.

When the Erase Suspend command is written during a sector erase operation, the device requires a maximum of 35  $\mu$ s to suspend the erase operation. However, when the Erase Suspend command is written during the sector erase time-out, the device immediately terminates the time-out period and suspends the erase operation.

After the erase operation has been suspended, the system can read array data from or program data to any sector not selected for erasure. (The device “erase suspends” all sectors selected for erasure.) Normal read and write timings and command definitions apply. Reading at any address within erase-suspended sectors produces status data on DQ7–DQ0. The system can use DQ7, or DQ6 and DQ2 together, to determine if a sector is actively erasing or is erase-suspended. See [Section 12. Write Operation Status on page 34](#) for information on these status bits.

After an erase-suspended program operation is complete, the system can once again read array data within non-suspended sectors. The system can determine the status of the program operation using the DQ7 or DQ6 status bits, just as in the standard program operation. See [Section 12. Write Operation Status on page 34](#) for more information.

The system may also write the autoselect command sequence when the device is in the Erase Suspend mode. The device allows reading autoselect codes even at addresses within erasing sectors, since the codes are not stored in the memory array. When the device exits the autoselect mode, the device reverts to the Erase Suspend mode, and is ready for another valid operation. See [Section 10.3 Autoselect Command Sequence on page 27](#) for more information.

The system must write the Erase Resume command (address bits are *don't care*) to exit the erase suspend mode and continue the sector erase operation. Further writes of the Resume command are ignored. Another Erase Suspend command can be written after the device has resumed erasing.

**Figure 5. Erase Operation**

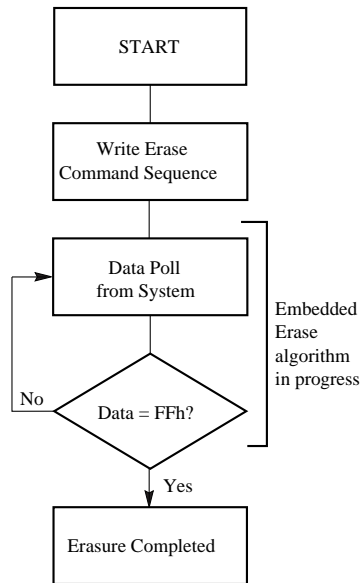

**Notes**

- 15. See [Table 11 on page 32](#) for erase command sequence.
- 16. See [Section 12.7 DQ3: Sector Erase Timer on page 38](#) for more information.

## 11. Command Definitions

Table 11. S29AS016J Command Definitions (Word Mode)

Command Sequence <sup>[17]</sup>		Cycles	Bus Cycles <sup>[Notes 18 through 21]</sup>											
			First		Second		Third		Fourth		Fifth		Sixth	
Read <sup>[22]</sup>		1	RA	RD										
Reset <sup>[23]</sup>		1	XXX	F0										
Autoselect <sup>[24]</sup>	Manufacturer ID	4	555	AA	2AA	55	555	90	X00	01				
	Device ID, Top Boot Block	6	555	AA	2AA	55	555	90	X01	227E	X0E	2203	X0F	2204
	Device ID, Bottom Boot Block	6	555	AA	2AA	55	555	90	X01	227E	X0E	2203	X0F	2203
	Secured Silicon Sector Factory Protect, Top Boot <sup>[25]</sup>	4	555	AA	2AA	55	555	90	X03	0089/0009				
	Secured Silicon Sector Factory Protect, Bottom Boot <sup>[25]</sup>	4	555	AA	2AA	55	555	90	X03	0091/0011				
	Sector Group Protect Verify <sup>[26]</sup>	4	555	AA	2AA	55	555	90	(SA)X02	XX00/XX01				
Enter Secured Silicon Sector		3	555	AA	2AA	55	555	88						
Exit Secured Silicon Sector		4	555	AA	2AA	55	555	90	XXX	00				
CFI Query <sup>[27]</sup>		1	55	98										
Program		4	555	AA	2AA	55	555	A0	PA	PD				
Unlock Bypass		3	555	AA	2AA	55	555	20						
Unlock Bypass Program <sup>[28]</sup>		2	XXX	A0	PA	PD								
Unlock Bypass Reset <sup>[29]</sup>		2	XXX	90	XXX	F0								
Chip Erase		6	555	AA	2AA	55	555	80	555	AA	2AA	55	555	10
Sector Erase		6	555	AA	2AA	55	555	80	555	AA	2AA	55	SA	30
Erase Suspend <sup>[30]</sup>		1	XXX	B0										
Erase Resume <sup>[31]</sup>		1	XXX	30										

**Notes**

- 17. See Table 1 on page 11 for description of bus operations.
- 18. All values are in hexadecimal.
- 19. Except for the read cycle and the fourth cycle of the autoselect command sequence, all bus cycles are write cycles.
- 20. Data bits DQ15–DQ8 are don't cares for unlock and command cycles.
- 21. Address bits A19–A11 are don't cares for unlock and command cycles, unless SA or PA required.
- 22. No unlock or command cycles required when reading array data.
- 23. The Reset command is required to return to reading array data when device is in the autoselect mode, or if DQ5 goes high (while the device is providing status data).
- 24. The fourth cycle of the autoselect command sequence is a read cycle.
- 25. For top boot, 89h = factory locked, 09h = not factory locked. For bottom boot, 91h = factory locked, 11h = not factory locked.
- 26. The data is 00h for an unprotected sector and 01h for a protected sector. See "Autoselect Command Sequence" for more information.
- 27. Command is valid when device is ready to read array data or when device is in autoselect mode.
- 28. The Unlock Bypass command is required prior to the Unlock Bypass Program command.
- 29. The Unlock Bypass Reset command is required to return to reading array data when the device is in the unlock bypass mode. F0 is also acceptable.
- 30. The system may read and program in non-erasing sectors, or enter the autoselect mode, when in the Erase Suspend mode. The Erase Suspend command is valid only during a sector erase operation.
- 31. The Erase Resume command is valid only during the Erase Suspend mode.

**Legend**

X = Don't care  
 RA = Address of the memory location to be read.  
 RD = Data read from location RA during read operation.  
 PA = Address of the memory location to be programmed. Addresses latch on the falling edge of the WE# or CE# pulse, whichever happens later.

PD = Data to be programmed at location PA. Data latches on the rising edge of WE# or CE# pulse, whichever happens first.  
 SA = Address of the sector to be verified (in autoselect mode) or erased. Address bits A19–A12 uniquely select any sector.

Table 12. S29AS016J Command Definitions (Byte Mode)

Command Sequence <sup>[32]</sup>		Cycles	Bus Cycles <sup>[Notes 33 through 36]</sup>											
			First		Second		Third		Fourth		Fifth		Sixth	
Read <sup>[37]</sup>		1	RA	RD										
Reset <sup>[38]</sup>		1	XXX	F0										
Autoselect <sup>[39]</sup>	Manufacturer ID	4	AAA	AA	555	55	AAA	90	X00	01				
	Device ID, Top Boot Block	6	AAA	AA	555	55	AAA	90	X02	7E	X1C	03	X1E	04
	Device ID, Bottom Boot Block	6	AAA	AA	555	55	AAA	90	X02	7E	X1C	03	X1E	03
	Secured Silicon Sector Factory Protect, Top Boot <sup>[40]</sup>	4	AAA	AA	555	55	AAA	90	X06	89/09				
	Secured Silicon Sector Factory Protect, Bottom Boot <sup>[40]</sup>	4	AAA	AA	555	55	AAA	90	X06	91/11				
	Sector Group Protect Verify <sup>[41]</sup>	4	AAA	AA	555	55	AAA	90	(SA)X04	00/01				
Enter Secured Silicon Sector		3	AAA	AA	555	55	AAA	88						
Exit Secured Silicon Sector		4	AAA	AA	555	55	AAA	90	XXX	00				
CFI Query <sup>[42]</sup>		1	AA	98										
Program		4	AAA	AA	555	55	AAA	A0	PA	PD				
Unlock Bypass		3	AAA	AA	555	55	AAA	20						
Unlock Bypass Program <sup>[43]</sup>		2	XXX	A0	PA	PD								
Unlock Bypass Reset <sup>[44]</sup>		2	XXX	90	XXX	F0								
Chip Erase		6	AAA	AA	555	55	AAA	80	AAA	AA	555	55	AAA	10
Sector Erase		6	AAA	AA	555	55	AAA	80	AAA	AA	555	55	SA	30
Erase Suspend <sup>[45]</sup>		1	XXX	B0										
Erase Resume <sup>[46]</sup>		1	XXX	30										

**Notes**

- 32. See Table 1 on page 11 for description of bus operations.
- 33. All values are in hexadecimal.
- 34. Except for the read cycle and the fourth cycle of the autoselect command sequence, all bus cycles are write cycles.
- 35. Data bits DQ15–DQ8 are don't cares for unlock and command cycles.
- 36. Address bits A19–A11 are don't cares for unlock and command cycles, unless SA or PA required.
- 37. No unlock or command cycles required when reading array data.
- 38. The Reset command is required to return to reading array data when device is in the autoselect mode, or if DQ5 goes high (while the device is providing status data).
- 39. The fourth cycle of the autoselect command sequence is a read cycle.
- 40. For top boot, 89h = factory locked, 09h = not factory locked. For bottom boot, 91h = factory locked, 11h = not factory locked.
- 41. The data is 00h for an unprotected sector and 01h for a protected sector. See "Autoselect Command Sequence" for more information.
- 42. Command is valid when device is ready to read array data or when device is in autoselect mode.
- 43. The Unlock Bypass command is required prior to the Unlock Bypass Program command.
- 44. The Unlock Bypass Reset command is required to return to reading array data when the device is in the unlock bypass mode. F0 is also acceptable.
- 45. The system may read and program in non-erasing sectors, or enter the autoselect mode, when in the Erase Suspend mode. The Erase Suspend command is valid only during a sector erase operation.
- 46. The Erase Resume command is valid only during the Erase Suspend mode.

**Legend**

X = Don't care  
 RA = Address of the memory location to be read.  
 RD = Data read from location RA during read operation.  
 PA = Address of the memory location to be programmed. Addresses latch on the falling edge of the WE# or CE# pulse, whichever happens later.

PD = Data to be programmed at location PA. Data latches on the rising edge of WE# or CE# pulse, whichever happens first.  
 SA = Address of the sector to be verified (in autoselect mode) or erased. Address bits A19–A12 uniquely select any sector.

## 12. Write Operation Status

The device provides several bits to determine the status of a write operation: DQ2, DQ3, DQ5, DQ6, DQ7, and RY/BY#. [Table 13 on page 38](#) and the following subsections describe the functions of these bits. DQ7, RY/BY#, and DQ6 each offer a method for determining whether a program or erase operation is complete or in progress. These three bits are discussed first.

### 12.1 DQ7: Data# Polling

The Data# Polling bit, DQ7, indicates to the host system whether an Embedded Algorithm is in progress or completed, or whether the device is in Erase Suspend. Data# Polling is valid after the rising edge of the final WE# pulse in the program or erase command sequence.

During the Embedded Program algorithm, the device outputs on DQ7 the complement of the datum programmed to DQ7. This DQ7 status also applies to programming during Erase Suspend. When the Embedded Program algorithm is complete, the device outputs the datum programmed to DQ7. The system must provide the program address to read valid status information on DQ7. If a program address falls within a protected sector, Data# Polling on DQ7 is active for approximately 1  $\mu$ s, then the device returns to reading array data.

During the Embedded Erase algorithm, Data# Polling produces a 0 on DQ7. When the Embedded Erase algorithm is complete, or if the device enters the Erase Suspend mode, Data# Polling produces a 1 on DQ7. This is analogous to the complement/true datum output described for the Embedded Program algorithm: the erase function changes all the bits in a sector to 1; prior to this, the device outputs the *complement*, or 0. The system must provide an address within any of the sectors selected for erasure to read valid status information on DQ7.

After an erase command sequence is written, if all sectors selected for erasing are protected, Data# Polling on DQ7 is active for approximately 100  $\mu$ s, then the device returns to reading array data. If not all selected sectors are protected, the Embedded Erase algorithm erases the unprotected sectors, and ignores the selected sectors that are protected.

When the system detects DQ7 has changed from the complement to true data, it can read valid data (at DQ7–DQ0 in byte mode or DQ15–DQ0 in word mode) on the *following* read cycles. This is because DQ7 may change asynchronously with DQ0–DQ6 while Output Enable (OE#) is asserted low. [Figure 18 on page 47](#), illustrates this.

[Table 13 on page 38](#) shows the outputs for Data# Polling on DQ7. [Figure 7 on page 37](#) shows the Data# Polling algorithm.

Figure 6. Data# Polling Algorithm

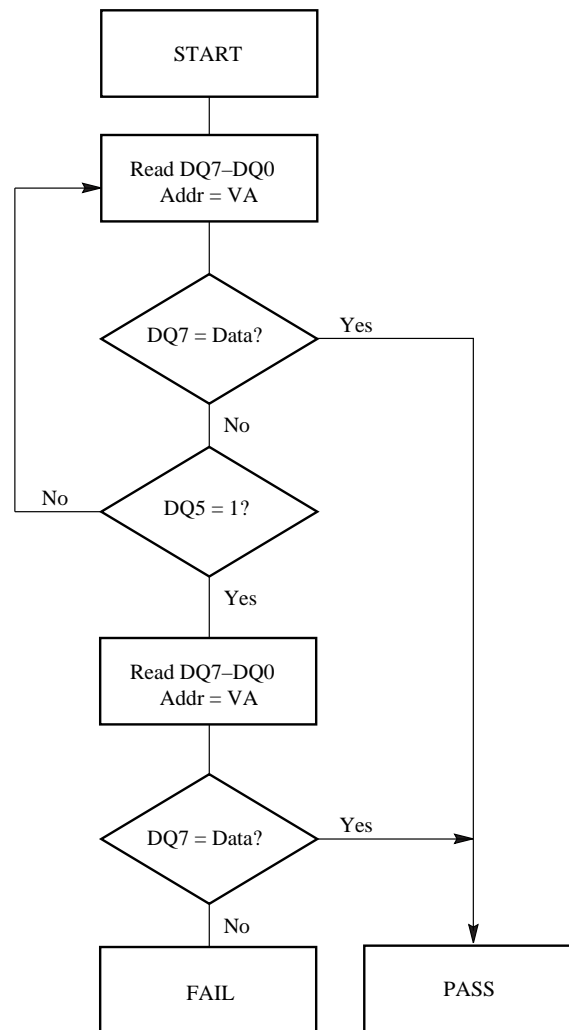

## 12.2 RY/BY#: Ready/Busy#

The RY/BY# is a dedicated, open-drain output pin that indicates whether an Embedded Algorithm is in progress or complete. The RY/BY# status is valid after the rising edge of the final WE# pulse in the command sequence. Since RY/BY# is an open-drain output, several RY/BY# pins can be tied together in parallel with a pull-up resistor to  $V_{CC}$ .

If the output is low (Busy), the device is actively erasing or programming. (This includes programming in the Erase Suspend mode.) If the output is high (Ready), the device is ready to read array data (including during the Erase Suspend mode), or is in the standby mode.

Table 13 on page 38 shows the outputs for RY/BY#. Figures Figure 12 on page 42, Figure 13 on page 43, Figure 16 on page 46, and Figure 17 on page 46 shows RY/BY# for read, reset, program, and erase operations, respectively.

### Notes

47. VA = Valid address for programming. During a sector erase operation, a valid address is an address within any sector selected for erasure. During chip erase, a valid address is any non-protected sector address.

48. DQ7 should be rechecked even if DQ5 = 1 because DQ7 may change simultaneously with DQ5.

## 12.3 DQ6: Toggle Bit I

Toggle Bit I on DQ6 indicates whether an Embedded Program or Erase algorithm is in progress or complete, or whether the device has entered the Erase Suspend mode. Toggle Bit I may be read at any address, and is valid after the rising edge of the final WE# pulse in the command sequence (prior to the program or erase operation), and during the sector erase time-out.

During an Embedded Program or Erase algorithm operation, successive read cycles to any address cause DQ6 to toggle. (The system may use either OE# or CE# to control the read cycles.) When the operation is complete, DQ6 stops toggling.

After an erase command sequence is written, if all sectors selected for erasing are protected, DQ6 toggles for approximately 100  $\mu$ s, then returns to reading array data. If not all selected sectors are protected, the Embedded Erase algorithm erases the unprotected sectors, and ignores the selected sectors that are protected.

The system can use DQ6 and DQ2 together to determine whether a sector is actively erasing or is erase-suspended. When the device is actively erasing (that is, the Embedded Erase algorithm is in progress), DQ6 toggles. When the device enters the Erase Suspend mode, DQ6 stops toggling. However, the system must also use DQ2 to determine which sectors are erasing or erase-suspended. Alternatively, the system can use DQ7 (see [Section 12.1 DQ7: Data# Polling on page 34](#)).

If a program address falls within a protected sector, DQ6 toggles for approximately 1  $\mu$ s after the program command sequence is written, then returns to reading array data.

DQ6 also toggles during the erase-suspend-program mode, and stops toggling once the Embedded Program algorithm is complete.

[Table 13 on page 38](#) shows the outputs for Toggle Bit I on DQ6. [Figure 7 on page 37](#) shows the toggle bit algorithm in flowchart form, and [Section 12.5 Reading Toggle Bits DQ6/DQ2 on page 36](#) explains the algorithm. [Figure 19 on page 47](#) shows the toggle bit timing diagrams. [Figure 20 on page 47](#) shows the differences between DQ2 and DQ6 in graphical form. See also the subsection on [Section 12.4 DQ2: Toggle Bit II on page 36](#).

## 12.4 DQ2: Toggle Bit II

The “Toggle Bit II” on DQ2, when used with DQ6, indicates whether a particular sector is actively erasing (that is, the Embedded Erase algorithm is in progress), or whether that sector is erase-suspended. Toggle Bit II is valid after the rising edge of the final WE# pulse in the command sequence.

DQ2 toggles when the system reads at addresses within those sectors that have been selected for erasure. (The system may use either OE# or CE# to control the read cycles.) But DQ2 cannot distinguish whether the sector is actively erasing or is erase-suspended. DQ6, by comparison, indicates whether the device is actively erasing, or is in Erase Suspend, but cannot distinguish which sectors are selected for erasure. Thus, both status bits are required for sector and mode information. Refer to [Table 13 on page 38](#) to compare outputs for DQ2 and DQ6.

[Figure 7 on page 37](#) shows the toggle bit algorithm in flowchart form, and the section [Section 12.5 Reading Toggle Bits DQ6/DQ2 on page 36](#) explains the algorithm. See also the [Section 12.3 DQ6: Toggle Bit I on page 36](#) subsection. [Figure 19 on page 47](#) shows the toggle bit timing diagram. [Figure 20 on page 47](#) shows the differences between DQ2 and DQ6 in graphical form.

## 12.5 Reading Toggle Bits DQ6/DQ2

Refer to [Figure 7 on page 37](#) for the following discussion. Whenever the system initially begins reading toggle bit status, it must read DQ7–DQ0 at least twice in a row to determine whether a toggle bit is toggling. Typically, the system would note and store the value of the toggle bit after the first read. After the second read, the system would compare the new value of the toggle bit with the first. If the toggle bit is not toggling, the device has completed the program or erase operation. The system can read array data (at DQ7–DQ0 in byte mode or DQ15–DQ0 in word mode) on the following read cycle.

However, if after the initial two read cycles, the system determines that the toggle bit is still toggling, the system also should note whether the value of DQ5 is high (see the section on DQ5). If it is, the system should then determine again whether the toggle bit is toggling, since the toggle bit may have stopped toggling just as DQ5 went high. If the toggle bit is no longer toggling, the device has successfully completed the program or erase operation. If it is still toggling, the device did not complete the operation successfully, and the system must write the reset command to return to reading array data.

The remaining scenario is that the system initially determines that the toggle bit is toggling and DQ5 has not gone high. The system may continue to monitor the toggle bit and DQ5 through successive read cycles, determining the status as described in the previous paragraph. Alternatively, it may choose to perform other system tasks. In this case, the system must start at the beginning of the algorithm when it returns to determine the status of the operation (top of [Figure 7 on page 37](#)).

Figure 7. Toggle Bit Algorithm

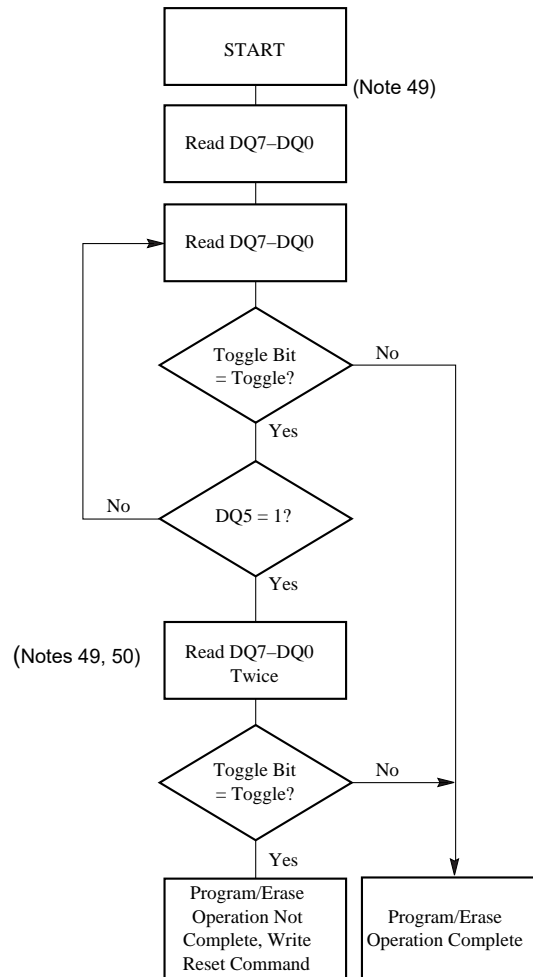

### 12.6 DQ5: Exceeded Timing Limits

DQ5 indicates whether the program or erase time has exceeded a specified internal pulse count limit. Under these conditions DQ5 produces a 1. This is a failure condition that indicates the program or erase cycle was not successfully completed.

The DQ5 failure condition may appear if the system tries to program a 1 to a location that is previously programmed to 0. **Only an erase operation can change a 0 back to a 1.** Under this condition, the device halts the operation, and when the operation has exceeded the timing limits, DQ5 produces a 1.

Under both these conditions, the system must issue the reset command to return the device to reading array data.

**Notes**

- 49. Read toggle bit twice to determine whether or not it is toggling. See text.
- 50. Recheck toggle bit because it may stop toggling as DQ5 changes to 1. See text.

## 12.7 DQ3: Sector Erase Timer

After writing a sector erase command sequence, the system may read DQ3 to determine whether or not an erase operation has begun. (The sector erase timer does not apply to the chip erase command.) If additional sectors are selected for erasure, the entire time-out also applies after each additional sector erase command. When the time-out is complete, DQ3 switches from 0 to 1. The system may ignore DQ3 if the system can guarantee that the time between additional sector erase commands will always be less than 50  $\mu$ s. See also [Section 10.8 Sector Erase Command Sequence on page 30](#).

After the sector erase command sequence is written, the system should read the status on DQ7 (Data# Polling) or DQ6 (Toggle Bit I) to ensure the device has accepted the command sequence, and then read DQ3. If DQ3 is 1, the internally controlled erase cycle has begun; all further commands (other than Erase Suspend) are ignored until the erase operation is complete. If DQ3 is 0, the device will accept additional sector erase commands. To ensure the command has been accepted, the system software should check the status of DQ3 prior to and following each subsequent sector erase command. If DQ3 is high on the second status check, the last command might not have been accepted. [Table 13](#) shows the outputs for DQ3.

**Table 13. Write Operation Status**

Operation		DQ7 <sup>[52]</sup>	DQ6	DQ5 <sup>[51]</sup>	DQ3	DQ2 <sup>[52]</sup>	RY/BY#
Standard Mode	Embedded Program Algorithm	DQ7#	Toggle	0	N/A	No toggle	0
	Embedded Erase Algorithm	0	Toggle	0	1	Toggle	0
Erase Suspend Mode	Reading within Erase Suspended Sector	1	No toggle	0	N/A	Toggle	1
	Reading within Non-Erase Suspended Sector	Data	Data	Data	Data	Data	1
	Erase-Suspend-Program	DQ7#	Toggle	0	N/A	N/A	0

**Notes**

51. DQ5 switches to 1 when an Embedded Program or Embedded Erase operation has exceeded the maximum timing limits. See [DQ5: Exceeded Timing Limits on page 37](#) for more information.

52. DQ7 and DQ2 require a valid address when reading status information. Refer to the appropriate subsection for further details.

### 13. Absolute Maximum Ratings

Storage Temperature Plastic Packages	-65°C to +150°C
Ambient Temperature with Power Applied	-65°C to +125°C
Voltage with Respect to Ground	
$V_{CC}^{[53]}$	-0.5 V to +2.0 V
A9, RESET# <sup>[54]</sup>	-0.5 V to +12.5 V
All other pins <sup>[53]</sup>	-0.5 V to $V_{CC}+0.5$ V
Output Short Circuit Current <sup>[55]</sup>	200 mA

**Notes**

- 53. Minimum DC voltage on input or I/O pins is -0.5 V. During voltage transitions, input or I/O pins may overshoot  $V_{SS}$  to -2.0 V for periods of up to 20 ns. See [Figure 8 on page 39](#). Maximum DC voltage on input or I/O pins is  $V_{CC} + 0.5$  V. During voltage transitions, input or I/O pins may overshoot to  $V_{CC} + 2.0$  V for periods up to 20 ns. See [Figure 9 on page 39](#).
- 54. Minimum DC input voltage on pins A9, OE#, and RESET# is -0.5 V. During voltage transitions, A9 and RESET# may overshoot  $V_{SS}$  to -2.0 V for periods of up to 20 ns. See [Figure 8 on page 39](#). Maximum DC input voltage on pin A9 is +11.0 V which may overshoot to 12.5 V for periods up to 20 ns.
- 55. No more than one output may be shorted to ground at a time. Duration of the short circuit should not be greater than one second.
- 56. Stresses above those listed under Absolute Maximum Ratings may cause permanent damage to the device. This is a stress rating only; functional operation of the device at these or any other conditions above those indicated in the operational sections of this data sheet is not implied. Exposure of the device to absolute maximum rating conditions for extended periods may affect device reliability.

### 14. Operating Ranges

Description		Range
Ambient Temperature ( $T_A$ )	Industrial / Automotive AEC-Q100 Grade 3	-40°C to +85°C
	Industrial Plus / Automotive AEC-Q100 Grade 2	-40°C to +105°C
$V_{CC}$ Supply Voltages	Standard Voltage Range	1.65V to 1.95V

**Note**

- 57. Operating ranges define those limits between which the functionality of the device is guaranteed.

**Figure 8. Maximum Negative Overshoot Waveform**

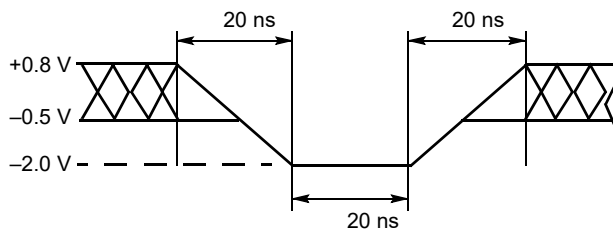

**Figure 9. Maximum Positive Overshoot Waveform**

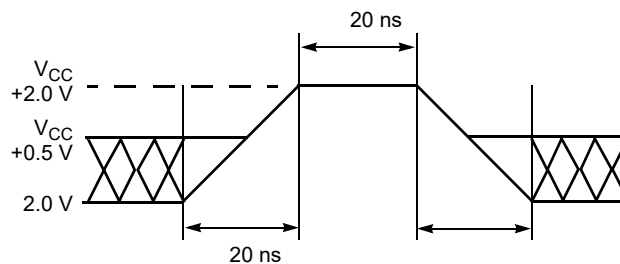

## 15. DC Characteristics

### 15.1 CMOS Compatible

Parameter	Description	Test Conditions	Min	Typ	Max (-40 °C to +85 °C)	Max (-40 °C to +105 °C)	Unit
$I_{LI}$	Input Load Current	$V_{IN} = V_{SS}$ to $V_{CC}$ , $V_{CC} = V_{CC\ max}$			±1.0		μA
$I_{LI}$	WP# Input Load Current	$V_{CC} = V_{CC\ max}$ ; WP# = $V_{SS} \pm 0.2\ V$			-15		
	A9, RESET Input Load Current	$V_{CC} = V_{CC\ max}$ ; A9, RESET = 11V			35		
$I_{LO}$	Output Leakage Current	$V_{OUT} = V_{SS}$ to $V_{CC}$ , $V_{CC} = V_{CC\ max}$			±1.0		
$I_{CC1}$	V <sub>CC</sub> Active Read Current <sup>[58]</sup>	CE# = $V_{IL}$ , OE# = $V_{IH}$ , Byte Mode	5 MHz	8	12		mA
			1 MHz	2	4		
		CE# = $V_{IL}$ , OE# = $V_{IH}$ , Word Mode	5 MHz	8	12		
			1 MHz	2	4		
$I_{CC2}$	V <sub>CC</sub> Active Write Current <sup>[59, 60]</sup>	CE# = $V_{IL}$ , OE# = $V_{IH}$		20	30		mA
$I_{CC3}$	V <sub>CC</sub> Standby Current	CE#, RESET# = $V_{CC} \pm 0.2\ V$		8	30	50	μA
$I_{CC4}$	V <sub>CC</sub> Standby Current During Reset	RESET# = $V_{SS} \pm 0.2\ V$		8	30	50	μA
$I_{CC5}$	Automatic Sleep Mode <sup>[61]</sup>	$V_{IH} = V_{CC} \pm 0.2\ V$ ; $V_{IL} = V_{SS} \pm 0.2\ V$		15	70	100	μA
$V_{IL}$	Input Low Voltage		-0.5		0.3 x V <sub>CC</sub>		V
$V_{IH}$	Input High Voltage		0.7 x V <sub>CC</sub>		V <sub>CC</sub> + 0.3		
$V_{ID}$	Voltage for Autoselect and Temporary Sector Group Unprotect	V <sub>CC</sub> = 1.65 to 1.95 V	9.0		11.0		
$V_{OL}$	Output Low Voltage	$I_{OL} = 2.0\ mA$ , $V_{CC} = V_{CC\ min}$			0.25		
$V_{OH1}$	Output High Voltage	$I_{OH} = -2.0\ mA$ , $V_{CC} = V_{CC\ min}$	0.85 x V <sub>CC</sub>				
$V_{OH2}$		$I_{OH} = -100\ \mu A$ , $V_{CC} = V_{CC\ min}$	V <sub>CC</sub> -0.1				
$V_{LKO}$	Low V <sub>CC</sub> Lock-Out Voltage <sup>[60]</sup>		1.2		1.4		

**Notes**

58. The  $I_{CC}$  current listed is typically less than 1 mA/MHz, with OE# at  $V_{IH}$ .

59.  $I_{CC}$  active while Embedded Erase or Embedded Program is in progress.

60. Not 100% tested.

61. Automatic sleep mode enables the low power mode when addresses remain stable for  $t_{ACC} + 30\ ns$ . Typical sleep mode current is 15 μA.

## 16. Test Conditions

Figure 10. Test Setup

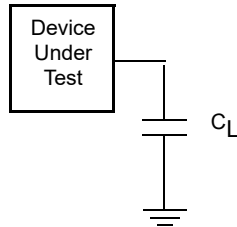

Table 14. Test Specifications

Test Condition	70	Unit
Output Load Capacitance, $C_L$ (including jig capacitance)	100	pF
Input Rise and Fall Times	3	ns
Input Pulse Levels	0.0 – 2.0	V
Input timing measurement reference levels	1.0	
Output timing measurement reference levels	1.0	

## 17. Key to Switching Waveforms

Waveform	Inputs	Outputs
	Steady	
	Changing from H to L	
	Changing from L to H	
	Don't Care, Any Change Permitted	Changing, State Unknown
	Does Not Apply	Center Line is High Impedance State (High-Z)

Figure 11. Input Waveforms and Measurement Levels

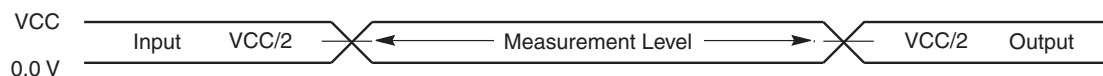

## 18. AC Characteristics

### 18.1 Read Operations

Parameter		Description	Test Setup		Speed Options	Unit
JEDEC	Std				70	
$t_{AVAV}$	$t_{RC}$	Read Cycle Time <sup>[62]</sup>		Min	70	ns
$t_{AVQV}$	$t_{ACC}$	Address to Output Delay	CE# = $V_{IL}$ OE# = $V_{IL}$	Max	70	
$t_{ELQV}$	$t_{CE}$	Chip Enable to Output Delay	OE# = $V_{IL}$	Max	70	
$t_{GLQV}$	$t_{OE}$	Output Enable to Output Delay		Max	25	
$t_{EHQZ}$	$t_{DF}$	Chip Enable to Output High-Z <sup>[62]</sup>		Max	25	
$t_{GHQZ}$	$t_{DF}$	Output Enable to Output High-Z <sup>[62]</sup>		Max	25	
	$t_{OEHL}$	Read		Min	0	
		Toggle and Data# Polling		Min	10	
$t_{AXQX}$	$t_{OH}$	Output Hold Time From Addresses, CE# or OE#, Whichever Occurs First <sup>[62]</sup>		Min	0	

**Notes**

62. Not 100% tested.

63. See Figure 10 on page 41 and Table 14 on page 41 for test specifications.

64.  $t_{RC}$  must be same or longer than 70 ns right before read access to the flash (for devices with model numbers 01 and 02 only).

**Figure 12. Read Operations Timings**

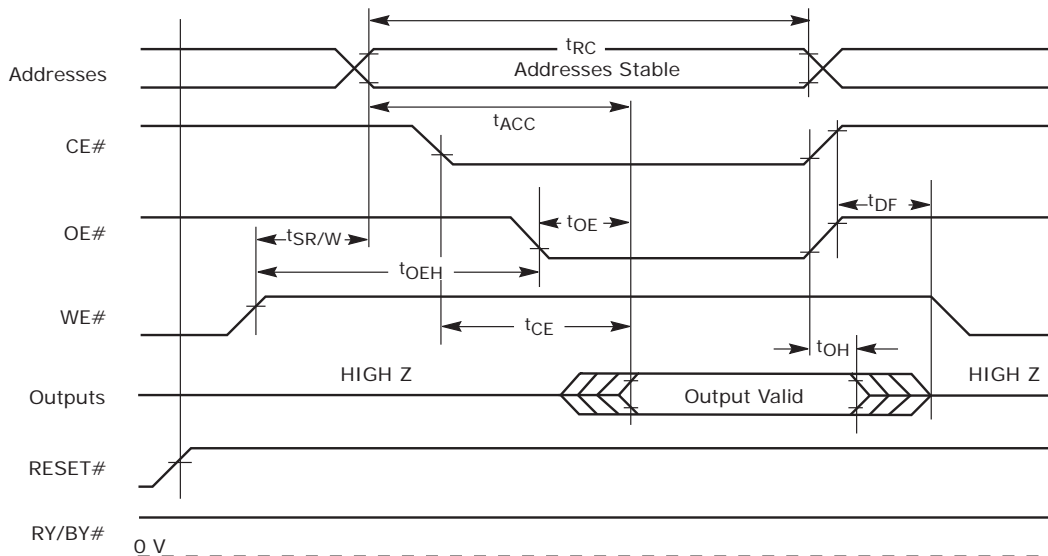

## 18.2 Hardware Reset (RESET#)

Parameter		Description	Test Setup	All Speed Options	Unit
JEDEC	Std				
	$t_{\text{READY}}$	RESET# Pin Low (During Embedded Algorithms) to Read or Write <sup>[65]</sup>	Max	35	$\mu\text{s}$
	$t_{\text{READY}}$	RESET# Pin Low (NOT During Embedded Algorithms) to Read or Write <sup>[65]</sup>	Max	500	ns
	$t_{\text{RP}}$	RESET# Pulse Width	Min	500	
	$t_{\text{RH}}$	RESET# High Time Before Read <sup>[65]</sup>		50	
	$t_{\text{RPD}}$	RESET# Low to Standby Mode		20	$\mu\text{s}$
	$t_{\text{RB}}$	RY/BY# Recovery Time		0	ns

**Notes**  
65. Not 100% tested.

Figure 13. RESET# Timings<sup>[66]</sup>

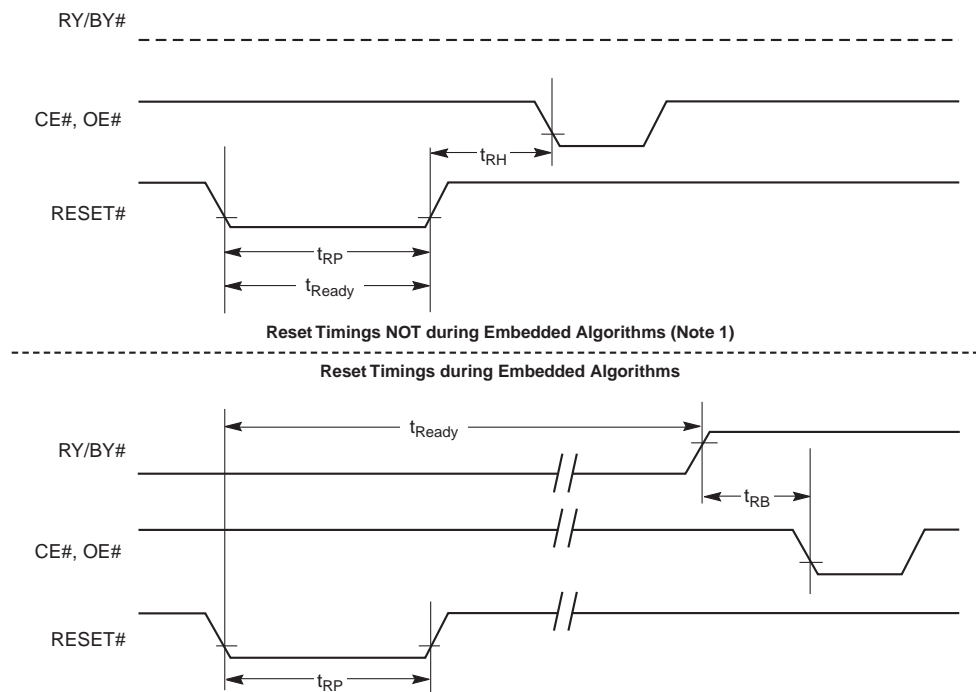

**Note**  
66. CE# should only go low after RESET# has gone high. Keeping CE# low from power up through the first read could cause the first read to retrieve erroneous data.

### 18.3 Word/Byte Configuration (BYTE#)

Parameter		Description		Speed Options	Unit
JEDEC	Std			70	
	$t_{ELFL}/t_{ELFH}$	CE# to BYTE# Switching Low or High	Max	5	ns
	$t_{FLQZ}$	BYTE# Switching Low to Output High-Z	Max	25	
	$t_{FHQV}$	BYTE# Switching High to Output Active	Min	70	

Figure 14. BYTE# Timings for Read Operations

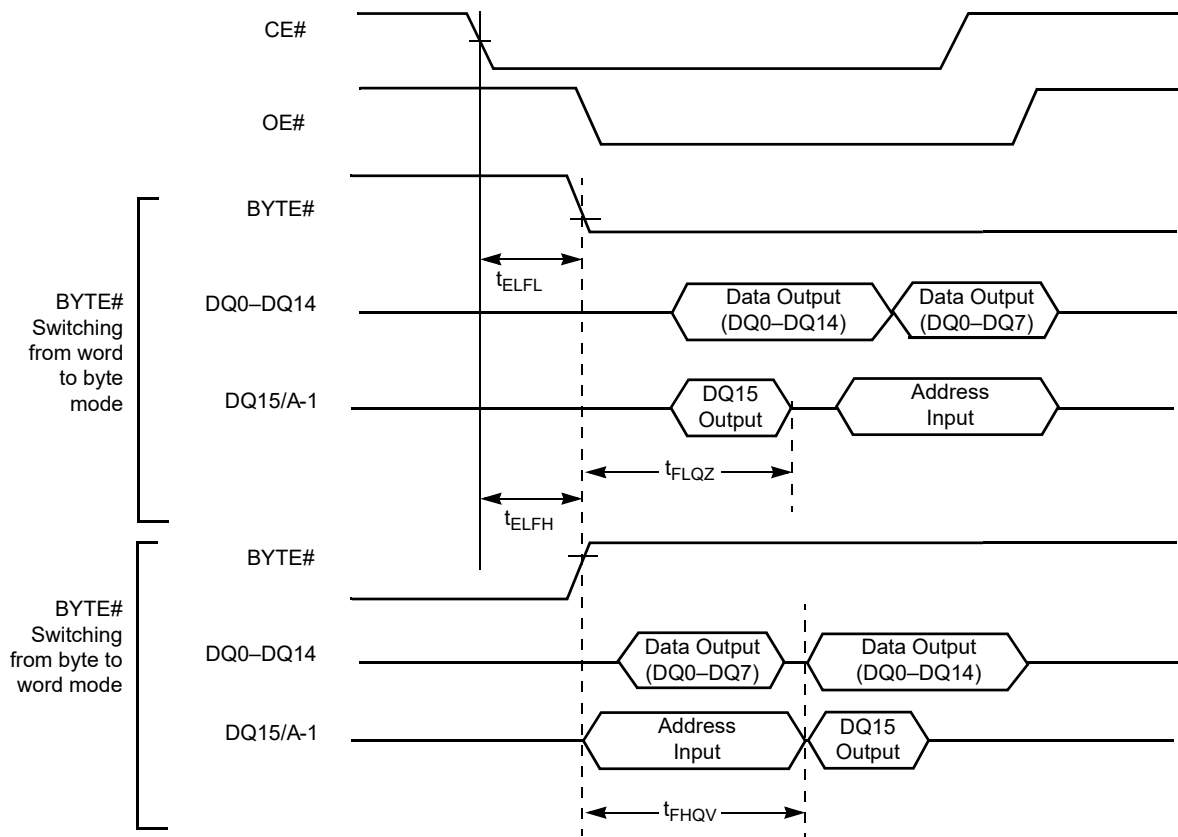
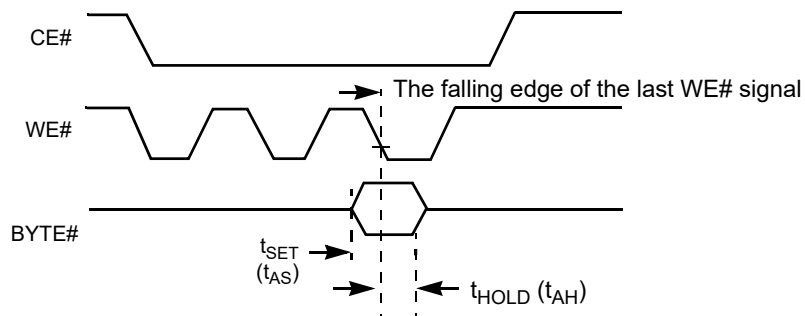

Figure 15. BYTE# Timings for Write Operations



**Note**  
67. Refer to the Erase/Program Operations table for  $t_{AS}$  and  $t_{AH}$  specifications.

## 18.4 Erase/Program Operations

Parameter		Description		Speed Options	Unit
JEDEC	Std			70	
$t_{AVAV}$	$t_{WC}$	Write Cycle Time <sup>[68]</sup>	Min	70	ns
$t_{AVWL}$	$t_{AS}$	Address Setup Time		0	
$t_{WLAX}$	$t_{AH}$	Address Hold Time		45	
$t_{DVWH}$	$t_{DS}$	Data Setup Time		35	
$t_{WHDX}$	$t_{DH}$	Data Hold Time		0	
	$t_{OES}$	Output Enable Setup Time		0	
$t_{GHWL}$	$t_{GHWL}$	Read Recovery Time Before Write (OE# High to WE# Low)		0	
$t_{ELWL}$	$t_{CS}$	CE# Setup Time		0	
$t_{WHEH}$	$t_{CH}$	CE# Hold Time		0	
$t_{WLWH}$	$t_{WP}$	Write Pulse Width		35	
$t_{WHWL}$	$t_{WPH}$	Write Pulse Width High		20	
	$t_{SR/W}$	Latency Between Read and Write Operations		Min	
$t_{WHWH1}$	$t_{WHWH1}$	Programming Operation <sup>[69]</sup>	Typ	6	$\mu$ s
		Byte		6	
$t_{WHWH2}$	$t_{WHWH2}$	Sector Erase Operation <sup>[69]</sup>		0.5	sec
	$t_{VCS}$	$V_{CC}$ Setup Time <sup>[68]</sup>	Min	50	$\mu$ s
	$t_{RB}$	Recovery Time from RY/BY#		0	ns
	$t_{BUSY}$	Program/Erase Valid to RY/BY# Delay	Max	90	

**Notes**

68. Not 100% tested.

69. See [Section 19. Erase and Programming Performance](#) on page 51 for more information.

Figure 16. Program Operation Timings<sup>[70, 71]</sup>

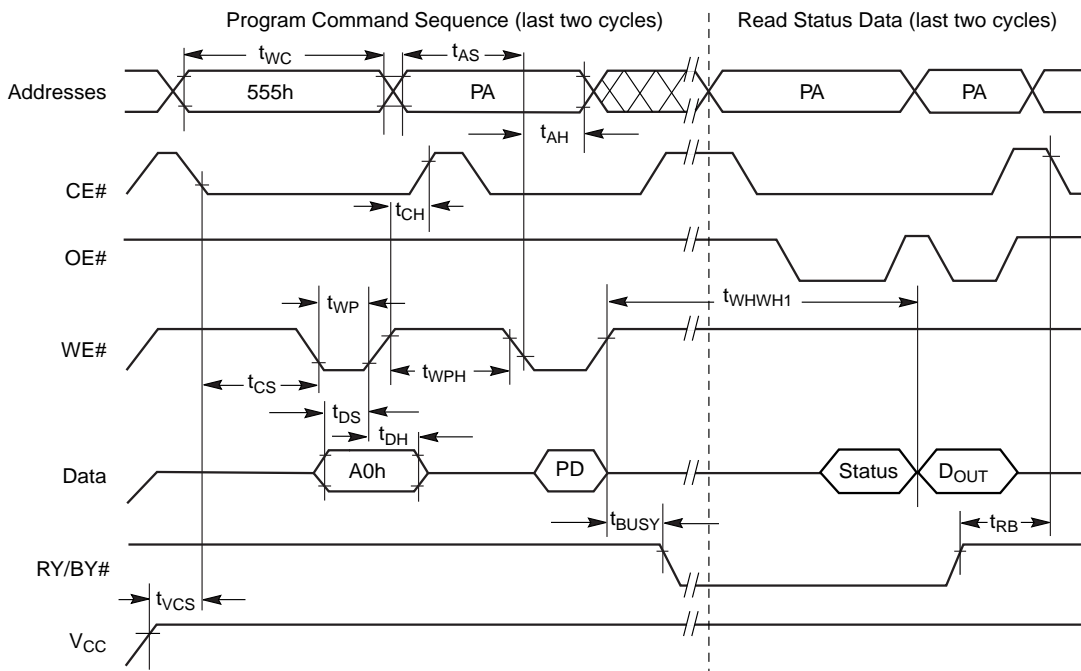
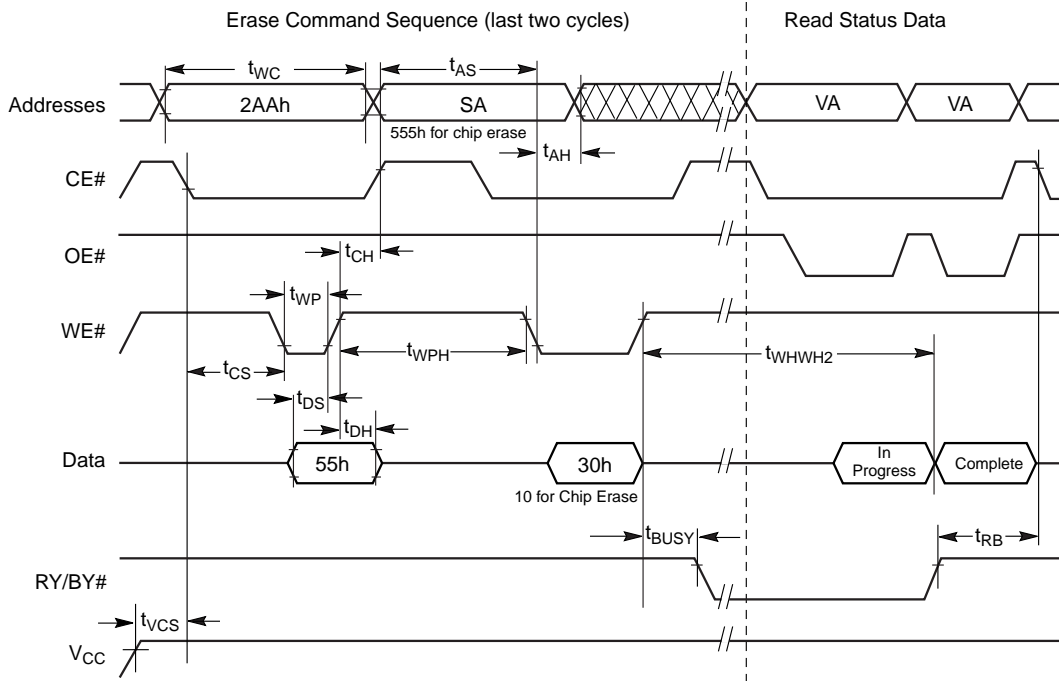

Figure 17. Chip/Sector Erase Operation Timings<sup>[71, 72]</sup>



Notes

70. PA = program address, PD = program data, D<sub>OUT</sub> is the true data at the program address.

71. Illustration shows device in word mode.

72. SA = sector address (for Sector Erase), VA = Valid Address for reading status data (see Section 12. Write Operation Status on page 34).

**Figure 18. Data# Polling Timings (During Embedded Algorithms)<sup>[73]</sup>**

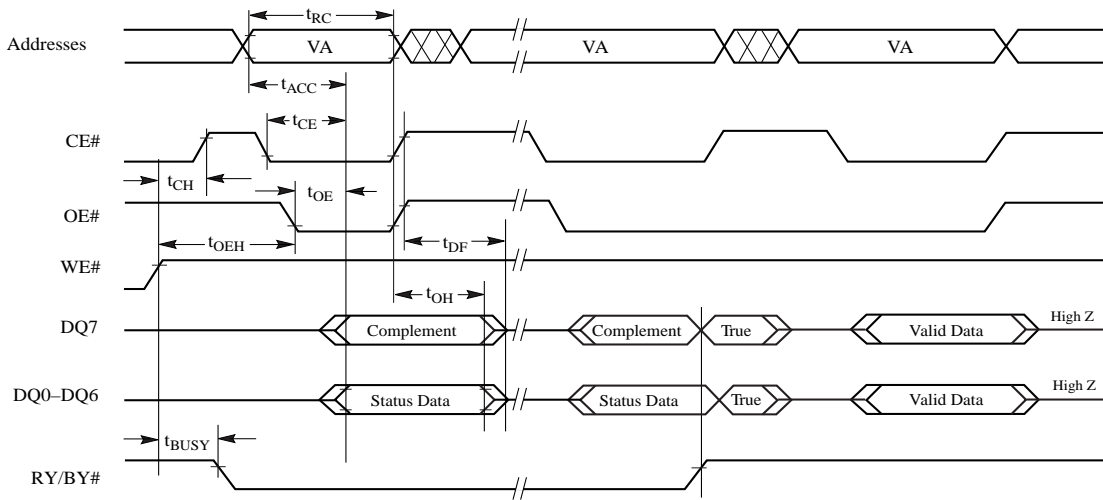

**Figure 19. Toggle Bit Timings (During Embedded Algorithms)<sup>[74]</sup>**

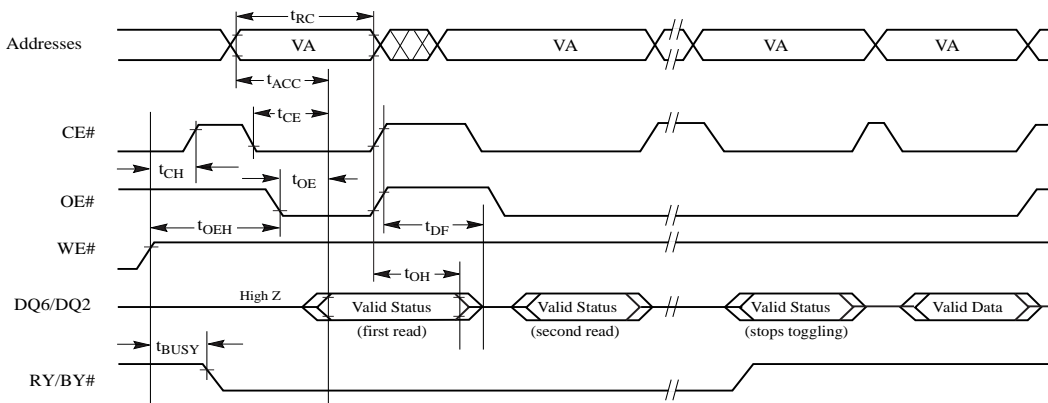

**Figure 20. DQ2 vs. DQ6 for Erase and Erase Suspend Operations<sup>[75]</sup>**

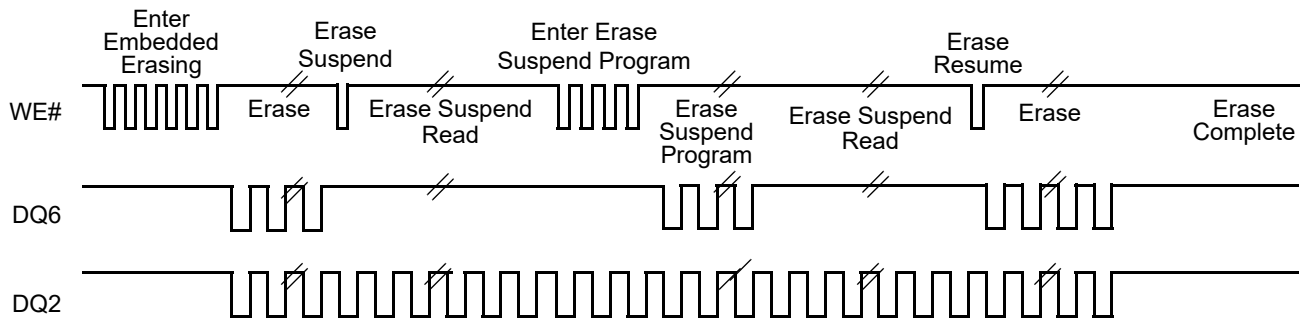

**Notes**

73. VA = Valid address. Illustration shows first status cycle after command sequence, last status read cycle, and array data read cycle.

74. VA = Valid address; not required for DQ6. Illustration shows first two status cycle after command sequence, last status read cycle, and array data read cycle.

75. The system may use CE# or OE# to toggle DQ2 and DQ6. DQ2 toggles only when read at an address within an erase-suspended sector.

### 18.5 Temporary Sector Group Unprotect

Parameter		Description		All Speed Options	Unit
JEDEC	Std				
	$t_{VIDR}$	$V_{ID}$ Rise and Fall Time <sup>[76]</sup>	Min	500	ns
	$t_{RSP}$	RESET# Setup Time for Temporary Sector Group Unprotect	Min	4	$\mu$ s

**Note**  
76. Not 100% tested.

**Figure 21. Temporary Sector Group Unprotect/Timing Diagram**

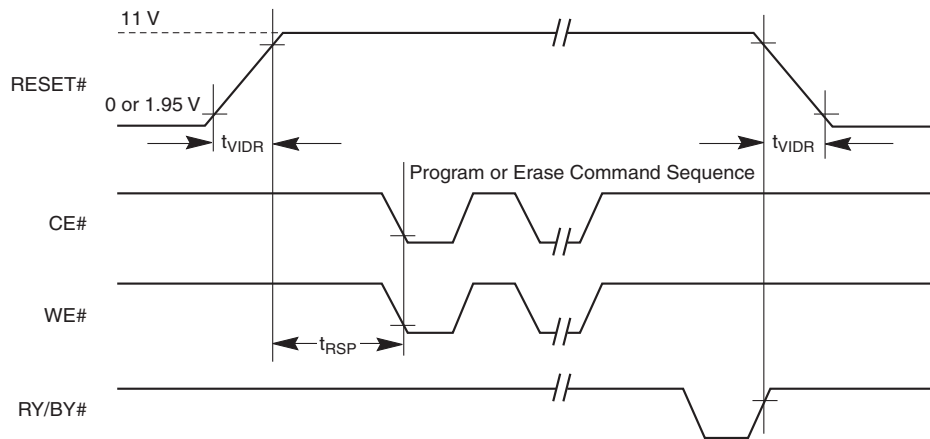

**Figure 22. Sector Group Protect/Unprotect Timing Diagram<sup>[77]</sup>**

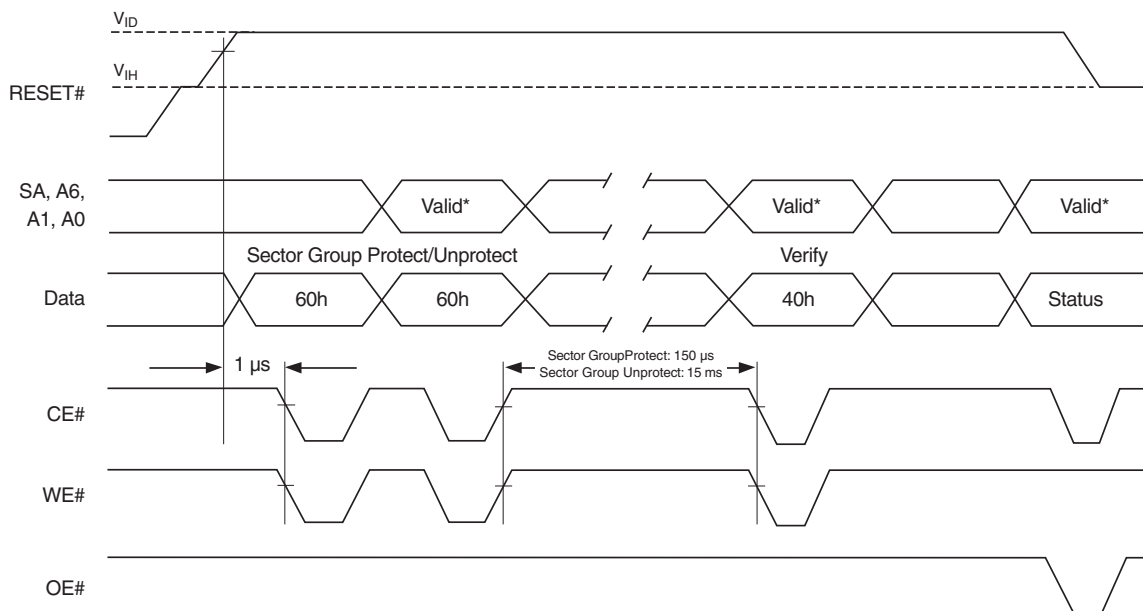

**Note**  
77. For sector group protect, A6 = 0, A1 = 1, A0 = 0. For sector group unprotect, A6 = 1, A1 = 1, A0 = 0.

## 18.6 Alternate CE# Controlled Erase/Program Operations

Parameter		Description		Speed Options	Unit
JEDEC	Std			70	
$t_{AVAV}$	$t_{WC}$	Write Cycle Time <sup>[78]</sup>	Min	70	ns
$t_{AVEL}$	$t_{AS}$	Address Setup Time	Min	0	ns
$t_{ELAX}$	$t_{AH}$	Address Hold Time	Min	45	ns
$t_{DVEH}$	$t_{DS}$	Data Setup Time	Min	35	ns
$t_{EHDX}$	$t_{DH}$	Data Hold Time	Min	0	ns
	$t_{OES}$	Output Enable Setup Time	Min	0	ns
$t_{GHEL}$	$t_{GHEL}$	Read Recovery Time Before Write (OE# High to WE# Low)	Min	0	ns
$t_{WLEL}$	$t_{WS}$	WE# Setup Time	Min	0	ns
$t_{EHWH}$	$t_{WH}$	WE# Hold Time	Min	0	ns
$t_{ELEH}$	$t_{CP}$	CE# Pulse Width	Min	35	ns
$t_{EHEL}$	$t_{CPH}$	CE# Pulse Width High	Min	20	ns
	$t_{SRW}$	Latency Between Read and Write Operations	Min	20	ns
$t_{WHWH1}$	$t_{WHWH1}$	Programming Operation <sup>[79]</sup>	Byte	Typ	6
			Word	Typ	6
$t_{WHWH2}$	$t_{WHWH2}$	Sector Erase Operation <sup>[79]</sup>	Typ	0.5	sec

**Notes**

78. Not 100% tested.

79. See [Erase and Programming Performance](#) on page 51 for more information.

Figure 23. Alternate CE# Controlled Write Operation Timings<sup>[80, 81, 82]</sup>

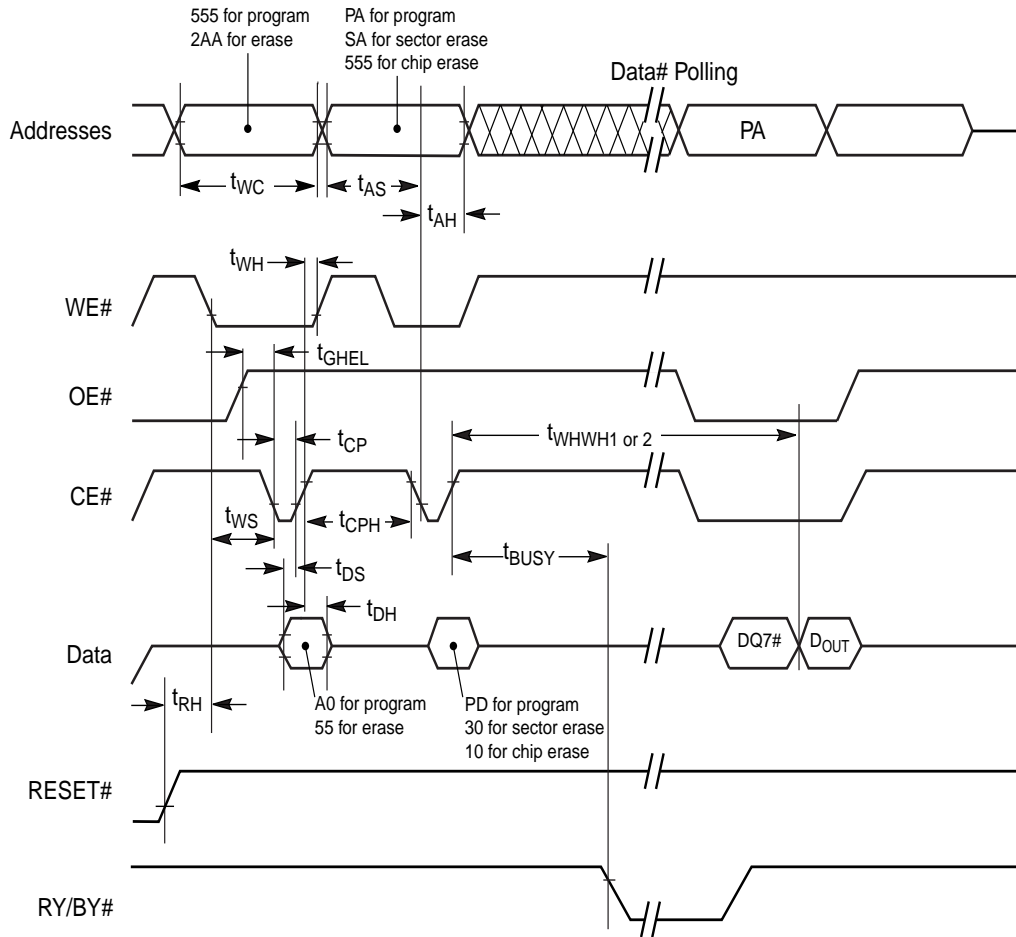

**Notes**

- 80. PA = program address, PD = program data, DQ7# = complement of the data written to the device, D<sub>OUT</sub> = data written to the device.
- 81. Figure indicates the last two bus cycles of the command sequence.
- 82. Word mode address used as an example.

## 19. Erase and Programming Performance

Parameter		Typ <sup>[83]</sup>	Max <sup>[84]</sup>	Unit	Comments
Sector Erase Time		0.5	10	s	Excludes 00h programming prior to erasure <sup>[86]</sup>
Chip Erase Time		19.5		s	
Byte Programming Time		6		μs	Excludes system level overhead <sup>[87]</sup>
Word Programming Time		6	150	μs	
Chip Programming Time <sup>[85]</sup>	Byte Mode	20	160	s	
	Word Mode	14	120	s	

**Notes**

83. Typical program and erase times assume the following conditions: 25°C, V<sub>CC</sub> = 1.8 V, 100,000 cycles, checkerboard data pattern.

84. Under worst case conditions of 90°C, V<sub>CC</sub> = 1.65 V, 1,000,000 cycles.

85. The typical chip programming time is considerably less than the maximum chip programming time listed, since most bytes program faster than the maximum program times listed.

86. In the pre-programming step of the Embedded Erase algorithm, all bytes are programmed to 00h before erasure.

87. System-level overhead is the time required to execute the two- or four-bus-cycle sequence for the program command. See [Table 11 on page 32](#) for further information on command definitions.

88. The device has a minimum erase and program cycle endurance of 100,000 cycles per sector.

## 20. Package Pin Capacitance

Parameter Symbol	Parameter Description	Test Setup	Package	Typ	Max	Unit
C <sub>IN</sub>	Input Capacitance	V <sub>IN</sub> = 0	TSOP	4.0	6.0	pF
			BGA	4.2	5.0	
C <sub>OUT</sub>	Output Capacitance	V <sub>OUT</sub> = 0	TSOP	4.5	5.5	
			BGA	5.4	6.5	
C <sub>IN2</sub>	Control Pin Capacitance	V <sub>IN</sub> = 0	TSOP	5	6.5	
			BGA	3.9	4.7	
C <sub>IN3</sub>	WP# Pin Capacitance	V <sub>IN</sub> = 0	TSOP	8.5	10.0	
			BGA	8.5	10.0	

**Notes**

89. Sampled, not 100% tested.

90. Test conditions T<sub>A</sub> = 25°C, f = 1.0 MHz.

## 21. Physical Dimensions

Figure 24. TS 048 – 48-Pin Standard TSOP (51-85183)

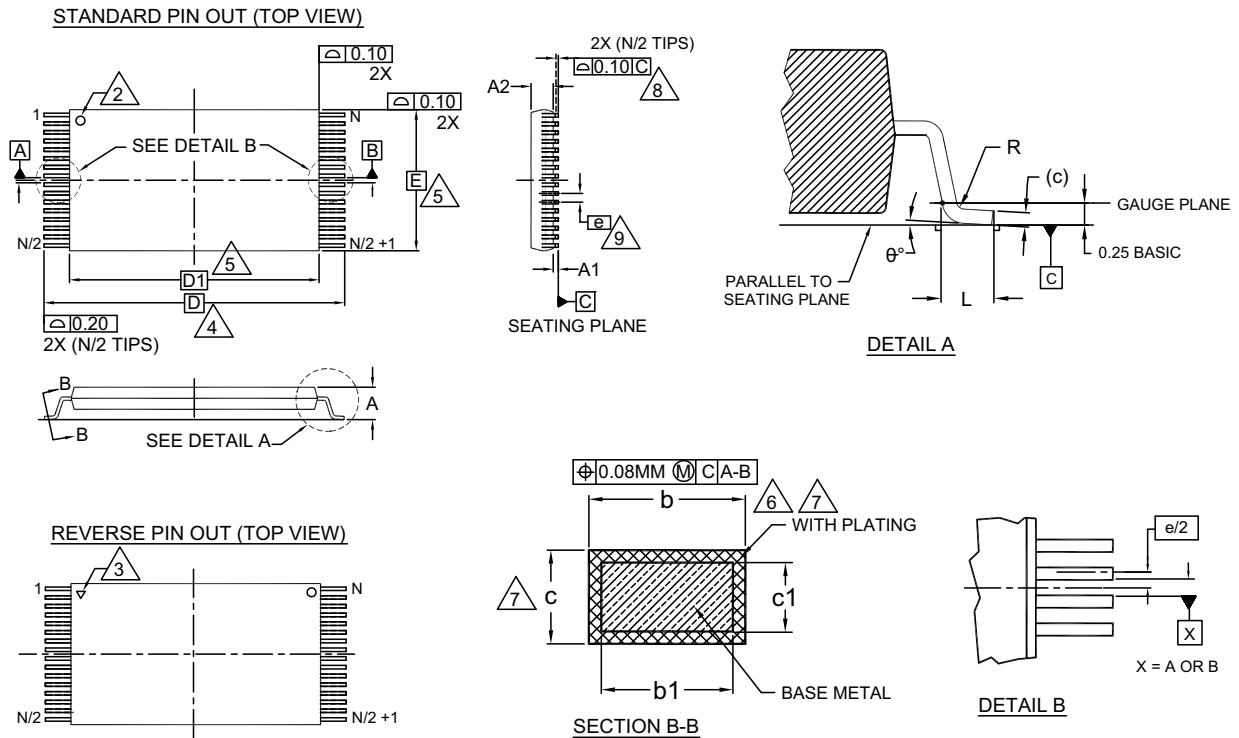

SYMBOL	DIMENSIONS		
	MIN.	NOM.	MAX.
A	—	—	1.20
A1	0.05	—	0.15
A2	0.95	1.00	1.05
b1	0.17	0.20	0.23
b	0.17	0.22	0.27
c1	0.10	—	0.16
c	0.10	—	0.21
D	20.00 BASIC		
D1	18.40 BASIC		
E	12.00 BASIC		
e	0.50 BASIC		
L	0.50	0.60	0.70
θ	0°	—	8
R	0.08	—	0.20
N	48		

**NOTES:**

- 1. DIMENSIONS ARE IN MILLIMETERS (mm).
- 2. PIN 1 IDENTIFIER FOR STANDARD PIN OUT (DIE UP).
- 3. PIN 1 IDENTIFIER FOR REVERSE PIN OUT (DIE DOWN); INK OR LASER MARK.
- 4. TO BE DETERMINED AT THE SEATING PLANE [-C-]. THE SEATING PLANE IS DEFINED AS THE PLANE OF CONTACT THAT IS MADE WHEN THE PACKAGE LEADS ARE ALLOWED TO REST FREELY ON A FLAT HORIZONTAL SURFACE.
- 5. DIMENSIONS D1 AND E DO NOT INCLUDE MOLD PROTRUSION. ALLOWABLE MOLD PROTRUSION ON E IS 0.15mm PER SIDE AND ON D1 IS 0.25mm PER SIDE.
- 6. DIMENSION b DOES NOT INCLUDE DAMBAR PROTRUSION. ALLOWABLE DAMBAR PROTRUSION SHALL BE 0.08mm TOTAL IN EXCESS OF b DIMENSION AT MAX. MATERIAL CONDITION. DAMBAR CANNOT BE LOCATED ON LOWER RADIUS OR THE FOOT. MINIMUM SPACE BETWEEN PROTRUSION AND AN ADJACENT LEAD TO BE 0.07mm .
- 7. THESE DIMENSIONS APPLY TO THE FLAT SECTION OF THE LEAD BETWEEN 0.10mm AND 0.25mm FROM THE LEAD TIP.
- 8. LEAD COPLANARITY SHALL BE WITHIN 0.10mm AS MEASURED FROM THE SEATING PLANE.
- 9. DIMENSION "e" IS MEASURED AT THE CENTERLINE OF THE LEADS.
- 10. JEDEC SPECIFICATION NO. REF: MO-142(D)DD.

**Note**

91. For reference only. BSC is an ANSI standard for Basic Space Centering.

Figure 25. VBK048 – 48-Ball Fine-Pitch Ball Grid Array (FBGA) 8.15 mm x 6.15 mm (002-19063)

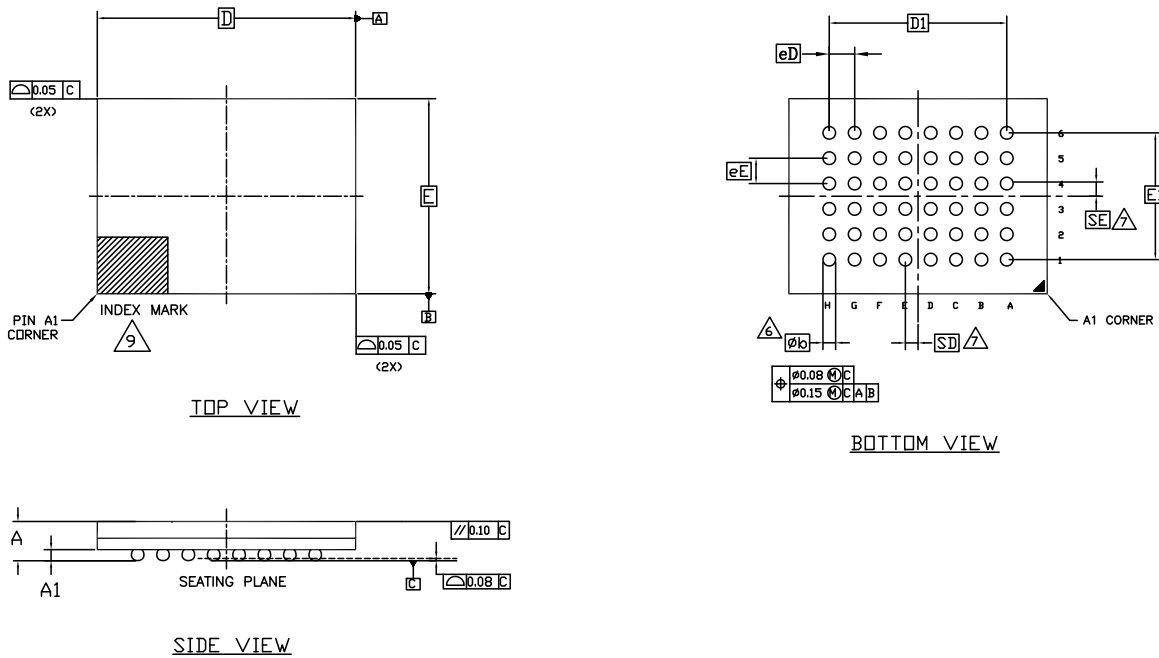

SYMBOL	DIMENSIONS		
	MIN.	NOM.	MAX.
A	—	—	1.00
A1	0.18	—	—
D	8.15 BSC.		
E	6.15 BSC.		
D1	5.60 BSC.		
E1	4.00 BSC.		
MD	8		
ME	6		
n	48		
øb	0.33	—	0.43
eD/eE	0.80 BSC.		
SD/SE	0.40 BSC.		

NOTES:

- DIMENSIONING AND TOLERANCING PER ASME Y14.5M-1994 .
- ALL DIMENSIONS ARE IN MILLIMETERS .
- BALL POSITION DESIGNATION PER JEP95, SECTION 3, SPP-010/020.
- [e] REPRESENTS THE SOLDER BALL GRID PITCH .
- SYMBOL "MD" IS THE BALL ROW MATRIX SIZE IN THE "D" DIRECTION. SYMBOL "ME" IS THE BALL COLUMN MATRIX SIZE IN THE "E" DIRECTION. n IS THE TOTAL NUMBER OF POPULATED SOLDER BALLS FOR MATRIX SIZE MD AND ME.
- DIMENSION "b" IS MEASURED AT THE MAXIMUM BALL DIAMETER IN A PLANE PARALLEL TO DATUM C.
- "SD" AND "SE" ARE MEASURED WITH RESPECT TO DATUMS A AND B AND DEFINE THE POSITION OF THE CENTER SOLDER BALL IN THE OUTER ROW. WHEN THERE IS AN ODD NUMBER OF SOLDER BALLS IN THE OUTER ROW, "SD" OR "SE" = 0. WHEN THERE IS AN EVEN NUMBER OF SOLDER BALLS IN THE OUTER ROW, "SD" = eD/2 and "SE" = eE/2.
- "+" INDICATES THE THEORETICAL CENTER OF DEPOPULATED BALLS.
- A1 CORNER TO BE IDENTIFIED BY CHAMFER, LASER OR INK MARK, METALLIZED MARK INDENTATION OR OTHER MEANS.

Figure 26. VDF048 – 48-Ball Fine-Pitch Ball Grid Array (FBGA) 6.00 mm x 4.00 mm (002-25354)

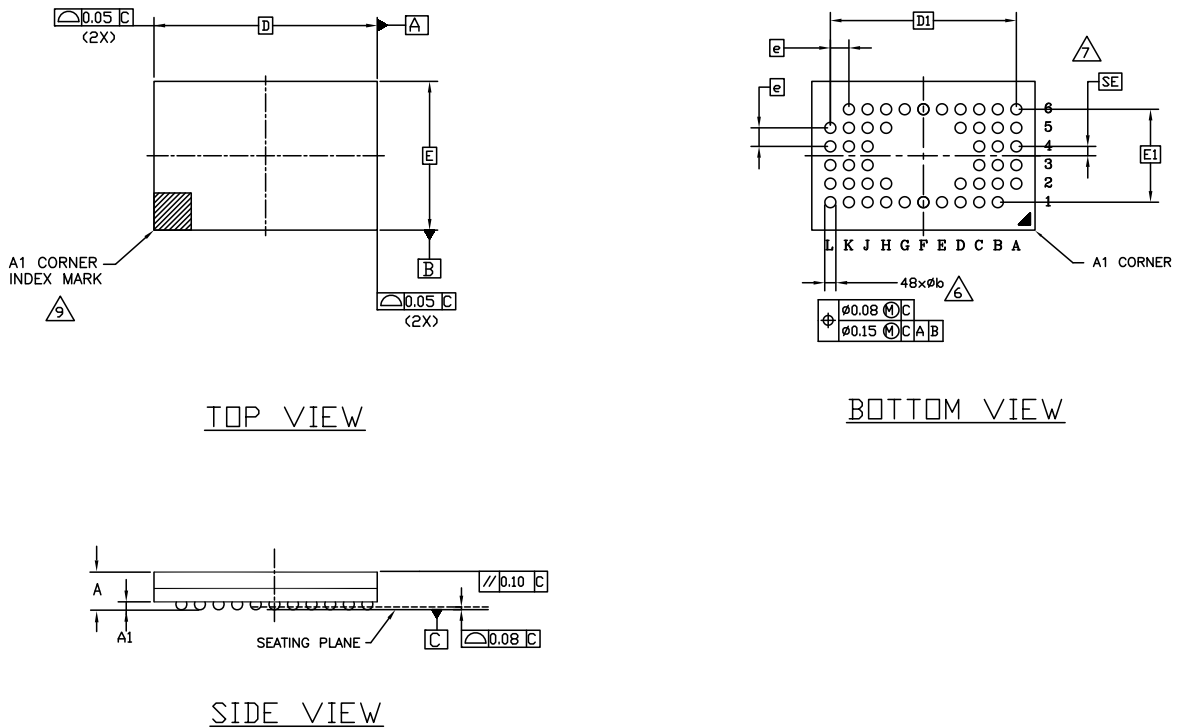

SYMBOL	DIMENSIONS		
	MIN.	NOM.	MAX.
A	-	-	1.00
A1	0.16	-	-
D	6.00 BSC.		
E	4.00 BSC.		
D1	5.00 BSC.		
E1	2.50 BSC.		
MD	11		
ME	6		
N	48		
$\phi b$	0.26	0.31	0.36
e	0.50 BSC.		
SD/SE	0.00/0.25 BSC.		

NOTES:

- DIMENSIONING AND TOLERANCING METHODS PER ASME Y14.5M-1994.
- ALL DIMENSIONS ARE IN MILLIMETERS.
- BALL POSITION DESIGNATION PER JEP95, SECTION 3, SPP-020.
- [e] REPRESENTS THE SOLDER BALL GRID PITCH.
- SYMBOL "MD" IS THE BALL MATRIX SIZE IN THE "D" DIRECTION. SYMBOL "ME" IS THE BALL MATRIX SIZE IN THE "E" DIRECTION. N IS THE NUMBER OF POPULATED SOLDER BALL POSITIONS FOR MATRIX SIZE MD X ME.
- DIMENSION "b" IS MEASURED AT THE MAXIMUM BALL DIAMETER IN A PLANE PARALLEL TO DATUM C.
- "SD" AND "SE" ARE MEASURED WITH RESPECT TO DATUMS A AND B AND DEFINE THE POSITION OF THE CENTER SOLDER BALL IN THE OUTER ROW. WHEN THERE IS AN ODD NUMBER OF SOLDER BALLS IN THE OUTER ROW, "SD" OR "SE"=0. WHEN THERE IS AN EVEN NUMBER OF SOLDER BALLS IN THE OUTER ROW, "SD"= $eD/2$  AND "SE"= $eE/2$ .
- "+" INDICATES THE THEORETICAL CENTER OF DEPOPULATED BALLS.
- A1 CORNER TO BE IDENTIFIED BY CHAMFER, LASER OR INK MARK, METALLIZED MARK INDENTATION OR OTHER MEANS.

## 22. Document History

Document Title: S29AS016J, 16 Mbit (2 M x 8-Bit/1 M x 16-Bit), 1.8 V Boot Sector Flash Document Number: 002-01122				
Rev.	ECN No.	Orig. of Change	Submission Date	Description of Change
**	-	RYSU	03/02/2007	Spansion Publication Number: S29AS016J_00 Global Initial release
*A	-	RYSU	07/13/2007	Global Removed ACC description Changed VID voltage range from 8.5 - 12.5 V to 9.0 - 11.0 V <b>Sector Protection/Unprotection</b> Corrected and error in the sector group table
*B	-	RYSU	10/29/2007	<b>Ordering information</b> Deleted all Leaded package offerings Table S29AS016J Autoselect Codes (High Voltage Method) Updated table Table Primary Vendor-Specific Extended Query Corrected the data of CFI address 44 Hex <b>Unlock Bypass Command Sequence</b> Corrected the 2nd cycle data of the Unlock Bypass Command from '00' hex to 'F0' hex Absolute Maximum Ratings Under Note 2: Changed the maximum DC input voltage on pin A9 from 12.5V to 11.0V and its overshoot from 14.0V to 12.5V <b>Table CMOS Compatible</b> Changed the parameter ILIT to ILI
*C	-	RYSU	06/04/2008	Ordering Information Removed all 50 ns speed option and FBGA package offerings Updated Valid Combination table <b>CMOS Compatible</b> Updated Note 4 TSOP and BGA Pin Capacitance Changed Title to Package Pin Capacitance Added WLCSP Information Distinctive Characteristics Added WLCSP Package Option Connection Diagram Removed VBK048 Added WLCSP <b>Physical Dimension</b> Removed VBK048 Added WLCSP Common Flash Memory Interface Updated table <i>Primary Vendor-Specific Extended Query</i>
*D	-	RYSU	08/19/2008	<b>Sector Protection/Unprotection</b> Replaced entire section Global Modified all references to sector protection, sector unprotection, temporary sector unprotect, and temporary sector unprotect to sector group protection, sector group unprotection, temporary sector group unprotect, and temporary sector group unprotect <b>WLCSP Connection Diagram</b> Changed Pin from A18+ to A19 In-System Sector Group Protect/Unprotect Algorithms Added Note <b>Read Operations</b> Added note 3
*E	-	RYSU	10/27/2008	Customer Lockable: Secured Silicon Sector Programmed and Protected at the Factory Modified first bullet Updated figure Secured Silicon Sector Protect Verify <b>TSOP and Pin Capacitance</b> Updated Table

Document Title: S29AS016J, 16 Mbit (2 M x 8-Bit/1 M x 16-Bit), 1.8 V Boot Sector Flash Document Number: 002-01122				
Rev.	ECN No.	Orig. of Change	Submission Date	Description of Change
*F	-	RYSU	03/06/2009	<b>Ordering Information</b> Updated the Valid Communication table <b>Connection Diagrams</b> Added VBK048 <b>Special Handling Instructions</b> Added section <b>Package Pin Capacitance</b> Updated table <b>Physical Dimensions</b> Added VBK048 Table: Erase and Programming Performance Updated table
*G	-	RYSU	07/14/2009	<b>Global</b> Removed all references to WLCSP from data sheet
*H	-	RYSU	08/12/2010	<b>Ordering Information</b> Added 03 and 04 model numbers. Added note regarding the deprecated use of model numbers 01 and 02 Read Operations Modified note 3 to apply only to devices with model numbers 01 and 02.
*I	-	RYSU	11/18/2010	Global Added 6.0 mm x 4.0 mm package option - VDF 048 RESET#: Hardware Reset Pin Added sentence regarding use of CE# with RESET# RESET# Timings Figure Added note.
*J	-	RYSU	02/01/2012	<b>Global</b> Added product support for Automotive In-Cabin temperature range Ordering Information Added 90 ns speed grade support for Automotive In-Cabin products only Added Low-halogen BGA (VBK048) ordering option <b>DC Characteristics</b> Added column for Automotive In-cabin temperature specific changes
*K	5038960	RYSU	15/09/2015	Updated to cypress Template.
*L	5746135	NIBK	05/23/2017	Updated Cypress Logo and Copyright.
*M	6524617	PRIT	04/16/2019	Updated template. Added Automotive Grade A and B in <a href="#">Distinctive Characteristics on page 1, Section 6.</a> <a href="#">Ordering Information on page 9, Section 14.</a> <a href="#">Operating Ranges on page 39, Section 15.1</a> <a href="#">CMOS Compatible on page 40, and Section 21.</a> <a href="#">Physical Dimensions on page 52.</a>

## Sales, Solutions, and Legal Information

### Worldwide Sales and Design Support

Cypress maintains a worldwide network of offices, solution centers, manufacturer's representatives, and distributors. To find the office closest to you, visit us at [Cypress Locations](#).

### Products

Arm® Cortex® Microcontrollers	<a href="http://cypress.com/arm">cypress.com/arm</a>
Automotive	<a href="http://cypress.com/automotive">cypress.com/automotive</a>
Clocks & Buffers	<a href="http://cypress.com/clocks">cypress.com/clocks</a>
Interface	<a href="http://cypress.com/interface">cypress.com/interface</a>
Internet of Things	<a href="http://cypress.com/iot">cypress.com/iot</a>
Memory	<a href="http://cypress.com/memory">cypress.com/memory</a>
Microcontrollers	<a href="http://cypress.com/mcu">cypress.com/mcu</a>
PSoC	<a href="http://cypress.com/psoc">cypress.com/psoc</a>
Power Management ICs	<a href="http://cypress.com/pmic">cypress.com/pmic</a>
Touch Sensing	<a href="http://cypress.com/touch">cypress.com/touch</a>
USB Controllers	<a href="http://cypress.com/usb">cypress.com/usb</a>
Wireless Connectivity	<a href="http://cypress.com/wireless">cypress.com/wireless</a>

### PSoC® Solutions

[PSoC 1](#) | [PSoC 3](#) | [PSoC 4](#) | [PSoC 5LP](#) | [PSoC 6 MCU](#)

### Cypress Developer Community

[Community](#) | [Projects](#) | [Video](#) | [Blogs](#) | [Training](#) | [Components](#)

### Technical Support

[cypress.com/support](http://cypress.com/support)



© Cypress Semiconductor Corporation 2007- 2019. This document is the property of Cypress Semiconductor Corporation and its subsidiaries ("Cypress"). This document, including any software or firmware included or referenced in this document ("Software"), is owned by Cypress under the intellectual property laws and treaties of the United States and other countries worldwide. Cypress reserves all rights under such laws and treaties and does not, except as specifically stated in this paragraph, grant any license under its patents, copyrights, trademarks, or other intellectual property rights. If the Software is not accompanied by a license agreement and you do not otherwise have a written agreement with Cypress governing the use of the Software, then Cypress hereby grants you a personal, non-exclusive, nontransferable license (without the right to sublicense) (1) under its copyright rights in the Software (a) for Software provided in source code form, to modify and reproduce the Software solely for use with Cypress hardware products, only internally within your organization, and (b) to distribute the Software in binary code form externally to end users (either directly or indirectly through resellers and distributors), solely for use on Cypress hardware product units, and (2) under those claims of Cypress's patents that are infringed by the Software (as provided by Cypress, unmodified) to make, use, distribute, and import the Software solely for use with Cypress hardware products. Any other use, reproduction, modification, translation, or compilation of the Software is prohibited.

TO THE EXTENT PERMITTED BY APPLICABLE LAW, CYPRESS MAKES NO WARRANTY OF ANY KIND, EXPRESS OR IMPLIED, WITH REGARD TO THIS DOCUMENT OR ANY SOFTWARE OR ACCOMPANYING HARDWARE, INCLUDING, BUT NOT LIMITED TO, THE IMPLIED WARRANTIES OF MERCHANTABILITY AND FITNESS FOR A PARTICULAR PURPOSE. No computing device can be absolutely secure. Therefore, despite security measures implemented in Cypress hardware or software products, Cypress shall have no liability arising out of any security breach, such as unauthorized access to or use of a Cypress product. CYPRESS DOES NOT REPRESENT, WARRANT, OR GUARANTEE THAT CYPRESS PRODUCTS, OR SYSTEMS CREATED USING CYPRESS PRODUCTS, WILL BE FREE FROM CORRUPTION, ATTACK, VIRUSES, INTERFERENCE, HACKING, DATA LOSS OR THEFT, OR OTHER SECURITY INTRUSION (collectively, "Security Breach"). Cypress disclaims any liability relating to any Security Breach, and you shall and hereby do release Cypress from any claim, damage, or other liability arising from any Security Breach. In addition, the products described in these materials may contain design defects or errors known as errata which may cause the product to deviate from published specifications. To the extent permitted by applicable law, Cypress reserves the right to make changes to this document without further notice. Cypress does not assume any liability arising out of the application or use of any product or circuit described in this document. Any information provided in this document, including any sample design information or programming code, is provided only for reference purposes. It is the responsibility of the user of this document to properly design, program, and test the functionality and safety of any application made of this information and any resulting product. "High-Risk Device" means any device or system whose failure could cause personal injury, death, or property damage. Examples of High-Risk Devices are weapons, nuclear installations, surgical implants, and other medical devices. "Critical Component" means any component of a High-Risk Device whose failure to perform can be reasonably expected to cause, directly or indirectly, the failure of the High-Risk Device, or to affect its safety or effectiveness. Cypress is not liable, in whole or in part, and you shall and hereby do release Cypress from any claim, damage, or other liability arising from any use of a Cypress product as a Critical Component in a High-Risk Device. You shall indemnify and hold Cypress, its directors, officers, employees, agents, affiliates, distributors, and assigns harmless from and against all claims, costs, damages, and expenses, arising out of any claim, including claims for product liability, personal injury or death, or property damage arising from any use of a Cypress product as a Critical Component in a High-Risk Device. Cypress products are not intended or authorized for use as a Critical Component in any High-Risk Device except to the limited extent that (i) Cypress's published data sheet for the product explicitly states Cypress has qualified the product for use in a specific High-Risk Device, or (ii) Cypress has given you advance written authorization to use the product as a Critical Component in the specific High-Risk Device and you have signed a separate indemnification agreement.

Cypress, the Cypress logo, Spansion, the Spansion logo, and combinations thereof, WICED, PSoC, CapSense, EZ-USB, F-RAM, and Traveo are trademarks or registered trademarks of Cypress in the United States and other countries. For a more complete list of Cypress trademarks, visit [cypress.com](http://cypress.com). Other names and brands may be claimed as property of their respective owners.

## Looking for pricing, stock, or lifecycle information?

Click below to explore more details on WIN SOURCE:

-  [View S29AS016J70BHIF40 on WIN SOURCE](#)
-  [Cypress Semiconductor Corp Information](#)

## Optimize Your Supply Chain with WIN SOURCE Solutions

-  Global Sourcing Solution
-  Obsolete Management
-  Cost Control Management
-  Shortage Management
-  Alternative Solution
-  Excess Inventory Management