



**THE DATASHEET OF
6PAIC23BIPWRG4Q1**



TLV320AIC23B-Q1

Stereo Audio Codec, 8- to 96-kHz, With Integrated Headphone Amplifier

Data Manual



PRODUCTION DATA information is current as of publication date. Products conform to specifications per the terms of the Texas Instruments standard warranty. Production processing does not necessarily include testing of all parameters.

Literature Number: SGLS240C
March 2004–Revised June 2012

Stereo Audio Codec, 8- to 96-kHz, With Integrated Headphone Amplifier

Check for Samples: [TLV320AIC23B-Q1](#)

1 Introduction

1.1 Features

- **Qualified for Automotive Applications**
- **High-Performance Stereo Codec**
 - 90-dB SNR Multibit Sigma-Delta ADC (A-weighted at 48 kHz)
 - 100-dB SNR Multibit Sigma-Delta DAC (A-weighted at 48 kHz)
 - 1.42 V – 3.6 V Core Digital Supply: Compatible With TI C54x DSP Core Voltages
 - 2.7 V – 3.6 V Buffer and Analog Supply: Compatible Both TI C54x DSP Buffer Voltages
 - 8-kHz – 96-kHz Sampling-Frequency Support
- **Software Control Via TI McBSP-Compatible Multiprotocol Serial Port**
 - 2-wire-Compatible and SPI-Compatible Serial-Port Protocols
 - Glueless Interface to TI McBSPs
- **Audio-Data Input/Output Via TI McBSP-Compatible Programmable Audio Interface**
 - I²S-Compatible Interface Requiring Only One McBSP for both ADC and DAC
 - Standard I²S, MSB, or LSB Justified-Data Transfers
 - 16/20/24/32-Bit Word Lengths
 - Audio Master/Slave Timing Capability Optimized for TI DSPs (250/272 f_s), USB mode
 - Industry-Standard Master/Slave Support Provided Also (256/384 f_s), Normal mode
 - Glueless Interface to TI McBSPs
- **Integrated Total Electret-Microphone Biasing and Buffering Solution**
 - Low-Noise MICBIAS pin at 3/4 AVDD for Biasing of Electret Capsules
 - Integrated Buffer Amplifier With Tunable Fixed Gain of 1 to 5
 - Additional Control-Register Selectable Buffer Gain of 0 dB or 20 dB
- **Stereo-Line Inputs**
 - Integrated Programmable Gain Amplifier
 - Analog Bypass Path of Codec
- **ADC Multiplexed Input for Stereo-Line Inputs and Microphone**
- **Stereo-Line Outputs**
 - Analog Stereo Mixer for DAC and Analog Bypass Path
- **Volume Control With Mute on Input and Output**
- **Highly Efficient Linear Headphone Amplifier**
 - 30 mW into 32 Ω From a 3.3-V Analog Supply Voltage
- **Flexible Power Management Under Total Software Control**
 - 23-mW Power Consumption During Playback Mode
 - Standby Power Consumption < 150 μW
 - Power-Down Power Consumption < 15 μW
- **28-Pin TSSOP (62 mm² Total Board Area)**
- **Ideally Suitable for Portable Solid-State Audio Players and Recorders**

1.2 Description

The TLV320AIC23B-Q1 is a high-performance stereo audio codec with highly integrated analog functionality. The analog-to-digital converters (ADCs) and digital-to-analog converters (DACs) within the TLV320AIC23B-Q1 use multibit sigma-delta technology with integrated oversampling digital interpolation filters. Data-transfer word lengths of 16, 20, 24, and 32 bits, with sample rates from 8 kHz to 96 kHz, are supported. The ADC sigma-delta modulator features third-order multibit architecture with up to 90-dBA signal-to-noise ratio (SNR) at audio sampling rates up to 96 kHz, enabling high-fidelity audio recording in a compact, power-saving design. The DAC sigma-delta modulator features a second-order multibit architecture with up to 100-dBA SNR at audio sampling rates up to 96 kHz, enabling high-quality digital audio-playback capability, while consuming less than 23 mW during playback only. The TLV320AIC23B-Q1 is the ideal analog input/output (I/O) choice for portable digital audio-player and recorder applications, such as MP3 digital audio players.



Please be aware that an important notice concerning availability, standard warranty, and use in critical applications of Texas Instruments semiconductor products and disclaimers thereto appears at the end of this data sheet.

Integrated analog features consist of stereo-line inputs with an analog bypass path, a stereo headphone amplifier, with analog volume control and mute, and a complete electret-microphone-capsule biasing and buffering solution. The headphone amplifier is capable of delivering 30 mW per channel into 32 Ω . The analog bypass path allows use of the stereo-line inputs and the headphone amplifier with analog volume control, while completely bypassing the codec, thus enabling further design flexibility, such as integrated FM tuners. A microphone bias-voltage output provides a low-noise current source for electret-capsule biasing. The AIC23B has an integrated adjustable microphone amplifier (gain adjustable from 1 to 5) and a programmable gain microphone amplifier (0 dB or 20 dB). The microphone signal can be mixed with the output signals if a sidetone is required.

While the TLV320AIC23B-Q1 supports the industry-standard oversampling rates of 256 f_s and 384 f_s , unique oversampling rates of 250 f_s and 272 f_s are provided, which optimize interface considerations in designs using TI C54x digital signal processors (DSPs) and universal serial bus (USB) data interfaces. A single 12-MHz crystal can supply clocking to the DSP, USB, and codec. The TLV320AIC23B-Q1 features an internal oscillator that, when connected to a 12-MHz external crystal, provides a system clock to the DSP and other peripherals at either 12 MHz or 6 MHz, using an internal clock buffer and selectable divider. Audio sample rates of 48 kHz and compact-disc (CD) standard 44.1 kHz are supported directly from a 12-MHz master clock with 250 f_s and 272 f_s oversampling rates.

Low power consumption and flexible power management allow selective shutdown of codec functions, thus extending battery life in portable applications. This design solution makes powerful portable stereo audio designs easily realizable in a cost-effective, space-saving total analog I/O solution: the TLV320AIC23B-Q1.

1.4 Pin Assignments

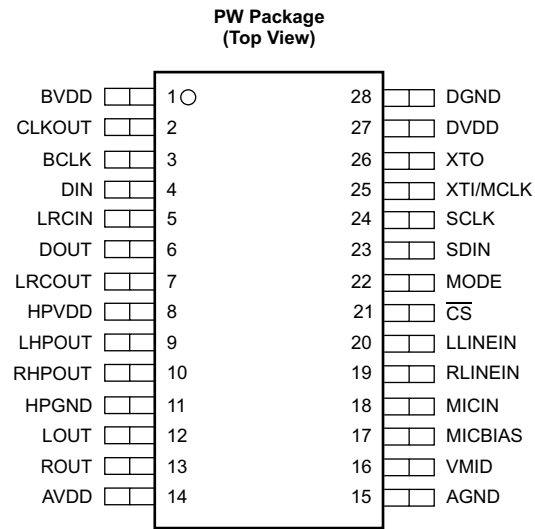

P0043-05

1.5 Ordering Information

T_A	PACKAGE	REEL	ORDERABLE PART NUMBER	TOP-SIDE MARKING
-40°C to 85°C	TSSOP	2000	TLV320AIC23BIPWRQ1	AIC23BIQ1

1.6 Pin Functions

Table 1-1. Pin Functions

PIN		I/O	DESCRIPTION
NAME	NO.		
AGND	15		Analog supply return
AVDD	14		Analog supply input. Voltage level is 3.3 V nominal.
BCLK	3	I/O	I ² S serial-bit clock. In audio master mode, the AIC23B generates this signal and sends it to the DSP. In audio slave mode, the signal is generated by the DSP.
BVDD	1		Buffer supply input. Voltage range is from 2.7 V to 3.6 V.
CLKOUT	2	O	Clock output. This is a buffered version of the XTI input and is available in 1X or 1/2X frequencies of XTI. Bit 07 in the sample rate control register controls frequency selection.
$\overline{\text{CS}}$	21	I	Control port input latch/address select. For SPI control mode this input acts as the data latch control. For 2-wire control mode this input defines the seventh bit in the device address field. See Section 3.1 for details.
DIN	4	I	I ² S format serial data input to the sigma-delta stereo DAC
DGND	28		Digital supply return
DOUT	6	O	I ² S format serial data output from the sigma-delta stereo ADC
DVDD	27		Digital supply input. Voltage range is 1.4 V to 3.6 V.
HPGND	11		Analog headphone amplifier supply return
HPVDD	8		Analog headphone amplifier supply input. Voltage level is 3.3 V nominal.
LHPOUT	9	O	Left stereo mixer-channel amplified headphone output. Nominal 0-dB output level is 1 VRMS. Gain of –73 dB to 6 dB is provided in 1-dB steps.
LLINEIN	20	I	Left stereo-line input channel. Nominal 0-dB input level is 1 VRMS. Gain of –34.5 dB to 12 dB is provided in 1.5-dB steps.
LOUT	12	O	Left stereo mixer-channel line output. Nominal output level is 1.0 VRMS.
LRCIN	5	I/O	I ² S DAC-word clock signal. In audio master mode, the AIC23B generates this framing signal and sends it to the DSP. In audio slave mode, the signal is generated by the DSP.
LRCOUT	7	I/O	I ² S ADC-word clock signal. In audio master mode, the AIC23B generates this framing signal and sends it to the DSP. In audio slave mode, the signal is generated by the DSP.
MICBIAS	17	O	Buffered low-noise-voltage output suitable for electret-microphone-capsule biasing. Voltage level is 3/4 AVDD nominal.
MICIN	18	I	Buffered amplifier input suitable for use with electret-microphone capsules. Without external resistors a default gain of 5 is provided. See Section 2.3.1.2 for details.
MODE	22	I	Serial-interface-mode input. See Section 3.1 for details.
NC			Not Used—No internal connection
RHPOUT	10	O	Right stereo mixer-channel amplified headphone output. Nominal 0-dB output level is 1 VRMS. Gain of –73 dB to 6 dB is provided in 1-dB steps.
RLINEIN	19	I	Right stereo-line input channel. Nominal 0-dB input level is 1 VRMS. Gain of –34.5 dB to 12 dB is provided in 1.5-dB steps.
ROUT	13	O	Right stereo mixer-channel line output. Nominal output level is 1.0 VRMS.
SCLK	24	I	Control-port serial-data clock. For SPI and 2-wire control modes this is the serial-clock input. See Section 3.1 for details.
SDIN	23	I	Control-port serial-data input. For SPI and 2-wire control modes this is the serial-data input and also is used to select the control protocol after reset. See Section 3.1 for details.
VMID	16	I	Midrail voltage decoupling input. 10- μ F and 0.1- μ F capacitors should be connected in parallel to this terminal for noise filtering. Voltage level is 1/2 AVDD nominal.
XTI/MCLK	25	I	Crystal or external-clock input. Used for derivation of all internal clocks on the AIC23B.
XTO	26	O	Crystal output. Connect to external crystal for applications where the AIC23B is the audio timing master. Not used in applications where external clock source is used.

2 Electrical Specifications

2.1 Absolute Maximum Ratings⁽¹⁾

over operating free-air temperature range (unless otherwise noted)

		VALUE	UNIT
Supply voltage range ⁽²⁾	AV _{DD} to AGND, DV _{DD} to DGND, BV _{DD} to DGND, HPV _{DD} to HPGND	–0.3 to 3.63	V
Analog supply return to digital supply return	AGND to DGND	–0.3 to 3.63	V
Input voltage range, all input signals	Digital	–0.3 to DV _{DD}	V
	Analog	–0.3 to AV _{DD}	V
Case temperature for 10 seconds		240	°C
Operating free-air temperature range: Industrial, T _A		–40 to 85	°C
Storage temperature range, T _{stg}		–65 to 150	°C

- (1) Stresses beyond those listed under *Absolute Maximum Ratings* may cause permanent damage to the device. These are stress ratings only, and functional operation of the device at these or any other conditions beyond those indicated under *Recommended Operating Conditions* is not implied. Exposure to absolute-maximum-rated conditions for extended periods may affect device reliability.
- (2) DV_{DD} may not exceed BV_{DD} 0.3 V; BV_{DD} may not exceed AV_{DD} 0.3 V or HPV_{DD} 0.3.

2.2 Recommended Operating Conditions

over operating free-air temperature range (unless otherwise noted)

	MIN	NOM	MAX	UNIT
Analog supply voltage, AV _{DD} , HPV _{DD} ⁽¹⁾	2.7	3.3	3.6	V
Digital buffer supply voltage, BV _{DD} ⁽¹⁾	2.7	3.3	3.6	V
Digital core supply voltage, DV _{DD} ⁽¹⁾	1.42	1.5	3.6	V
Analog input voltage, full scale – 0 dB (AV _{DD} = 3.3 V)		1		V _{RMS}
Stereo-line output load resistance	10			kΩ
Headphone-amplifier output load resistance	0			Ω
CLKOUT digital output load capacitance		20		pF
All other digital output load capacitance		10		pF
Stereo-line output load capacitance		50		pF
XTI master clock Input			18.43	MHz
ADC or DAC conversion rate			96	kHz
Operating free-air temperature, T _A	Industrial	–40	85	°C

- (1) Digital voltage values are with respect to DGND; analog voltage values are with respect to AGND.

2.3 Electrical Characteristics

over recommended operating conditions, AV_{DD}, HPV_{DD}, BV_{DD} = 3.3 V, DV_{DD} = 1.5 V, slave mode, XTI/MCLK = 256 f_s, f_s = 48 kHz (unless otherwise stated)

2.3.1 ADC

2.3.1.1 Line Input to ADC

PARAMETER	TEST CONDITIONS	MIN	TYP	MAX	UNIT
Input signal level (0 dB)			1		V _{RMS}
Signal-to-noise ratio, A-weighted, 0-dB gain ⁽¹⁾⁽²⁾	f _s = 48 kHz (3.3 V)	85	90		dB
	f _s = 48 kHz (2.7 V)		90		
Dynamic range, A-weighted, –60-dB full-scale input ⁽²⁾	AV _{DD} = 3.3 V	85	90		dB
	AV _{DD} = 2.7 V		90		
Total harmonic distortion, –1-dB input, 0-dB gain	AV _{DD} = 3.3 V		–80		dB
	AV _{DD} = 2.7 V		80		
Power supply rejection ratio	1 kHz, 100 mV _{pp}		50		dB
ADC channel separation	1 kHz input tone		90		dB
Programmable gain	1 kHz input tone, R _{SOURCE} < 50 Ω	–34.5		12	dB
Programmable gain step size	Monotonic		1.5		dB
Mute attenuation	0 dB, 1 kHz input tone		80		dB
Input resistance	12 dB input gain	10		20	kΩ
	0 dB input gain	28	35		
Input capacitance			10		pF

- (1) Ratio of output level with 1-kHz full-scale input, to the output level with the input short circuited, measured A-weighted over a 20-Hz to 20-kHz bandwidth using an audio analyzer.
- (2) All performance measurements done with 20-kHz low-pass filter and, where noted, A-weighted filter. Failure to use such a filter results in higher THD + N and lower SNR and dynamic range readings than shown in the Electrical Characteristics. The low-pass filter removes out-of-band noise, which, although not audible, may affect dynamic specification values.

2.3.1.2 Microphone Input to ADC

0-dB Gain, f_s = 8 kHz (40-KΩ source impedance, see Section 1.3)

PARAMETER	TEST CONDITIONS	MIN	TYP	MAX	UNIT
Input signal level (0 dB)			1		V _{RMS}
Signal-to-noise ratio, A-weighted, 0-dB gain ⁽¹⁾⁽²⁾	AV _{DD} = 3.3 V	77	85		dB
	AV _{DD} = 2.7 V		84		
Dynamic range, A-weighted, –60-dB full-scale input ⁽²⁾	AV _{DD} = 3.3 V	77	85		dB
	AV _{DD} = 2.7 V		84		
Total harmonic distortion, –1-dB input, 0-dB gain	AV _{DD} = 3.3 V		–60		dB
	AV _{DD} = 2.7 V		–60		
Power supply rejection ratio	1 kHz, 100 mV _{pp}		50		dB
Programmable gain boost	1 kHz input tone, R _{SOURCE} < 50 Ω		20		dB
Microphone-path gain	MICBOOST = 0, R _{SOURCE} < 50 Ω		14		dB
Mute attenuation	0 dB, 1 kHz input tone	60	80		dB
Input resistance		8	14		kΩ
Input capacitance			10		pF

- (1) Ratio of output level with 1-kHz full-scale input, to the output level with the input short circuited, measured A-weighted over a 20-Hz to 20-kHz bandwidth using an audio analyzer.
- (2) All performance measurements done with 20-kHz low-pass filter and, where noted, A-weighted filter. Failure to use such a filter results in higher THD + N and lower SNR and dynamic range readings than shown in the Electrical Characteristics. The low-pass filter removes out-of-band noise, which, although not audible, may affect dynamic specification values.

2.3.1.3 Microphone Bias

PARAMETER	TEST CONDITIONS	MIN	TYP	MAX	UNIT
Bias voltage		$3/4 AV_{DD} - 100 \text{ m}$	$3/4 AV_{DD}$	$3/4 AV_{DD} + 100 \text{ m}$	V
Bias-current source				3	mA
Output noise voltage	1 kHz to 20 kHz		25		nV/ $\sqrt{\text{Hz}}$

2.3.2 DAC

Line output, load = 10 k Ω , 50 pF

PARAMETER	TEST CONDITIONS		MIN	TYP	MAX	UNIT
0-dB full-scale output voltage (FFFFFF)				1		V_{RMS}
Signal-to-noise ratio, A-weighted, 0-dB gain ⁽¹⁾⁽²⁾⁽³⁾	$AV_{DD} = 3.3 \text{ V}$	$f_s = 48 \text{ kHz}$	90	100		dB
	$AV_{DD} = 2.7 \text{ V}$	$f_s = 48 \text{ kHz}$		100		
Dynamic range, A-weighted ⁽²⁾	$AV_{DD} = 3.3 \text{ V}$		85	90		dB
	$AV_{DD} = 2.7 \text{ V}$			TBD		
Total harmonic distortion	$AV_{DD} = 3.3 \text{ V}$	1 kHz, 0 dB		-88	-80	dB
		1 kHz, -3 dB		-92	-86	
	$AV_{DD} = 2.7 \text{ V}$	1 kHz, 0 dB		-85		dB
		1 kHz, -3 dB		-88		
Power supply rejection ratio	1 kHz, 100 mV _{pp}			50		dB
DAC channel separation				100		dB

- (1) Ratio of output level with 1-kHz full-scale input, to the output level with the input short circuited, measured A-weighted over a 20-Hz to 20-kHz bandwidth using an audio analyzer
- (2) All performance measurements done with 20-kHz low-pass filter and, where noted, A-weighted filter. Failure to use such a filter results in higher THD + N and lower SNR and dynamic range readings than shown in the Electrical Characteristics. The low-pass filter removes out-of-band noise, which, although not audible, may affect dynamic specification values.
- (3) Ratio of output level with 1-kHz full-scale input, to the output level with all zeros into the digital input, measured A-weighted over a 20-Hz to 20-kHz bandwidth.

2.3.3 Analog Line Input to Line Output (Bypass)

PARAMETER	TEST CONDITIONS		MIN	TYP	MAX	UNIT
0-dB full-scale output voltage				1		V_{RMS}
Signal-to-noise ratio, A-weighted, 0-dB gain ⁽¹⁾⁽²⁾	$AV_{DD} = 3.3 \text{ V}$		90	95		dB
	$AV_{DD} = 2.7 \text{ V}$			95		
Total harmonic distortion	$AV_{DD} = 3.3 \text{ V}$	1 kHz, 0 dB		-86	-80	dB
		1 kHz, -3 dB		-92	-86	
	$AV_{DD} = 2.7 \text{ V}$	1 kHz, 0 dB		-86		dB
		1 kHz, -3 dB		-92		
Power supply rejection ratio	1 kHz, 100 mV _{pp}			50		dB
DAC channel separation (left to right)	1 kHz, 0 dB			80		dB

- (1) Ratio of output level with 1-kHz full-scale input, to the output level with the input short circuited, measured A-weighted over a 20-Hz to 20-kHz bandwidth using an audio analyzer.
- (2) All performance measurements done with 20-kHz low-pass filter and, where noted, A-weighted filter. Failure to use such a filter results in higher THD + N and lower SNR and dynamic range readings than shown in the Electrical Characteristics. The low-pass filter removes out-of-band noise, which, although not audible, may affect dynamic specification values.

2.3.4 Stereo Headphone Output

PARAMETER	TEST CONDITIONS		MIN	TYP	MAX	UNIT
0-dB full-scale output voltage				1		VRMS
Maximum output power, P _O	RL = 32 Ω			30		mW
	RL = 16 Ω			40		
Signal-to-noise ratio, A-weighted ⁽¹⁾	AV _{DD} = 3.3 V		88	97		dB
Total harmonic distortion	AV _{DD} = 3.3 V, 1 kHz output	PO = 10 mW			0.1	%
		PO = 20 mW			1	
Power supply rejection ratio	1 kHz, 100 mV _{pp}			50		dB
Programmable gain	1 kHz output		-73		6	dB
Programmable-gain step size				1		dB
Mute attenuation	1 kHz output			80		dB

(1) All performance measurements done with 20-kHz low-pass filter and, where noted, A-weighted filter. Failure to use such a filter results in higher THD + N and lower SNR and dynamic range readings than shown in the Electrical Characteristics. The low-pass filter removes out-of-band noise, which, although not audible, may affect dynamic specification values.

2.3.5 Analog Reference Levels

PARAMETER	MIN	TYP	MAX	UNIT
Reference voltage	AV _{DD} /2 - 50 mV		AV _{DD} /2 + 50 mV	V
Divider resistance	40	50	60	kΩ

2.3.6 Digital I/O

PARAMETER	MIN	TYP	MAX	UNIT
V _{IL} Input low level			0.3 × BV _{DD}	V
V _{IH} Input high level	0.7 × BV _{DD}			V
V _{OL} Output low level			0.1 × BV _{DD}	V
V _{OH} Output high level	0.9 × BV _{DD}			V

2.3.7 Supply Current

PARAMETER	TEST CONDITIONS	MIN	TYP	MAX	UNIT
Total supply current, No input signal I _{TOT}	Record and playback (all active)	20	24	26	mA
	Record and playback (osc, clk, and MIC output powered down)	16	18	20	
	Line playback only	6	7.5	9	
	Record only	11	13.5	15	
	Analog bypass (line in to line out)	4	4.5	6	
	Power down, DV _{DD} = 1.5 V, AV _{DD} = BV _{DD} = HPV _{DD} = 3.3 V	Oscillator enabled	0.8	1.5	
Oscillator disabled			0.01		

2.4 Digital-Interface Timing

PARAMETER	MIN	TYP	MAX	UNIT
tw(1) System-clock pulse duration, MCLK/XTI	High	18		ns
	Low	18		
tc(1) System-clock period, MCLK/XTI	54			ns
Duty cycle, MCLK/XTI	40/60		60/40	%
tpd(1) Propagation delay, CLKOUT	0		10	ns

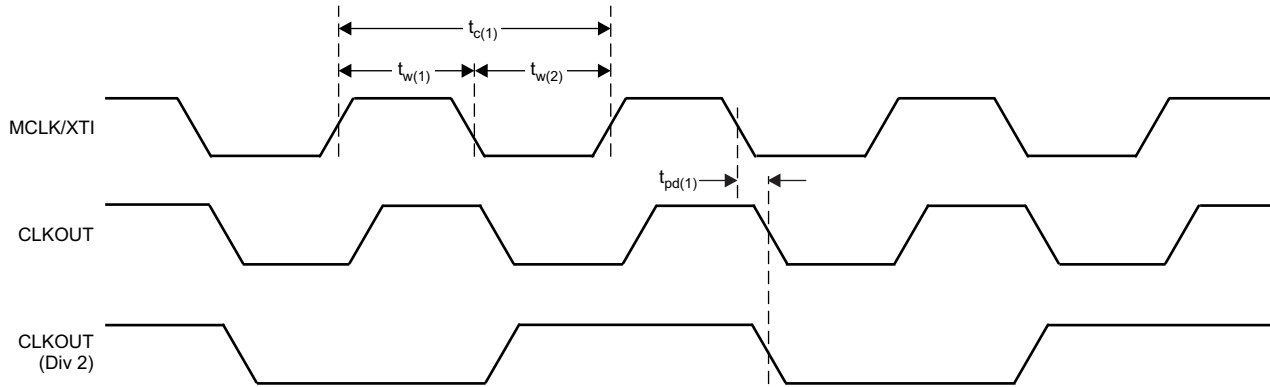

T0547-01

Figure 2-1. System-Clock Timing Requirements

2.4.1 Audio Interface (Master Mode)

PARAMETER		MIN	TYP	MAX	UNIT
tpd(2)	Propagation delay, LRCIN/LRCOUT	0		10	ns
tpd(3)	Propagation delay, DOUT	0		10	ns
tsu(1)	Setup time, DIN	10			ns
th(1)	Hold time, DIN	10			ns

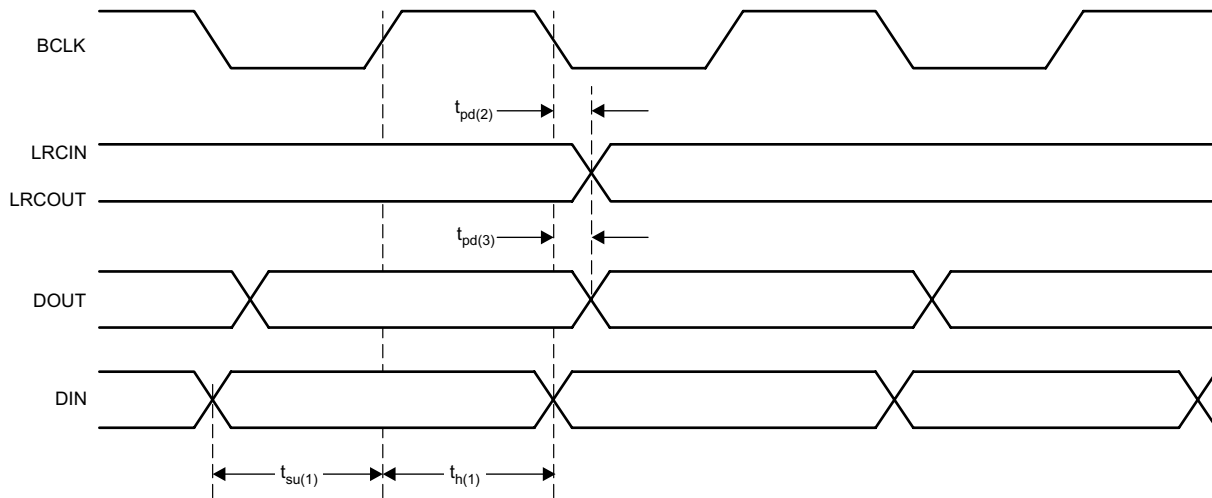

T0548-01

Figure 2-2. Master-Mode Timing Requirements

2.4.2 Audio Interface (Slave-Mode)

PARAMETER		MIN	TYP	MAX	UNIT
tw(3)	Pulse duration, BCLK	High	20		ns
		Low	20		
tc(2)	Clock period, BCLK	50			ns
tpd(4)	Propagation delay, DOUT	0		10	ns
tsu(2)	Setup time, DIN	10			ns
th(2)	Hold time, DIN	10			ns
tsu(3)	Setup time, LRCIN	10			ns
th(3)	Hold time, LRCIN	10			ns

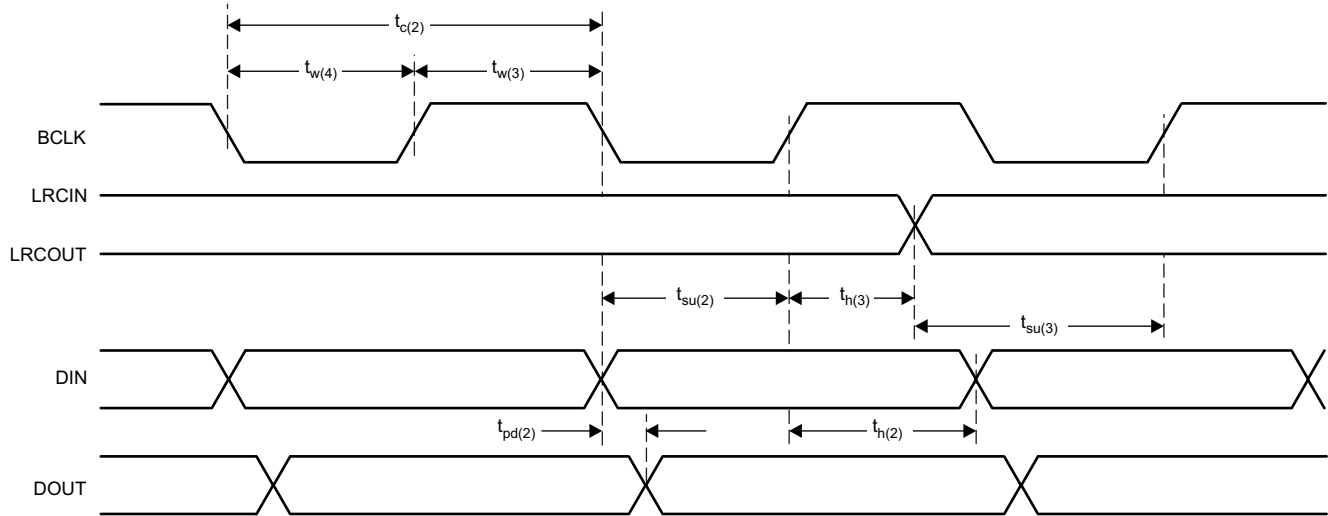

T0549-01

Figure 2-3. Slave-Mode Timing Requirements

2.4.3 3-Wire Control Interface (SDIN)

PARAMETER		MIN	TYP	MAX	UNIT
tw(5)	Clock pulse duration, SCLK	High	20		ns
tw(6)		Low	20		
tc(3)	Clock period, SCLK	80			ns
tsu(4)	Clock rising edge to CS rising edge, SCLK	60			ns
tsu(5)	Setup time, SDIN to SCLK	20			ns
th(4)	Hold time, SCLK to SDIN	20			ns
tw(7)	Pulse duration, \overline{CS}	High	20		ns
tw(8)		Low	20		

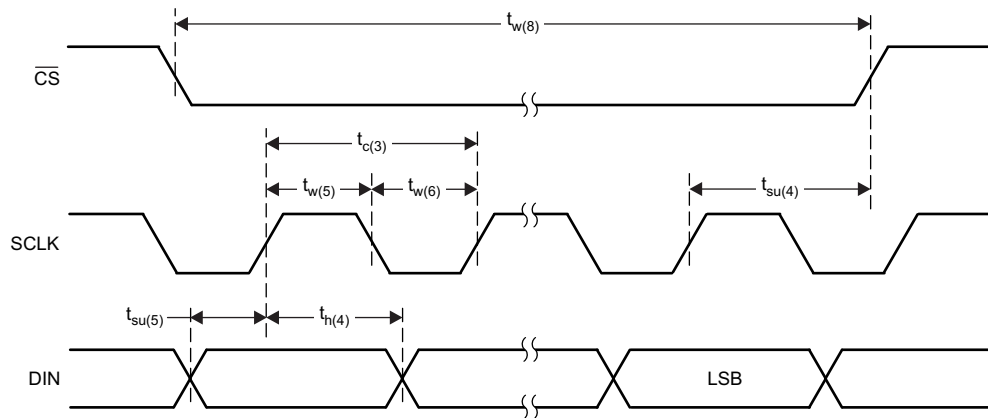

T0550-01

Figure 2-4. 3-Wire Control Interface Timing Requirements

2.4.4 2-Wire Control Interface

PARAMETER		MIN	TYP	MAX	UNIT
tw(9)	Clock pulse duration, SCLK	High	1.3		μs
tw(10)		Low	600		ns
f(sf)	Clock frequency, SCLK	0		400	kHz
th(5)	Hold time (start condition)	600			ns
tsu(6)	Setup time (start condition)	600			ns
th(6)	Data hold time			900	ns
tsu(7)	Data setup time	100			ns
tr	Rise time, SDIN, SCLK			300	ns
tf	Fall time, SDIN, SCLK			300	ns
tsu(8)	Setup time (stop condition)	600			ns
tsp	Pulse width of spikes suppressed by input filter		0	50	ns

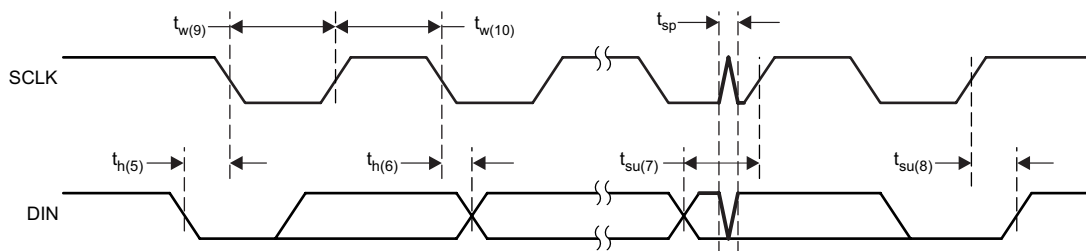

T0551-01

Figure 2-5. 2-Wire Control Interface Timing Requirements

3 How to Use the TLV320AIC23B-Q1

3.1 Control Interfaces

The TLV320AIC23B-Q1 has many programmable features. The control interface is used to program the registers of the device. The control interface complies with SPI (3-wire operation) and 2-wire operation specifications. The state of the MODE terminal selects the control interface type. The MODE pin must be hardwired to the required level.

MODE	INTERFACE
0	2-wire
1	SPI

3.1.1 SPI

In SPI mode, SDIN carries the serial data, SCLK is the serial clock and CS latches the data word into the TLV320AIC23B-Q1. The interface is compatible with microcontrollers and DSPs with an SPI interface.

A control word consists of 16 bits, starting with the MSB. The data bits are latched on the rising edge of SCLK. A rising edge on CS after the 16th rising clock edge latches the data word into the AIC (see Figure 3-1).

The control word is divided into two parts. The first part is the address block, the second part is the data block:

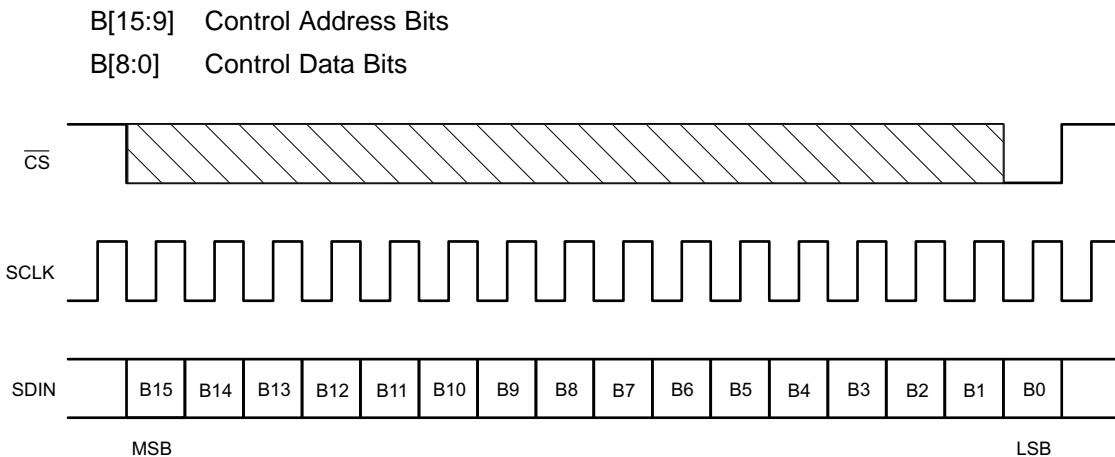

T0552-01

Figure 3-1. SPI Timing

3.1.2 2-Wire

In 2-wire mode, the data transfer uses SDIN for the serial data and SCLK for the serial clock. The start condition is a falling edge on SDIN while SCLK is high. The seven bits following the start condition determine which device on the 2-wire bus receives the data. R/W determines the direction of the data transfer. The TLV320AIC23B-Q1 is a write only device and responds only if R/W is 0. The device operates only as a slave device whose address is selected by setting the state of the CS pin as follows.

CS STATE (Default = 0)	ADDRESS
0	0011010
1	0011011

The device that recognizes the address responds by pulling SDIN low during the ninth clock cycle, acknowledging the data transfer. The control follows in the next two eight-bit blocks. The stop condition after the data transfer is a rising edge on SDIN when SCLK is high (see Figure 3-2).

The 16-bit control word is divided into two parts. The first part is the address block, the second part is the data block:

- B[15:9] Control Address Bits
- B[8:0] Control Data Bits

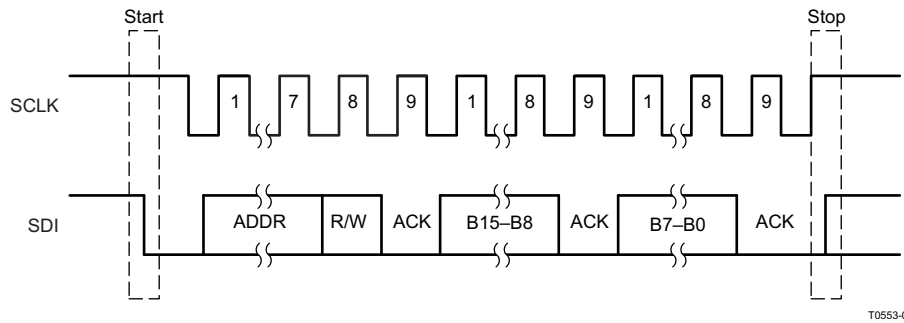

Figure 3-2. 2-Wire Compatible Timing

3.1.3 Register Map

The TLV320AIC23B-Q1 has the following set of registers, which are used to program the modes of operation. To minimize corruption and potential noise injection due to improper sequencing, program the registers while the device is powered down (Register 0x06, value 0x80). After the registers are programmed, power on the device (Register 0x06, value 0x28).

ADDRESS	REGISTER
0000000	Left line input channel volume control
0000001	Right line input channel volume control
0000010	Left channel headphone volume control
0000011	Right channel headphone volume control
0000100	Analog audio path control
0000101	Digital audio path control
0000110	Power down control
0000111	Digital audio interface format
0001000	Sample rate control
0001001	Digital interface activation
0001111	Reset register

Table 3-1. Left Line Input Channel Volume Control (Address: 0000000)

BIT	D8	D7	D6	D5	D4	D3	D2	D1	D0
Function	LRS	LIM	X	X	LIV4	LIV3	LIV2	LIV1	LIV0
Default	0	1	0	0	1	0	1	1	1

- LRS Left/right line simultaneous volume/mute update
Simultaneous update 0 = Disabled 1 = Enabled
- LIM Left line input mute 0 = Normal 1 = Muted
- LIV[4:0] Left line input volume control (10111 = 0 dB default)
11111 = 12 dB down to 00000 = -34.5 dB in 1.5-dB steps
- X Reserved

Table 3-2. Right Line Input Channel Volume Control (Address: 0000001)

BIT	D8	D7	D6	D5	D4	D3	D2	D1	D0
Function	RLS	RIM	X	X	RIV4	RIV3	RIV2	RIV1	RIV0
Default	0	1	0	0	1	0	1	1	1

RLS Right/left line simultaneous volume/mute update
 Simultaneous update 0 = Disabled 1 = Enabled
 RIM Right line input mute 0 = Normal 1 = Muted
 RIV[4:0] Right line input volume control (10111 = 0 dB default)
 11111 = 12 dB down to 00000 = -34.5 dB in 1.5-dB steps
 X Reserved

Table 3-3. Left Channel Headphone Volume Control (Address: 0000010)

BIT	D8	D7	D6	D5	D4	D3	D2	D1	D0
Function	LRS	LZC	LHV6	LHV5	LHV4	LHV3	LHV2	LHV1	LHV0
Default	0	1	1	1	1	1	0	0	1

LRS Left/right headphone channel simultaneous volume/mute update
 Simultaneous update 0 = Disabled 1 = Enabled
 LZC Left channel zero-cross detect
 Zero-cross detect 0 = Off 1 = On
 LHV[6:0] Left Headphone volume control (1111001 = 0 dB default)
 1111111 = 6 dB, 79 steps between 6 dB and -73 dB (mute), 0110000 = -73 dB (mute), anything below 0110000 does nothing – you are still muted

Table 3-4. Right Channel Headphone Volume Control (Address: 0000011)

BIT	D8	D7	D6	D5	D4	D3	D2	D1	D0
Function	RLS	RZC	RHV6	RHV5	RHV4	RHV3	RHV2	RHV1	RHV0
Default	0	1	1	1	1	1	0	0	1

LRS Right/left headphone channel simultaneous volume/mute update
 Simultaneous update 0 = Disabled 1 = Enabled
 RZC Right channel zero-cross detect
 Zero-cross detect 0 = Off 1 = On
 RHV[6:0] Right headphone volume control (1111001 = 0 dB default)
 1111111 = 6 dB, 79 steps between 6 dB and -73 dB (mute), 0110000 = -73 dB (mute), any thing below 0110000 does nothing – you are still muted

Table 3-5. Analog Audio Path Control (Address: 0000100)

BIT	D8	D7	D6	D5	D4	D3	D2	D1	D0
Function	STA2	STA1	STA0	STE	DAC	BYP	INSEL	MICM	MICB
Default	0	0	0	0	1	1	0	1	0

STA[2:0] and STE

	STE	STA2	STA1	STA0	ADDED SIDETONE
	1	1	X	X	0 dB
	1	0	0	0	-6 dB
	1	0	0	1	-9 dB
	1	0	1	0	-12 dB
	1	0	1	1	-18 dB
	0	X	X	X	Disabled

DAC	DAC select	0 = DAC off	1 = DAC selected
BYP	Bypass	0 = Disabled	1 = Enabled
INSEL	Input select for ADC	0 = Line	1 = Microphone
MICM	Microphone mute	0 = Normal	1 = Muted
MICB	Microphone boost	0 = dB	1 = 20 dB
X	Reserved		

Table 3-6. Digital Audio Path Control (Address: 0000101)

BIT	D8	D7	D6	D5	D4	D3	D2	D1	D0
Function	X	X	X	X	X	DACM	DEEMP1	DEEMP0	ADCHP
Default	0	0	0	0	0	0	1	0	0

DACM	DAC soft mute	0 = Disabled	1 = Enabled		
DEEMP[1:0]	De-emphasis control	00 = Disabled	01 = 32 kHz	10 = 44.1 kHz	11 = 48 kHz
ADCHP	ADC high-pass filter	1 = Disabled	0 = Enabled		
X	Reserved				

Table 3-7. Power Down Control (Address: 0000110)

BIT	D8	D7	D6	D5	D4	D3	D2	D1	D0
Function	X	OFF	CLK	OSC	OUT	DAC	ADC	MIC	LINE
Default	0	0	0	0	0	0	1	1	1

OFF	Device power	0 = On	1 = Off
CLK	Clock	0 = On	1 = Off
OSC	Oscillator	0 = On	1 = Off
OUT	Outputs	0 = On	1 = Off
DAC	DAC	0 = On	1 = Off
ADC	ADC	0 = On	1 = Off
MIC	Microphone input	0 = On	1 = Off
LINE	Line input	0 = On	1 = Off
X	Reserved		

Table 3-8. Digital Audio Interface Format (Address: 0000111)

BIT	D8	D7	D6	D5	D4	D3	D2	D1	D0
Function	X	X	MS	LRSWAP	LRP	IWL1	IWL0	FOR1	FOR0
Default	0	0	0	0	0	0	0	0	1

MS Maser/slave mode 0 = Slave 1 = Master
 LRSWAP DAC left/right swap 0 = Disabled 1 = Enabled
 LRP DAC left/right phase 0 = Right channel on, LRCIN high
 1 = Right channel on, LRCIN low
 DSP mode
 1 = MSB is available on second BCLK rising edge after LRCIN rising edge
 0 = MSB is available on first BCLK rising edge after LRCIN rising edge
 IWL[1:0] Input bit length 00 = 16 bit 01 = 20 bit 10 = 24 bit 11 = 32 bit
 FOR[1:0] Data format 11 = DSP format, frame sync followed by two data words
 10 = I²S format, MSB first, left – 1 aligned
 01 = MSB first, left aligned
 00 = MSB first, right aligned

X Reserved

- NOTES: 1. In master mode, the TLV320AIC23B-Q1 supplies the BCLK, LRCOUT, and LRCIN. In slave mode, BCLK, LRCOUT, and LRCIN are supplied to the TLV320AIC23B-Q1.
 2. In normal mode, BCLK = MCLK/4 for all sample rates except for 88.2 kHz and 96 kHz. For 88.2 kHz and 96 kHz sample rate, BCLK = MCLK.
 3. In USB mode, bit BCLK = MCLK

Table 3-9. Sample Rate Control (Address: 0001000)

BIT	D8	D7	D6	D5	D4	D3	D2	D1	D0
Function	X	CLKOUT	CLKIN	SR3	SR2	SR1	SR0	BOSR	USB/Normal
Default	0	0	0	1	0	0	0	0	0

CLKIN Clock input divider 0 = MCLK 1 = MCLK/2
 CLKOUT Clock output divider 0 = MCLK 1 = MCLK/2
 SR[3:0] Sampling rate control (see Section 3.3.2.1 and Section 3.3.2.2)
 BOSR Base oversampling rate
 USB mode: 0 = 250 f_s 1 = 272 f_s
 Normal mode: 0 = 256 f_s 1 = 384 f_s
 USB/Normal Clock mode select: 0 = Normal 1 = USB
 X Reserved

Table 3-10. Digital Interface Activation (Address: 0001001)

BIT	D8	D7	D6	D5	D4	D3	D2	D1	D0
Function	X	RES	RES	X	X	X	X	X	ACT
Default	0	0	0	0	0	0	0	0	0

ACT Activate interface 0 = Inactive 1 = Active
 X Reserved

Table 3-11. Reset Register (Address: 0001111)

BIT	D8	D7	D6	D5	D4	D3	D2	D1	D0
Function	RES	RES	RES	RES	RES	RES	RES	RES	RES
Default	0	0	0	0	0	0	0	0	0

RES Write 00000000 to this register triggers reset

3.2 Analog Interface

3.2.1 Line Inputs

The TLV320AIC23B-Q1 has line inputs for the left and the right audio channels (RLINEIN and LLINEIN). Both line inputs have independently programmable volume controls and mutes. Active and passive filters for the two channels prevent high frequencies from folding back into the audio band.

The line-input gain is logarithmically adjustable from 12 dB to –34.5 dB in 1.5-dB steps. The ADC full-scale range is 1 V_{RMS} at $AV_{DD} = 3.3$ V. The full-scale range tracks linearly with analog supply voltage AV_{DD} . To avoid distortions, it is important not to exceed the full-scale range.

The gain is independently programmable on both left and right line-inputs. To reduce the number of software write cycles required, both channels can be locked to the same value by setting the RLS and LRS bits (see Section 3.1.3).

The line inputs are biased internally to VMID. When the line inputs are muted or the device is set to standby mode, the line inputs are kept biased to VMID using special antithump circuitry. This reduces audible clicks that otherwise might be heard when reactivating the inputs.

For interfacing to a CD system, the line input should be scaled to 1 V_{RMS} to avoid clipping, using the circuit shown in Figure 3-3.

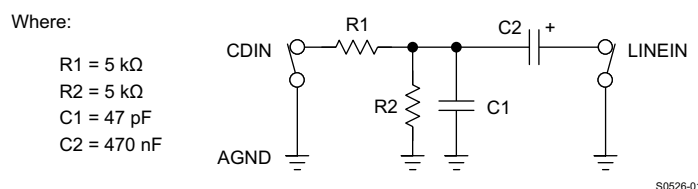

Figure 3-3. Analog Line Input Circuit

R1 and R2 divide the input signal by two, reducing the 2 V_{RMS} from the CD player to the nominal 1 V_{RMS} of the AIC23B inputs. The C1 filters high-frequency noise, and C2 removes any dc component from the signal.

3.2.2 Microphone Input

MICIN is a high-impedance, low-capacitance input that is compatible with a wide range of microphones. It has a programmable volume control and a mute function. Active and passive filters prevent high frequencies from folding back into the audio band.

The MICIN signal path has two gain stages. The first stage has a nominal gain of $G1 = 50\text{ k}/10\text{ k} = 5$. By adding an external resistor (R_{MIC}) in series with MICIN, the gain of the first stage can be adjusted by $G1 = 50\text{ k}/(10\text{ k} + R_{MIC})$. For example, $R_{MIC} = 40\text{ k}$ gives a gain of 0 dB. The second stage has a software programmable gain of 0 dB or 20 dB (see Section 3.1.3).

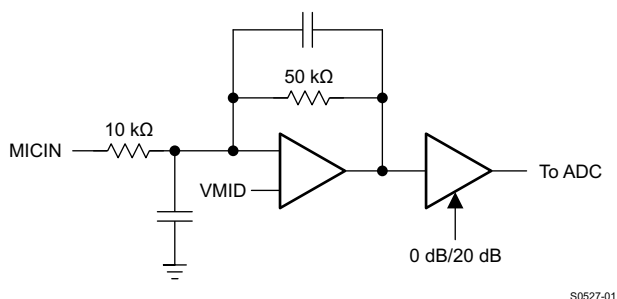

Figure 3-4. Microphone Input Circuit

The microphone input is biased internally to VMID. When the line inputs are muted, the MICIN input is kept biased to VMID using special antithump circuitry. This reduces audible clicks that may otherwise be heard when reactivating the input.

The MICBIAS output provides a low-noise reference voltage suitable for biasing electret type microphones and the associated external resistor biasing network. The maximum source current capability is 3 mA. This limits the smallest value of external biasing resistors that safely can be used.

The MICBIAS output is not active in standby mode.

3.2.3 Line Outputs

The TLV320AIC23B-Q1 has two low-impedance line outputs (LLINEOUT and RLINEOUT) capable of driving line loads with 10-k Ω and 50-pF impedances.

The DAC full-scale output voltage is 1 V_{RMS} at $AV_{DD} = 3.3$ V. The full-scale range tracks linearly with the analog supply voltage AV_{DD} . The DAC is connected to the line outputs via a low-pass filter that removes out-of-band components. No further external filtering is required in most applications.

The DAC outputs, line inputs, and the microphone signal are summed into the line outputs. These sources can be switched off independently. For example, in bypass mode, the line inputs are routed to the line outputs, bypassing the ADC and the DAC. If sidetone is enabled, the microphone signal is routed to both line outputs via a four-step programmable attenuation circuit.

The line outputs are muted by either muting the DAC (analog) or soft muting (digital) and disabling the bypass and sidetone paths (see [Section 3.1.3](#)).

3.2.4 Headphone Output

The TLV320AIC23B-Q1 has stereo headphone outputs (LHPOUT and RHPOUT), and is designed to drive 16- Ω or 32- Ω headphones. The headphone output includes a high-quality volume control and mute function.

The headphone volume is logarithmically adjustable from 6 dB to –73 dB in 1-dB steps. Writing 000000 to the volume-control registers (see [Section 3.1.3](#)) mutes the headphone output. When the headphone output is muted or the device is placed in standby mode, the dc voltage is maintained at the outputs to prevent audible clicks.

A zero-cross detection circuit is provided under the control of the LZC and RZC bits. If this circuit is enabled, the volume-control values are updated only when the input signal to the gain stage is close to the analog ground level.

This minimizes audible clicks as the volume is changed or the device is muted. This circuit has no time-out, so, if only dc levels are being applied to the gain stage input of more than 20 mV, the gain is not updated.

The gain is independently programmable on the left and right channels. Both channels can be locked to the same value by setting the RLS and LRS bits (see [Section 3.1.3](#)).

3.2.5 Analog Bypass Mode

The TLV320AIC23B-Q1 includes a bypass mode in which the analog line inputs are directly routed to the analog line outputs, bypassing the ADC and DAC. This is enabled by selecting the bypass bit in the analog audio path control register (see [Section 3.1.3](#)).

For a true bypass mode, the output from the DAC and the sidetone should be disabled. The line input and headphone output volume controls and mutes are still operational in bypass mode. Therefore the line inputs, DAC output, and microphone input can be summed together. The maximum signal at any point in the bypass path must be no greater than 1 V_{RMS} at $AV_{DD} = 3.3$ V to avoid clipping and distortion. This amplitude tracks linearly with AV_{DD} .

3.2.6 Sidetone Insertion

The TLV320AIC23B-Q1 has a sidetone insertion made where the microphone input is routed to the line and headphone outputs. This is useful for telephony and headset applications. The attenuation of the sidetone signal may be set to -6 dB, -9 dB, -12 dB, -15 dB, or 0 dB, by software selection (see [Section 3.1.3](#)). If this mode is used to sum the microphone input with the DAC output and line inputs, care must be taken not to exceed signal level to avoid clipping and distortion.

3.3 Digital Audio Interface

3.3.1 Digital Audio-Interface Modes

The TLV320AIC23B-Q1 supports four audio-interface modes.

- Right justified
- Left justified
- I²S mode
- DSP mode

The four modes are MSB first and operate with a variable word width between 16 to 32 bits (except right-justified mode, which does not support 32 bits).

The digital audio interface consists of clock signal BCLK, data signals DIN and DOUT, and synchronization signals LRCIN and LRCOUT. BCLK is an output in master mode and an input in slave mode.

3.3.1.1 Right-Justified Mode

In right-justified mode, the LSB is available on the rising edge of BCLK, preceding a falling edge on LRCIN or LRCOUT (see [Figure 3-5](#)).

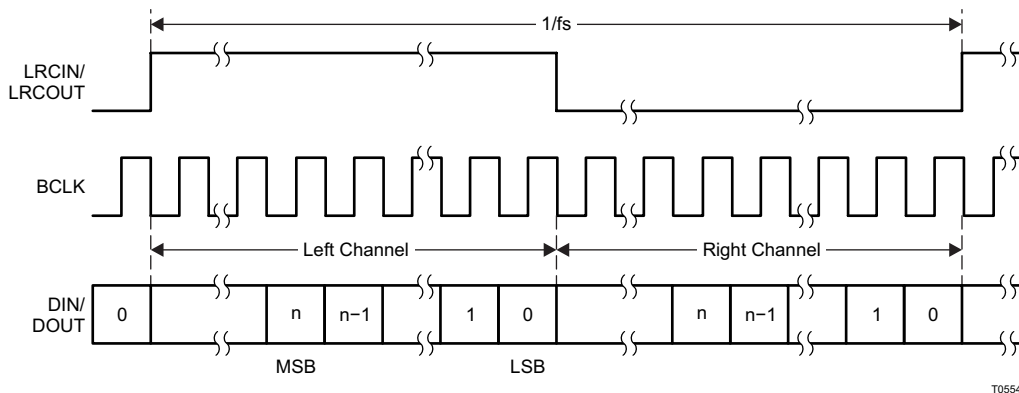

Figure 3-5. Right-Justified Mode Timing

3.3.1.2 Left-Justified Mode

In left-justified mode, the MSB is available on the rising edge of BCLK, following a rising edge on LRCIN or LRCOUT (see [Figure 3-6](#)).

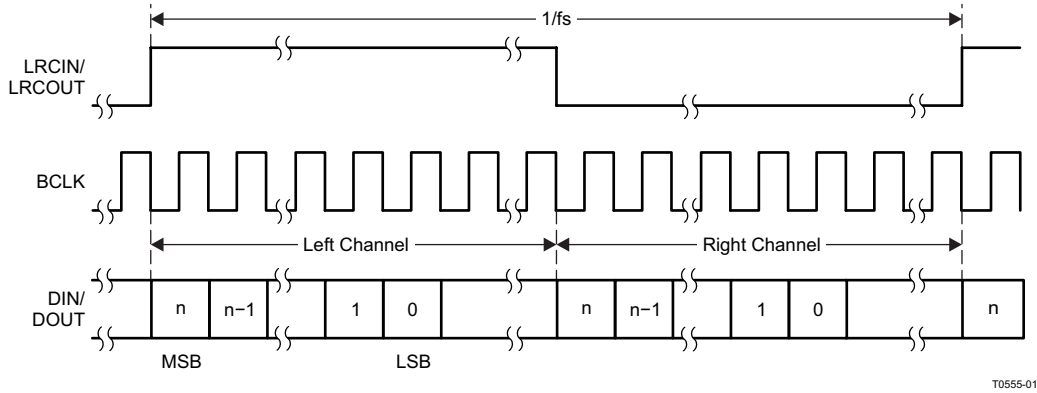

Figure 3-6. Left-Justified Mode Timing

3.3.1.3 I²S Mode

In I²S mode, the MSB is available on the second rising edge of BCLK, after the falling edge on LRCIN or LRCOUT (see Figure 3-7).

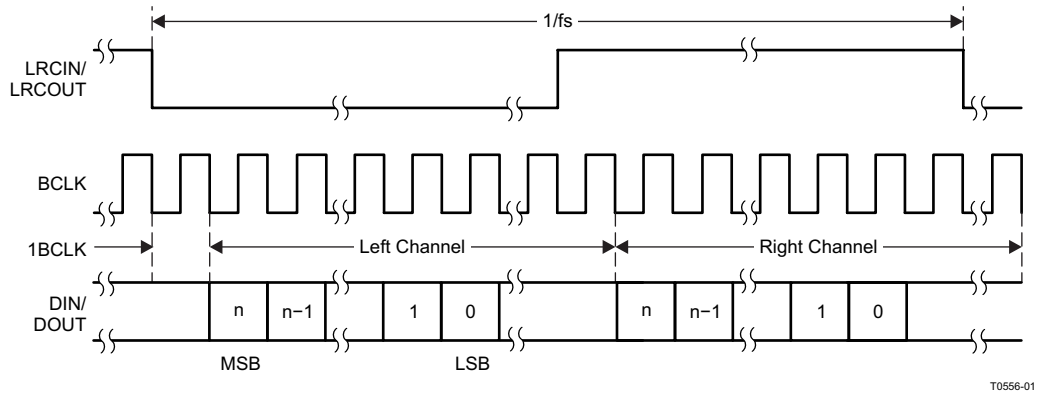

Figure 3-7. I²S Mode Timing

3.3.1.4 DSP Mode

The DSP mode is compatible with the McBSP ports of TI DSPs. LRCIN and LRCOUT must be connected to the Frame Sync signal of the McBSP. A falling edge on LRCIN or LRCOUT starts the data transfer. The left-channel data consists of the first data word, which is immediately followed by the right channel data word (see Figure 3-8). Input word length is defined by the IWL register. Figure 3-8 shows LRP = 1 (default LRP = 0).

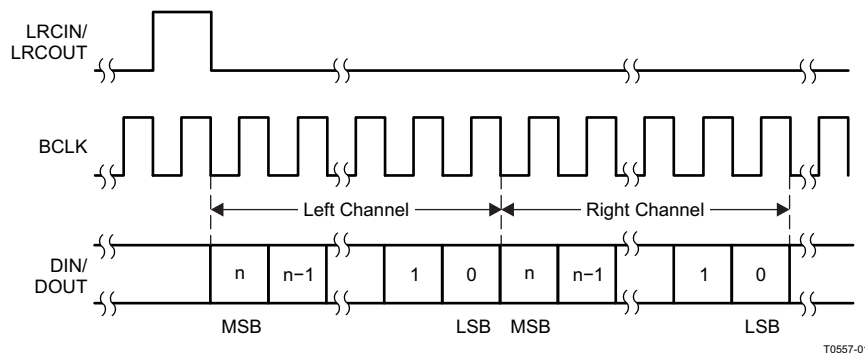

Figure 3-8. DSP Mode Timing

3.3.2 Audio Sampling Rates

The TLV320AIC23B-Q1 can operate in master or slave clock mode. In the master mode, the TLV320AIC23B-Q1 clock and sampling rates are derived from a 12-MHz MCLK signal. This 12-MHz clock signal is compatible with the USB specification. The TLV320AIC23B-Q1 can be used directly in a USB system.

In the slave mode, an appropriate MCLK or crystal frequency and the sample rate control register settings control the TLV320AIC23B-Q1 clock and sampling rates.

The settings in the sample rate control register control the clock mode and sampling rates.

Table 3-12. Sample Rate Control (Address: 0001000)

BIT	D8	D7	D6	D5	D4	D3	D2	D1	D0
Function	X	CLKOUT	CLKIN	SR3	SR2	SR1	SR0	BOSR	USB/Normal
Default	0	0	0	1	0	0	0	0	0

CLKIN	Clock input divider	0 = MCLK	1 = MCLK/2
CLKOUT	Clock output divider	0 = MCLK	1 = MCLK/2
SR[3:0]	Sampling rate control (see Sections 3.3.2.1 AND 3.3.2.2)		
BOSR	Base oversampling rate		
	USB mode:	0 = 250 f_s	1 = 272 f_s
	Normal mode:	0 = 256 f_s	1 = 384 f_s
USB/Normal	Clock mode select:	0 = Normal	1 = USB
X	Reserved		

The clock circuit of the AIC23B has two internal dividers. The first, controlled by CLKIN, applies to the sampling-rate generator of the codec. The second, controlled by CLKOUT, applies only to the CLKOUT terminal. By setting CLKIN to 1, the entire codec is clocked with half the frequency, effectively dividing the resulting sampling rates by two. The following sampling-rate tables are based on CLKIN = MCLK.

3.3.2.1 USB-Mode Sampling Rates (MCLK = 12 MHz)

In the USB mode, the following ADC and DAC sampling rates are available:

SAMPLING RATE ⁽¹⁾		FILTER TYPE	SAMPLING-RATE CONTROL SETTINGS				
ADC (kHz)	DAC (kHz)		SR3	SR2	SR1	SR0	BOSR
96	96	3	0	1	1	1	0
88.2	88.2	2	1	1	1	1	1
48	48	0	0	0	0	0	0
44.1	44.1	1	1	0	0	0	1
32	32	0	0	1	1	0	0
8.021	8.021	1	1	0	1	1	1
8	8	0	0	0	1	1	0
48	8	0	0	0	0	1	0
44.1	8.021	1	1	0	0	1	1
8	48	0	0	0	1	0	0
8.021	44.1	1	1	0	1	0	1

(1) The sampling rates are derived from the 12-MHz master clock. The available oversampling rates do not produce exactly 8-kHz, 44.1-kHz, and 88.2-kHz sampling rates, but 8.021 kHz, 44.117 kHz, and 88.235 kHz, respectively. See [Figure 3-9](#) through [Figure 3-26](#) for filter responses.

3.3.2.2 Normal-Mode Sampling Rates

In normal mode, the following ADC and DAC sampling rates, depending on the MCLK frequency, are available:

MCLK = 12.288 MHz

SAMPLING RATE		FILTER TYPE	SAMPLING-RATE CONTROL SETTINGS				
ADC (kHz)	DAC (kHz)		SR3	SR2	SR1	SR0	BOSR
96	96	2	0	1	1	1	0
48	48	1	0	0	0	0	0
32	32	1	0	1	1	0	0
8	8	1	0	0	1	1	0
48	8	1	0	0	0	1	0
8	48	1	0	0	1	0	0

MCLK = 11.2896 MHz

SAMPLING RATE		FILTER TYPE	SAMPLING-RATE CONTROL SETTINGS				
ADC (kHz)	DAC (kHz)		SR3	SR2	SR1	SR0	BOSR
88.2	88.2	2	1	1	1	1	0
44.1	44.1	1	1	0	0	0	0
8.021	8.021	1	1	0	1	1	0
44.1	8.021	1	1	0	0	1	0
8.021	44.1	1	1	0	1	0	0

MCLK = 18.432 MHz

SAMPLING RATE		FILTER TYPE	SAMPLING-RATE CONTROL SETTINGS				
ADC (kHz)	DAC (kHz)		SR3	SR2	SR1	SR0	BOSR
96	96	2	0	1	1	1	1
48	48	1	0	0	0	0	1
32	32	1	0	1	1	0	1
8	8	1	0	0	1	1	1
48	8	1	0	0	0	1	1
8	48	1	0	0	1	0	1

MCLK = 16.9344 MHz

SAMPLING RATE		FILTER TYPE	SAMPLING-RATE CONTROL SETTINGS				
ADC (kHz)	DAC (kHz)		SR3	SR2	SR1	SR0	BOSR
88.2	88.2	2	1	1	1	1	1
44.1	44.1	1	1	0	0	0	1
8.021	8.021	1	1	0	1	1	1
44.1	8.021	1	1	0	0	1	1
8.021	44.1	1	1	0	1	0	1

3.3.3 Digital Filter Characteristics

PARAMETER	TEST CONDITIONS	MIN	TYP	MAX	UNIT
ADC Filter Characteristics (TI DSP 250 f_s Mode Operation)					
Passband	±0.05 dB	0.416 f _s			Hz
Stopband	−6 dB	0.5 f _s			Hz
Passband ripple				±0.05	dB
Stopband attenuation	f > 0.584 f _s			−60	dB
ADC Filter Characteristics (TI DSP 272 f_s and Normal Mode Operation)					
Passband	±0.05 dB	0.4535 f _s			Hz
Stopband	−6 dB	0.5 f _s			Hz
Passband ripple				±0.05	dB
Stopband attenuation	f > 0.5465 f _s			−60	dB

PARAMETER	TEST CONDITIONS	MIN	TYP	MAX	UNIT
ADC High-Pass Filter Characteristics					
Corner frequency	-3 dB, $f_s = 44.1$ kHz		3.7		Hz
	-3 dB, $f_s = 48$ kHz		4		Hz
	-0.5 dB, $f_s = 44.1$ kHz		10.4		Hz
	-0.5 dB, $f_s = 48$ kHz		11.3		Hz
	-0.1 dB, $f_s = 44.1$ kHz		21.6		Hz
	-0.1 dB, $f_s = 48$ kHz		23.5		Hz
DAC Filter Characteristics (48-kHz Sampling Rate)					
Passband	± 0.03 dB	0.416 f_s			Hz
Stopband	-6 dB	0.5 f_s			Hz
Passband ripple				± 0.03	dB
Stopband attenuation	$f > 0.584 f_s$	-50			dB
DAC Filter Characteristics (44.1-kHz Sampling Rate)					
Passband	± 0.03 dB	0.4535 f_s			Hz
Stopband	-6 dB	0.5 f_s			Hz
Passband ripple				± 0.03	dB
Stopband attenuation	$f > 0.5465 f_s$	-50			dB

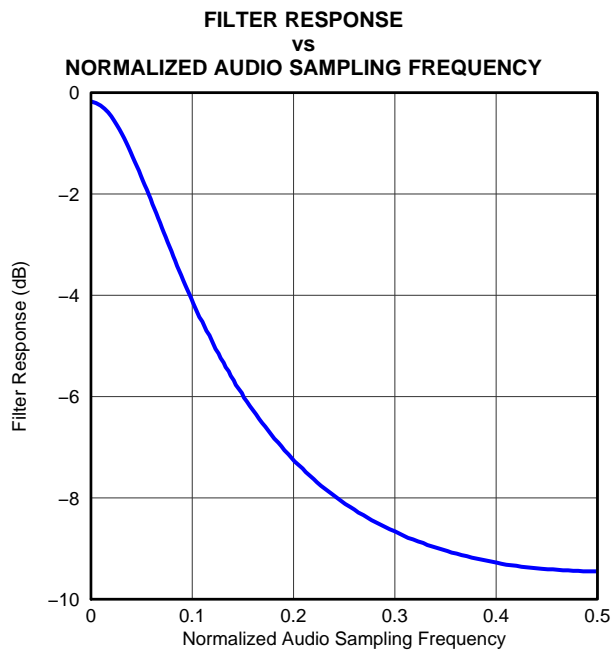

Figure 3-9. Digital De-Emphasis Filter Response – 44.1 kHz Sampling

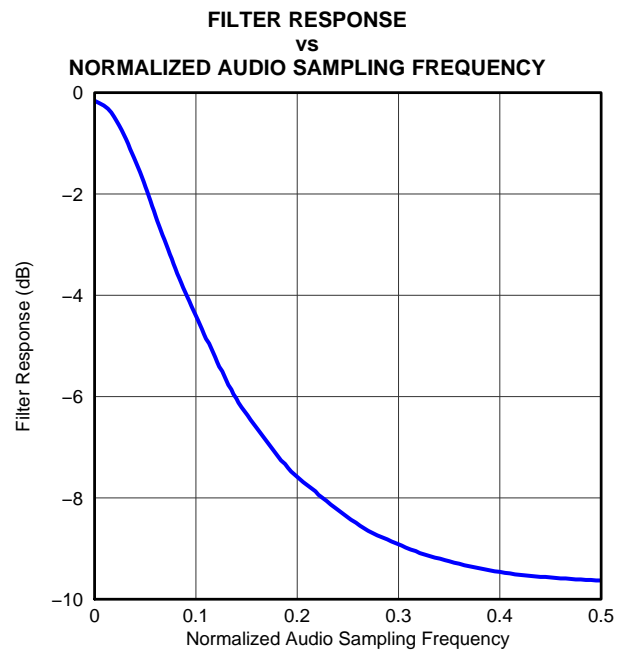

Figure 3-10. Digital De-Emphasis Filter Response – 48 kHz Sampling

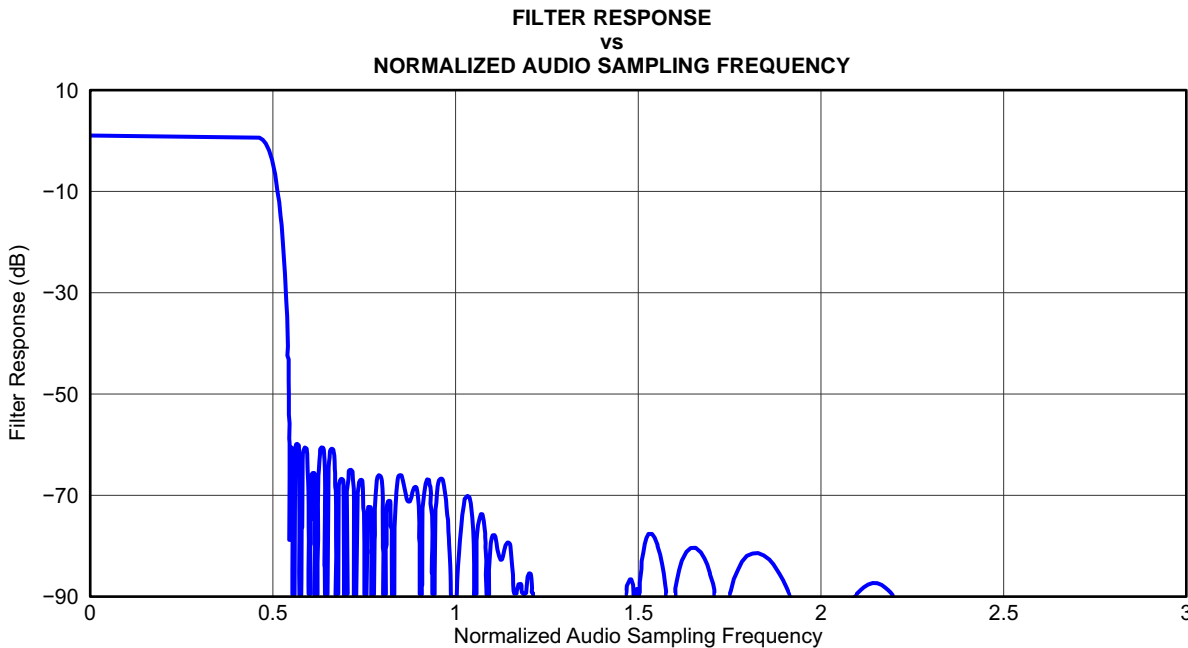

Figure 3-11. ADC Digital Filter Response 0: USB Mode (Group Delay = 12 Output Samples) G003

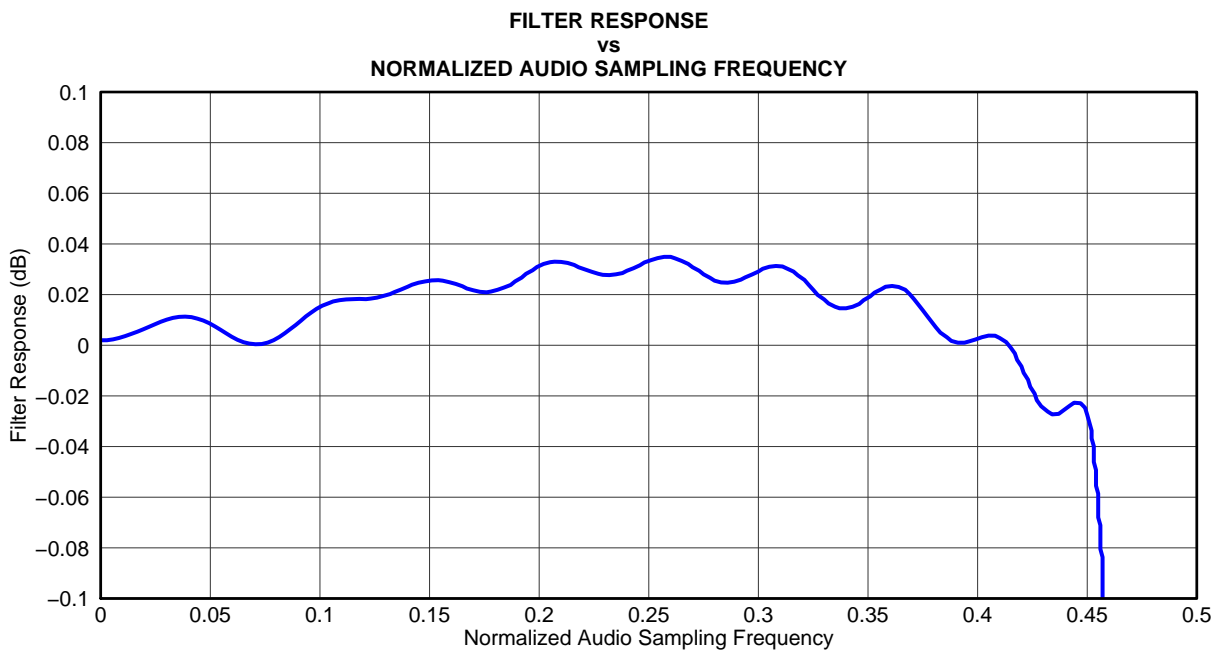

Figure 3-12. ADC Digital Filter Ripple 0: USB (Group Delay = 20 Output Samples) G004

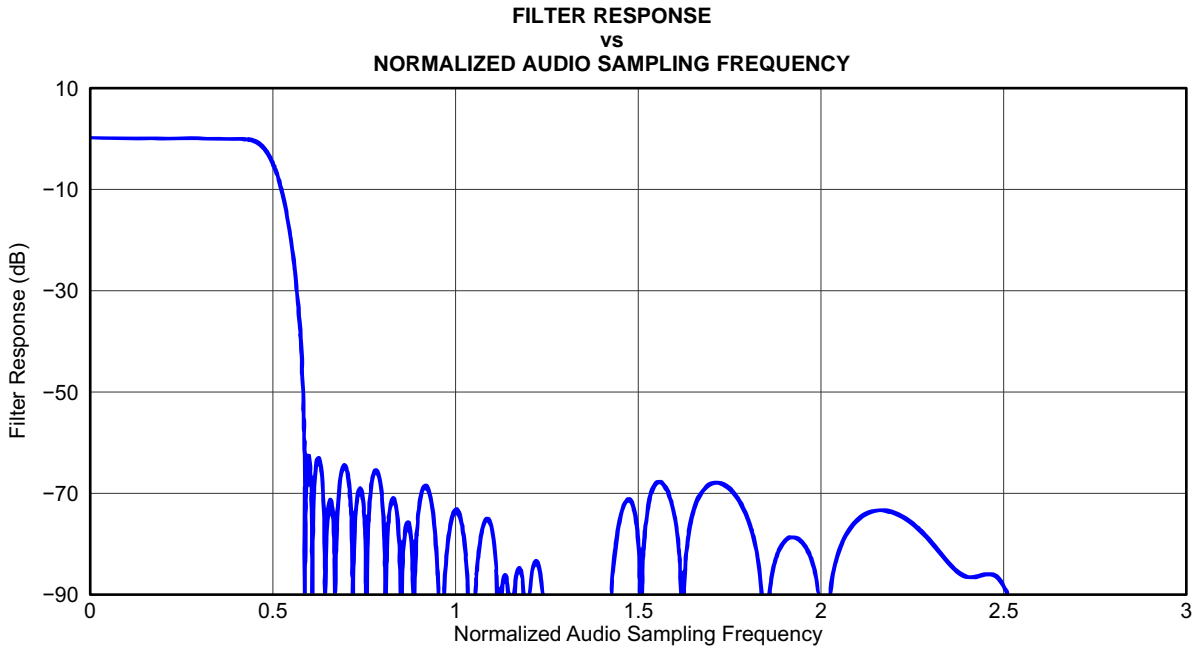

Figure 3-13. ADC Digital Filter Response 1: USB Mode Only

G005

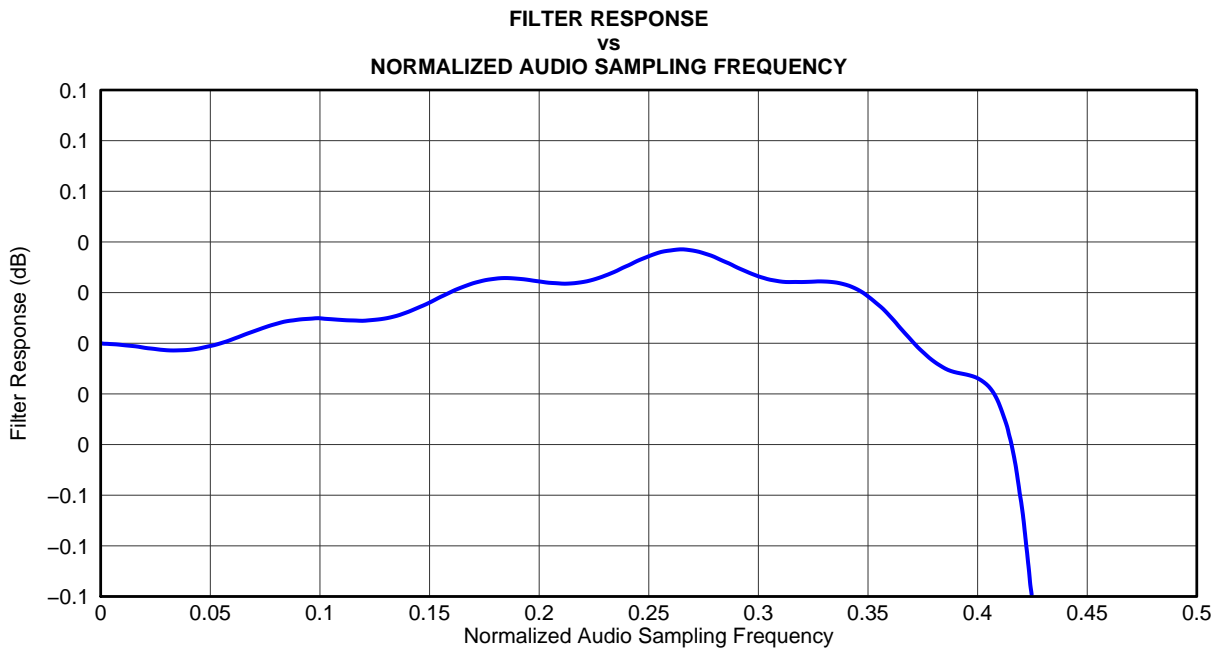

Figure 3-14. ADC Digital Filter Ripple 1: USB Mode Only

G006

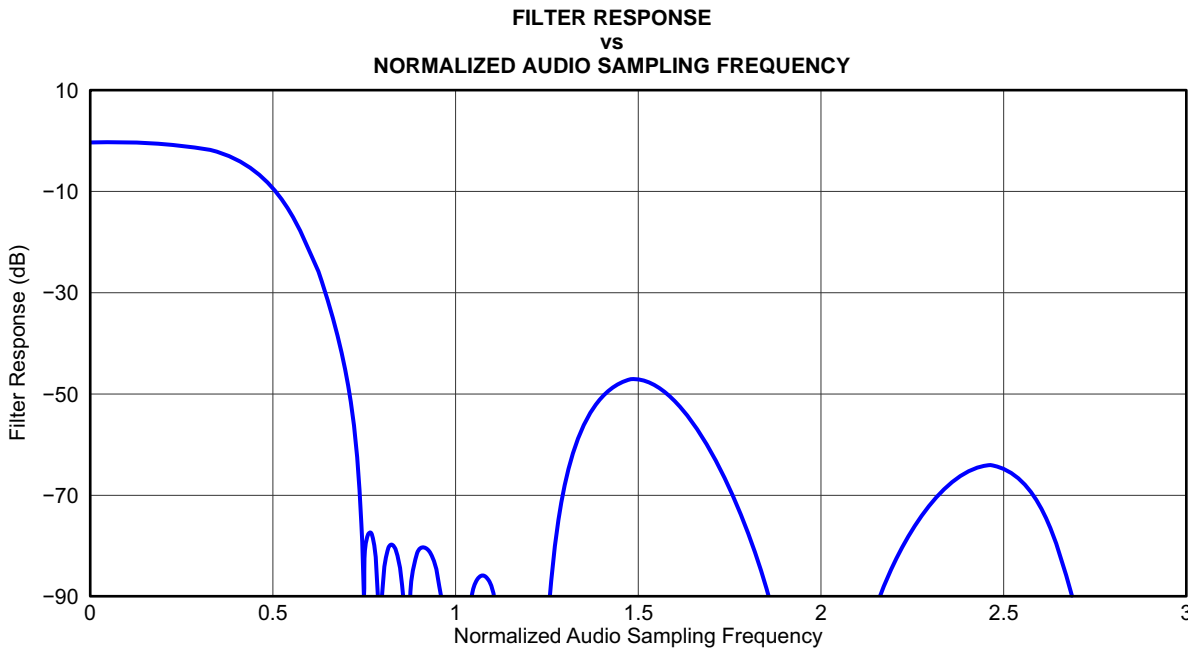

Figure 3-15. ADC Digital Filter Response 2: USB Mode and Normal Modes (Group Delay = 3 Output Samples)

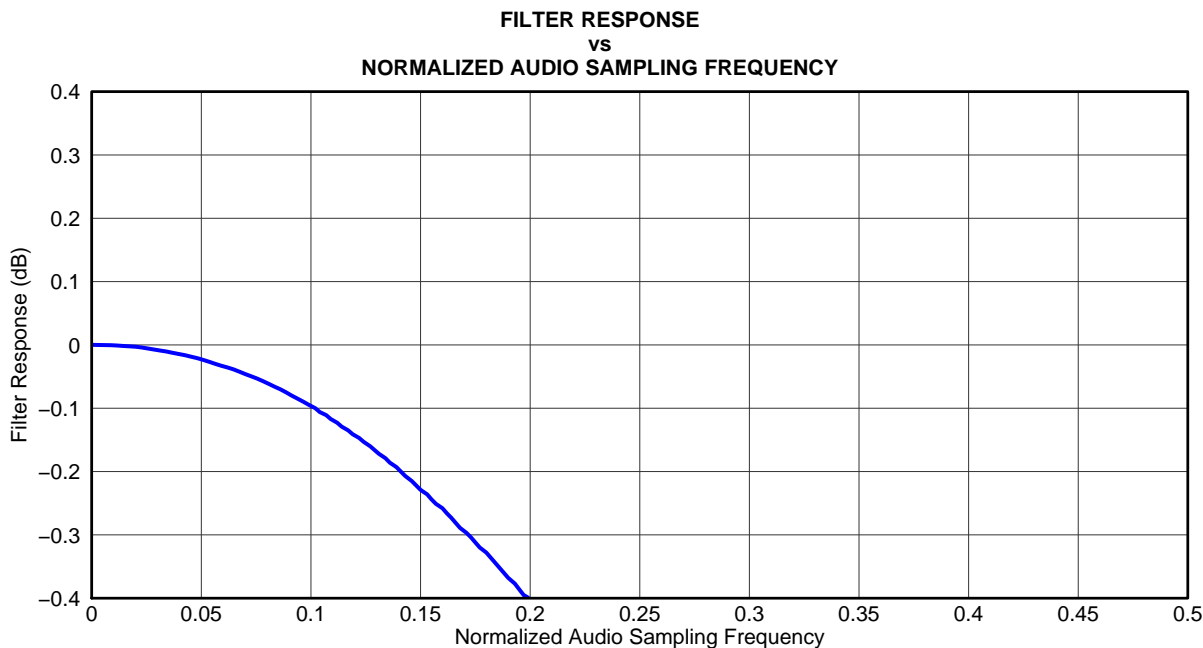

Figure 3-16. ADC Digital Filter Ripple 2: USB Mode and Normal Modes

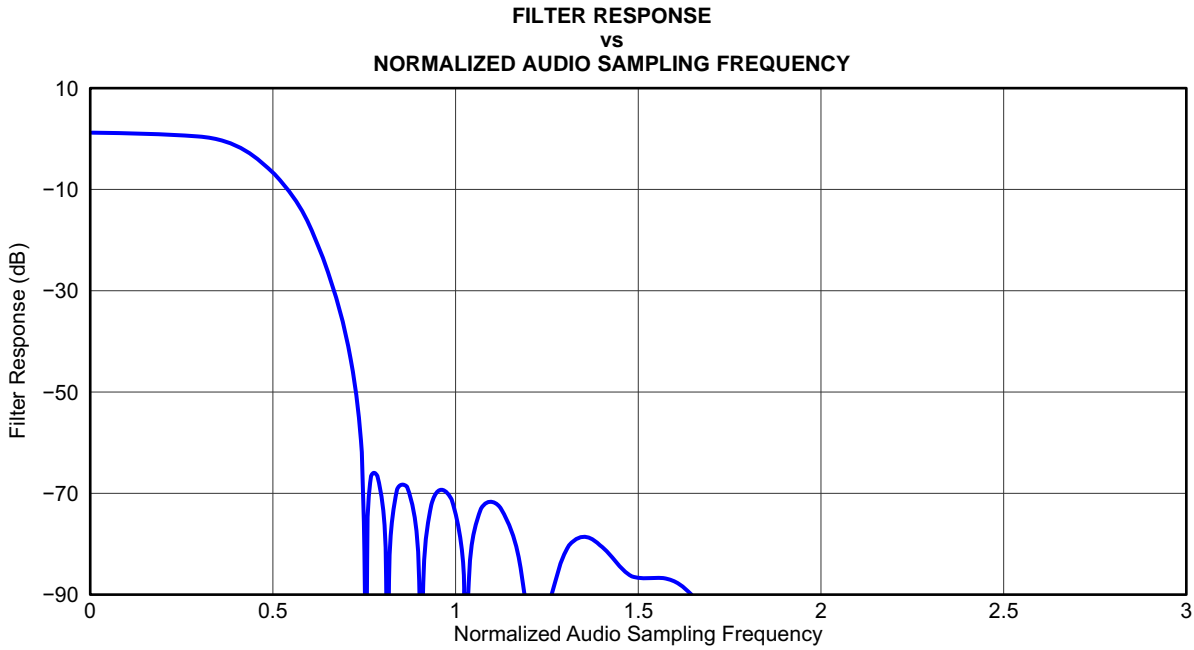

Figure 3-17. ADC Digital Filter Response 3: USB Mode Only

G009

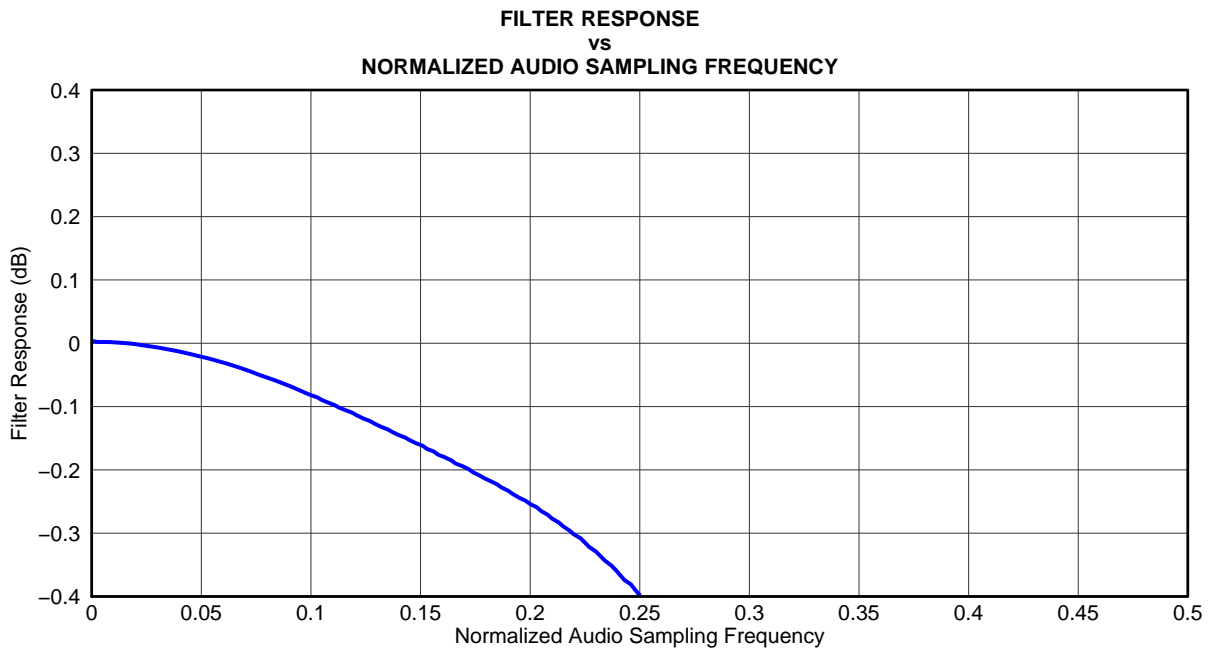
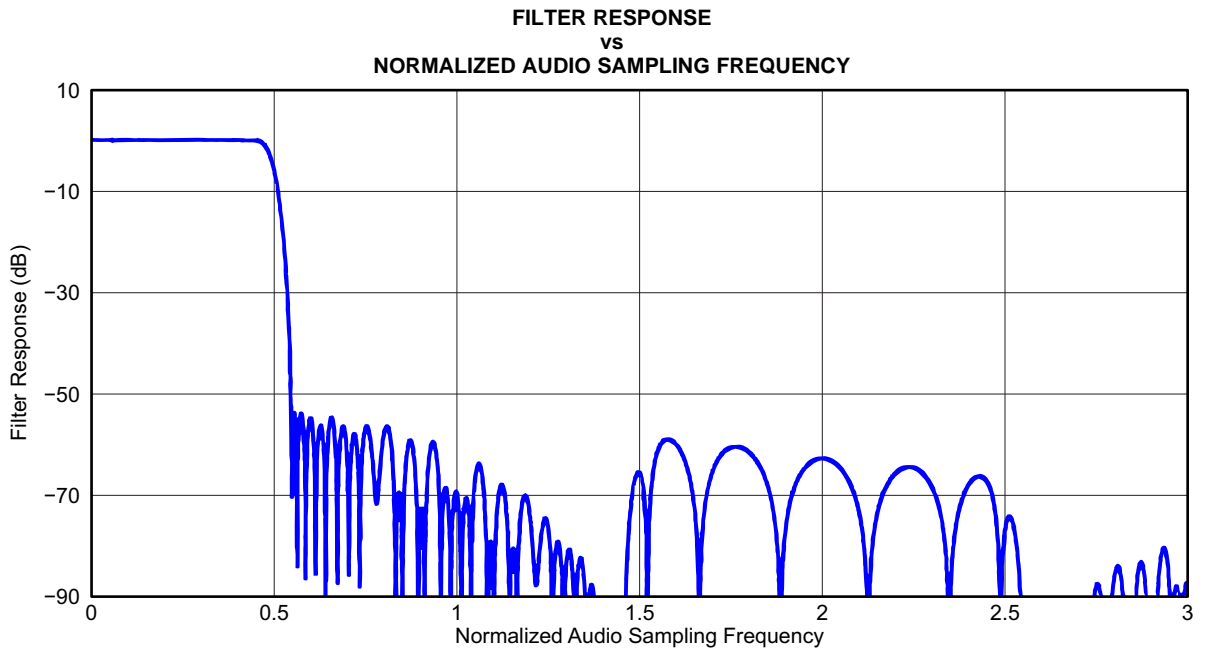

Figure 3-18. ADC Digital Filter Ripple 3: USB Mode Only

G010



G011

Figure 3-19. DAC Digital Filter Response 0: USB Mode

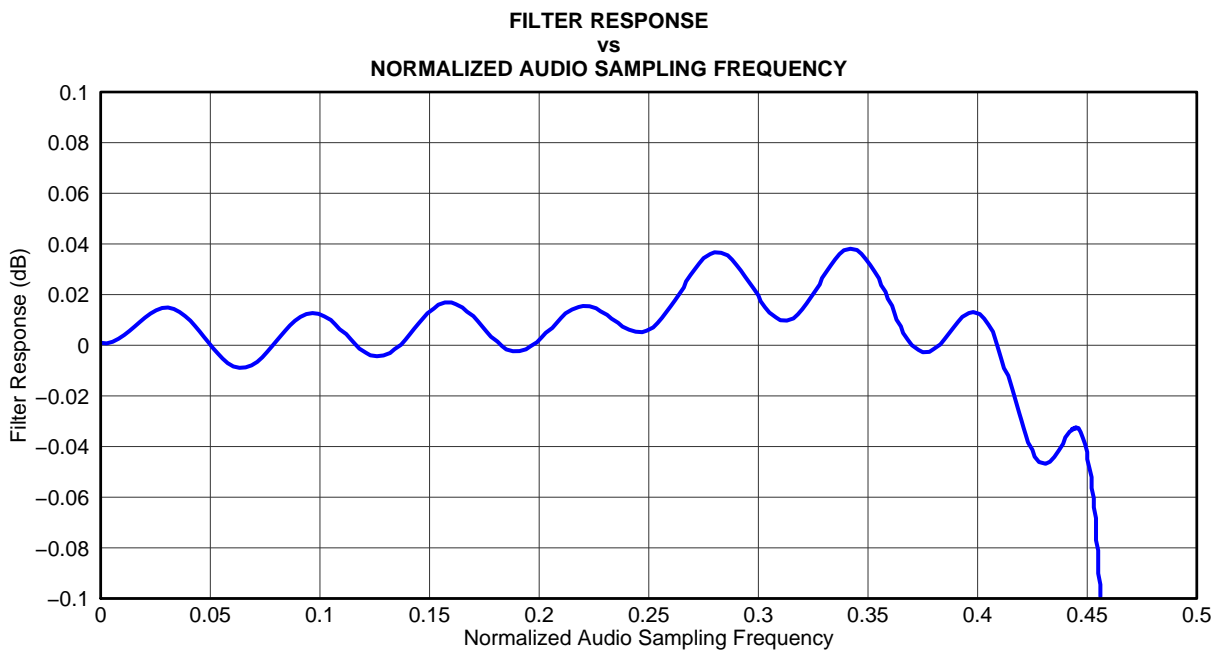

G012

Figure 3-20. DAC Digital Filter Ripple 0: USB Mode

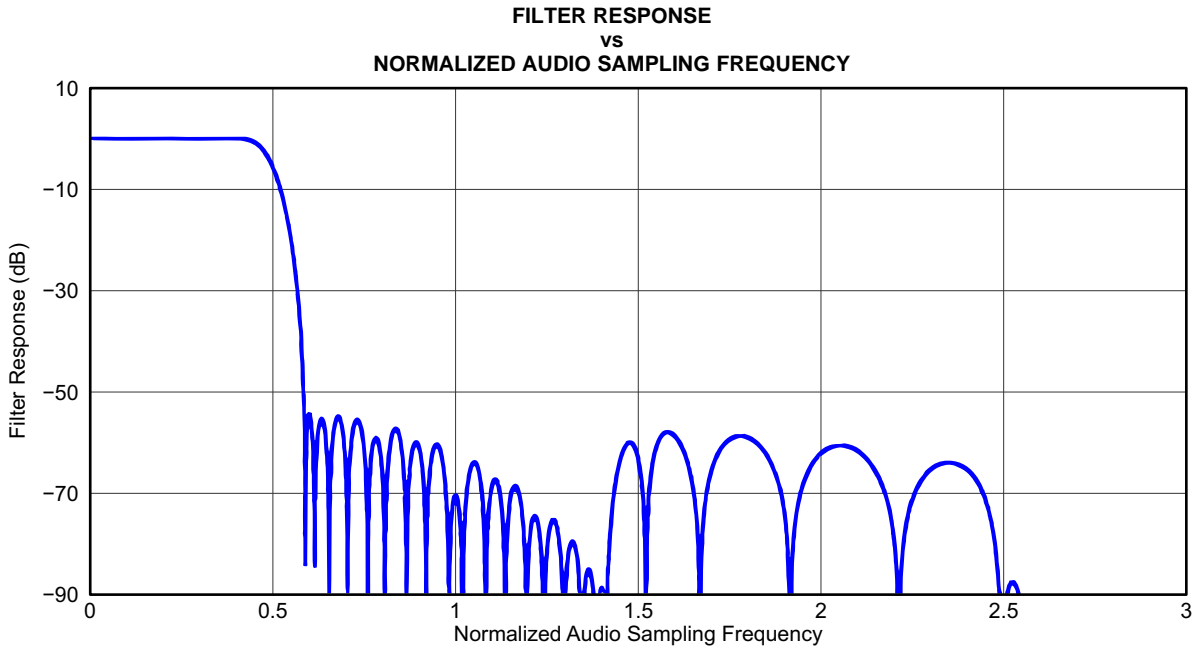

Figure 3-21. DAC Digital Filter Response 1: USB Mode Only

G013

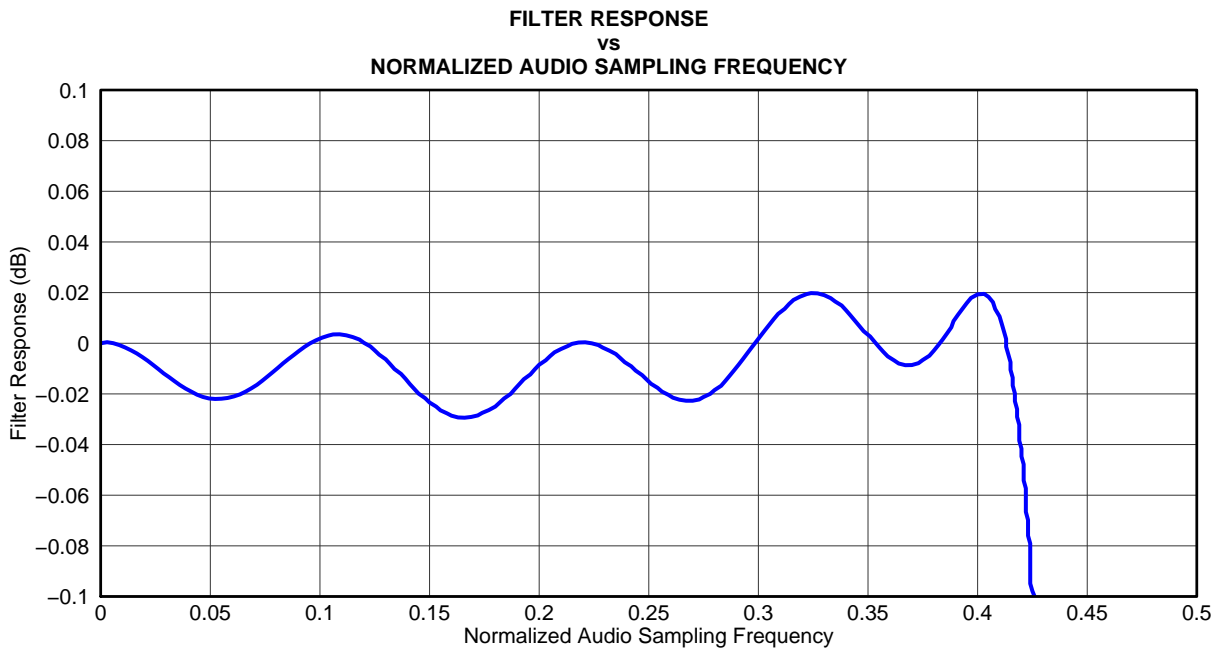

Figure 3-22. DAC Digital Filter Ripple 1: USB Mode Only

G014

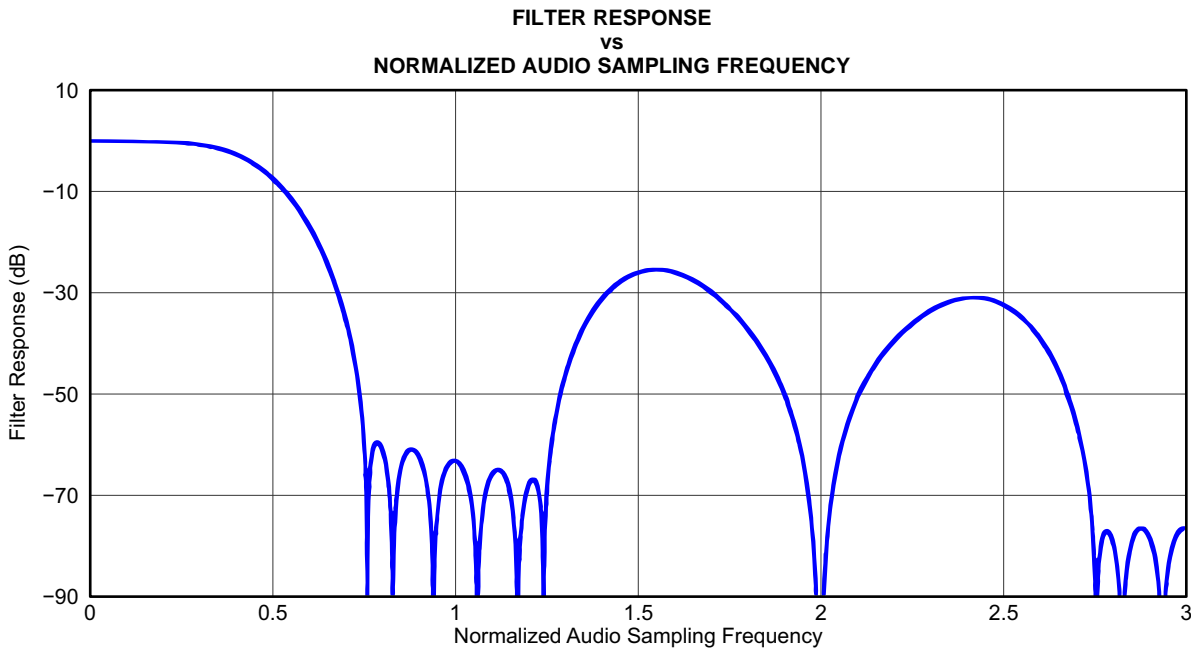

Figure 3-23. DAC Digital Filter Response 2: USB Mode and Normal Modes

G015

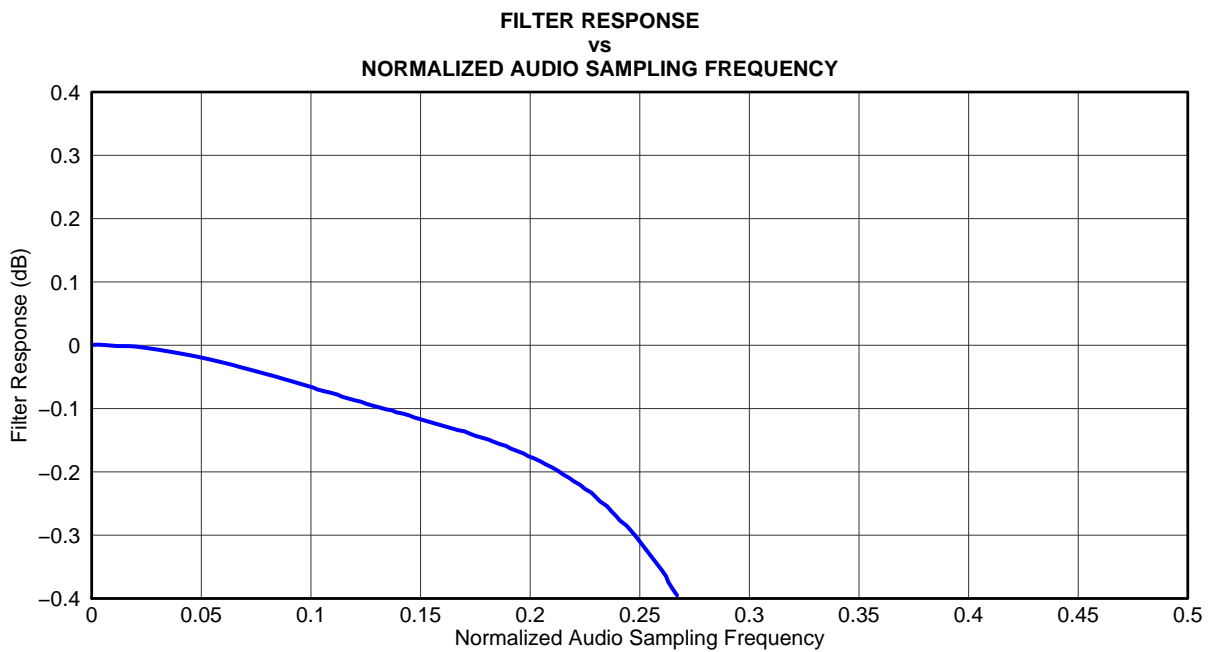

Figure 3-24. DAC Digital Filter Ripple 2: USB Mode and Normal Modes

G016

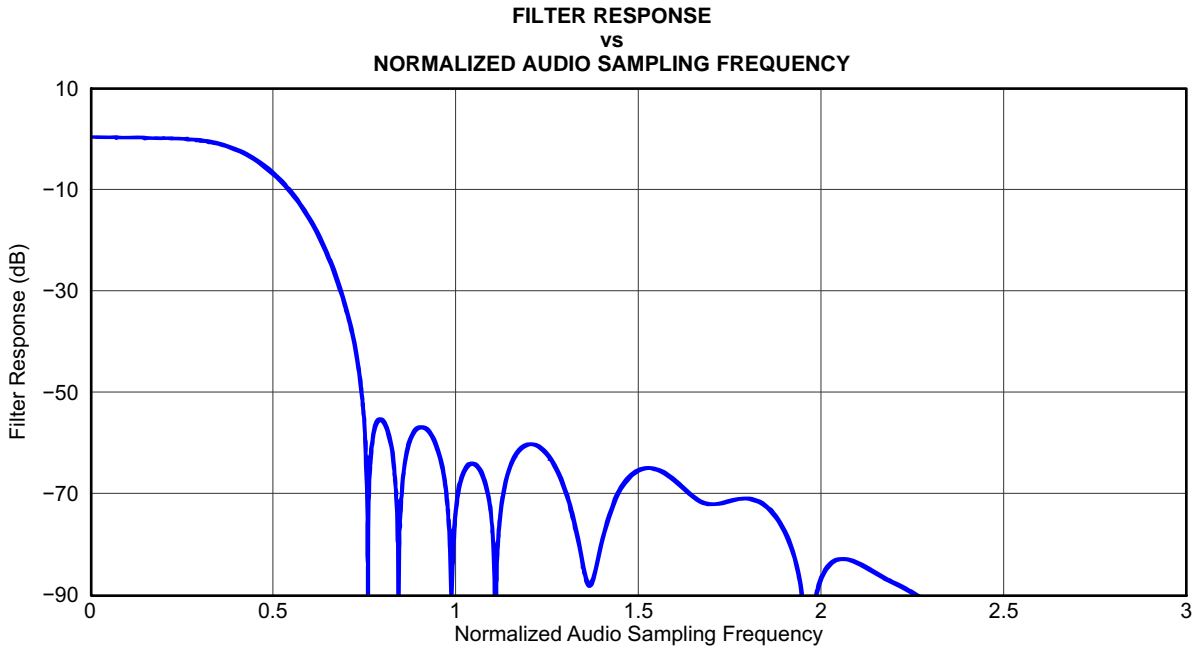

Figure 3-25. DAC Digital Filter Response 3: USB Mode Only

G017

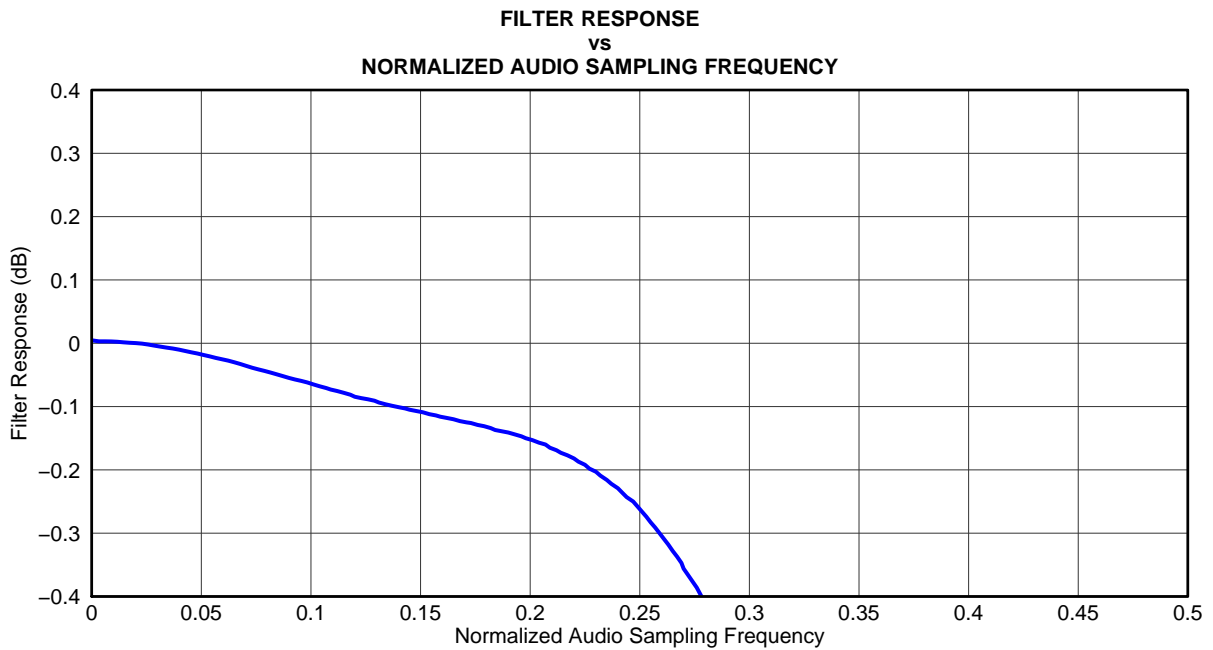

Figure 3-26. DAC Digital Filter Ripple 3: USB Mode Only

G018

The delay between the converter is a function of the sample rate. The group delays for the AIC23B are shown in the following table. Each delay is one LR clock (1/sample rate).

Table 3-13. Group Delays

FILTER	GROUP DELAY
DAC type 0	11
DAC type 1	18
DAC type 2	5
DAC type 3	5
ADC type 0	12
ADC type 1	20
ADC type 2	3
ADC type 3	6

Revision History

NOTE: Page numbers for previous revisions may differ from page numbers in the current version.

Changes from Revision B (June 2008) to Revision C	Page
<ul style="list-style-type: none">Added sentences after: The TLV320AIC23B-Q1 has the following set of registers, which are used to program the modes of operation, in the Register Map section.	15

PACKAGING INFORMATION

Orderable Device	Status (1)	Package Type	Package Drawing	Pins	Package Qty	Eco Plan (2)	Lead/Ball Finish	MSL Peak Temp (3)	Op Temp (°C)	Top-Side Markings (4)	Samples
6PAIC23BIPWRG4Q1	ACTIVE	TSSOP	PW	28	2000	Green (RoHS & no Sb/Br)	CU NIPDAU	Level-1-260C-UNLIM	-40 to 85	AIC23BIQ1	Samples
TLV320AIC23BIPWRQ1	ACTIVE	TSSOP	PW	28	2000	Green (RoHS & no Sb/Br)	CU NIPDAU	Level-1-260C-UNLIM	-40 to 85	AIC23BIQ1	Samples

(1) The marketing status values are defined as follows:

ACTIVE: Product device recommended for new designs.

LIFEBUY: TI has announced that the device will be discontinued, and a lifetime-buy period is in effect.

NRND: Not recommended for new designs. Device is in production to support existing customers, but TI does not recommend using this part in a new design.

PREVIEW: Device has been announced but is not in production. Samples may or may not be available.

OBSOLETE: TI has discontinued the production of the device.

(2) Eco Plan - The planned eco-friendly classification: Pb-Free (RoHS), Pb-Free (RoHS Exempt), or Green (RoHS & no Sb/Br) - please check <http://www.ti.com/productcontent> for the latest availability information and additional product content details.

TBD: The Pb-Free/Green conversion plan has not been defined.

Pb-Free (RoHS): TI's terms "Lead-Free" or "Pb-Free" mean semiconductor products that are compatible with the current RoHS requirements for all 6 substances, including the requirement that lead not exceed 0.1% by weight in homogeneous materials. Where designed to be soldered at high temperatures, TI Pb-Free products are suitable for use in specified lead-free processes.

Pb-Free (RoHS Exempt): This component has a RoHS exemption for either 1) lead-based flip-chip solder bumps used between the die and package, or 2) lead-based die adhesive used between the die and leadframe. The component is otherwise considered Pb-Free (RoHS compatible) as defined above.

Green (RoHS & no Sb/Br): TI defines "Green" to mean Pb-Free (RoHS compatible), and free of Bromine (Br) and Antimony (Sb) based flame retardants (Br or Sb do not exceed 0.1% by weight in homogeneous material)

(3) MSL, Peak Temp. -- The Moisture Sensitivity Level rating according to the JEDEC industry standard classifications, and peak solder temperature.

(4) Multiple Top-Side Markings will be inside parentheses. Only one Top-Side Marking contained in parentheses and separated by a "~" will appear on a device. If a line is indented then it is a continuation of the previous line and the two combined represent the entire Top-Side Marking for that device.

Important Information and Disclaimer: The information provided on this page represents TI's knowledge and belief as of the date that it is provided. TI bases its knowledge and belief on information provided by third parties, and makes no representation or warranty as to the accuracy of such information. Efforts are underway to better integrate information from third parties. TI has taken and continues to take reasonable steps to provide representative and accurate information but may not have conducted destructive testing or chemical analysis on incoming materials and chemicals. TI and TI suppliers consider certain information to be proprietary, and thus CAS numbers and other limited information may not be available for release.

In no event shall TI's liability arising out of such information exceed the total purchase price of the TI part(s) at issue in this document sold by TI to Customer on an annual basis.

OTHER QUALIFIED VERSIONS OF TLV320AIC23B-Q1 :

- Catalog: [TLV320AIC23B](#)

NOTE: Qualified Version Definitions:

- Catalog - TI's standard catalog product

MECHANICAL DATA

PW (R-PDSO-G28)

PLASTIC SMALL OUTLINE

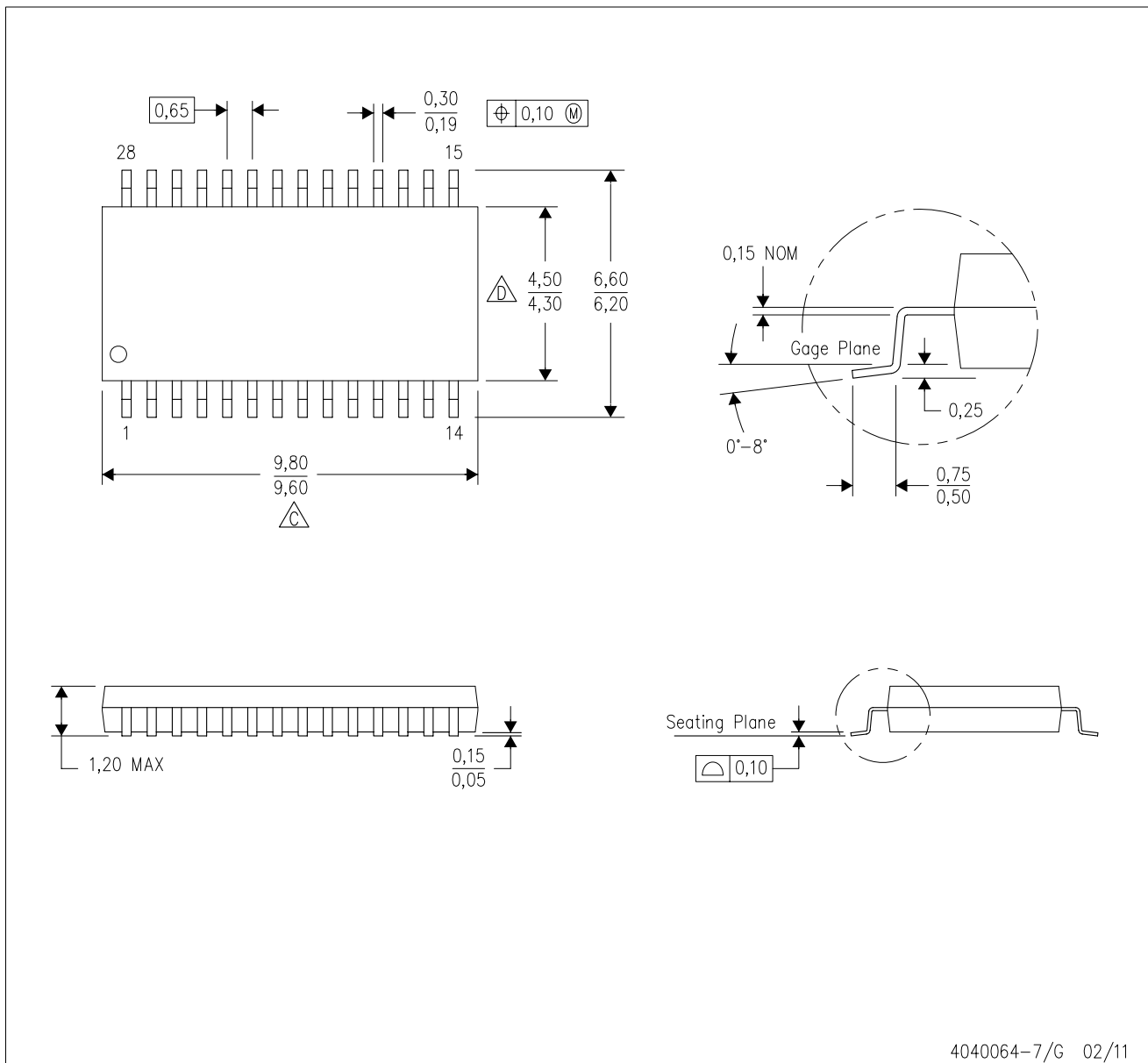

4040064-7/G 02/11

- NOTES:
- A. All linear dimensions are in millimeters. Dimensioning and tolerancing per ASME Y14.5M-1994.
 - B. This drawing is subject to change without notice.
 - C. Body length does not include mold flash, protrusions, or gate burrs. Mold flash, protrusions, or gate burrs shall not exceed 0,15 each side.
 - D. Body width does not include interlead flash. Interlead flash shall not exceed 0,25 each side.
 - E. Falls within JEDEC MO-153

PW (R-PDSO-G28)

PLASTIC SMALL OUTLINE

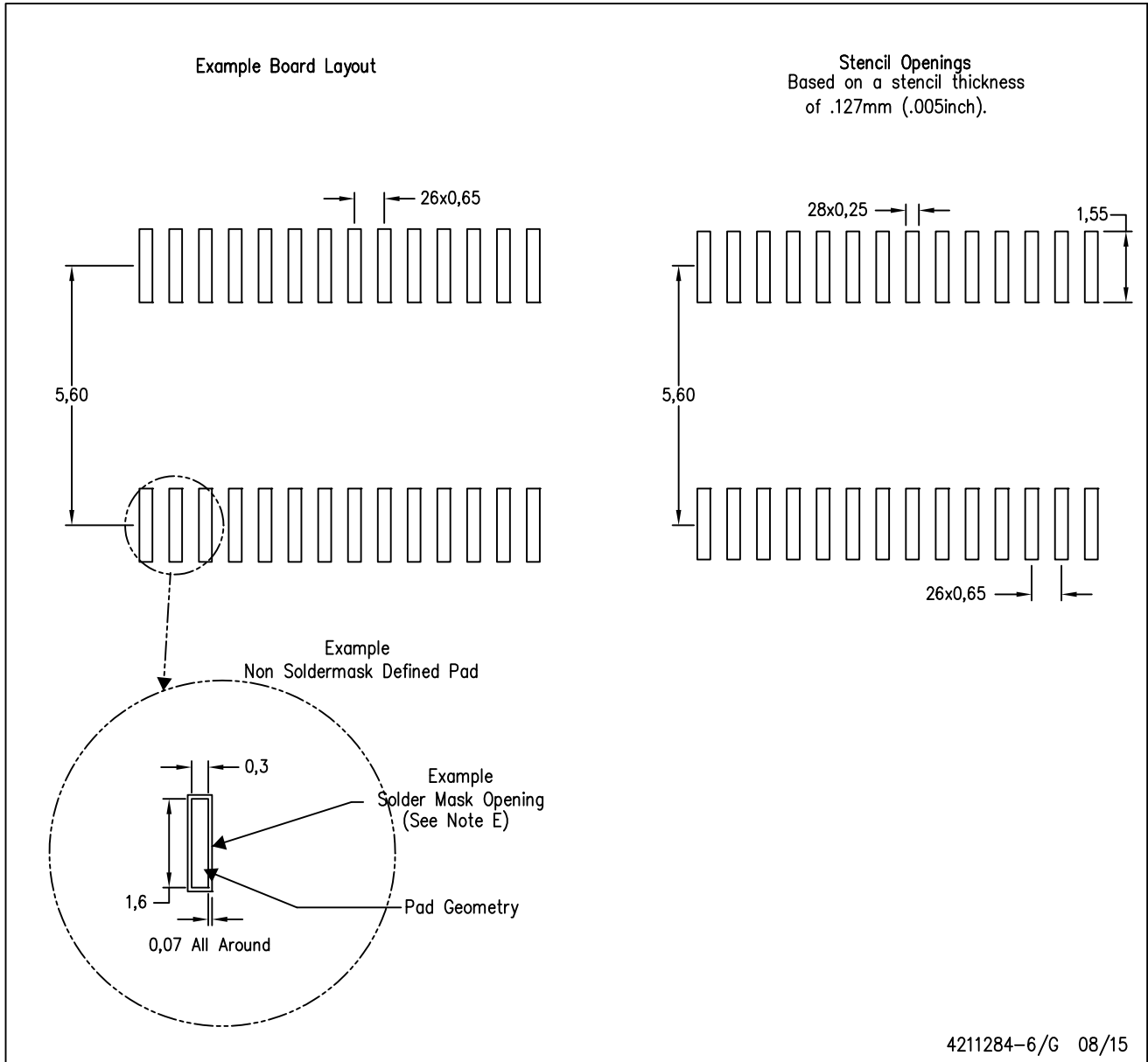

- NOTES:
- All linear dimensions are in millimeters.
 - This drawing is subject to change without notice.
 - Publication IPC-7351 is recommended for alternate design.
 - Laser cutting apertures with trapezoidal walls and also rounding corners will offer better paste release. Customers should contact their board assembly site for stencil design recommendations. Refer to IPC-7525 for other stencil recommendations.
 - Customers should contact their board fabrication site for solder mask tolerances between and around signal pads.

IMPORTANT NOTICE AND DISCLAIMER

TI PROVIDES TECHNICAL AND RELIABILITY DATA (INCLUDING DATASHEETS), DESIGN RESOURCES (INCLUDING REFERENCE DESIGNS), APPLICATION OR OTHER DESIGN ADVICE, WEB TOOLS, SAFETY INFORMATION, AND OTHER RESOURCES "AS IS" AND WITH ALL FAULTS, AND DISCLAIMS ALL WARRANTIES, EXPRESS AND IMPLIED, INCLUDING WITHOUT LIMITATION ANY IMPLIED WARRANTIES OF MERCHANTABILITY, FITNESS FOR A PARTICULAR PURPOSE OR NON-INFRINGEMENT OF THIRD PARTY INTELLECTUAL PROPERTY RIGHTS.

These resources are intended for skilled developers designing with TI products. You are solely responsible for (1) selecting the appropriate TI products for your application, (2) designing, validating and testing your application, and (3) ensuring your application meets applicable standards, and any other safety, security, or other requirements. These resources are subject to change without notice. TI grants you permission to use these resources only for development of an application that uses the TI products described in the resource. Other reproduction and display of these resources is prohibited. No license is granted to any other TI intellectual property right or to any third party intellectual property right. TI disclaims responsibility for, and you will fully indemnify TI and its representatives against, any claims, damages, costs, losses, and liabilities arising out of your use of these resources.

TI's products are provided subject to TI's Terms of Sale (www.ti.com/legal/termsofsale.html) or other applicable terms available either on ti.com or provided in conjunction with such TI products. TI's provision of these resources does not expand or otherwise alter TI's applicable warranties or warranty disclaimers for TI products.

Mailing Address: Texas Instruments, Post Office Box 655303, Dallas, Texas 75265
Copyright © 2019, Texas Instruments Incorporated

Looking for pricing, stock, or lifecycle information?

Click below to explore more details on WIN SOURCE:

 [View 6PAIC23BIPWRG4Q1](#) on WIN SOURCE

 [Texas Instruments](#) Information

Optimize Your Supply Chain with WIN SOURCE Solutions

-  Global Sourcing Solution
-  Obsolete Management
-  Cost Control Management
-  Shortage Management
-  Alternative Solution
-  Excess Inventory Management