



Dec.2008

6N138, 6N139 Single Channel, High Speed Optocouplers

Description

These high gain series couplers use a light emitter diode and an integrated high gain photo detector to provide extremely high current transfer ratio between input and output. Separate pins for the photodiode and output stage result in TTL compatible saturation voltage and high speed operation. Where desired the V_{cc} and V_o terminals may be tied together to achieve conventional photo darlington operation. A base access terminal allows a gain bandwidth adjustment to be made.

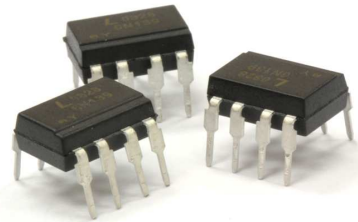

Functional Diagram

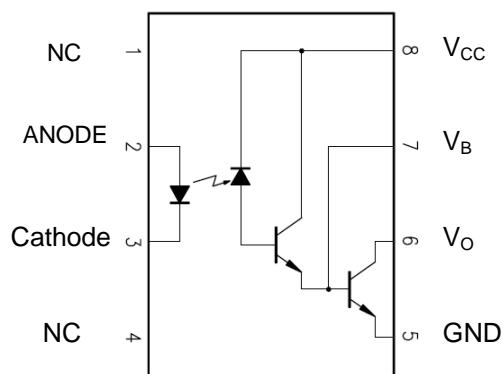

6N138 / 6N139

Truth Table (Positive Logic)

LED	OUT
ON	L
OFF	H

A 0.1 μ F bypass Capacitor must be connected between Pin8 and Pin5

Features

- High current transfer ratio – 2000% typical.
- Low input current requirements – 0.5mA
- High output current – 60mA
- CTR guarantee – 0~70°C.
- Instantaneous common mode rejection 10KV/ μ sec
- TTL compatible output – 0.1V V_{OL} typical
- UL, CSA approved.

APPLICATIONS

- Digital logic ground isolation
- Low input current line receiver
- Telephone ring detector
- EIA-RS-232C line receiver
- Current loop receiver
- High common mode noise line receiver

Ordering Information

Part	Option	Minimum CMR		CTR	Remarks
		dV/dt (V/ μ s)	V _{CM} (V)		
6N138	M	1,000	10	400	Single Channel, DIP-8
	S				Single Channel, Wide Lead Spacing
6N139	M	1,000	10	300	Single Channel, SMD-8
	S				Single Channel, DIP-8
					Single Channel, Wide Lead Spacing
					Single Channel, SMD-8

OUTLINE DIMENSIONS

8-pin DIP Package (6N138 / 6N139)

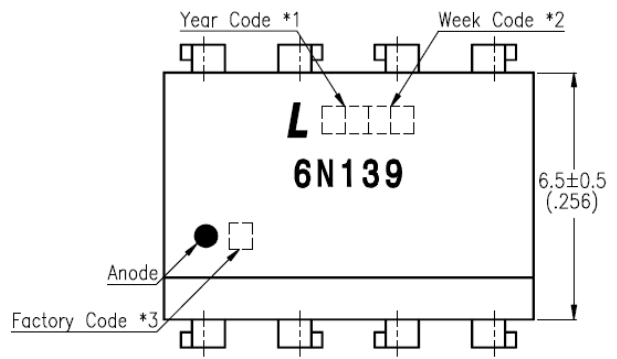
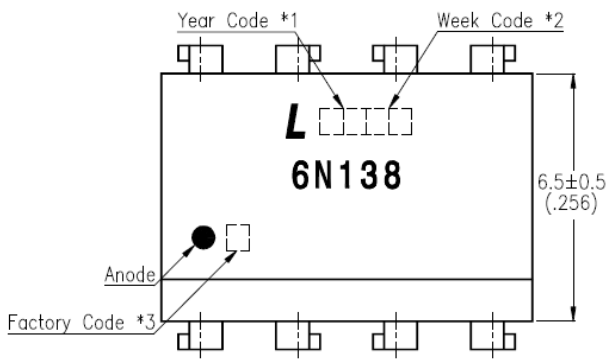

- *1. Year date code.
 - *2. 2-digit work week.
 - *3. Factory identification mark
(Z : Taiwan, Y : Thailand).
- Dimensions are in Millimeters and (Inches).

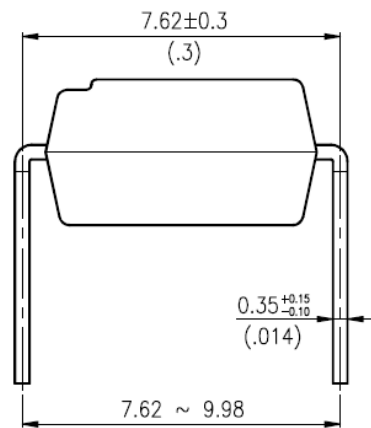
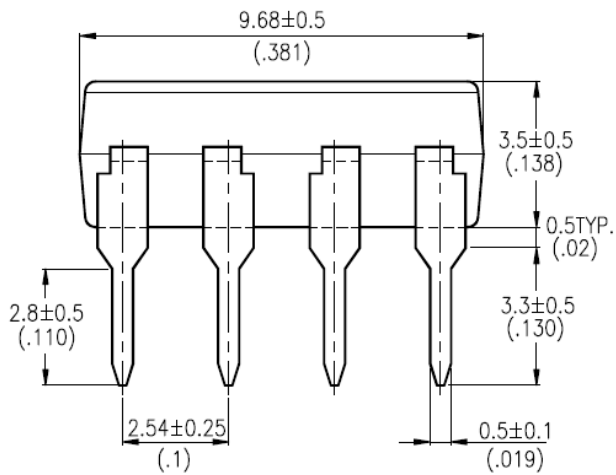

OUTLINE DIMENSIONS

8-pin DIP Wide Lead Spacing Package (6N138M / 6N139M)

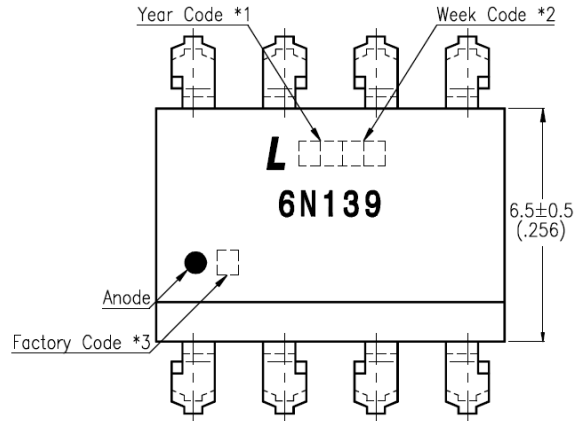
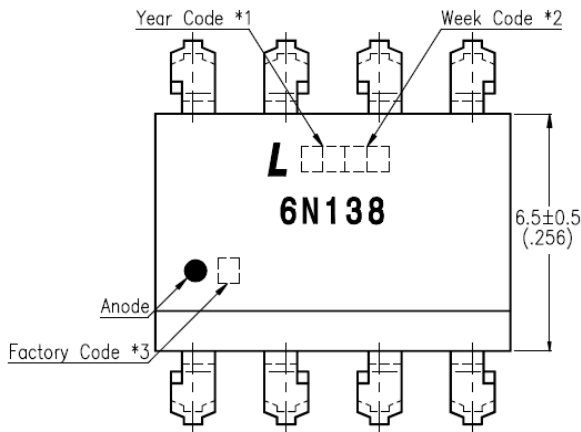

- *1. Year date code.
- *2. 2-digit work week.
- *3. Factory identification mark
(Z : Taiwan, Y : Thailand).

Dimensions are in Millimeters and (Inches).

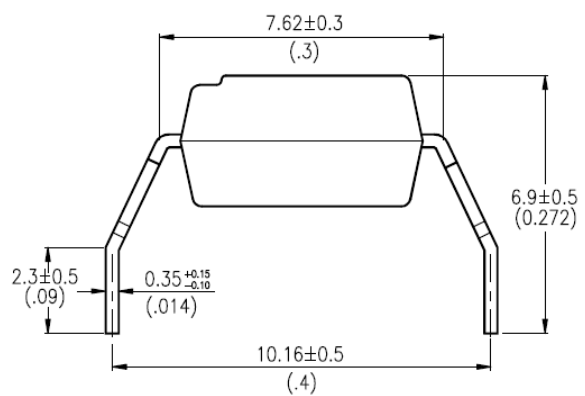
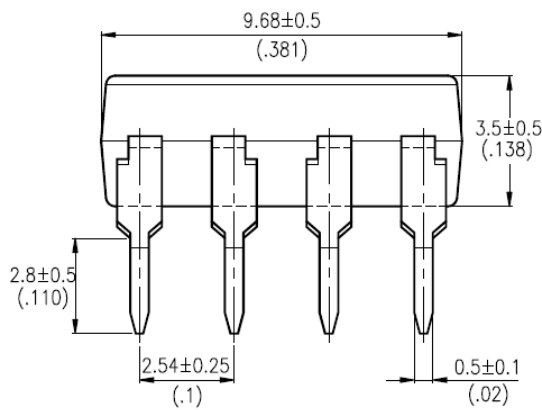

OUTLINE DIMENSIONS

8-pin DIP Surface Mount Package (6N138S / 6N139S)

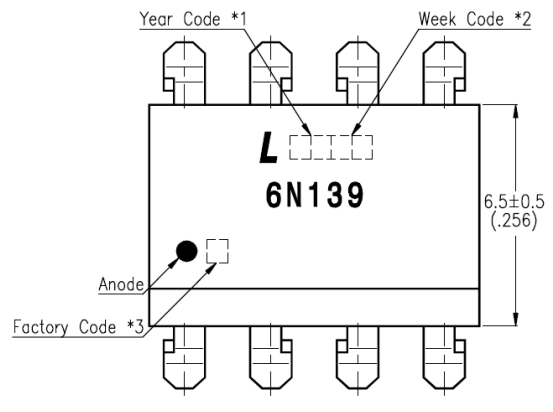
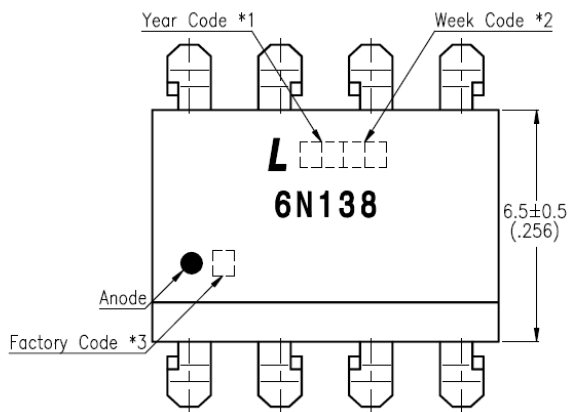

- *1. Year date code.
 - *2. 2-digit work week.
 - *3. Factory identification mark
(Z : Taiwan, Y : Thailand).
- Dimensions are in Millimeters and (Inches).

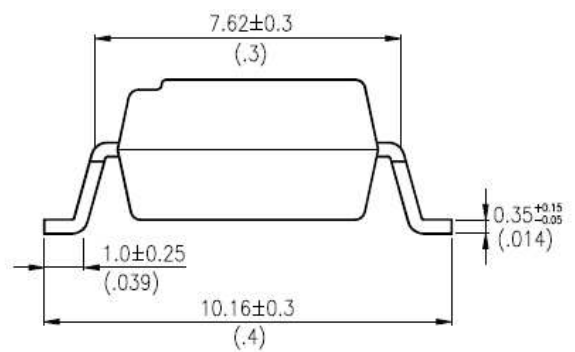
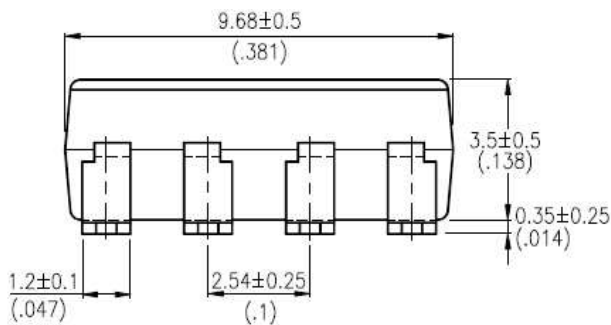

TAPING DIMENSIONS

6N138S/6N139S-TA

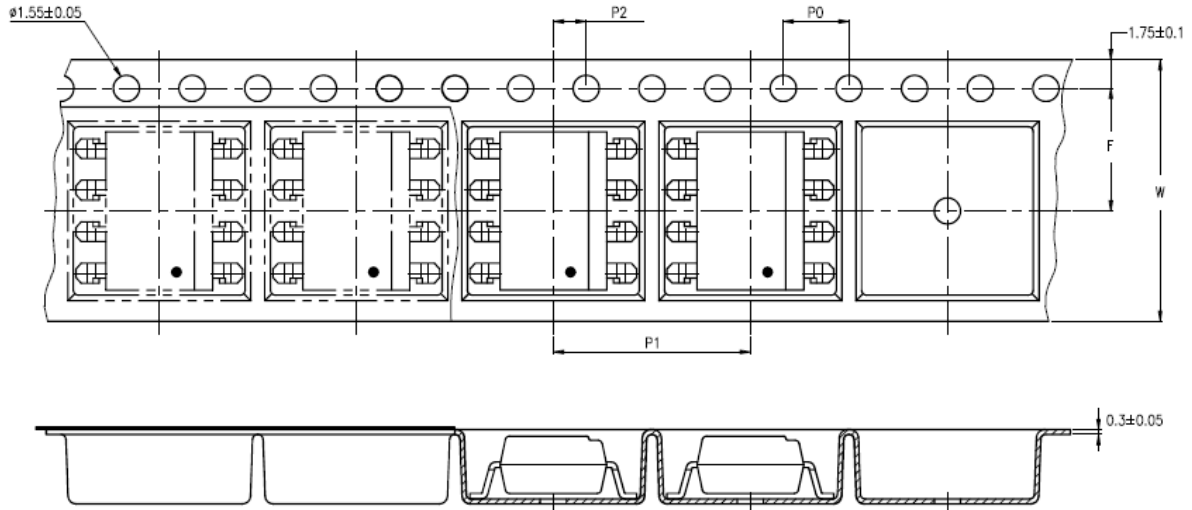

6N138S/6N139S-TA1

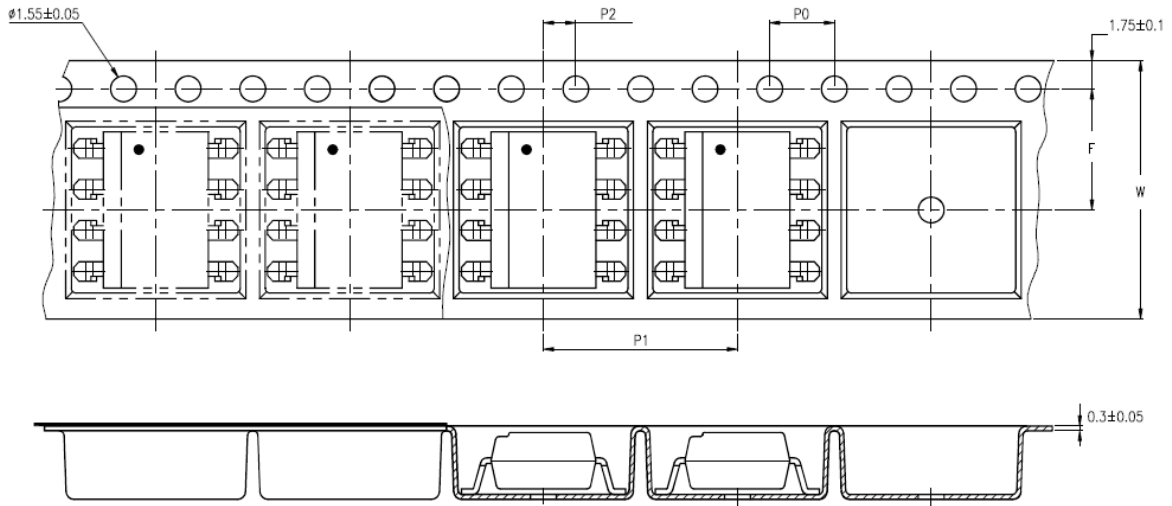

Description	Symbol	Dimensions in millimeters (inches)
Tape wide	W	16 ± 0.3 (.63)
Pitch of sprocket holes	P0	4 ± 0.1 (.15)
Distance of compartment	F P2	7.5 ± 0.1 (.295) 2 ± 0.1 (.079)
Distance of compartment to compartment	P1	12 ± 0.1 (.472)

Recommended Lead Free Reflow Profile

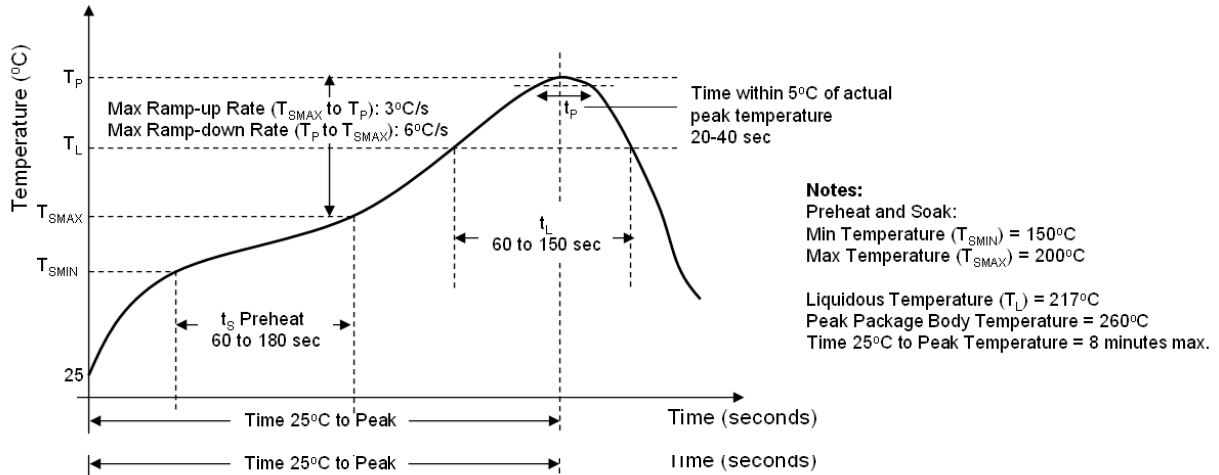

Absolute Maximum Ratings*1

Parameter	Symbol	Device	Min	TYP	Max	Units
Storage Temperature	T_{ST}	6N138 6N139	-55		125	°C
Operating Temperature	T_A		-20		85	°C
Isolation Voltage	V_{ISO}		5000			V_{RMS}
Supply Voltage	V_{CC}				15	V
Lead Solder Temperature * 2	T_{SOL}				260	°C
Input						
Average Forward Input Current	I_F	6N138 6N139			20	mA
Reverse Input Voltage	V_R		5			V
Input Power Dissipation	P_I		35			mW
Output						
Average Output Current	I_O	6N138 6N139			50	mA
Supply Voltage, Output Voltage	V_{CC}, V_O	6N138	-0.5		7	V
		6N139	-0.5		18	
Output Collector Power Dissipation	P_O	6N138 6N139			100	mW

1. Ambient temperature = 25°C, unless otherwise specified. Stresses exceeding the absolute maximum ratings can cause permanent damage to the device. Exposure to absolute maximum ratings for long periods of time can adversely affect reliability.

2. 260°C for 10 seconds. Refer to Lead Free Reflow Profile.

Electrical Specifications

Parameters	Test Condition	Symbol	Device	Min	Typ	Max	Units
Input							
Input Forward Voltage	$I_F=1.6\text{mA}$, $T_A=25^\circ\text{C}$	V_F	6N138 6N139		1.1	1.7	V
Input Forward Voltage Temperature Coefficient	$I_F=1.6\text{mA}$	$\Delta V_F/\Delta T_A$			-1.9		mV/°C
Input Reverse Voltage	$I_R=10\mu\text{A}$, $T_A=25^\circ\text{C}$	BV_R		5	-	-	V
Input Capacitance	$V_F=0$; $f=1\text{MHz}$	C_{IN}		-	60	-	pF
Detector							
Current transfer ratio	$I_F=1.6\text{mA}$; $V_o=0.4\text{V}$; $V_{CC}=4.5\text{V}$	CTR	6N138	300	1600	2600	%
	$I_F=0.5\text{mA}$; $V_o=0.4\text{V}$; $V_{CC}=4.5\text{V}$		6N139	400	2000	5000	
	$I_F=1.6\text{mA}$; $V_{CC}=0.4\text{V}$; $V_{CC}=4.5\text{V}$			500	1600	2600	
Logic low output voltage	$I_F=1.6\text{mA}$; $V_{CC}=4.5\text{V}$; $I_o=4.8\text{mA}$	V_{OL}	6N138	-	0.1	0.4	V
	$I_F=0.5\text{mA}$; $V_{CC}=4.5\text{V}$; $I_o=2\text{mA}$		6N139	-	0.1	0.4	
	$I_F=1.6\text{mA}$; $V_{CC}=4.5\text{V}$; $I_o=8\text{mA}$			-	0.1	0.4	
	$I_F=5\text{mA}$; $V_{CC}=4.5\text{V}$; $I_o=15\text{mA}$			-	0.1	0.4	
	$I_F=12\text{mA}$; $V_{CC}=4.5\text{V}$; $I_o=24\text{mA}$			-	0.2	0.4	
Logic high output current	$I_F=0\text{mA}$, $V_o=V_{CC}=7\text{V}$ $T_A=25^\circ\text{C}$	I_{OH}	6N138	-	0.05	250	μA
	$I_F=0\text{mA}$, $V_o=V_{CC}=18\text{V}$ $T_A=25^\circ\text{C}$		6N139	-	0.1	100	
Logic low supply current	$I_F=1.6\text{mA}$, $V_o=\text{open}$ ($V_{CC}=18\text{V}$)	I_{ccl}	6N138 6N139	-	0.4	1.5	mA
Logic high supply current	$I_F=0\text{mA}$, $V_o=\text{open}$; $T_A=25^\circ\text{C}$ ($V_{CC}=18\text{V}$)	I_{cch}	6N138 6N139	-	0.01	10	μA

*All Typical at $T_A=25^\circ\text{C}$

SWITCHING SPECIFICATIONS (AC)

$T_A=0\sim 70^{\circ}\text{C}$, $V_{CC}=5\text{V}$, unless otherwise specified.

Parameter	Test Condition	Symbol	Device	Min	Typ	Max	Units
Propagation Delay Time to Low Output Level	$I_F=1.6\text{mA}$; $R_L=2.2\text{k}\Omega$	t_{PHL}	6N138	-	1.6	10	μs
	$I_F=0.5\text{mA}$; $R_L=4.7\text{k}\Omega$		6N139	-	5	25	
	$I_F=12\text{mA}$; $R_L=270\Omega$			-	0.1	1	
Propagation Delay Time to High Output Level	$I_F=1.6\text{mA}$; $R_L=2.2\text{k}\Omega$	t_{PLH}	6N138	-	10	35	μs
	$I_F=0.5\text{mA}$; $R_L=4.7\text{k}\Omega$		6N139	-	18	60	
	$I_F=12\text{mA}$; $R_L=270\Omega$			-	2	7	
Logic High Common Mode Transient Immunity	$I_F=0\text{mA}$; $ V_{CM} =10\text{V}_{p-p}$ $R_L=2.2\text{k}\Omega$	$ CM_H $	6N138	1	10	-	KV/ μs
			6N139				KV/ μs
Logic Low Common Mode Transient Immunity	$I_F=1.6\text{mA}$; $ V_{CM} =10\text{V}_{p-p}$ $R_L=2.2\text{k}\Omega$	$ CM_L $	6N138	1	10	-	KV/ μs
			6N139				KV/ μs

*All Typical at $T_A=25^{\circ}\text{C}$

Isolation Characteristics

Parameter	Test Condition	Symbol	Min	Typ	Max	Units
Input-Output Insulation Leakage Current	45% RH, t = 5s, V _{I-O} = 3kV DC, T _A = 25°C	I _{I-O}			1.0	μA
Withstand Insulation Test Voltage	RH ≤ 50%, t = 1min, T _A = 25°C	V _{ISO}	5000			V _{RMS}
Input-Output Resistance	V _{I-O} = 500V DC	R _{I-O}		10 ¹²		Ω

*All Typical at T_A = 25°C

Notes,

- AC For 1 Minute, R.H. = 40 ~ 60%. Isolation voltage shall be measured using the following method.
 - Short between anode and cathode on the primary side and between collector and emitter on the secondary side.
 - The isolation voltage tester with zero-cross circuit shall be used.
 - The waveform of applied voltage shall be a sine wave.
- For 10 Seconds
- Current Transfer Ratio (CTR) is defined as the ration of output collector current, I_o, to the forward LED input current, I_F, times 100%.
- Pin 7 open.
- Instantaneous common mode rejection voltage "output (1)" represents a common mode voltage variation that can hold the output above (1) level (V_o > 2.0V). Instantaneous common mode rejection voltage "output (0)" represents a common mode voltage variation that can hold the output above (0) level (V_o < 0.8V).
- Device considered a two terminal device. Pins 1, 2, 3 and 4 shorted together and Pins 5, 6, 7 and 8 shorted together.

Switching Time Test Circuit

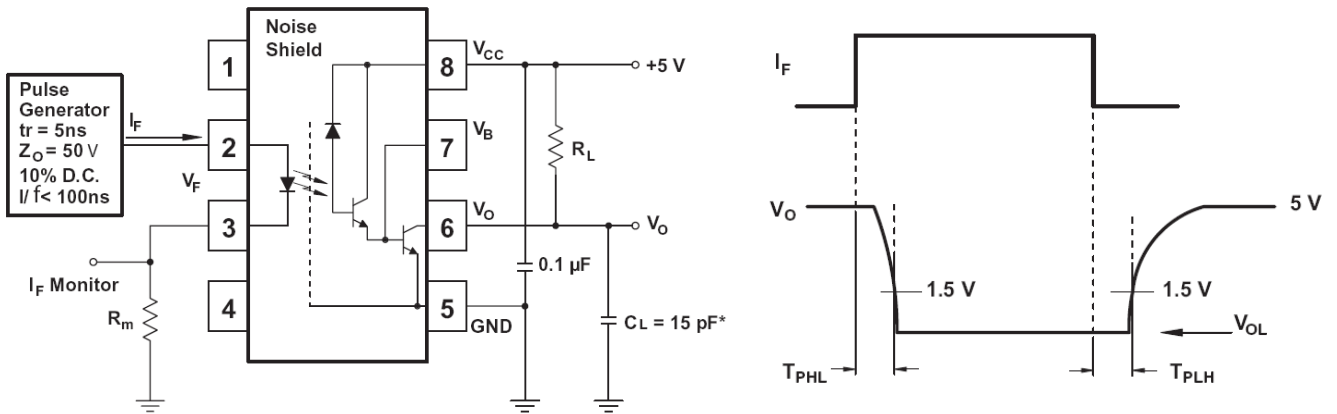

Figure 1: Single Channel Test Circuit for t_{PHL} and t_{PLH}

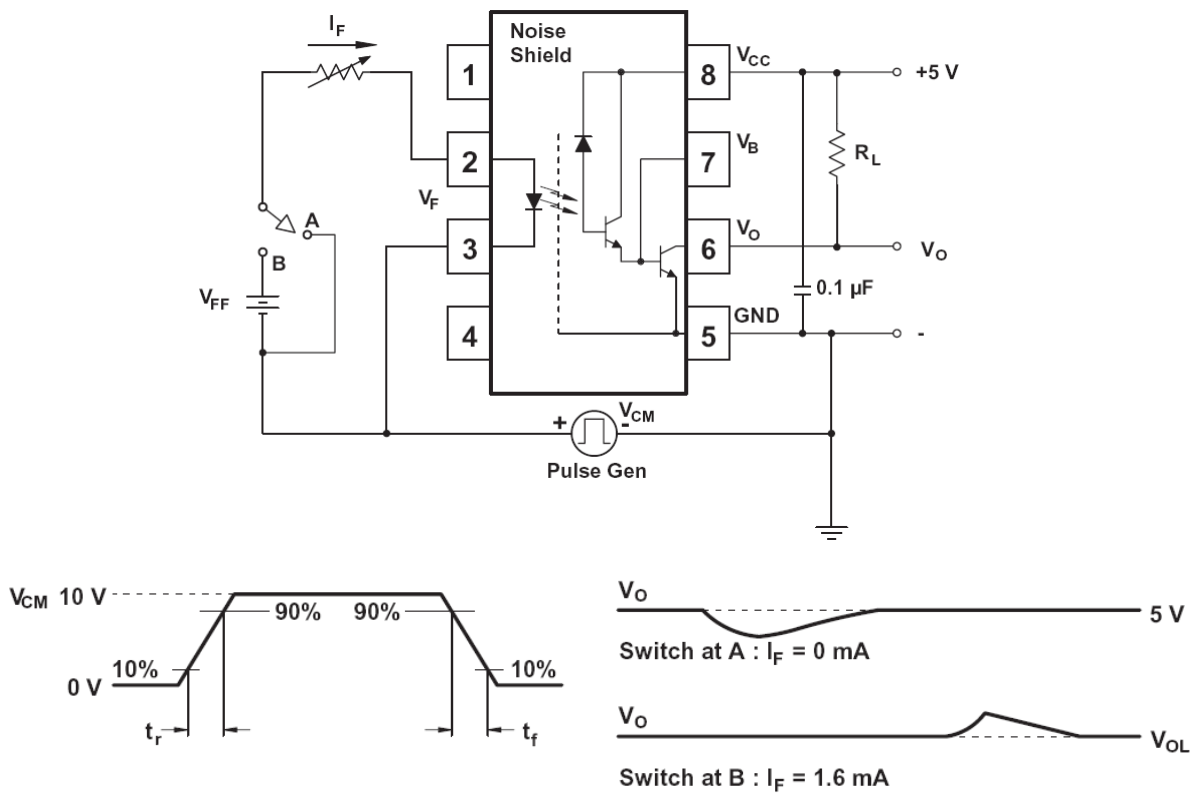

Figure 2: Single Channel Test Circuit for Common Mode Transient Immunity

Characteristics Curves

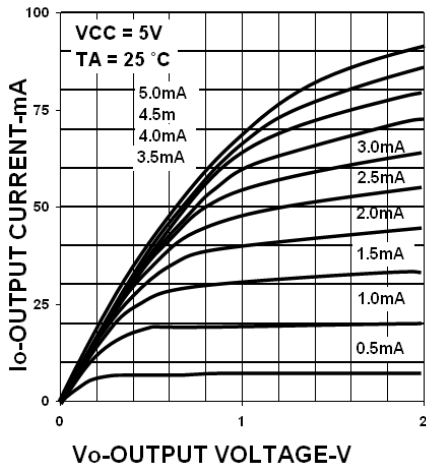

Figure 3: DC transfer characteristics

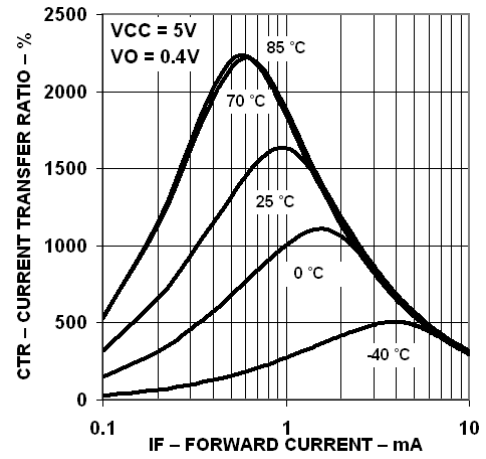

Figure 4: current transfer ratio vs. forward current

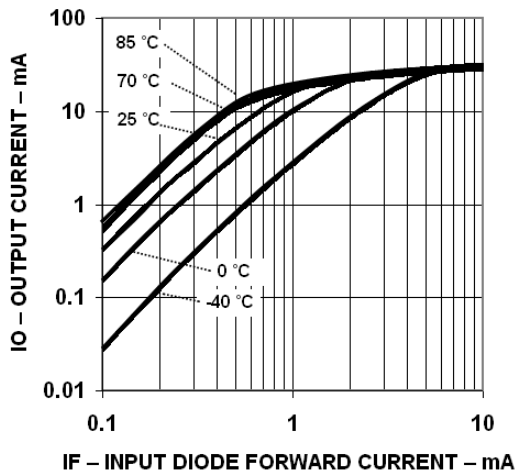

Figure 5: output current vs. input diode forward current

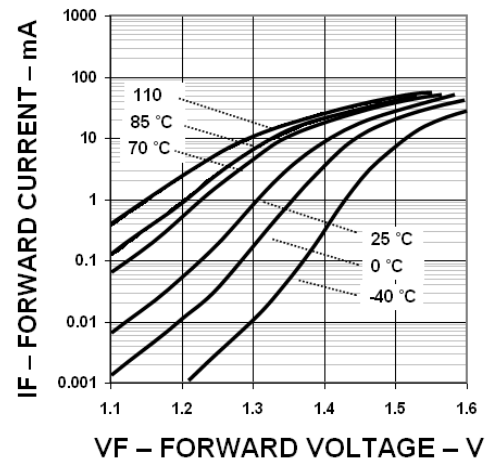

Figure 6: Input diode forward current vs. forward voltage

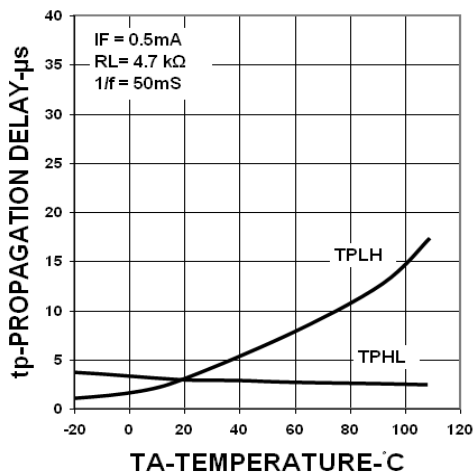

Figure 7: 6N139 propagation delay vs. temperature

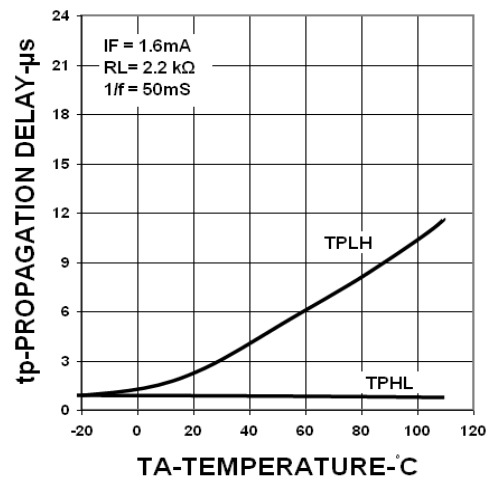

Figure 8: 6N138 propagation delay vs. temperature

Characteristics Curves

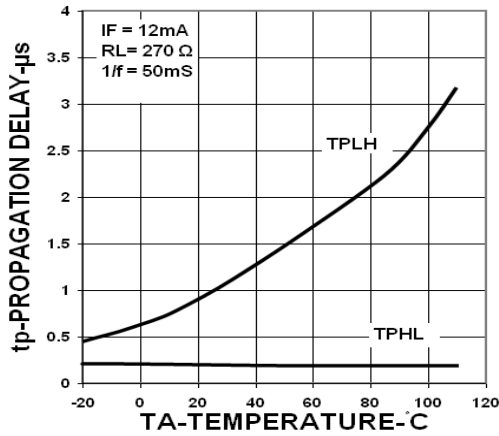

Figure 9: 6N139 propagation delay vs. temperature

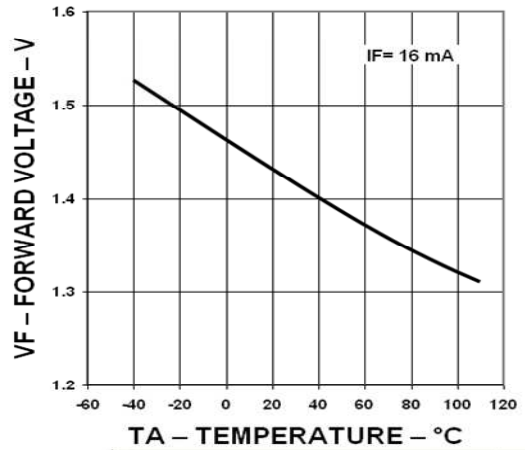

Figure 10: Forward voltage vs. temperature

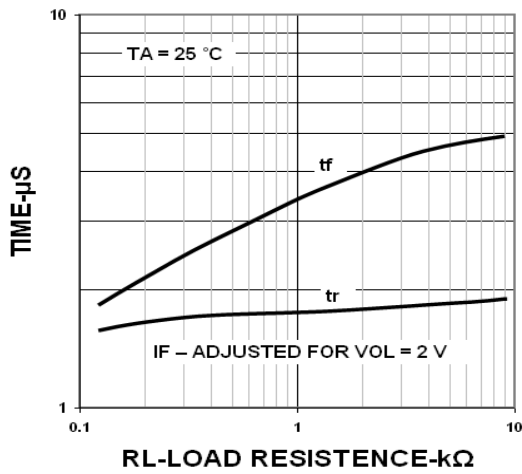

Figure 11: Non-saturated rise and fall time vs. load resistance

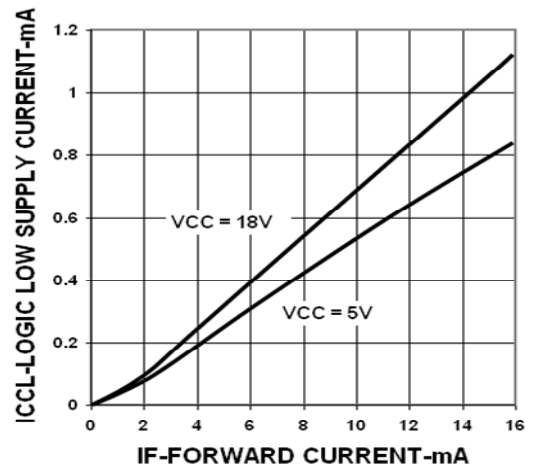

Figure 12: Logic low supply current vs. forward current

LITEON LITE-ON TECHNOLOGY CORPORATION

Property of Lite-on Only

Notes:

Specifications of the products displayed herein are subject to change without notice.

The products shown in this publication are designed for the general use in electronic applications such as office automation equipment, communications devices, audio/visual equipment, electrical instrumentation and application. For equipment/devices where high reliability or safety is required, such as space applications, nuclear power control equipment, medical equipment, etc, please contact our sales representatives.

Looking for pricing, stock, or lifecycle information?

Click below to explore more details on WIN SOURCE:

- [View 6N139M on WIN SOURCE](#)
- [Lite-On Inc. Information](#)

Optimize Your Supply Chain with WIN SOURCE Solutions

- ✓ Global Sourcing Solution
- ✓ Obsolete Management
- ✓ Cost Control Management
- ✓ Shortage Management
- ✓ Alternative Solution
- ✓ Excess Inventory Management