

# **S1R72U16**

## **Data Sheet**

## NOTICE

---

No part of this material may be reproduced or duplicated in any form or by any means without the written permission of Seiko Epson. Seiko Epson reserves the right to make changes to this material without notice. Seiko Epson does not assume any liability of any kind arising out of any inaccuracies contained in this material or due to its application or use in any product or circuit and, further, there is no representation that this material is applicable to products requiring high level reliability, such as, medical products. Moreover, no license to any intellectual property rights is granted by implication or otherwise, and there is no representation or warranty that anything made in accordance with this material will be free from any patent or copyright infringement of a third party. This material or portions thereof may contain technology or the subject relating to strategic products under the control of the Foreign Exchange and Foreign Trade Law of Japan and may require an export license from the Ministry of Economy, Trade and Industry or other approval from another government agency.

All other product names mentioned herein are trademarks and/or registered trademarks of their respective companies.

## Scope

This document applies to the S1R72U16 IDE device - USB 2.0 host bridge LSI.

### **Notice**

Before using the S1R72U16, carefully read the sections “Special use case for S1R72U16” and “S1R72U16 Errata.”

# Table of Contents

<b>1. Overview</b> .....	<b>1</b>
<b>2. Features</b> .....	<b>2</b>
<b>3. Block Diagram</b> .....	<b>4</b>
<b>4. Functions</b> .....	<b>5</b>
4.1 Main CPU I/F .....	5
4.1.1 IDE Device Controller .....	5
4.1.2 CPUIF.....	5
4.2 USB Host.....	5
4.3 GPI .....	5
4.4 GPO .....	5
4.5 SIO .....	6
4.6 OSC.....	6
<b>5. Pin Layout Diagram</b> .....	<b>7</b>
<b>6. Pin Functions</b> .....	<b>8</b>
6.1 IDE Mode.....	8
6.2 CPU Mode.....	11
<b>7. Register</b> .....	<b>12</b>
7.1 Register Map .....	12
7.1.1 IDE Mode Register Map .....	12
7.1.2 CPU Mode Register Map.....	12
7.2 Registers .....	13
7.2.1 Data Register .....	13
7.2.2 Error Register .....	13
7.2.3 Feature Register.....	13
7.2.4 Sector Count Register .....	13

7.2.5	LBA Low Register .....	13
7.2.6	LBA Mid Register .....	14
7.2.7	LBA High Register .....	14
7.2.8	Device Register .....	14
7.2.9	Status Register .....	14
7.2.10	Command Register .....	14
7.2.11	Alternate Status Register .....	15
7.2.12	Device Control Register .....	15
<b>8.</b>	<b>Electrical Characteristics .....</b>	<b>16</b>
8.1	Absolute Maximum Ratings .....	16
8.2	Recommended Operating Conditions .....	16
8.3	DC Characteristics .....	17
8.3.1	Current Consumption .....	17
8.3.2	Input Characteristics .....	18
8.3.3	Output Characteristics .....	19
8.3.4	Pin Capacitance .....	20
8.4	AC Characteristics .....	21
8.4.1	Reset Timing .....	21
8.4.2	Clock Timing .....	21
8.4.3	USB I/F Timing .....	22
8.4.4	IDE Device I/F Timing .....	22
8.4.5	CPUIF Timing (PIO) .....	23
8.4.6	CPUIF Timing (DMA) .....	24
8.4.7	Serial I/F Timing .....	25
<b>9.</b>	<b>Connection Examples .....</b>	<b>26</b>
<b>10.</b>	<b>External Dimensions Diagram .....</b>	<b>27</b>
10.1	PFBGA8UX81 .....	27

10.2 QFP14-80.....	28
<b>11. Product Codes .....</b>	<b>29</b>

## 1. Overview

The S1R72U16 is an IDE device - USB 2.0 host bridge LSI that supports USB2.0-compliant high-speed mode. The main CPU is capable of controlling USB storage devices connected to this LSI as IDE devices. No USB driver is required. USB devices that can be connected to this LSI are bulk-only transport mass storage class devices (e.g., USB memory) and HUB devices.

## 2. Features

### ■ Easy use/connect (IDE bus connection)

#### Allows USB devices to be controlled as IDE devices

The main CPU is capable of controlling USB storage devices connected to this LSI as IDE devices. This LSI handles connection processing for the USB hub, no USB driver is required at the main CPU. An ATA/ATAPI driver should be installed at the main CPU.

A main CPU with an installed ATA/ATAPI driver is capable of controlling USB storage devices via this LSI.

### ■ Easy use/connect (CPU bus connection)

#### Also permits CPU bus connections (interface voltage: 1.8 V to 3.3 V)

The LSI can also be connected to a memory bus to connect to the main CPU without an IDE bus. An ATA/ATAPI driver should be installed in the main CPU. The registers used to control this LSI are ATA task file registers.

### ■ High-speed transfer

#### Transfer rate 31 MB/s (Seiko Epson figures)

Transfer rates of up to 31 MB/s can be achieved with ATA100 and USB High-Speed connection.

### ■ Embedded Host silicon authentication

#### High-quality USB signal

This LSI includes an Embedded Host function (including authentication software) for silicon authentication. The *S1R72U16 USB 2.0 PCB Design Guide* and *S1R72U16 Embedded Host Compliance Manual* are also provided to help the user obtain USB logo certification.

### ■ Product (system) development support functions

#### History display

LSI internal processing history can be displayed using the serial (asynchronous) interface. The *S1R72U16 Development Support Manual* provides detailed information on this function. This function and the manual provide support for product (system) development.

### ■ Manuals and tools

#### Development manuals and tools (bridge board)

The following manuals are provided in addition to this data sheet:

- *S1R72U16 Technical Manual*
- *S1R72U16 Application Note*
- *S1R72U16 Development Support Manual*
- *S1R72U16 USB 2.0 PCB Design Guide*
- *S1R72U16 Embedded Host Compliance Manual*

- *S1R72U16 Evaluation Board Manual*

An IDE device - USB 2.0 host bridge board is also provided for system evaluations in the early stages of product (system) development. \*

- \* Please contact your nearest Seiko Epson sales office to obtain the IDE device - USB 2.0 host bridge board.

3. Block Diagram

3. Block Diagram

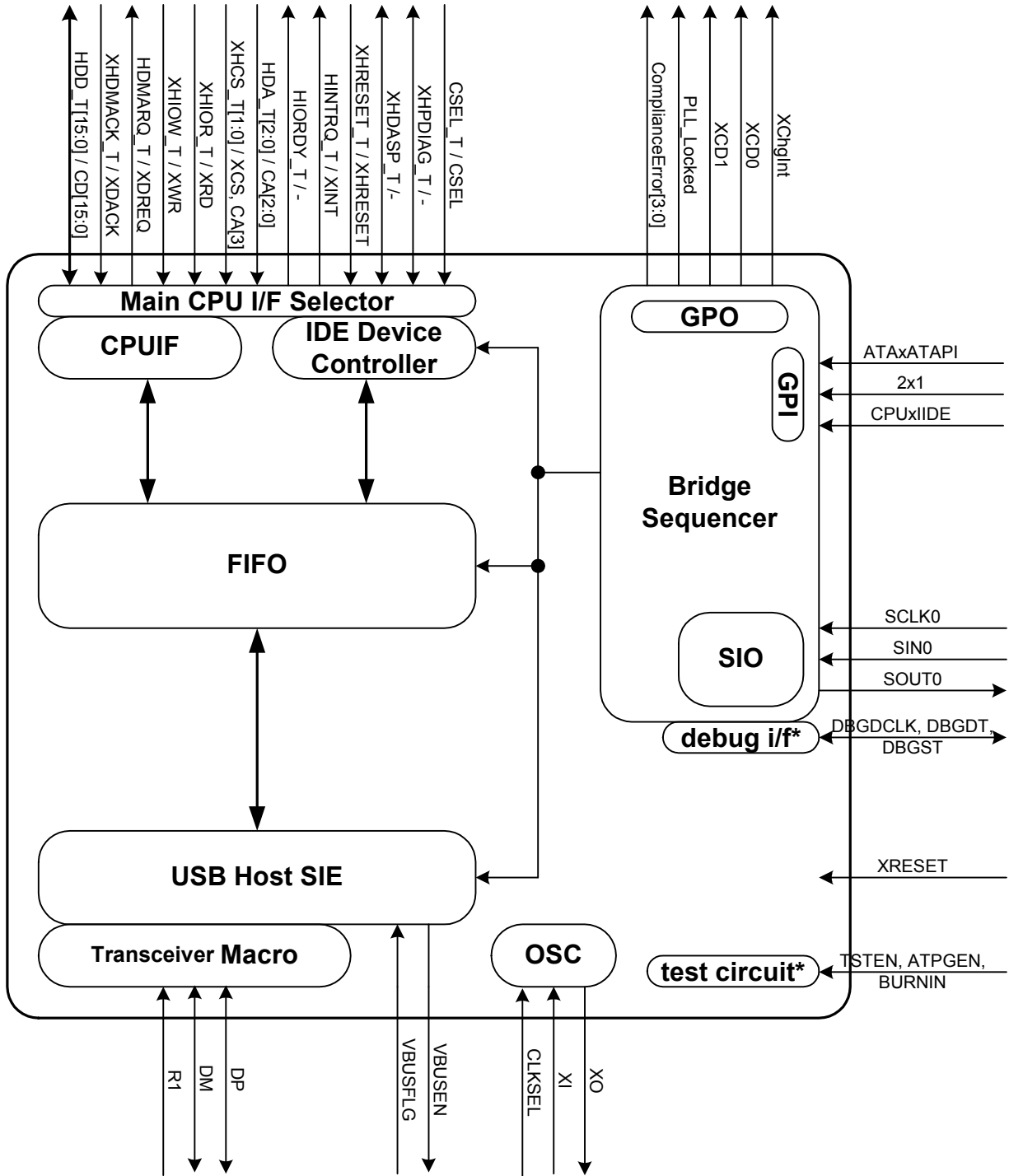

Figure 3.1 Block diagram

\* Fix the debug I/F and test circuit pins strictly as described in “6. Pin Functions”. They are not intended for use by users.

---

## 4. Functions

### 4.1 Main CPU I/F

This LSI can be used as either of the following connections to the main CPU.

- IDE bus connection (interface voltage: 3.3 V)
- CPU bus connection (interface voltage: 1.8 V to 3.3 V)

Bus connection is selected by using the mode setting pin CPUxIDE (PORT02).

#### 4.1.1 IDE Device Controller

This block operates when IDE bus connection is selected. It supports ATA/ATAPI-6.

- PIO transfer modes 0 to 4
- Multi Word DMA transfer modes 0 to 2
- Ultra DMA transfer modes 0 to 5

#### 4.1.2 CPUIF

This block operates when CPU bus connection is selected. The registers used to control this LSI are ATA task file registers. It supports PIO and DMA (\*) transfer.

- \* For DMA transfer, the main CPU must provide a DMA master function that complies with the DMA specifications of this LSI.

### 4.2 USB Host

The USB host function complies with the USB 2.0 (Universal Serial Bus Specification Revision 2.0) standards. It supports HS (480 Mbps) and FS (12 Mbps) speed modes. USB host function is controlled by the Bridge Sequencer block inside the LSI. USB devices that can be connected to this LSI are bulk-only transport mass storage class devices (e.g., USB memory) and HUB devices.

### 4.3 GPI

These are the mode setting pins for selecting the command system, number of connected devices, and interface to the main CPU.

For detailed information, see the *S1R72U16 Technical Manual*.

### 4.4 GPO

These pins are used to issue notification of USB storage device connections, internal PLL operation status, and NSF (No Silent Failure).

For detailed information, see the *S1R72U16 Technical Manual*.

## 4. Functions

---

### 4.5 SIO

This block is used to display the product (system) development support function history.

For detailed information, see the *S1R72U16 Development Support Manual*.

### 4.6 OSC

This oscillator circuit supports a 12 MHz/24 MHz crystal oscillator. The 12 MHz or 24 MHz clock is selected using the CLKSEL pin.



## 6. Pin Functions

### 6. Pin Functions

#### 6.1 IDE Mode

GENERAL (IOVDD system)					
BGA	QFP	Name	I/O	RESET	Details
G4	24	XRESET	IN	-	Reset signal
C3	77	CLKSEL	IN		XI clock input selection 1: 24MHz 0: 12MHz

OSC (LVDD system)					
BGA	QFP	Name	I/O	RESET	Details
A4	74	XI	IN	-	Internal oscillator circuit input 12MHz/24MHz
A3	75	XO	OUT	-	Internal oscillator circuit output

TEST (LVDD system)					
BGA	QFP	Name	I/O	RESET	Details
A1	80	TSTEN	IN(PD)	-	Test pin (*)
A2	79	ATPGEN	IN(PD)	-	Test pin (*)
D2	78	BURNIN	IN(PD)	-	Test pin (*)

PD: Using pull-down I/O

\* The LSI features internal pull-down, but low fixing is recommended on the circuit board.

USB					
BGA	QFP	Name	I/O	RESET	Details
C1	3	R1	IN	-	Reference voltage setting pin Connect 6.2 k $\Omega$ $\pm$ 1% resistor between VSS.
F1	8	DP	BI	Hi-Z	USB data line Data+
E1	6	DM	BI	Hi-Z	USB data line Data-
F3	15	VBUSFLG	IN(PU)	-	USB power switch fault detection signal 1: Normal, 0: Error CMOS Schmitt input
G3	16	VBUSEN	OUT	Low	USB power switch control signal

PU: Using pull-up I/O

IDE device I/F (IOVDD system)					
BGA	QFP	Name	I/O	RESET	Details
D8	54	HDA2_T	IN	-	IDE register address
D6	52	HDA1_T	IN	-	
D5	51	HDA0_T	IN	-	
E6	50	XHCS1_T	IN	-	Control register access chip selection
E7	49	XHCS0_T	IN	-	Command block register access chip selection
J6	33	XHIOR_T	IN	-	IDE read strobe
G5	31	XHIOW_T	IN	-	IDE write strobe
H5	30	HDMARQ_T	OUT	Low	DMA transfer request
J5	29	XHDMACK_T	IN	-	DMA transfer acknowledge
H6	32	HIORDY_T	OUT (PU)	Hi-z	IDE register ready signal (*)
F5	28	HINTRQ_T	OUT	Low	IDE interrupt request
E9	48	XHRESET_T	IN	-	IDE bus reset
E8	47	XHDASP_T	BI(PU)	Hi-z	Drive enable/slave drive present (*)
F7	46	XHPDIAG_T	BI(PU)	Hi-z	<b>Diagnosis sequence end signal (*)</b>
F9	45	CSEL_T	IN	-	<b>Drive selection</b>
D7	55	HDD15_T	BI	Hi-Z	IDE data bus
C9	56	HDD14_T	BI	Hi-Z	
C8	57	HDD13_T	BI	Hi-Z	
C7	58	HDD12_T	BI	Hi-Z	
B8	59	HDD11_T	BI	Hi-Z	
A8	61	HDD10_T	BI	Hi-Z	
B7	62	HDD9_T	BI	Hi-Z	
A7	63	HDD8_T	BI	Hi-Z	
C6	64	HDD7_T	BI	Hi-Z	
B6	65	HDD6_T	BI	Hi-Z	
C5	67	HDD5_T	BI	Hi-Z	
B5	68	HDD4_T	BI	Hi-Z	
A5	69	HDD3_T	BI	Hi-Z	
D4	70	HDD2_T	BI	Hi-Z	
C4	71	HDD1_T	BI	Hi-Z	
B4	72	HDD0_T	BI	Hi-Z	

PU: Using pull-up I/O

\* LSI internal pull-up is disabled in IDE mode.

Serial I/F (HVDD system)					
BGA	QFP	Name	I/O	RESET	Details
J4	23	SCLK0	I(PU)		Not used (*)
H4	20	SIN0	I(PU)	-	Asynchronous serial data in
J3	22	SOUT0	O	High	Asynchronous serial data out

PU: Using pull-up I/O

\* Set to open or pull-up.

## 6. Pin Functions

DEBUG I/F (HVDD system)					
BGA	QFP	Name	I/O	RESET	Details
H1	17	DBGDCLK	O	High	Not used (*1)
H2	18	DBGDT	BI(PU)	-	Not used (*2)
H3	19	DBGST	O	Low	Not used (*1)

PU: Using pull-up I/O

\*1: Set to open or pull-up.

\*2: The LSI features internal pull-up, but an external pull-up of approximately 10 kΩ is recommended.

GPIO (IOVDD system)					
BGA	QFP	Name	I/O	RESET	Details
E4	26	PORT00 (ATAxATAPI)	I	-	Setting pin 1: ATA mode, 0: ATAPI mode
E5	27	PORT01 (2x1)	I	-	Setting pin 1: two-device mode, 0: one-device mode
F4	25	PORT02 (CPUxIDE)	I	-	Setting pin 1: CPU mode, 0: IDE mode
G6	35	PORT10 (XChgInt)	O	-	Storage device connection detection interrupt 1: -, 0: Connection detection
F6	36	PORT11 (XCD0)	O	-	Storage device 0 detection 1: -, 0: Detect
H7	37	PORT12 (XCD1)	O	-	Storage device 1 detection 1: -, 0: Detect
G7	38	PORT13 (PLL_Locked)	O	-	PLL oscillation start 1: Oscillation start, 0: No oscillation
H8	39	PORT14 (ComplianceErr0)	O	-	Unsupported Device 1: Error, 0: -
G8	42	PORT15 (ComplianceErr1)	O	-	Too Many Devices 1: Error, 0: -
G9	43	PORT16 (ComplianceErr2)	O	-	Too Many Hubs 1: Error, 0: -
F8	44	PORT17 (ComplianceErr3)	O	-	VBUS Over Current 1: Error, 0: -

POWER					
BGA	QFP	Name	Voltage	Details	
D1, F2, J2	5, 9, 21	HVDD	3.3V	USB, UART, DEBUG I/F power supply	
A6, H9	41, 66	IOVDD	3.3V to 1.8V	IDE I/F and GPIO power supply	
B1, G1, B3, J8, B9	1, 10, 40, 60, 76	LVDD	1.8V	Internal power supply, TEST power supply, OSC power supply	
B2, C2, E2, G2, D3, E3, J7, D9	2, 4, 7, 11, 14, 34, 53, 73	VSS	0V	GND	

## 6.2 CPU Mode

CPU memory bus I/F (IOVDD system)					
BGA	QFP	Name	I/O	RESET	Details
D8	54	CA2	IN	-	Address
D6	52	CA1	IN	-	
D5	51	CA0	IN	-	
E6	50	XCS	IN	-	Chip selection
E7	49	CA3	IN	-	Address
J6	33	XRD	IN	-	Read strobe
G5	31	XWR	IN	-	Write strobe
H5	30	XDREQ	OUT	High	DMA transfer request
J5	29	XDACK	IN	-	DMA transfer acknowledge
H6	32	-	OUT(PU)	Hi-z	Not used (*)
F5	28	XINT	OUT	High	Interrupt request
E9	48	XHRESET	IN	-	Bus reset
E8	47	-	BI(PU)	Hi-z	Not used (*)
F7	46	-	BI(PU)	Hi-z	Not used (*)
F9	45	CSEL	IN	-	Drive selection
D7	55	CD15	BI	Hi-Z	Data bus
C9	56	CD14	BI	Hi-Z	
C8	57	CD13	BI	Hi-Z	
C7	58	CD12	BI	Hi-Z	
B8	59	CD11	BI	Hi-Z	
A8	61	CD10	BI	Hi-Z	
B7	62	CD9	BI	Hi-Z	
A7	63	CD8	BI	Hi-Z	
C6	64	CD7	BI	Hi-Z	
B6	65	CD6	BI	Hi-Z	
C5	67	CD5	BI	Hi-Z	
B5	68	CD4	BI	Hi-Z	
A5	69	CD3	BI	Hi-Z	
D4	70	CD2	BI	Hi-Z	
C4	71	CD1	BI	Hi-Z	
B4	72	CD0	BI	Hi-Z	

PU: Using pull-up I/O

\* Set to open or pull-up. LSI internal pull-up resistor is enabled in CPU mode.

For detailed information on pins other than those described above, see “6.1 IDE Mode”.

## 7. Register

### 7.1 Register Map

#### 7.1.1 IDE Mode Register Map

Pin					Register	
XHCS1_T	XHCS0_T	HDA2_T	HDA1_T	HDA0_T	Read	Write
H	L	L	L	L	Data (16bit)	
H	L	L	L	H	Error	Feature
H	L	L	H	L	Sector Count	
H	L	L	H	H	LBA Low	
H	L	H	L	L	LBA Mid	
H	L	H	L	H	LBA High	
H	L	H	H	L	Device	
H	L	H	H	H	Status	Command
L	H	L	L	L	none	
L	H	L	L	H	none	
L	H	L	H	L	none	
L	H	L	H	H	none	
L	H	H	L	L	none	
L	H	H	L	H	none	
L	H	H	H	L	Alternate Status	Device Control
L	H	H	H	H	none	

Figure 7.1 IDE mode register map

#### 7.1.2 CPU Mode Register Map

Pin					Register	
XCS	CA3	CA2	CA1	CA0	Read	Write
L	L	L	L	L	Data (16bit)	
L	L	L	L	H	Error	Feature
L	L	L	H	L	Sector Count	
L	L	L	H	H	LBA Low	
L	L	H	L	L	LBA Mid	
L	L	H	L	H	LBA High	
L	L	H	H	L	Device	
L	L	H	H	H	Status	Command
L	H	L	L	L	none	
L	H	L	L	H	none	
L	H	L	H	L	none	
L	H	L	H	H	none	
L	H	H	L	L	none	
L	H	H	L	H	none	
L	H	H	H	L	Alternate Status	Device Control
L	H	H	H	H	none	

Figure 7.2 CPU mode register map

## 7.2 Registers

These are ATA task file registers. For detailed information, see *AT Attachment with Packet Interface – 6 (ATA/ATAPI-6)*.

### 7.2.1 Data Register

This register permits reads/writes. It is used for data transfers. It supports 16-bit access only.

bit15	bit14	Bit13	bit12	bit11	bit10	bit9	bit8
Data[15:8]							

bit7	bit6	bit5	bit4	bit3	bit2	bit1	bit0
Data[7:0]							

### 7.2.2 Error Register

This is a read-only register. The register value is enabled when the Status register ERR bit is “1”. Bit assignments and values vary, depending on the ATA/ATAPI command.

bit7	bit6	bit5	bit4	bit3	bit2	bit1	bit0
#	#	#	#	#	ABRT	#	#

### 7.2.3 Feature Register

This is a write-only register. Writing to this register depends on the ATA/ATAPI command. Bit assignments and values are defined for each command.

bit7	bit6	bit5	bit4	bit3	bit2	bit1	bit0
Features Byte							

### 7.2.4 Sector Count Register

This register permits reads/writes and sets the number of sectors for data transfers.

bit7	bit6	bit5	bit4	bit3	bit2	bit1	bit0
Sector Count Byte							

### 7.2.5 LBA Low Register

This register permits reads/writes and sets LBA [7:0].

bit7	bit6	bit5	bit4	bit3	bit2	bit1	bit0
LBA Low Byte							

## 7. Register

---

### 7.2.6 LBA Mid Register

This register permits reads/writes and sets LBA [15:8].

bit7	bit6	bit5	bit4	bit3	bit2	bit1	bit0
LBA Mid Byte							

### 7.2.7 LBA High Register

This register permits reads/writes and sets LBA [23:16].

bit7	bit6	bit5	bit4	bit3	bit2	bit1	bit0
LBA High Byte							

### 7.2.8 Device Register

This register permits reads/writes. Bit assignments and values vary, depending on the ATA/ATAPI command.

bit7	bit6	bit5	bit4	bit3	bit2	bit1	bit0
Obsolute	#	Obsolute	DEV	#	#	#	#

### 7.2.9 Status Register

This read-only register is updated to indicate status when a command is executed. Reading this register when the HINTRQ\_T signal is asserted cause to nagate the HINTRQ\_T signal.

bit7	bit6	bit5	bit4	bit3	bit2	bit1	bit0
BSY	DRDY	DF	#	DRQ	Obsolute	ChgInt	ERR

#### Bit 1 ChgInt

This bit, unique to this LSI, indicates whether a USB storage device is connected (using the bit dropped as of *AT Attachment with Packet Interface – 6 (ATA/ATAPI-6)*). The XChgInt signal status can be read off inverted. For detailed information, see the *S1R72U16 Technical Manual*.

### 7.2.10 Command Register

This is a write-only register. The register command is executed immediately on being written. Issuing the command (writing to this register) when the HINTRQ\_T signal is asserted cause to nagate the HINTRQ\_T signal.

bit7	bit6	bit5	bit4	bit3	bit2	bit1	bit0
Command Code							

**7.2.11 Alternate Status Register**

This read-only register is the same as the Status Register except when the HINTRQ\_T signal is not altered.

**7.2.12 Device Control Register**

This write-only register is used to reset the HINTRQ\_T signal control and software and to support Big Drive.

bit7	bit6	bit5	bit4	bit3	bit2	bit1	bit0
HOB	#	#	#	#	SRST	nIEN	#

## 8. Electrical Characteristics

### 8.1 Absolute Maximum Ratings

(V<sub>SS</sub>=0V)

Item	Code	Rating	Units
Power supply voltage	HVDD	VSS-0.3 to 4.0	V
	IOVDD	VSS-0.3 to 4.0	V
	LVDD	VSS-0.3 to 2.5	V
Input voltage (*)	HVI	VSS-0.3 to HVDD+0.5	V
	IOVI	VSS-0.3 to IOVDD+0.5	V
	LVI	VSS-0.3 to LVDD+0.5	V
Output voltage (*)	HVO	VSS-0.3 to HVDD+0.5	V
	IOVO	VSS-0.3 to IOVDD+0.5	V
Output current/pin	IOUT	±10	mA
Storage temperature	Tstg	-65 to 150	°C

\* Check the power supply system information in “6. Pin Functions” for the corresponding pins.

### 8.2 Recommended Operating Conditions

Item	Code	MIN	TYP	MAX	Units
Power supply voltage	HVDD	3.00	3.30	3.60	V
	IOVDD (*1)	1.65	1.80 to 3.30	3.60	V
	LVDD	1.65	1.80	1.95	V
Input voltage (*2)	HVI	-0.3	-	HVDD+0.3	V
	IOVI	-0.3	-	IOVDD+0.3	V
	LVI	-0.3	-	LVDD+0.3	V
Ambient temperature	T <sub>a</sub>	-40	25	85	°C

\*1: Use with 3.3 V (typ) in IDE mode.

\*2: Check the power supply system information in “6. Pin Functions” for the corresponding pins.

#### [Precautions for power-on sequence]

Power to the HVDD and IOVDD should be turned on/off with LVDD confirmed. (\*)

- Power-on: LVDD → (HVDD, IOVDD)
- Power-off: (HVDD, IOVDD) → LVDD

\* Reliability issues may arise if LVDD is cut off and HVDD or IOVDD or both are on continuously for 1 second or longer.

### 8.3 DC Characteristics

#### 8.3.1 Current Consumption

Item	Code	Conditions	MIN	TYP	MAX	Units
Power supply current (*)						
Power current	IDDH	HVDD = 3.6V	-	17.0		mA
	IDDCH	IOVDD = 3.6V	-	2.0		mA
	IDDCL	IOVDD = 1.95V	-	1.5		mA
	IDDL	LVDD = 1.95V	-	65.0		mA
Static current						
Power current	IDDS	VIN = HVDD, IOVDD, LVDD or VSS	-	-	70	μA
		HVDD = 3.6V				
		IOVDD = 3.6V				
		LVDD = 1.95V				
Input leak						
Input leak current	IL	HVDD = 3.6V IOVDD = 3.6V LVDD = 1.95V HVIH = HVDD IOVIH = IOVDD LVIH = LVDD	-5	-	5	μA

\* Mean operating current at recommended operating conditions (Ta = 25°C)

## 8. Electrical Characteristics

### 8.3.2 Input Characteristics

Item	Code	Conditions	MIN	TYP	MAX	Units
Input characteristics	Pin:	TSTEN, ATPGEN, BURNIN, XI				
“H” level input voltage	VIH1	LVDD = 1.95V	1.27	-	-	V
“L” level input voltage	VIL1	LVDD = 1.65V	-	-	0.57	V
Input characteristics	Pin:	HDD_T[15:0], HAD_T[2:0], XHCS_T[1:0], XHIOR_T, XHIOW_T, XHDMACK_T, XHRESET_T, XHDASP_T, XHPDIAG_T, CSEL_T				
“H” level input voltage	VIH2	IOVDD = 3.6V IOVDD = 1.95V	2.0 1.27	-	-	V
“L” level input voltage	VIL2	IOVDD = 3.0V IOVDD = 1.65V	-	-	0.8 0.57	V
Input characteristics	Pin:	XRESET, CLKSEL, PORT00, PORT01, PORT02				
“H” level input voltage	VIH3	IOVDD = 3.6V IOVDD = 1.95V	2.2 1.20	-	-	V
“L” level input voltage	VIL3	IOVDD = 3.0V IOVDD = 1.65V	-	-	0.8 0.50	V
Input characteristics (Schmitt)	Pin:	SCLK0, SIN0, DBGDT, VBUSFLG				
“H” level trigger voltage	VT1+	HVDD = 3.6V	1.4	-	2.7	V
“L” level trigger voltage	VT1-	HVDD = 3.0V	0.6	-	1.8	V
Hysteresis voltage	$\Delta V1$	HVDD = 3.0V	0.3	-	-	V
Schmitt input characteristics (USB: FS)	Pin:	DP, DM				
“H” level trigger voltage	VTU+	HVDD = 3.6V	1.1	-	1.8	V
“L” level trigger voltage	VTU-	HVDD = 3.0V	1.0	-	1.5	V
Hysteresis voltage	$\Delta VU$	HVDD = 3.0V	0.1	-	-	V
Input characteristics (USB:FS differential input)	Pin:	DP, DM pair				
Differential input sensitivity	VDSU	HVDD = 3.0V Differential input voltage 0.8V to 2.5V	-	-	0.2	V
Input characteristics	Pin:	SCLK0, SIN0, DBGDT				
Pull-up resistance	RPLU1H	VI = HVDD	25	50	120	k $\Omega$
Input characteristics	Pin:	HINTRQ_T, XHDASP_T, XHPDIAG_T, VBUSFLG				
Pull-up resistance	RPLU2H	VI = HVDD or IOVDD	50	100	240	k $\Omega$
Input characteristics	Pin:	ATPGEN, BURNIN				
Pull-down resistance	RPLD1L	VI = LVDD	24	60	150	k $\Omega$
Input characteristics	Pin:	TSTEN				
Pull-down resistance	RPLD2L	VI = LVDD	48	120	300	k $\Omega$
Input characteristics	Pin:	VBUS				
Pull-down resistance	RPLDB	VI = 5.0V	110	125	150	k $\Omega$

## 8.3.3 Output Characteristics

(V<sub>SS</sub>=0V)

Item	Code	Conditions	MIN	TYP	MAX	Units
Output characteristics	Pin:	HDD_T[15:0], HDMARQ_T, HIORDY_T, HINTRQ_T, XHDASP_T, XHPDIAG_T				
"H" level output voltage	VOH1	IOVDD = 3.0V IOH = -4.0mA IOVDD = 1.65V IOH = -2.0mA	IOVDD - 0.4	-	-	V
"L" level output voltage	VOL1	IOVDD = 3.0V IOL = 4.0mA IOVDD = 1.65V IOL = 2.0mA	-	-	0.4	V
Output characteristics	Pin:	PORT10, PORT11, PORT12, PORT13, PORT14, PORT15, PORT16, PORT17				
"H" level output voltage	VOH2	IOVDD = 3.0V IOH = -2.0mA IOVDD = 1.65V IOH = -1.0mA	IOVDD - 0.4	-	-	V
"L" level output voltage	VOL2	IOVDD = 3.0V IOL = 2.0mA IOVDD = 1.65V IOL = 1.0mA	-	-	0.4	V
Output characteristics	Pin:	SOUT0, DBGDCLK, DBGDT, DBGST				
"H" level output voltage	VOH3	HVDD = 3.0V IOH = -4.0mA	HVDD - 0.4	-	-	V
"L" level output voltage	VOL3	HVDD = 3.0V IOL = 4.0mA	-	-	0.4	V
Output characteristics	Pin:	VBUSEN				
"H" level output voltage	VOH4	HVDD = 3.0V IOH = -2.0mA	HVDD - 0.4	-	-	V
"L" level output voltage	VOL4	HVDD = 3.0V IOL = 2.0mA	-	-	0.4	V
Output characteristics (USB:FS)	Pin:	DP, DM				
"H" level output voltage	VOHUF	HVDD = 3.0V	2.8	-	-	V
"L" level output voltage	VOLUF	HVDD = 3.6V	-	-	0.3	V
Output characteristics (USB:HS)	Pin:	DP, DM				
"H" level output voltage	VOHUH	HVDD = 3.0V	360	-	-	mV
"L" level output voltage	VOLUH	HVDD = 3.6V	-	-	10.0	mV
Output characteristics	Pin:	HDD_T[15:0], HDMARQ_T, HIORDY_T, HINTRQ_T, XHDASP_T, XHPDIAG_T, SCLK0, SIN0, DBGDT				
OFF-STATE leakage	IOZ	HVDD, IOVDD = 3.6V VOH = HVDD or IOVDD VOL = VSS	-5	-	5	μA

## 8. Electrical Characteristics

---

### 8.3.4 Pin Capacitance

Item	Code	Conditions	MIN	TYP	MAX	Units
Pin capacitance	Pin:	All input pins				
Input pin capacitance	CI	f = 1MHz HVDD = IOVDD = LVDD = VSS	-	-	8	pF
Pin capacitance	Pin:	All output pins				
Output pin capacitance	CO	f = 1MHz HVDD = IOVDD = LVDD = VSS	-	-	8	pF
Pin capacitance	Pin:	Input/output pins except DP and DM				
Input/output pin capacitance	CB	f = 1MHz HVDD = IOVDD = LVDD = VSS	-	-	8	pF
Pin capacitance	Pin:	DP and DM				
Input/output pin capacitance (USB)	CBU	f = 1MHz HVDD = IOVDD = LVDD = VSS	-	-	11	pF

## 8.4 AC Characteristics

### 8.4.1 Reset Timing

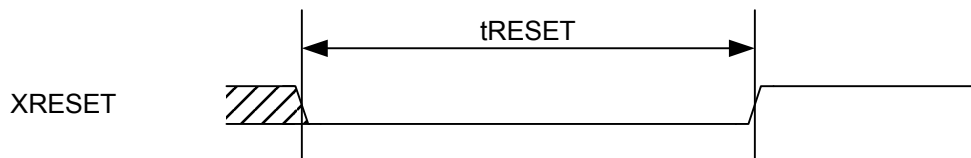

Code	Details	Min	Typ	Max	Units
$t_{RESET}$	Reset pulse width	40	-	-	ns

### 8.4.2 Clock Timing

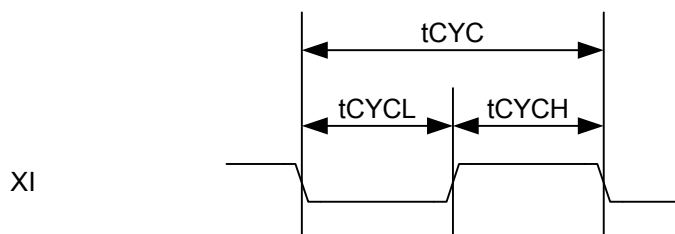

Code	Details	Min	Typ	Max	Units
$t_{CYC}$	Clock cycle (CLKSEL = "L")	11.9988	12.000	12.0012	MHz
$t_{CYC}$	Clock cycle (CLKSEL = "H")	23.9976	24.000	24.0024	MHz
$t_{CYCL}$ $t_{CYCH}$	Clock duty	45	50	55	%

## 8. Electrical Characteristics

---

### 8.4.3 USB I/F Timing

Complies with *USB 2.0 Universal Serial Bus Specification Revision 2.0* standards.

### 8.4.4 IDE Device I/F Timing

Complies with *ATA Attachment with Packet Interface – 6 (ATA/ATAPI-6)* standards.

## 8.4.5 CPUIF Timing (PIO)

PIO read/write

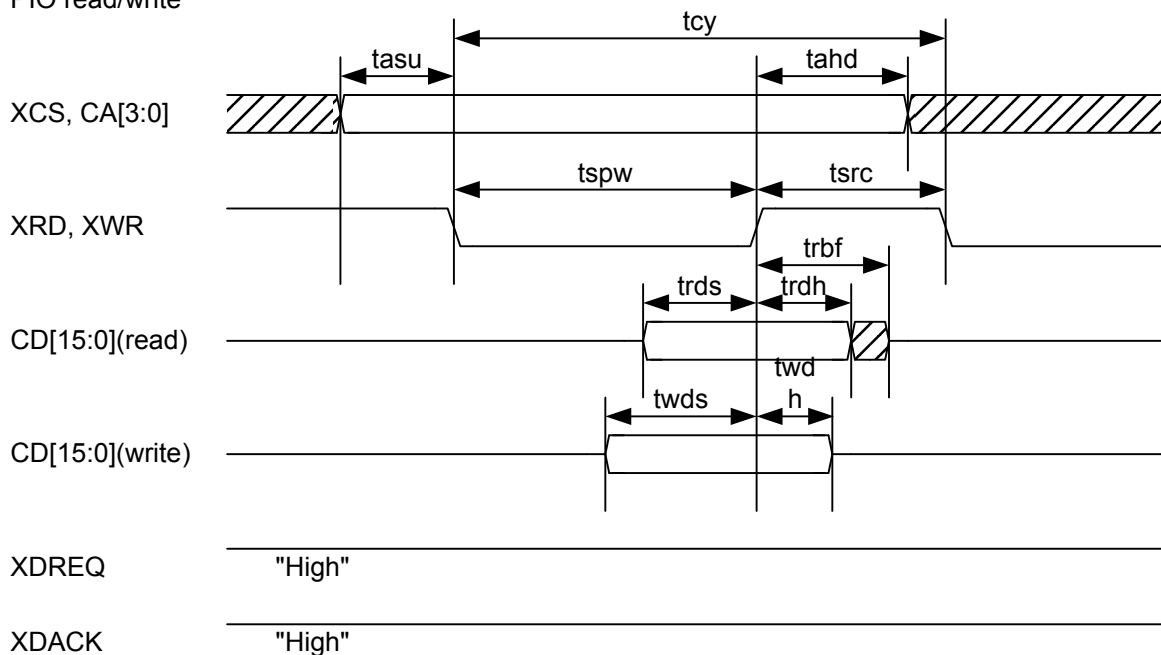

Code	Details	Min	Typ	Max	Units
tcy	Cycle	120/130	-	-	ns
tasu	Address setup	25/30	-	-	ns
tspw	XRD/XWR pulse width	70/75	-	-	ns
tsrc	XRD/XWR recovery	25/30	-	-	ns
trds	Read data setup	20/15	-	-	ns
trdh	Read data hold	5/5	-	-	ns
trbf	Bus release	-	-	30/30	ns
twds	Write data setup	20/25	-	-	ns
twdh	Write data set hold	10/10	-	-	ns
tahd	Address hold	10/10	-	-	ns

\* When using IOVDD = 3.0 V to 3.6 V / When using IOVDD = 1.8 V to 3.0 V (wide range)

## S1R72U16\*\*\*E200 AC characteristics

Code	Details	Min	Typ	Max	Units
trdh	Read data hold time	5/5 *1	-	-	ns
tahd	Address hold time	0/0	-	-	ns

\* When using IOVDD = 3.0 V to 3.6 V / When using IOVDD = 1.8 V to 3.0 V (wide range)

\*1: The read data hold time will be 0 ns for address changes if the address hold time is less than 5 ns.

Note: The definition of AC shown above uses the description format specified in ATA standards. Consider the valid data output start time in a read operation as follows:

70 (XRD pulse width: min) - 20 (read data setup: min) = 50 ns (when IOVDD = 3.0 to 3.6 V)

## 8. Electrical Characteristics

### 8.4.6 CPUIF Timing (DMA)

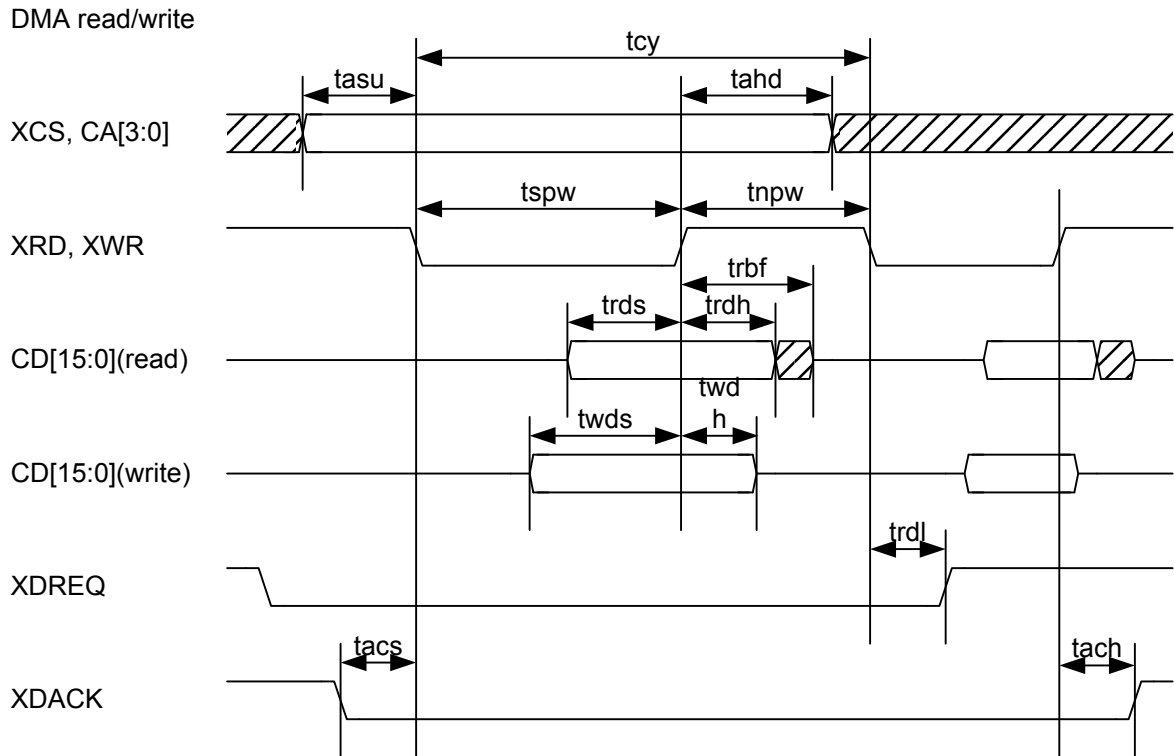

Code	Details	Min	Typ	Max	Units
tcy	Cycle	120/130	-	-	ns
tasu	Address setup	25/25	-	-	ns
tspw	XRD/XWR pulse width	70/75	-	-	ns
tspw	XRD/XWR negate pulse width	25/30	-	-	ns
trds	Read data setup	20/15	-	-	ns
trdh	Read data hold	5/5	-	-	ns
trbf	Bus release	-	-	30/30	ns
twds	Write data setup	20/25	-	-	ns
twdh	Write data set hold	10/10	-	-	ns
tahd	Address hold	10/10	-	-	ns
trdl	XDREQ delay	-	-	35/45	ns
tacs	XDACK setup	0/0	-	-	ns
tach	XDACK hold	5/5	-	-	ns

\* When using IOVDD = 3.0 V to 3.6 V / When using IOVDD = 1.8 V to 3.0 V (wide range)

#### S1R72U16\*\*\*E200 AC characteristics

Code	Details	Min	Typ	Max	Units
trdh	Read data hold time	5/5 *1	-	-	ns
tahd	Address hold time	0/0	-	-	ns

\* When using IOVDD = 3.0 V to 3.6 V / When using IOVDD = 1.8 V to 3.0 V (wide range)

\*1: The read data hold time will be 0 ns for address changes if the address hold time is less than 5 ns.

Note: The definition of AC shown above uses the description format specified in ATA standards. Consider the valid data output start time in a read operation as follows:

70 (XRD pulse width: min) -20 (read data setup: min) = 50 ns (when IOVDD = 3.0 to 3.6 V)

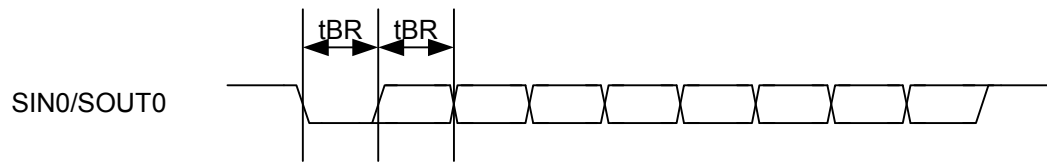
**8.4.7 Serial I/F Timing**

Code	Detail	Min	Typ	Max	Unit
tBR	Baud rate	-	19200	-	bps

### **9. Connection Examples**

Refer to the *S1R72U16 Evaluation Board Manual* for USB I/F, IDE I/F, CPU I/F (in CPU mode), and Serial I/F connection examples.

## 10. External Dimensions Diagram

### 10.1 PFBGA8UX81

#### Top View

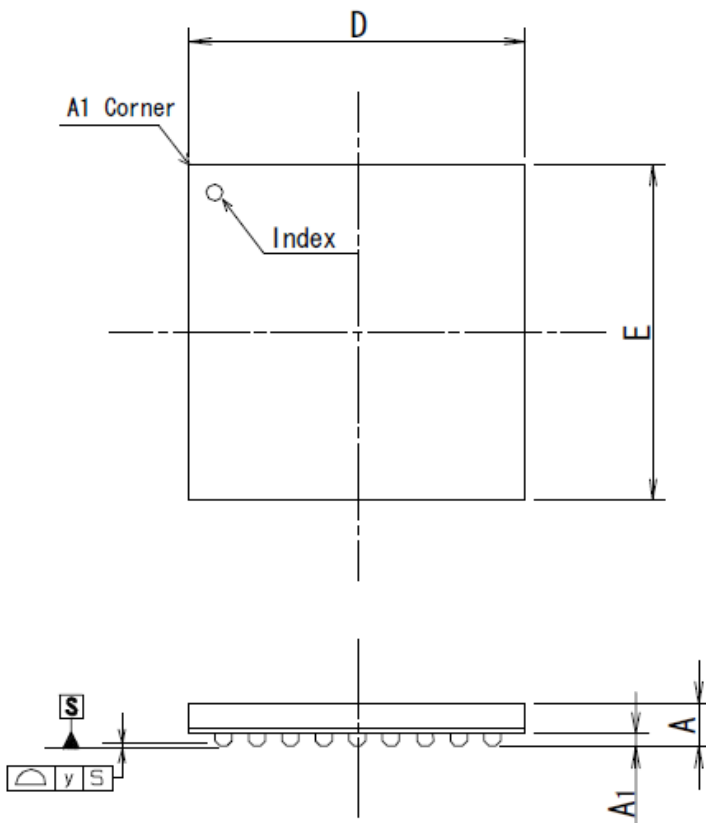

#### Bottom View

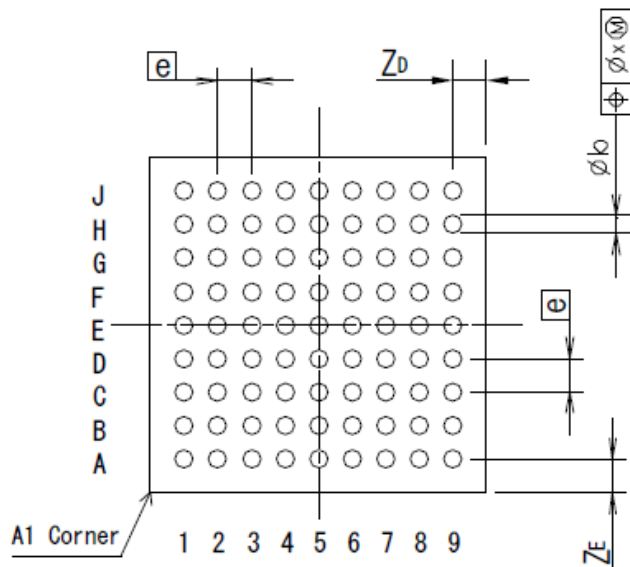

Symbol	Dimension in Millimeters		
	Min	Nom	Max
D	-	8	-
E	-	8	-
A	-	-	1.2
A <sub>1</sub>	-	0.3	-
e	-	0.8	-
b	0.38	-	0.48
x	-	-	0.08
y	-	-	0.1
Z <sub>D</sub>	-	0.8	-
Z <sub>E</sub>	-	0.8	-

# 10. External Dimensions Diagram

## 10.2 QFP14-80

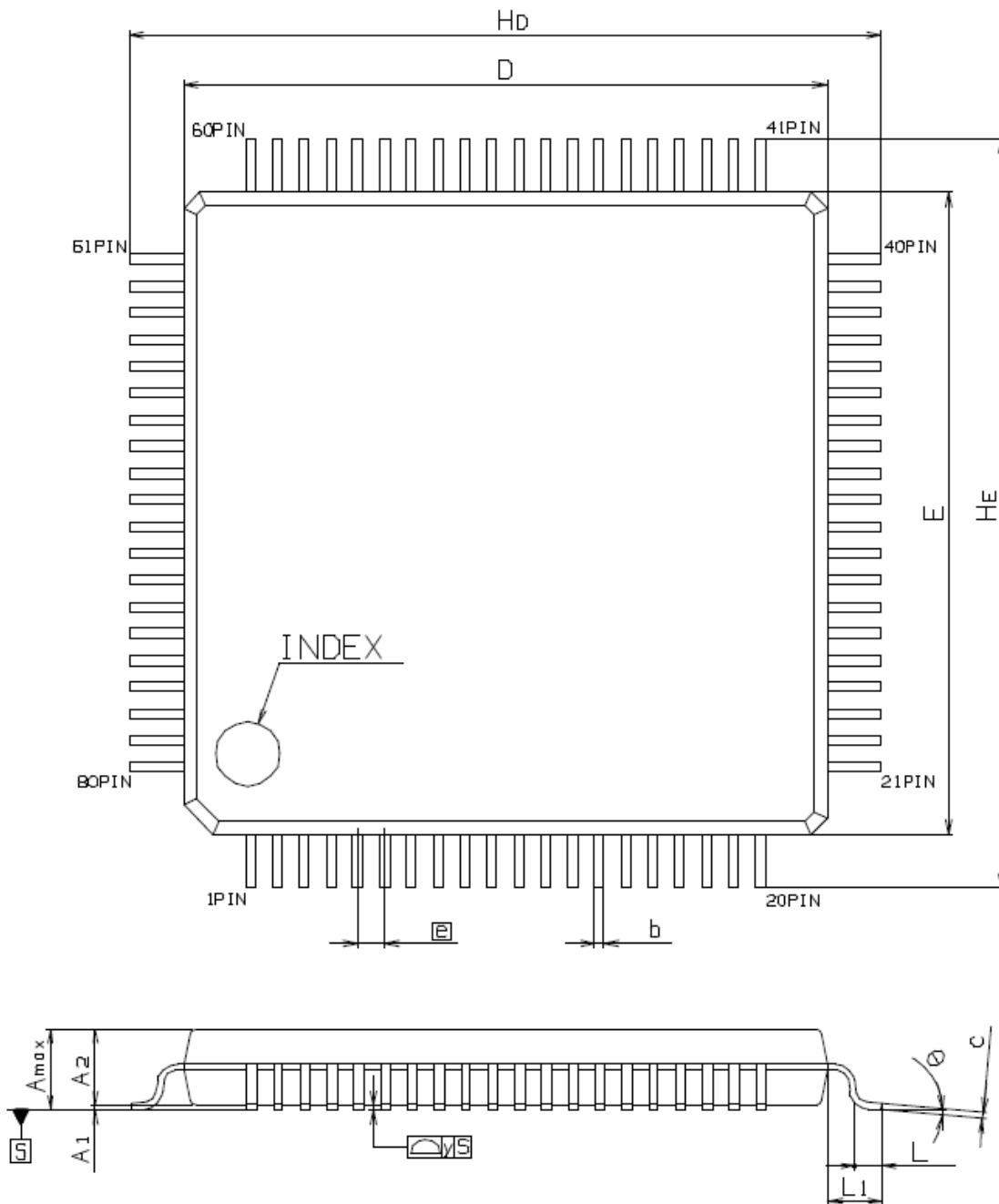

Symbol	Dimension in Millimeters		
	Min	Nom	Max
E	-	12	-
D	-	12	-
A <sub>max</sub>	-	-	1.7
A <sub>1</sub>	-	0.1	-
A <sub>2</sub>	-	1.4	-
ⓔ	-	0.5	-
b	0.13	-	0.27
c	0.09	-	0.2
θ	0°	-	10°
L	0.3	-	0.75
L <sub>1</sub>	-	1	-
HE	-	14	-
Hd	-	14	-
y	-	-	0.08

---

## 11. Product Codes

**Table 11.1 Product codes**

Product code	Details
S1R72U16B08E100 S1R72U16B08E200	PFBGA8UX81 package
S1R72U16F14E100 S1R72U16F14E200	QFP14-80 package

## Revision History

### Revision History

	Rev.	Page	Type	Details
05/14/2007	0.79	All pages	New	Newly established
07/01/2007	1.00	8.3.1 8.3.2 8.3.3 8.4.5 8.4.6 8.4.7	Addition Addition Addition Addition Addition Addition	Spec. added Spec. added(IOVDD=1.8V) Spec. added(IOVDD=1.8V) Spec. added Spec. added Serial I/F Timing added
10/15/2007	1.10	Scope	Add	Added "notice."
		2	Correct	Changed "IDE driver" to "ATA/ATAPI driver."
		6.1 and 6.2	Correct	Changed setting of unused terminal from "open" to "open or pull-up."
		8.4.2	Correct	Spec. corrected as follows: "11.999" to "11.9988" "12.001" to "12.0012" "23.998" to "23.9976" "24.002" to "24.0024"
		8.4.5 and 8.4.6	Add	Added note regarding valid data output start time.
04/21/2008	2.00	8.4.5 8.4.6	Addition	Added S1R72U16***E200 timing.
		11	Addition	Added S1R72U16***E200 product code.

### AMERICA

---

**EPSON ELECTRONICS AMERICA, INC.****HEADQUARTERS**

2580 Orchard Parkway  
San Jose, CA 95131, USA  
Phone: +1-800-228-3964 FAX: +1-408-922-0238

**SALES OFFICES****Northeast**

301 Edgewater Place, Suite 210  
Wakefield, MA 01880, U.S.A.  
Phone: +1-800-922-7667 FAX: +1-781-246-5443

### EUROPE

---

**EPSON EUROPE ELECTRONICS GmbH****HEADQUARTERS**

Riesstrasse 15 Muenchen Bayern, 80992 GERMANY  
Phone: +49-89-14005-0 FAX: +49-89-14005-110

### ASIA

---

**EPSON (CHINA) CO., LTD.**

7F, Jinbao Bldg., No.89 Jinbao St., Dongcheng District,  
Beijing 100005, China  
Phone: +86-10-6410-6655 FAX: +86-10-6410-7320

**SHANGHAI BRANCH**

7F, Block B, Hi-Tech Bldg., 900, Yishan Road,  
Shanghai 200233, CHINA  
Phone: +86-21-5423-5522 FAX: +86-21-5423-5512

**EPSON HONG KONG LTD.**

20/F., Harbour Centre, 25 Harbour Road  
Wanchai, Hong Kong  
Phone: +852-2585-4600 FAX: +852-2827-4346  
Telex: 65542 EPSCO HX

**EPSON (CHINA) CO., LTD.****SHENZHEN BRANCH**

12/F, Dawning Mansion, Keji South 12th Road,  
Hi-Tech Park, Shenzhen  
Phone: +86-755-2699-3828 FAX: +86-755-2699-3838

**EPSON TAIWAN TECHNOLOGY & TRADING LTD.**

14F, No. 7, Song Ren Road,  
Taipei 110  
Phone: +886-2-8786-6688 FAX: +886-2-8786-6660

**EPSON SINGAPORE PTE., LTD.**

1 HarbourFront Place,  
#03-02 HarbourFront Tower One, Singapore 098633  
Phone: +65-6586-5500 FAX: +65-6271-3182

**SEIKO EPSON CORPORATION****KOREA OFFICE**

50F, KLI 63 Bldg., 60 Yoido-dong  
Youngdeungpo-Ku, Seoul, 150-763, KOREA  
Phone: +82-2-784-6027 FAX: +82-2-767-3677

**GUMI OFFICE**

2F, Grand B/D, 457-4 Songjeong-dong,  
Gumi-City, KOREA  
Phone: +82-54-454-6027 FAX: +82-54-454-6093

---

**SEIKO EPSON CORPORATION****SEMICONDUCTOR OPERATIONS DIVISION****IC Sales Dept.****IC International Sales Group**

421-8, Hino, Hino-shi, Tokyo 191-8501, JAPAN  
Phone: +81-42-587-5814 FAX: +81-42-587-5117

## Looking for pricing, stock, or lifecycle information?

Click below to explore more details on WIN SOURCE:

- ⊖ [View S1R72U16B08E200 on WIN SOURCE](#)
- ⊖ [Epson Electronics America Inc-Semiconductor Div Information](#)

## Optimize Your Supply Chain with WIN SOURCE Solutions

- ✓ Global Sourcing Solution
- ✓ Obsolete Management
- ✓ Cost Control Management
- ✓ Shortage Management
- ✓ Alternative Solution
- ✓ Excess Inventory Management