



**THE DATASHEET OF  
RT9302GJ8**



# 60mA 3-Channel Pulse Dimming Current Source LED Driver

## General Description

The RT9302 is a high performance constant current driver for white LED. It supports up to 3 white LEDs and regulates a constant current for uniform intensity. Each channel supports up to 20mA output current with 1% typical current accuracy and 0.7% typical current matching. The RT9302 provides a 16-step brightness dimming control. The LED current can be easily configured from 1.25mA to 20mA. The dimming of white LEDs' current can be achieved by applying a pulse signal to the EN pin. The LED current can be turned off by EN pin with pull low for 20μs or longer. The typical leakage current is 4μA while shutdown condition.

RT9302 is available in a TSOT-23-8 package (1.0mm maximum height).

## Ordering Information

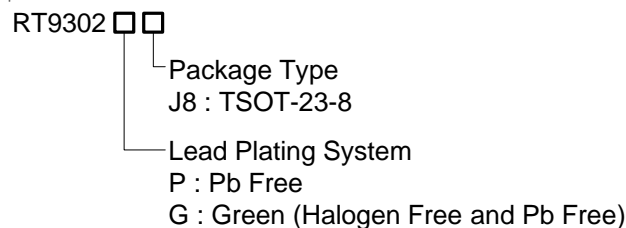

Note :

Richtek products are :

- ▶ RoHS compliant and compatible with the current requirements of IPC/JEDEC J-STD-020.
- ▶ Suitable for use in SnPb or Pb-free soldering processes.

## Marking Information

For marking information, contact our sales representative directly or through a Richtek distributor located in your area.

## Features

- Support Up to 3 White LEDs
- Output Current up to 20mA Each Channel
- Support Pulse and PWM Dimming
- 40mV Typical Current Source Dropout
- 1% Typical LED Current Accuracy
- 0.7% Typical LED Current Matching
- 16-Step Brightness Control
- Low Noise and EMI
- Low Shutdown Current 4μA Typical
- RoHS Compliant and 100% Lead (Pb)-Free

## Applications

- Mobile Phone, DSC, MP3
- White LED Backlighting
- LCD Display Supply

## Pin Configurations

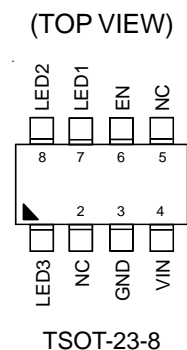

Typical Application Circuit

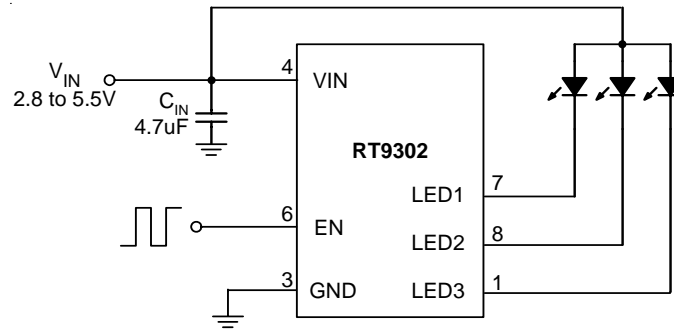

Figure 1. For 3-WLEDs Application Circuit

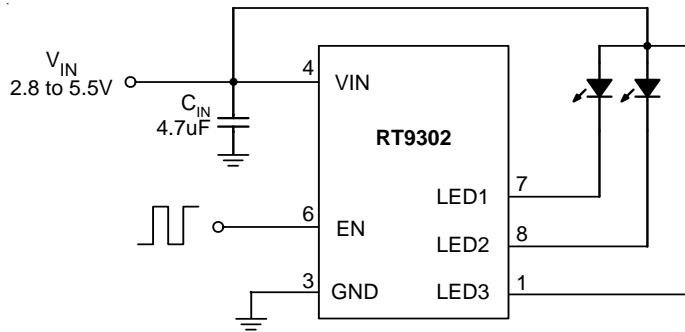

Figure 2. For 2-WLEDs Application Circuit

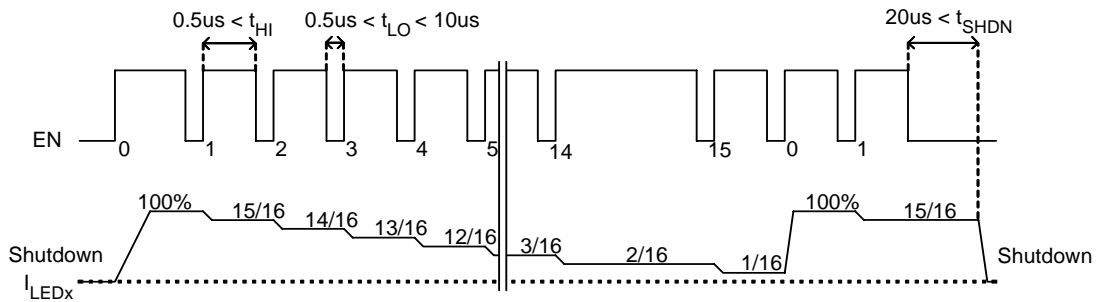
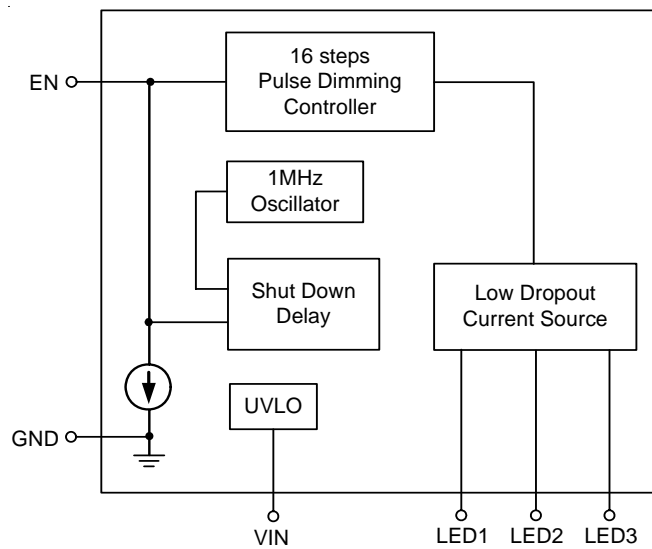

Figure 3. Brightness control by pulse dimming. RT9302 implements 16 steps brightness control

**Functional Pin Description**

Pin Number	Pin Name	Pin Function
1	LED3	Current Sink for LED3. (If not in use, this pin must be connected to VIN)
2, 5	NC	No Internal Connection.
3	GND	Power Ground.
4	VIN	Input Voltage.
6	EN	Chip Enable.
7	LED1	Current Sink for LED1. (If not in use, this pin must be connected to VIN)
8	LED2	Current Sink for LED2. (If not in use, this pin must be connected to VIN)

**Function Block Diagram**



## Absolute Maximum Ratings (Note 1)

- Supply Input Voltage ----- -0.3V to 6V
- Other I/O Pin Voltages ----- -0.3V to 6V
- VIN, EN to GND ----- 6V
- Power Dissipation,  $P_D$  @  $T_A = 25^\circ\text{C}$   
 TSOT-23-8 ----- 0.455W
- Package Thermal Resistance (Note 2)  
 TSOT-23-8,  $\theta_{JA}$  -----  $220^\circ\text{C/W}$
- Lead Temperature (Soldering, 10 sec.) -----  $260^\circ\text{C}$
- Junction Temperature -----  $150^\circ\text{C}$
- Storage Temperature Range -----  $-65^\circ\text{C}$  to  $150^\circ\text{C}$
- ESD Susceptibility (Note 3)  
 HBM (Human Body Mode) ----- 2kV  
 MM (Machine Mode) ----- 200V

## Recommended Operating Conditions (Note 4)

- Junction Temperature Range -----  $-40^\circ\text{C}$  to  $125^\circ\text{C}$
- Ambient Temperature Range -----  $-40^\circ\text{C}$  to  $85^\circ\text{C}$

## Electrical Characteristics

( $V_{IN} = 3.6\text{V}$ ,  $C_{IN} = 1\mu\text{F}$ ,  $\text{ESR} = 0.03\Omega$ ,  $V_F = 3.4\text{V}$ ,  $I_{LED1} = I_{LED2} = I_{LED3} = 20\text{mA}$ ,  $T_A = 25^\circ\text{C}$ , unless otherwise specified)

Parameter	Symbol	Test Conditions	Min	Typ	Max	Unit
<b>Input</b>						
Input Supply Voltage	$V_{IN}$		2.8	--	5.5	V
Under Voltage Lockout Threshold		$V_{IN}$ falling	--	2.0	--	V
Under Voltage Lockout Hysteresis			--	200	--	mV
Shutdown Current	$I_{SHDN}$	$V_{EN} = 0\text{V}$	--	4	10	$\mu\text{A}$
Quiescent Current	$I_Q$	$V_{EN} = \text{High}$ , $I_{OUT} = 0$	--	0.4	--	mA
<b>Output</b>						
Output Current	$I_{LED}$	100% setting, $V_{LED} = 1\text{V}$	18.4	20	21.6	mA
Current Matching	$I_{LED-LLED}$	100% setting, $V_{LED} = 1\text{V}$	-5	0	+5	%
Dropout Voltage	$V_{LED}$	90% of full output current	--	40	150	mV
<b>Enable</b>						
EN Threshold Voltage	Logic-High	$V_{IH}$	1.5	--	--	V
	Logic-Low	$V_{IL}$	--	--	0.4	
Time of EN Logic	Logic-High	$T_{HI}$	0.5	--	--	$\mu\text{s}$
	Logic-Low	$T_{LO}$	0.5	--	10	
Shutdown Delay	$T_{SHDN}$	From EN Low to Shutdown	10	16	20	$\mu\text{s}$
EN Input Current	$I_{EN}$	$V_{EN} = 1.8\text{V}$	--	1	--	$\mu\text{A}$

**Note 1.** Stresses listed as the above “Absolute Maximum Ratings” may cause permanent damage to the device. These are for stress ratings. Functional operation of the device at these or any other conditions beyond those indicated in the operational sections of the specifications is not implied. Exposure to absolute maximum rating conditions for extended periods may remain possibility to affect device reliability.

**Note 2.**  $\theta_{JA}$  is measured in the natural convection at  $T_A = 25^\circ\text{C}$  on a low effective thermal conductivity test board of JEDEC 51-3 thermal measurement standard.

**Note 3.** Devices are ESD sensitive. Handling precaution recommended.

**Note 4.** The device is not guaranteed to function outside its operating conditions.

Typical Operating Characteristics

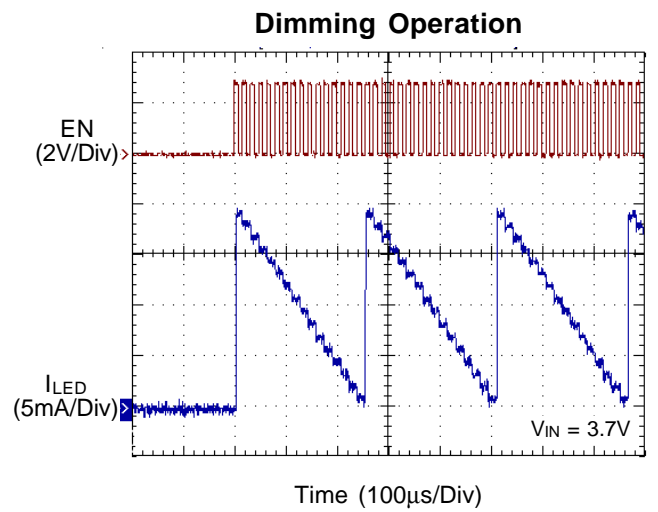
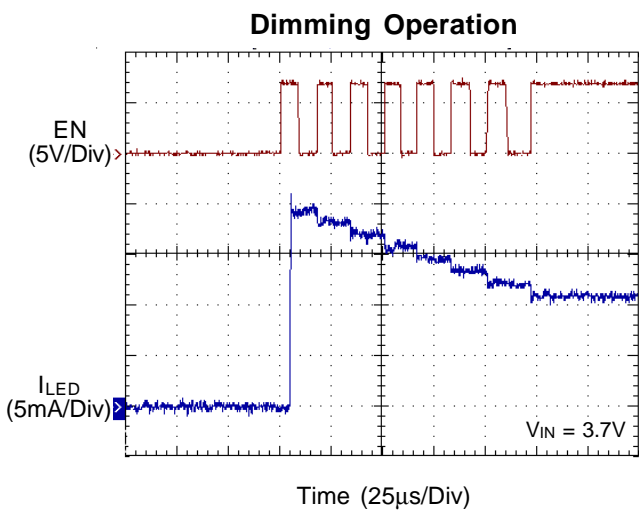
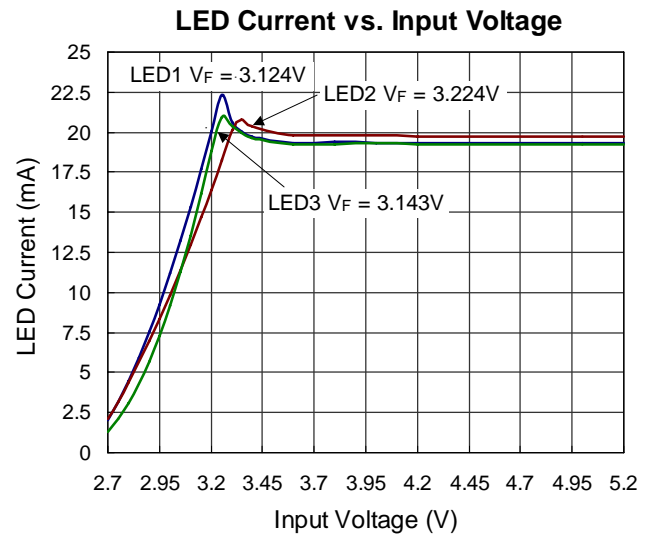
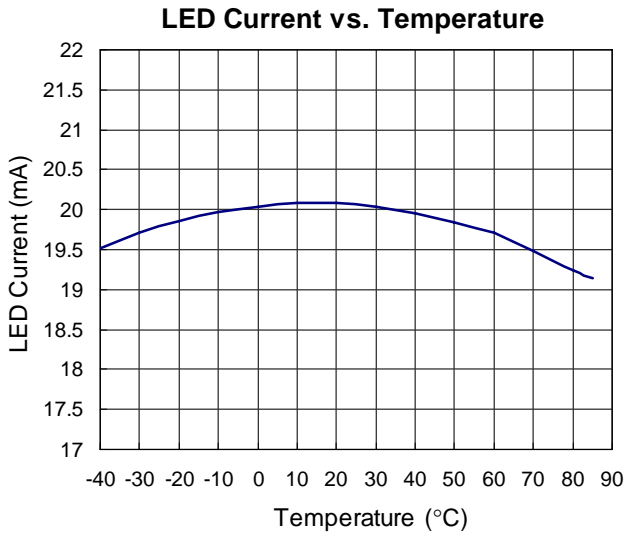
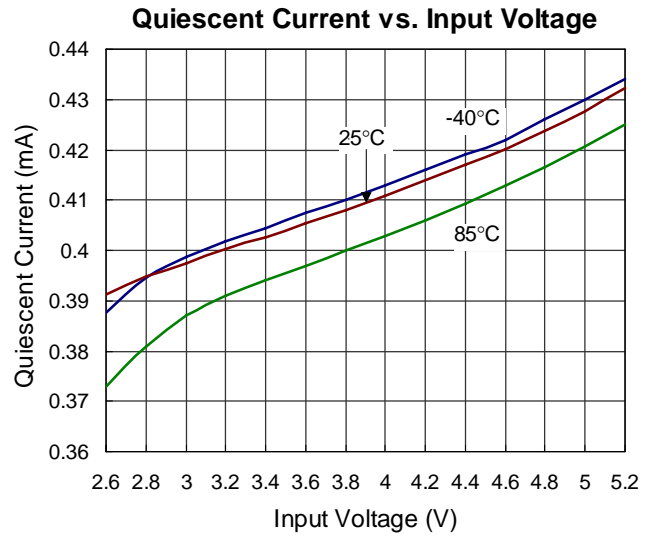
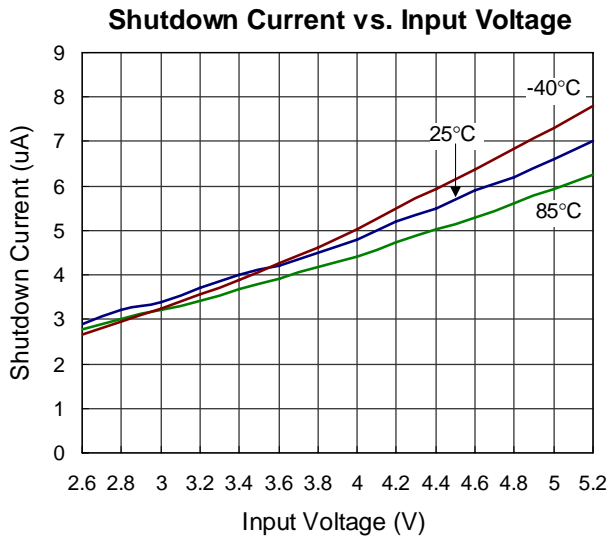

Dimming Operation

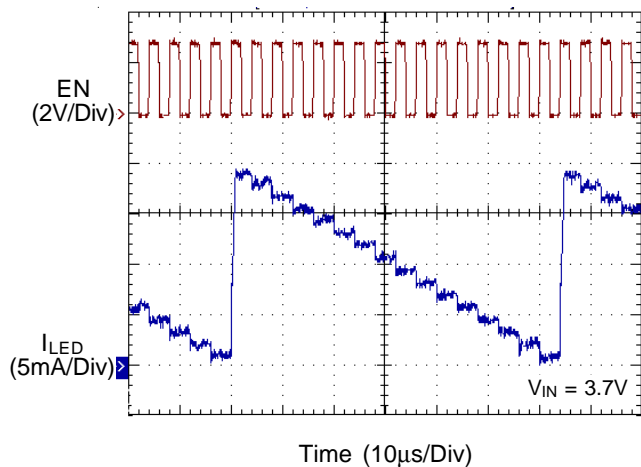

Turn-On

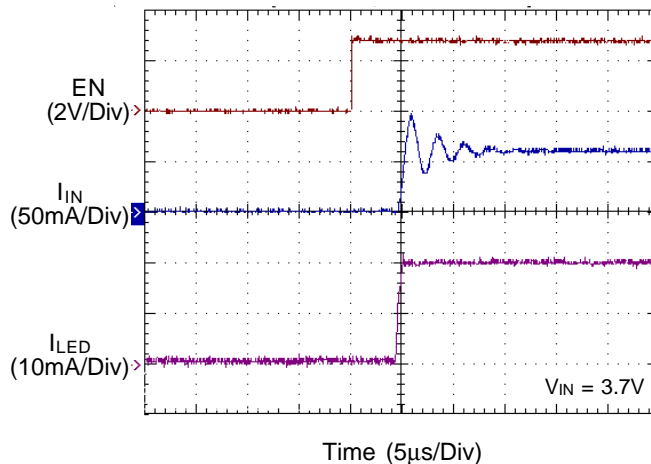

Turn-Off

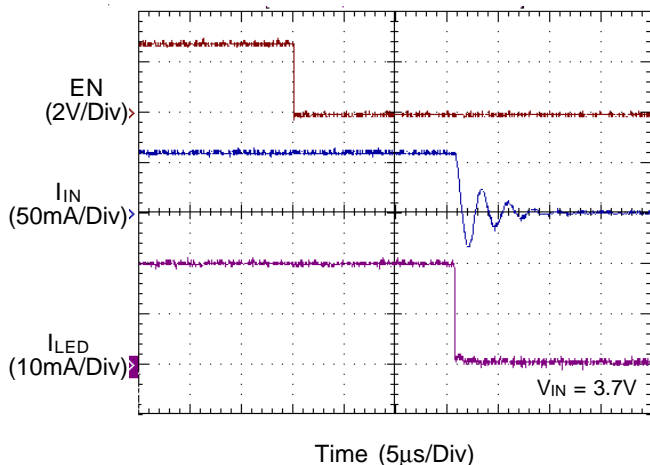

## Application Information

### Input UVLO

The input operating voltage range of the RT9302 is 2.8V to 5.5V. An input capacitor at the VIN pin could reduce ripple voltage. It is recommended to use a ceramic 1μF or larger capacitance as the input capacitor. This IC provides an under voltage lockout (UVLO) function to prevent it from unstable issue when startup. The UVLO threshold of input falling voltage is set at 2V typically with a hysteresis 0.2V.

### Output Current

RT9302 provides a constant output current for white LED. Figure 1 shows a typical application circuit for 3 white LEDs. Each channel supports up to 20mA output current and regulates a constant current for uniform intensity. For two or one LED application, the non-used channel must be connected to VIN as shown in Figure 2.

### Brightness Dimming Control

The RT9302 provides a 16-step brightness dimming control. The LED current can be easily configured from 1.25mA to 20mA. The dimming of white LEDs' current can be achieved by applying a pulse signal to the EN pin. Figure 3 shows the configuration of the 16-step pulse dimming control operation. The output current is set at 100% of 20mA typical output current when EN pin pull high initially from shutdown condition. The step change of pulse dimming can be implemented by EN pin changing with a logic Low pulse. Each step change 1/16 of full output current setting. The output current change of pulse dimming is designed in decreasing sequence in terms of (16/16, 15/16, ....., 1/16) and then (16/16, 15/16, .....) cycle by cycle. The duration of logic Low pulse is between 0.5us and 10μs. The duration of EN logic High pulse should be longer than 0.5μs.

The LED current can be turned off by EN pin with pulling low for 20μs or longer. The typical leakage current is 4μA while shutdown condition.

### Layout Consideration

For best performance, careful PCB layout is necessary. All peripheral components should be placed as close to

the IC as possible. A short connection is highly recommended. The following guidelines should be strictly followed when designing a PCB layout for the RT9302.

1. All the traces of LED and VIN running from chip to LEDs should be wide and short to reduce the parasitic connection resistance.
2. Input capacitor (C<sub>IN</sub>) should be placed close to VIN and connected to ground plane. The anodes of LEDs must be connected to C<sub>IN</sub>, not battery directly.
3. The GND should be connected to a strong ground plane for heat sinking and noise protection.

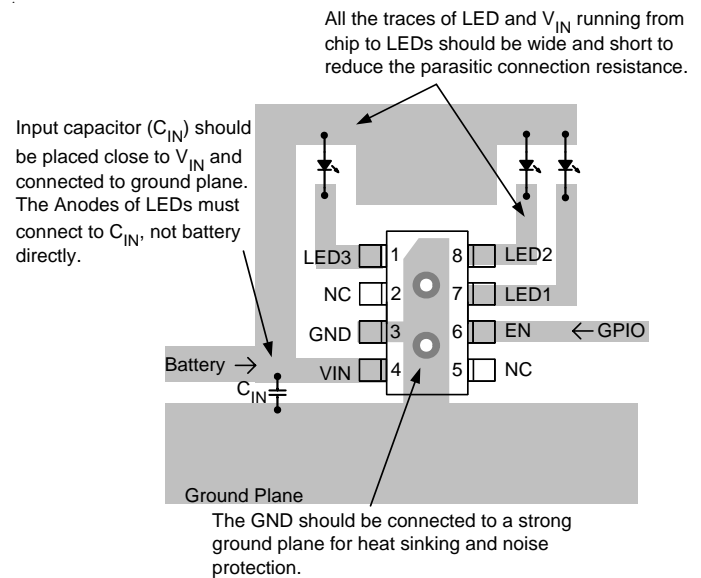
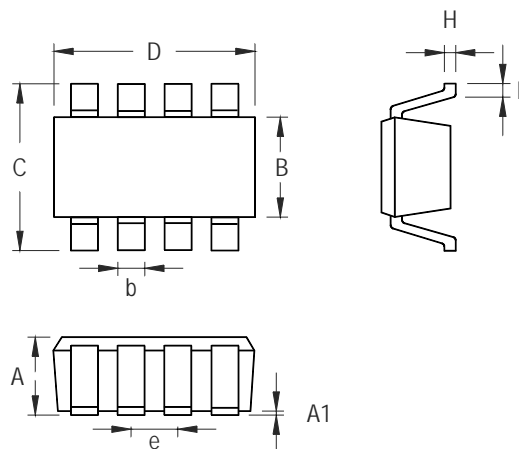

Figure 4. PCB Layout Guide

**Outline Dimension**



Symbol	Dimensions In Millimeters		Dimensions In Inches	
	Min	Max	Min	Max
A	0.700	1.000	0.028	0.039
A1	0.000	0.100	0.000	0.004
B	1.397	1.803	0.055	0.071
b	0.220	0.380	0.009	0.015
C	2.591	3.000	0.102	0.118
D	2.692	3.099	0.106	0.122
e	0.585	0.715	0.023	0.028
H	0.080	0.254	0.003	0.010
L	0.300	0.610	0.012	0.024

**TSOT-23-8 Surface Mount Package**

**Richtek Technology Corporation**

Headquarter  
 5F, No. 20, Taiyuen Street, Chupei City  
 Hsinchu, Taiwan, R.O.C.  
 Tel: (8863)5526789 Fax: (8863)5526611



**Richtek Technology Corporation**

Taipei Office (Marketing)  
 5F, No. 95, Minchiuan Road, Hsintien City  
 Taipei County, Taiwan, R.O.C.  
 Tel: (8862)86672399 Fax: (8862)86672377  
 Email: marketing@richtek.com

Information that is provided by Richtek Technology Corporation is believed to be accurate and reliable. Richtek reserves the right to make any change in circuit design, specification or other related things if necessary without notice at any time. No third party intellectual property infringement of the applications should be guaranteed by users when integrating Richtek products into any application. No legal responsibility for any said applications is assumed by Richtek.

## Looking for pricing, stock, or lifecycle information?

Click below to explore more details on WIN SOURCE:

-  [View RT9302GJ8 on WIN SOURCE](#)
-  [Richtek USA Inc. Information](#)

## Optimize Your Supply Chain with WIN SOURCE Solutions

-  Global Sourcing Solution
-  Obsolete Management
-  Cost Control Management
-  Shortage Management
-  Alternative Solution
-  Excess Inventory Management