



**THE DATASHEET OF
RT8532GQW**



6-String 43V White LED Driver with Boost Regulator

General Description

The RT8532 is a high efficiency white LED driver. It is designed for LCD panel that employs a LED array as the lighting source. An integrated switch current mode Boost controller drives six strings in parallel and supports up to 10 pieces of LEDs per string. The internal current sinks support maximum $\pm 2\%$ current matching for excellent brightness uniformity in each LED string. To provide enough headroom for the operating of current sink, the Boost controller monitors the minimum voltage of feedback pins and regulates an optimized output voltage for power efficiency.

The RT8532 has wide input voltage range from 2.5V to 24V and provides adjustable 5mA to 50mA LED current. The internal $200\text{m}\Omega$, 43V power switch with current-mode control provides cycle-by-cycle over current protection. The RT8532 also integrates PWM and analog dimming functions for accurate LED current control. The input PWM dimming frequency can be operated operate from 100Hz to 20kHz without any inrush current in LED.

The RT8532 is available in WQFN-20L 3x3 package.

Features

- **Wide Input Voltage** : V_{IN} 2.5V to 24V
- **High Output Voltage** : V_{OUT} up to 43V
- **Programmable Full Channel Current** from 5mA to 50mA and Matched to 2%
- **Channel Current Regulation with $\pm 3\%$ Accuracy**
- **Dimming Controls**
 - **Direct PWM Dimming up to 20kHz and Minimum On-Time to 500ns**
 - **PWM to Mixed Analog and PWM Dimming up to 20kHz with Maximum 9 bit Resolution**
- **Built-In Soft Start to Prevent Inrush Current without External Capacitor**
- **Disconnects LED in Shutdown**
- **Protection**
 - **Strings Open Detection**
 - **Current Limit Protection**
 - **Programmable Over Voltage Protection**
 - **Over Temperature Protection**
- **20-Lead WQFN Package**
- **RoHS Compliant and Halogen Free**

Applications

- UMPC and Notebook Computer Backlight

Simplified Application Circuit

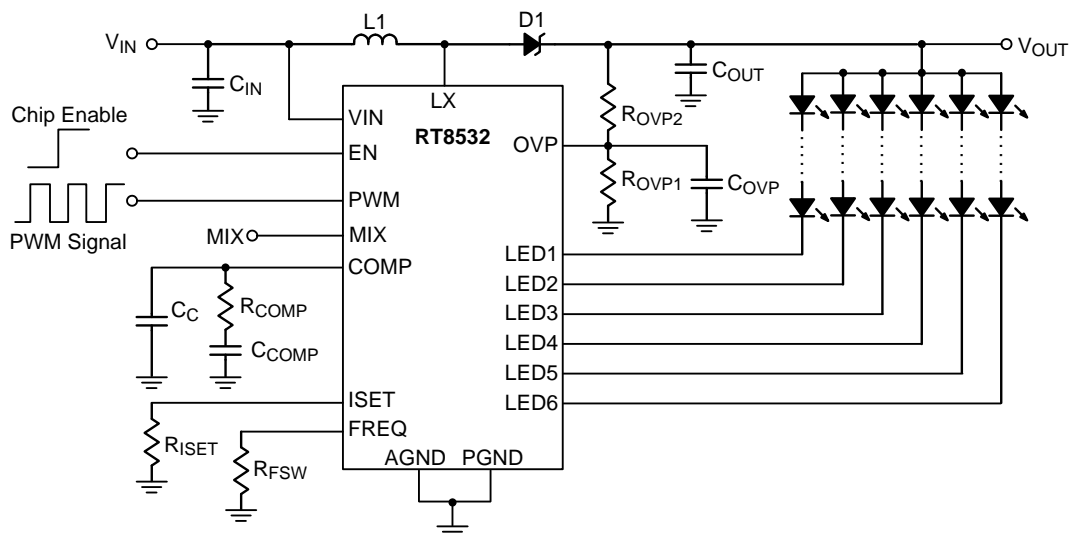

Ordering Information

RT8532

- Package Type
QW : WQFN-20L 3x3 (W-Type)
- Lead Plating System
G : Green (Halogen Free and Pb Free)

Note :

Richtek products are :

- ▶ RoHS compliant and compatible with the current requirements of IPC/JEDEC J-STD-020.
- ▶ Suitable for use in SnPb or Pb-free soldering processes.

Pin Configuration

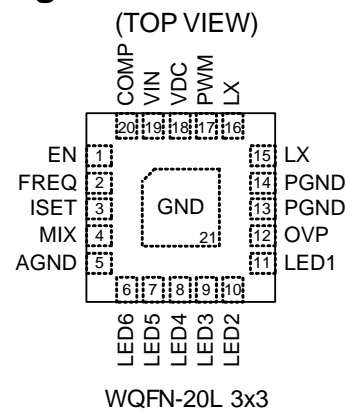

Marking Information

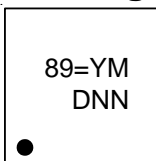

89= : Product Code
YMDNN : Date Code

Functional Pin Description

Pin No.	Pin Name	Pin Function
1	EN	Chip Enable (Active High). There is an internal pull low resistor 400kΩ for the EN pin.
2	FREQ	Switching Frequency of Boost Converter Setting. Connect a resistor between this pin and AGND to set the switching frequency. $R_{FSW} = 1.1 \left(\frac{25}{F_{SW}(\text{MHz})} - 6 \right) \text{ (k}\Omega\text{)}$
3	ISET	LED Current Setting. LED current is set by the resistor R_{ISET} connected from the ISET pin to ground. $I_{LED} \text{ (mA)} = \frac{240}{R_{ISET} \text{ (k}\Omega\text{)}}$
4	MIX	Dimming Mode Selection. There is an internal pull high 400kΩ resistor connected to VDC. Floating or pulling high for 25% Mixed mode dimming, pulling low for direct PWM mode dimming. Recommended to mixed mode for high LED efficiency.
5	AGND	Analog Ground of LED Driver.
6, 7, 8, 9, 10, 11	LED6 to LED1	Current Sink for LED String. (Leave the pin unconnected or short to GND, if not used.)
12	OVP	Over Voltage Protection Sense Input. The detecting threshold is 1.2V (typ.).
13, 14	PGND	Power Ground of Boost Converter.
15, 16	LX	Switching Pin of Boost Converter.
17	PWM	PWM Dimming Control Input.
18	VDC	Internal Regulator Voltage. Connect a capacitor from this pin to ground.
19	VIN	Power Supply Input.
20	COMP	Compensation Note for Boost Converter. Connect a compensation network to this pin for stability.
21 (Exposed Pad)	GND	Ground. The Exposed Pad must be Soldered to a Large PCB and Connected to GND for Maximum Power Dissipation.

Functional Block Diagram

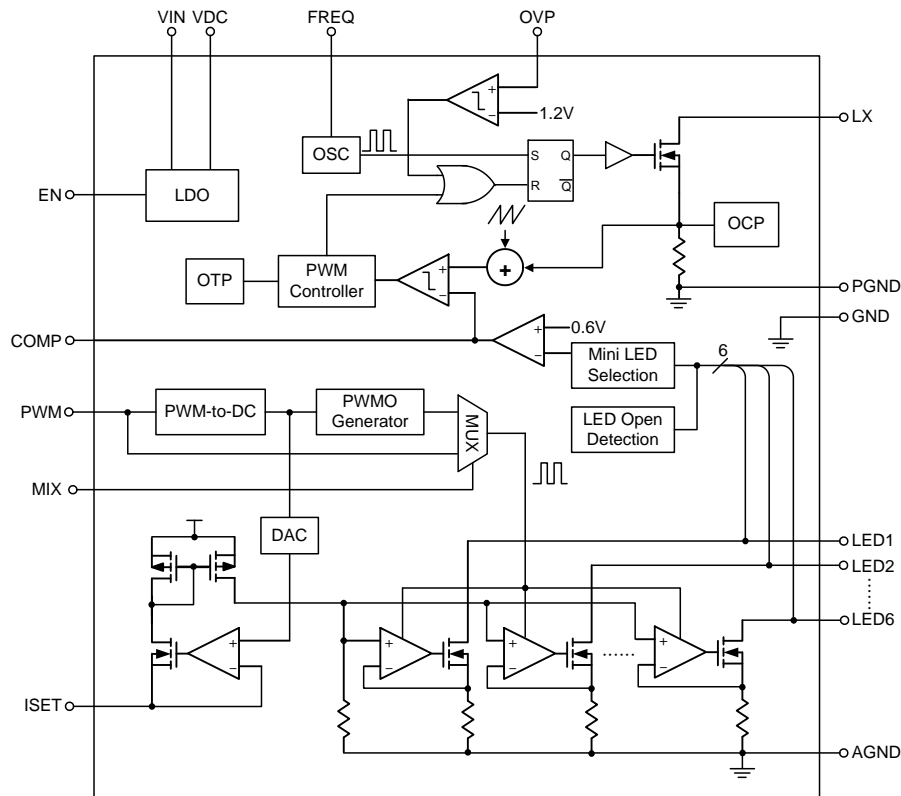

Operation

Enable Control

When VIN is higher than the UVLO voltage and EN pin input voltage is higher than rising threshold, the VDC will be regulated around 3.8V if VIN is higher than 3.8V.

OSC

The switching frequency is adjustable by the external resistor connected between the FREQ pin and GND.

PWM Controller

This controller includes some logic circuit to control LX N-MOSFET on/off. This block controls the minimum on time and max duty of LX.

OCP & OTP

When LX N-MOSFET peak current is higher than 2.5A (typically), the LX N-MOSFET is turned off immediately and resumed again at next clock pulse. When the junction temperature is higher than 150°C (typically), the LX N-

MOSFET will be turned off until the temperature is lower than the 120°C (typically).

OVP

When OVP pin voltage is higher than 1.2V, the LX N-MOSFET is turned off immediately to protect the LX N-MOSFET.

Minimum LED Selection

This block detects all LEDx voltage and select a minimum voltage to EA (Error Amplifier). This function can guarantee the lowest of LED pin voltage is around 600mV and V_{OUT} can be boost to the highest forward voltage of LED strings.

LED Open Detection

If the voltage at LEDx pin is lower than 100mV, this channel is defined as open channel and the Minimum LED Selection function will discard it to regulate other used channels in proper voltage.

Absolute Maximum Ratings (Note 1)

- Supply Input Voltage, VIN to GND ----- -0.3V to 26.5V
- EN, PWM, ISET, COMP, MIX, FREQ to GND ----- -0.3V to 26.5V
- LX, OVP, LED1 to LED6 to GND ----- -0.3V to 48V
- LX to GND ----- -0.3V to 48V
- < 500ns ----- -1V to 48V
- VDC to GND ----- -0.3V to 7V
- Power Dissipation, PD @ TA = 25°C
 - WQFN-20L 3x3 ----- 1.471W
- Package Thermal Resistance (Note 2)
 - WQFN-20L 3x3, θJA ----- 68°C/W
 - WQFN-20L 3x3, θJC ----- 7.5°C/W
- Lead Temperature (Soldering, 10 sec.) ----- 260°C
- Junction Temperature ----- 150°C
- Storage Temperature Range ----- -65°C to 150°C
- ESD Susceptibility (Note 3)
 - HBM (Human Body Model) ----- 2kV
 - MM (Machine Model) ----- 200V

Recommended Operating Conditions (Note 4)

- Supply Input Voltage, VIN ----- 2.5V to 24V
- Junction Temperature Range ----- -40°C to 125°C
- Ambient Temperature Range ----- -40°C to 85°C

Electrical Characteristics

(VIN = 5V, TA = 25°C, unless otherwise specified)

Parameter	Symbol	Test Conditions	Min	Typ	Max	Unit	
VIN Quiescent Current	IVIN	PWM = COMP = 0V, not switching	--	3	--	mA	
	IVIN_SW	PWM = COMP = 2V, switching	--	4	--		
VIN Shutdown Current	ISHDN	VIN = 4.5V, EN = 0V	--	--	10	μA	
VIN Under Voltage Lockout Threshold	VUVLO	VIN rising	--	2.3	--	V	
		VIN falling	--	2.1	--		
PWM Dimming Frequency	fPWM		0.1	--	20	kHz	
Control Input							
EN, PWM Input Voltage	High	VIH	VIN = 2.5V to 24V	1.3	--	24	V
	Low	VIL	VIN = 2.5V to 24V	--	--	0.5	
Boost Converter							
Switching Frequency	fsw	RFSW = 22kΩ	0.8	1	1.2	MHz	
		RFSW = 51kΩ	0.4	0.5	0.6		
LX On Resistance (N-MOSFET)	RLX	VIN > 4.5V	0.18	0.2	0.22	Ω	

Parameter	Symbol	Test Conditions	Min	Typ	Max	Unit
Minimum On-Time	t _{ON(MIN)}	F _{SW} = 1MHz	40	60	80	ns
Maximum Duty	D _{MAX}	F _{SW} = 1MHz	90	93	96	%
LX Current Limit	I _{LIM}		2.2	2.5	2.8	A
Regulated V _{LEDx}	V _{LEDx}	Highest LED string, I _{LED} = 20mA	0.5	0.6	0.7	V
Low Dropout Linear Regulator						
LDO Output Voltage Range	V _{DC}		3.6	3.8	4	V
LED Current Programming						
Maximum LED Current	I _{FB(MAX)}	MODE = PWM Mode	5	--	50	mA
		MODE = Mixed Mode	8	--	50	
LED Current Accuracy	I _{LEDA}	2V > V _{LEDx} > 0.5V, R _{ISET} = 12kΩ	19.4	20	20.6	mA
LED Current Matching	I _{LEDM}	2V > V _{LEDx} > 0.5V, R _{ISET} = 12kΩ, Formulated by (I _{LEDx} - I _{AVG}) / I _{AVG} x 100%	--	--	2	%
ISET Pin Voltage	V _{ISET}		0.76	1	1.24	V
Fault Protection						
OVP Threshold	V _{OVP}		1.16	1.2	1.24	V
OVP UVLO Threshold	V _{OVPF}		--	50	--	mV
Thermal Shutdown Temperature	T _{SD}		--	150	--	°C
OTP Hysteresis	T _{OTP_Hys}		--	30	--	°C
LED Pin Under Voltage Threshold	V _{LSD}	Un-Connection	--	0.1	--	V

Note 1. Stresses beyond those listed “Absolute Maximum Ratings” may cause permanent damage to the device. These are stress ratings only, and functional operation of the device at these or any other conditions beyond those indicated in the operational sections of the specifications is not implied. Exposure to absolute maximum rating conditions may affect device reliability.

Note 2. θ_{JA} is measured under natural convection (still air) at T_A = 25°C with the component mounted on a high effective-thermal-conductivity four-layer test board on a JEDEC 51-7 thermal measurement standard. θ_{JC} is measured at the exposed pad of the package.

Note 3. Devices are ESD sensitive. Handling precaution is recommended.

Note 4. The device is not guaranteed to function outside its operating conditions.

Typical Application Circuit

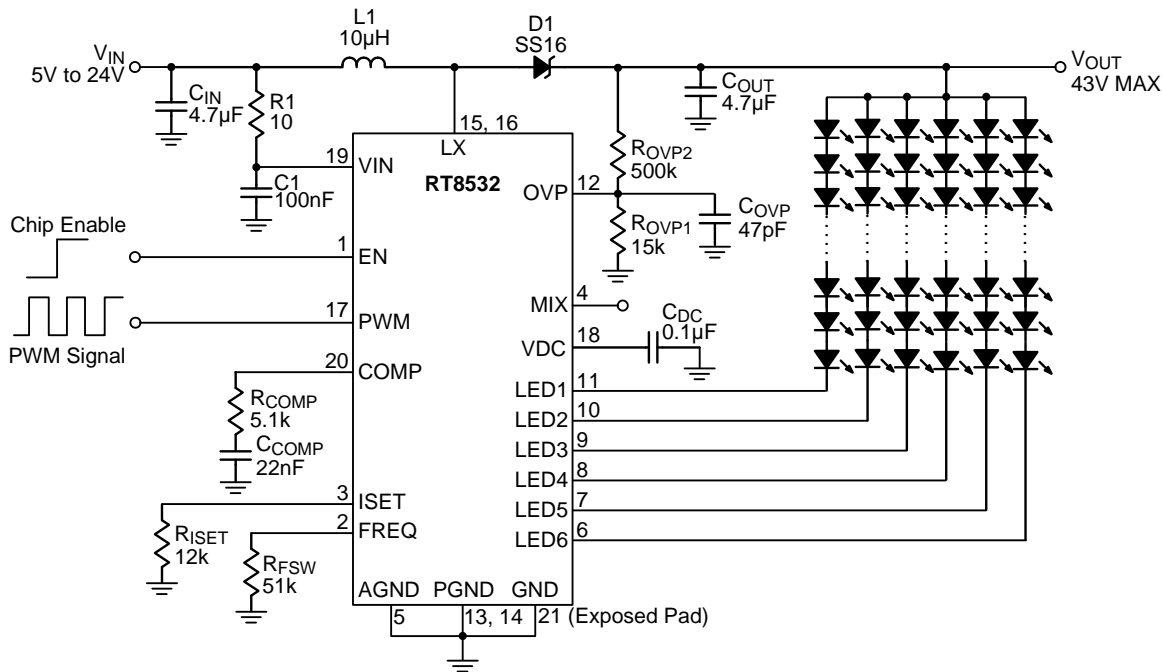

Figure 1. For General Application Circuit

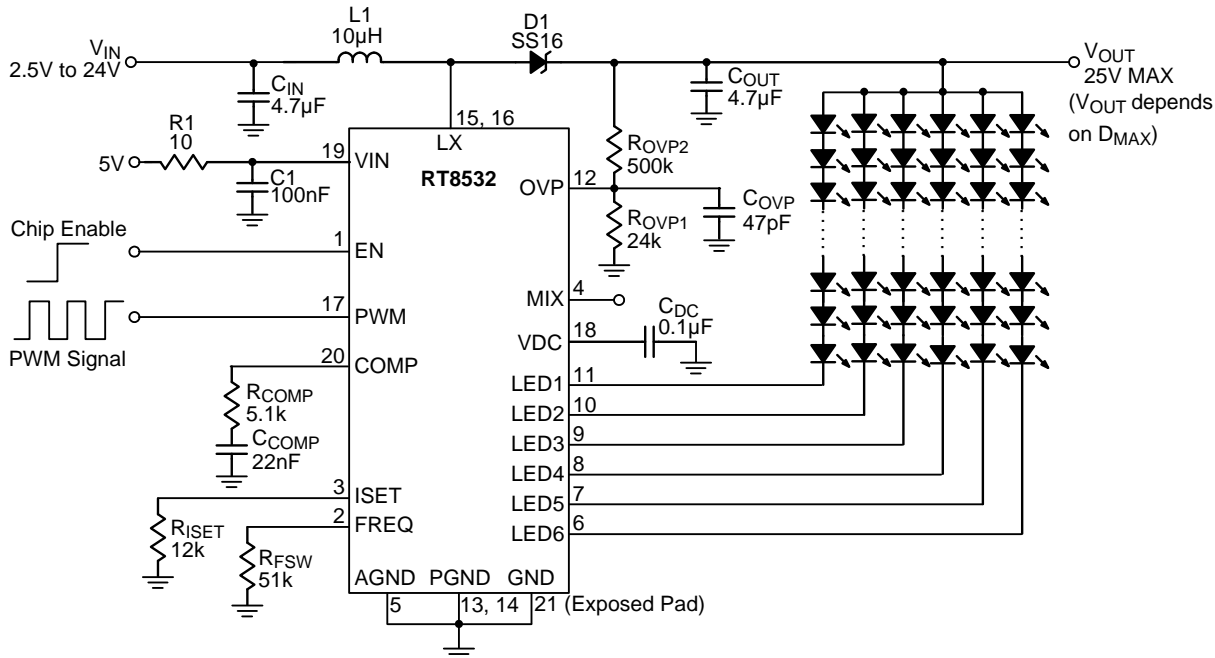
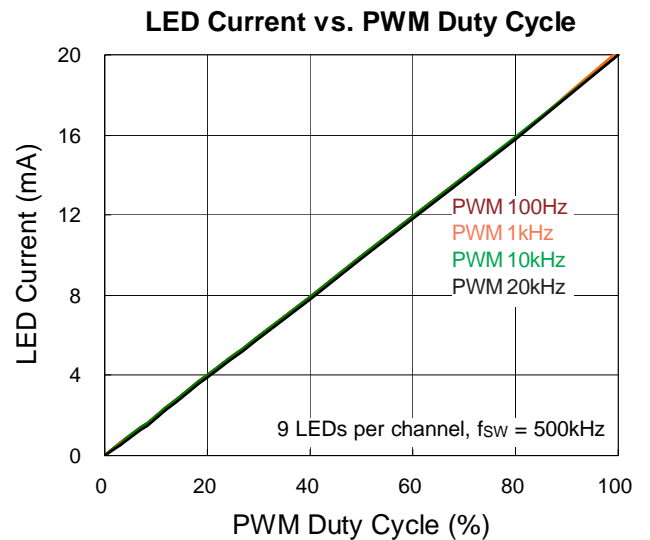
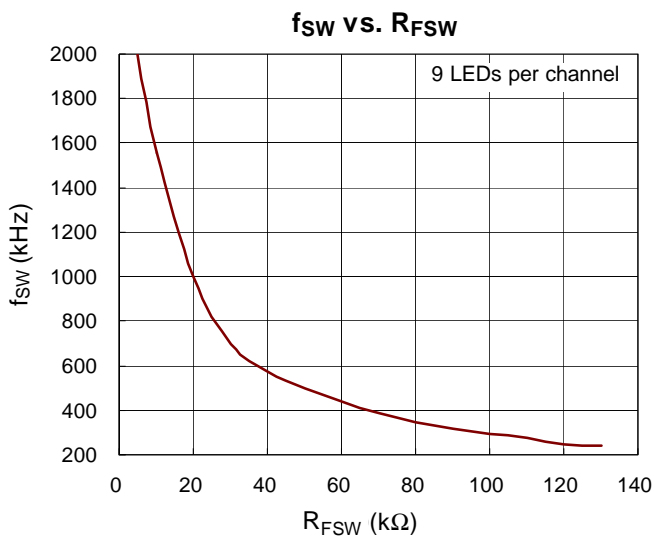
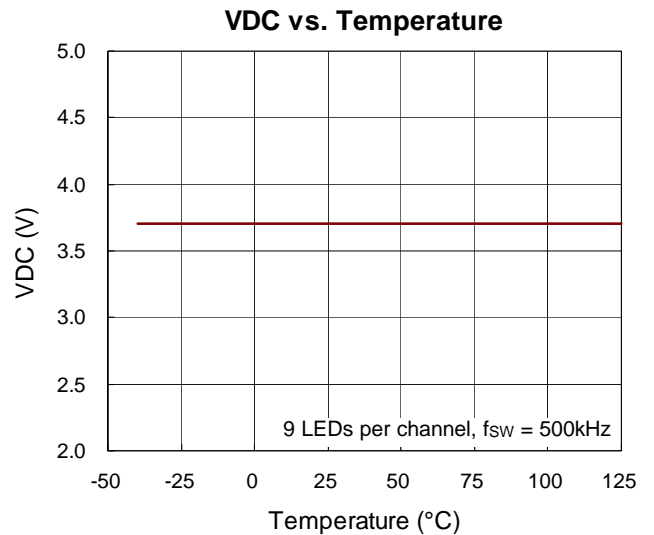
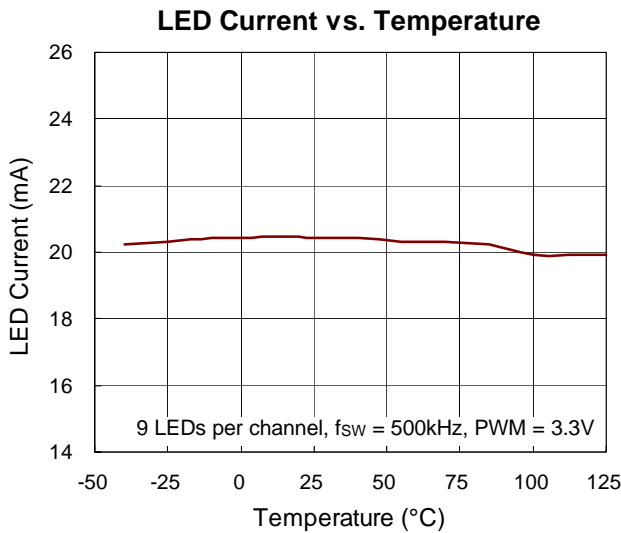
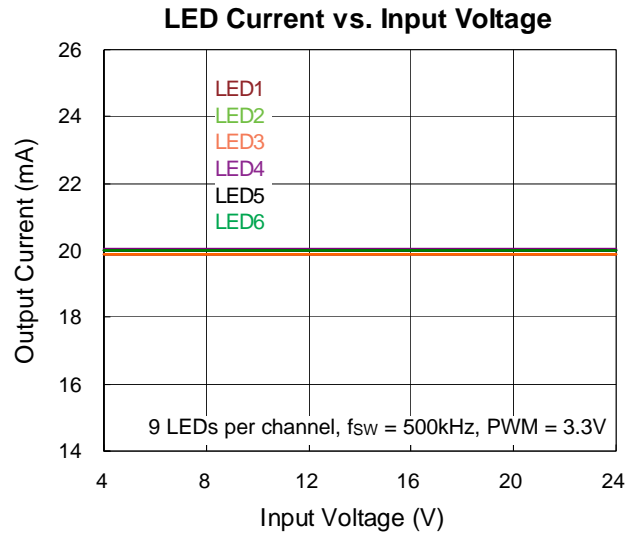
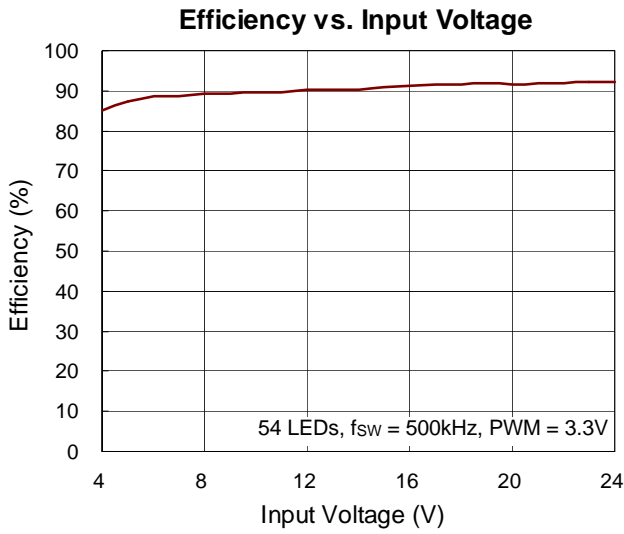
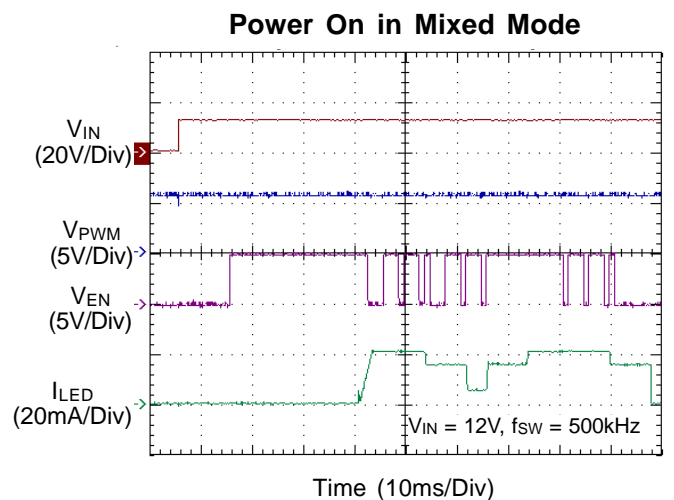
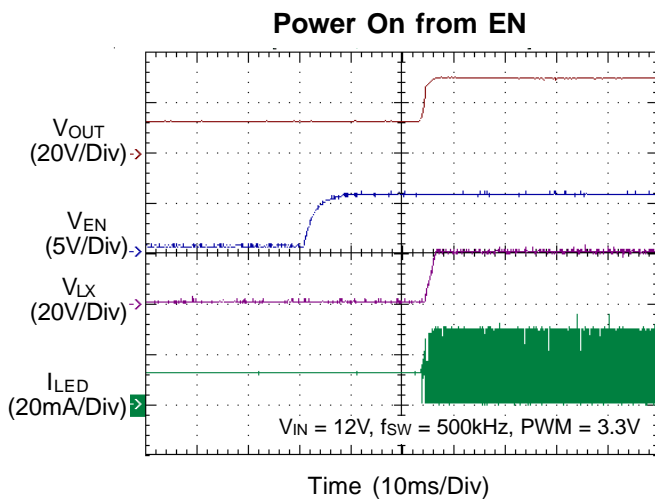
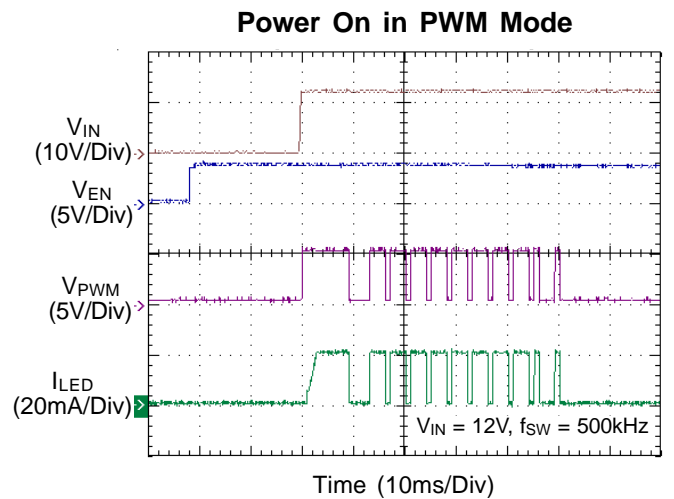
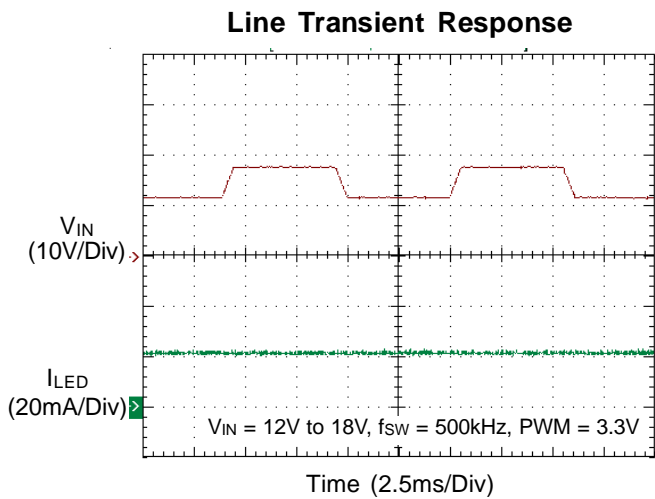
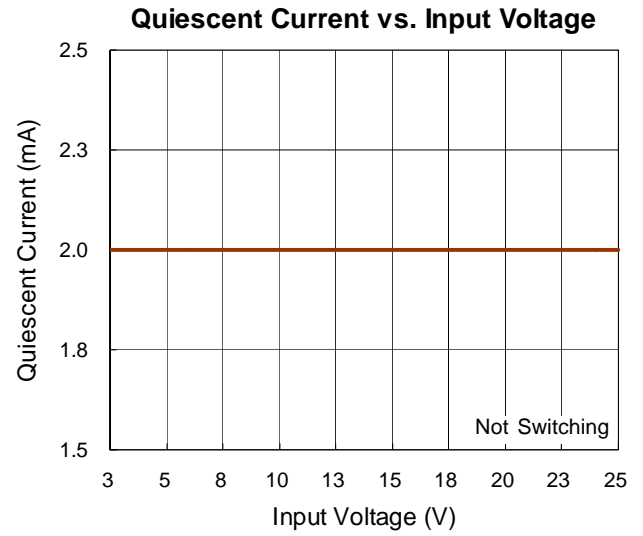
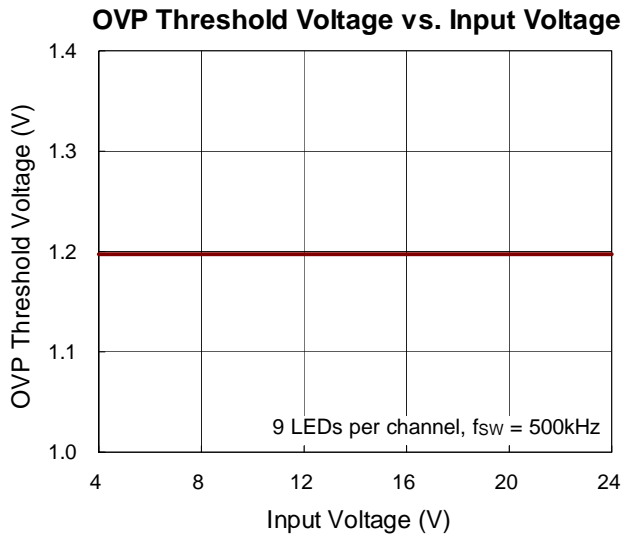

Figure 2. For Low Input Voltage Application Circuit

Typical Operating Characteristics





Application Information

The RT8532 is a general purpose 6-CH LED driver capable of delivering an adjustable 5mA to 50mA LED current. The IC is a current mode boost converter integrated with a 43V/2.5A power switch and can cover a wide VIN range from 2.5V to 24V. The part integrates both built-in soft-start and with PWM dimming control; moreover, it provides over voltage, over temperature and current limiting protection features. It also integrates PWM and mixed mode dimming function for accurate LED current control. The PWM dimming frequency can operate from 100Hz to 20kHz without inducing any inrush current in LED or inductor.

Input Capacitor Selection

Low ESR ceramic capacitors are recommended for input capacitor applications. Low ESR will effectively reduce the input ripple voltage caused by the switching operation. Two 2.2μF low ESR ceramic capacitors are sufficient for most applications. Nevertheless, this value can be decreased for applications with lower output current requirement. Another consideration is the voltage rating of the input capacitor, which must be greater than the maximum input voltage.

Output Capacitor Selection

Output ripple voltage is an important index for estimating chip performance. This portion consists of two parts. One is the product of the inductor current ripple with the ESR of the output capacitor, while the other part is formed by the charging and discharging process of the output capacitor. As shown in Figure 3, ΔVOUT1 can be evaluated based on the ideal energy equalization. According to the definition of Q, the Q value can be calculated as the following equation :

$$Q = \frac{1}{2} \times \left[\left(I_{IN} + \frac{1}{2} \Delta I_L - I_{OUT} \right) + \left(I_{IN} - \frac{1}{2} \Delta I_L - I_{OUT} \right) \right] \times \frac{V_{IN}}{V_{OUT}} \times \frac{1}{f_{SW}} = C_{OUT} \times \Delta V_{OUT1}$$

where f_{SW} is the switching frequency and ΔI_L is the inductor ripple current. Move C_{OUT} to the left side to estimate the value of ΔV_{OUT1} according to the following equation :

$$\Delta V_{OUT1} = \frac{D \times I_{OUT}}{\eta \times C_{OUT} \times f_{SW}}$$

Finally, taking ESR into account, the overall output ripple voltage can be determined by the following equation :

$$\Delta V_{OUT} = I_{IN} \times ESR + \frac{D \times I_{OUT}}{\eta \times C_{OUT} \times f_{SW}}$$

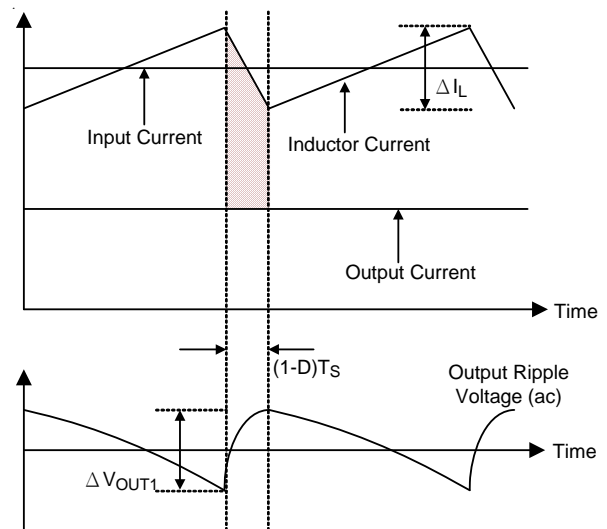

Figure 3. The Output Ripple Voltage without the Contribution of ESR

Inductor Selection

The inductor value depends on the maximum input current. As a general rule the inductor ripple current is 20% to 40% of maximum input current. If 40% is selected as an example, the inductor ripple current can be calculated according to the following equation :

$$I_{IN(MAX)} = \frac{V_{OUT} \times I_{OUT(MAX)}}{\eta \times V_{IN}}$$

$$I_{RIPPLE} = 0.4 \times I_{IN(MAX)}$$

where η is the efficiency of the boost converter, $I_{IN(MAX)}$ is the maximum input current and I_{RIPPLE} is the inductor ripple current. The input peak current can be obtained by adding the maximum input current with half of the inductor ripple current as shown in the following equation :

$$I_{PEAK} = 1.2 \times I_{IN(MAX)}$$

Note that the saturated current of inductor must be greater than I_{PEAK} . The inductance can eventually be determined according to the following equation :

$$L1 = \frac{\eta \times (V_{IN})^2 \times D \times (V_{OUT} - V_{IN})}{0.4 \times (V_{OUT})^2 \times I_{OUT} \times f_{SW}}$$

where V_{OUT} is the maximum output voltage, V_{IN} is the minimum input voltage, f_{SW} is the switching frequency, and I_{OUT} is the sum of current from all LED strings.

LED Soft-Start Function

The soft-start time of the LED boost converter, defined as the period from EN to set I_{OUT} , is several tens of milliseconds according to the difference of PWM or Mixed mode. The LED starts up after V_{IN} , PWM and EN signals are all ready. The soft-start inrush peak current must be less than 2.5A.

LED Driver Compensation

The control loop can be compensated by adjusting the external components connected to the COMP pin. The COMP pin is the output of the internal error amplifier. The compensation capacitors, C_C and C_{COMP} , will adjust the integrator zero and pole respectively to maintain stability. Moreover, the resistor, R_{COMP} , will adjust the mid-band gain for fast transient response.

Diode Selection

Schottky diodes D1 are recommended for most applications because of their fast recovery time and low forward voltage. Power dissipation, reverse voltage rating, and pulsating peak current are important parameters for consideration when making a Schottky diode selection. Make sure that the diode's peak current rating exceeds I_{PEAK} and reverse voltage rating exceeds the maximum output voltage.

Setting and Regulation of LED Current

The LED current can be calculated by the following equation :

$$I_{LED} (mA) = \frac{240}{R_{ISET} (k\Omega)}$$

where R_{ISET} is the resistor between the ISET pin and GND. This setting is the reference for the LED current at LED1 to LED6 and represents the sensed LED current for each string. The DC/DC converter regulates the LED current according to the setting.

PWM Mode and Mixed Mode Brightness Dimming

The RT8532 allows two ways of controlling the LED brightness.

PWM Mode Dimming : When the MIX pin is connected to GND, the dimming mode operates in PWM Mode. During the PWM dimming, the current source turn-on/off is synchronized with the PWM signal. The LED current frequency is equivalent to PWM input frequency.

Mixed Mode Dimming : If the MIX pin is floating or tied to VDC, the dimming mode operates in Mixed Mode. In this mode the PWM and I_{LED} dimming cycle will delay by 2 periods. First cycle delay is required for the period, while the second cycle delay is for the duty rate calculation.

(a) When $25\% \leq \text{PWM duty} \leq 100\%$, the current source outputs are DC dimming, and the PWM duty cycle modulates the amplitude of the currents.

(b) When $\text{PWM Duty} < 25\%$, the DC dimming will translate to DC-PWM dimming to control the LED current. In this state, the LED current is fixed at $0.25 \times I_{SET}$, and the dimming duty is $4 \times \text{PWM duties}$. The minimum D/A Converter is 512 steps resolution for I_{LED} regulation.

Brightness Control

The RT8532 features the digital dimming control scheme. A very high contrast ratio true digital PWM dimming can be achieved by driving PWM pin with a PWM signal and the recommended PWM frequency is 100Hz to 10kHz. Dimming frequency can be sufficiently adjusted from 100Hz to 20kHz. However, LED current cannot be 100% proportional to duty cycle especially for high frequency and low duty ratio because of physical limitation caused by inductor rising time. Please refer to Table 1 and Table2.

Table 1. Mixed Dimming Mode

Dimming Frequency (Hz)	Duty (Min)	Duty (Max)
100 < f _{PWM} ≤ 200	0.18%	100%
200 < f _{PWM} ≤ 500	0.18%	100%
500 < f _{PWM} ≤ 1k	0.2%	100%
1k < f _{PWM} ≤ 2k	0.2%	100%
2k < f _{PWM} ≤ 5k	0.3%	100%
5k < f _{PWM} ≤ 10k	0.3%	100%
10k < f _{PWM} ≤ 20k	0.6%	100%

Table 2. PWM Dimming Mode

Dimming Frequency (Hz)	Duty (Min)	Duty (Max)
100 < f _{PWM} ≤ 200	0.02%	100%
200 < f _{PWM} ≤ 500	0.02%	100%
500 < f _{PWM} ≤ 1k	0.04%	100%
1k < f _{PWM} ≤ 2k	0.06%	100%
2k < f _{PWM} ≤ 5k	0.15%	100%
5k < f _{PWM} ≤ 10k	0.3%	100%
10k < f _{PWM} ≤ 20k	0.6%	100%

Note : The minimum duty in Table 1 and Table 2 is based on the application circuit and does not consider the deviation of current linearity when f_{PWM} > 10kHz, ILED may not achieve setting current in duty (min.) due to different V_{OUT} / V_{IN} ratio at V_{IN} = 12V.

Over Temperature Protection

The RT8532 includes an Over Temperature Protection (OTP) feature to prevent overheating due to excessive power dissipation from damaging the device. The OTP function will shut down LED driver when the junction temperature exceeds 150°C. It will reactivate the device when powered on again. To maintain continuous operation, the junction temperature should be kept below 125°C.

LED Driver Over Voltage Protection

The LED driver equips an Over Voltage Protection (OVP) function. When the voltage at the OVP pin reaches a threshold of approximately 1.2V, the driver will turn off. The drivers turn on again once the voltage at OVP drops below the threshold voltage. Thus, the output voltage can be clamped at a certain voltage level. This voltage level can be calculated by the following equation :

$$V_{OUT, OVP} = V_{OVP} \times \left(1 + \frac{R_{OVP2}}{R_{OVP1}} \right)$$

where R_{OVP1} and R_{OVP2} are the resistors in the voltage divider connected to the OVP pin. It is suggested to use 500kΩ for R_{OVP2} to reduce loading effect.

LED Channel Open Circuit Protection

If at least one channel is in normal operation, the LED driver will automatically ignore the open channels and continue to regulate current for the channels in normal operation.

Under Voltage Lockout (UVLO)

The UVLO circuit compares the LED driver input voltage at V_{IN} with the UVLO threshold to ensure the input voltage is high enough for reliable operation. The 200mV (typ.) hysteresis prevents supply transients from causing a shutdown. Once V_{IN} exceeds the UVLO rising threshold, the LED soft-start will begin after a several ms delay. When V_{IN} falls below the UVLO falling threshold, the controller turns off all LED driver functions.

Thermal Considerations

The junction temperature should never exceed the absolute maximum junction temperature $T_{J(MAX)}$, listed under Absolute Maximum Ratings, to avoid permanent damage to the device. The maximum allowable power dissipation depends on the thermal resistance of the IC package, the PCB layout, the rate of surrounding airflow, and the difference between the junction and ambient temperatures. The maximum power dissipation can be calculated using the following formula :

$$P_{D(MAX)} = (T_{J(MAX)} - T_A) / \theta_{JA}$$

where $T_{J(MAX)}$ is the maximum junction temperature, T_A is the ambient temperature, and θ_{JA} is the junction-to-ambient thermal resistance.

For continuous operation, the maximum operating junction temperature indicated under Recommended Operating Conditions is 125°C. The junction-to-ambient thermal resistance, θ_{JA} , is highly package dependent. For a WQFN-20L 3x3, the thermal resistance, θ_{JA} , is 68°C/W on a standard JEDEC 51-7 high effective-thermal-conductivity four-layer test board. The maximum power dissipation at $T_A = 25^\circ\text{C}$ can be calculated as below :

$$P_{D(MAX)} = (125^\circ\text{C} - 25^\circ\text{C}) / (68^\circ\text{C/W}) = 1.471\text{W for a WQFN-20L 3x3 package.}$$

The maximum power dissipation depends on the operating ambient temperature for the fixed $T_{J(MAX)}$ and the thermal resistance, θ_{JA} . The derating curves in Figure 4 allows the designer to see the effect of rising ambient temperature on the maximum power dissipation.

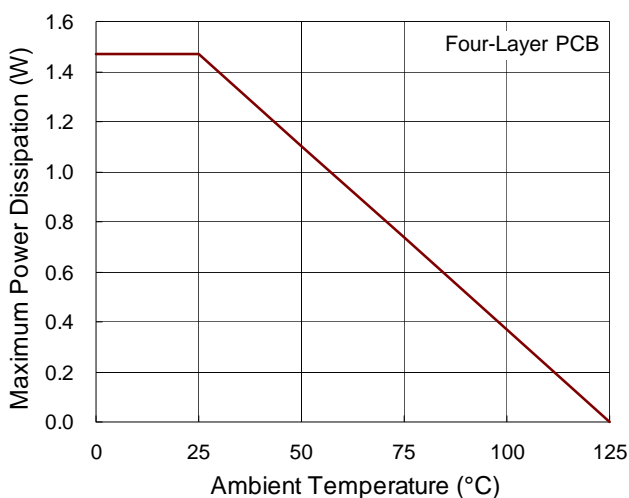

Figure 4. Derating Curve of Maximum Power Dissipation

Layout Considerations

PCB layout is very important to design power switching converter circuits. The following layout guide lines should be strictly followed for best performance of the RT8532.

- ▶ The power components L1, D1, C_{IN} and C_{OUT} must be placed as close as possible to reduce the ac current loop. The PCB trace between power components must be short and wide as possible due to large current flow through these trace during operation.
- ▶ Place L1 and D1 as close to LX pins as possible. The trace should be short and wide as possible.
- ▶ Place the input capacitor C1 close to VIN pin.
- ▶ Pin 20 is the compensation point to adjust system stability. Place the compensation components to pin 20 as close as possible.

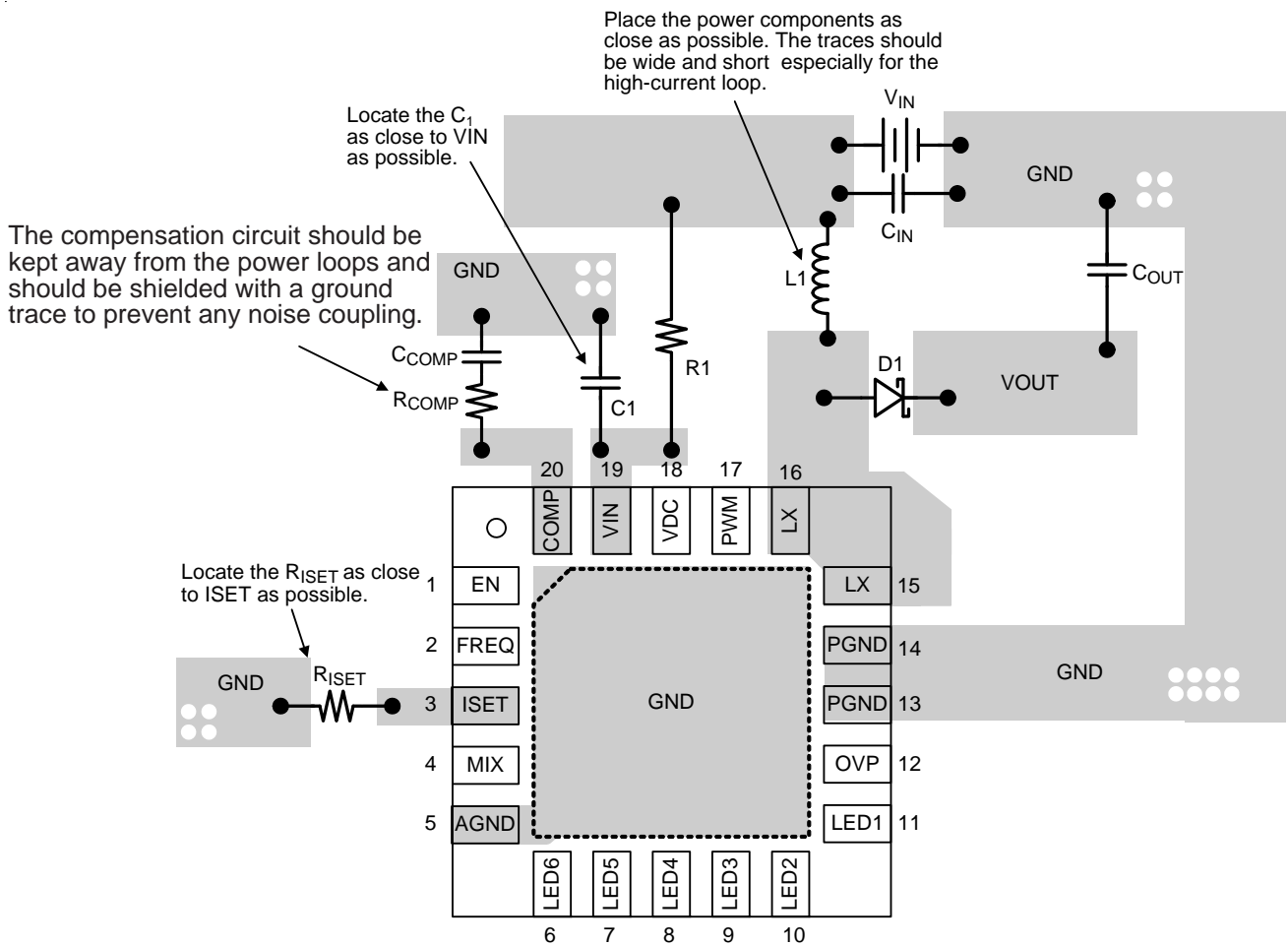
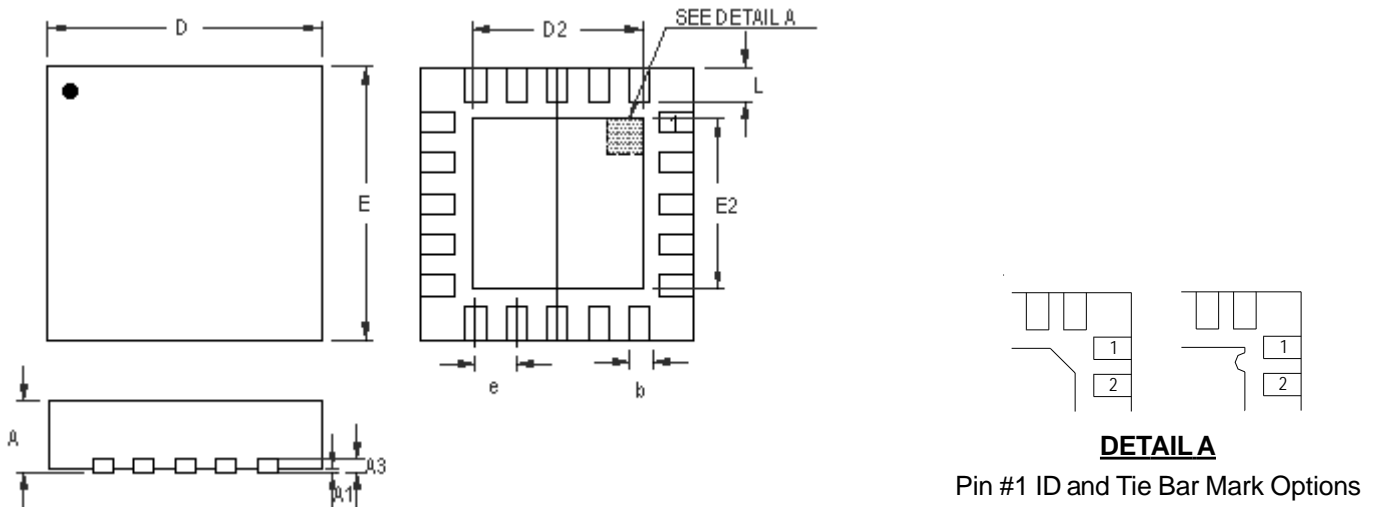

Figure 5. PCB Layout Guide

Outline Dimension



Note : The configuration of the Pin #1 identifier is optional, but must be located within the zone indicated.

Symbol	Dimensions In Millimeters		Dimensions In Inches	
	Min	Max	Min	Max
A	0.700	0.800	0.028	0.031
A1	0.000	0.050	0.000	0.002
A3	0.175	0.250	0.007	0.010
b	0.150	0.250	0.006	0.010
D	2.900	3.100	0.114	0.122
D2	1.650	1.750	0.065	0.069
E	2.900	3.100	0.114	0.122
E2	1.650	1.750	0.065	0.069
e	0.400		0.016	
L	0.350	0.450	0.014	0.018

W-Type 20L QFN 3x3 Package



Richtek Technology Corporation

14F, No. 8, Tai Yuen 1st Street, Chupei City
 Hsinchu, Taiwan, R.O.C.
 Tel: (8863)5526789

Richtek products are sold by description only. Richtek reserves the right to change the circuitry and/or specifications without notice at any time. Customers should obtain the latest relevant information and data sheets before placing orders and should verify that such information is current and complete. Richtek cannot assume responsibility for use of any circuitry other than circuitry entirely embodied in a Richtek product. Information furnished by Richtek is believed to be accurate and reliable. However, no responsibility is assumed by Richtek or its subsidiaries for its use; nor for any infringements of patents or other rights of third parties which may result from its use. No license is granted by implication or otherwise under any patent or patent rights of Richtek or its subsidiaries.

Looking for pricing, stock, or lifecycle information?

Click below to explore more details on WIN SOURCE:

-  [View RT8532GQW on WIN SOURCE](#)
-  [Richtek USA Inc. Information](#)

Optimize Your Supply Chain with WIN SOURCE Solutions

-  Global Sourcing Solution
-  Obsolete Management
-  Cost Control Management
-  Shortage Management
-  Alternative Solution
-  Excess Inventory Management