



**THE DATASHEET OF
RT8475ZS**



High Voltage High Current LED Driver Controller for Buck, Boost or Buck-Boost Topology

General Description

The RT8475 is a current mode PWM controller designed to drive an external MOSFET for high current LED applications. With a current sense amplifier threshold of 190mV, the LED current is programmable with one external current sense resistor. With the maximum operating input voltage of 36V and output voltage up to 90V, the RT8475 is ideal for buck, boost or buck-boost operation.

With the switching frequency programmable over 100kHz to 1MHz, the external inductor and capacitors can be small while maintaining high efficiency.

Dimming can be done by either analog or digital. The built-in clamping comparator and filter allow easy low noise analog dimming conversion from digital signal with only one external capacitor.

The RT8475 is available in SOP-14 and WQFN-16L 3x3 packages.

Ordering Information

RT8475 □ □

- Package Type
 - S : SOP-14
 - QW : WQFN-16L 3x3 (W-Type)
- Lead Plating System
 - G : Green (Halogen Free and Pb Free) (For SOP-14 package only)
 - Z : ECO (Ecological Element with Halogen Free and Pb free)

Note :

Richtek products are :

- ▶ RoHS compliant and compatible with the current requirements of IPC/JEDEC J-STD-020.
- ▶ Suitable for use in SnPb or Pb-free soldering processes.

Features

- High Voltage Capability : V_{IN} Up to 36V, LED Sensing Threshold Common Mode Voltage Up to 90V
- Buck, Boost or Buck-Boost Operation
- Programmable Switching Frequency
- Easy Dimming Control : Analog or Digital Converting to Analog with One External Capacitor
- Programmable Soft-Start to Avoid Inrush Current
- Programmable Over Voltage Protection
- V_{IN} Under Voltage Lockout and Thermal Shutdown
- RoHS Compliant and Halogen Free

Applications

- General Industrial High Power LED Lighting
- Desk Lights and Room Lighting
- Building and Street Lighting
- Industrial Display Backlight

Pin Configuration

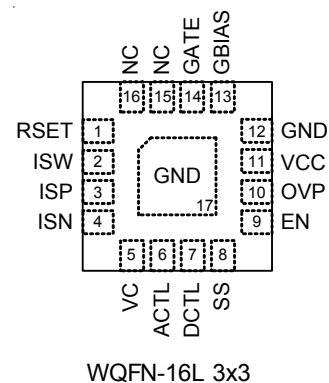
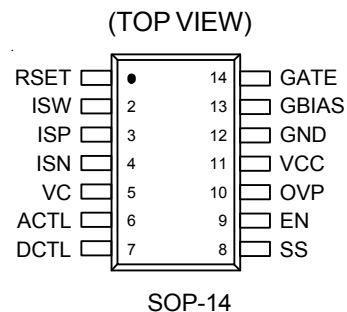

Marking Information

RT8475GS

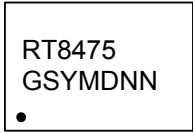

RT8475GS : Product Number
YMDNN : Date Code

RT8475ZQW

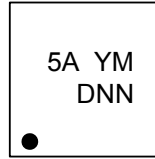

5A : Product Code
YMDNN : Date Code

RT8475ZS

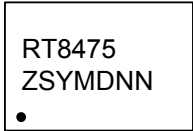

RT8475ZS : Product Number
YMDNN : Date Code

Typical Application Circuit

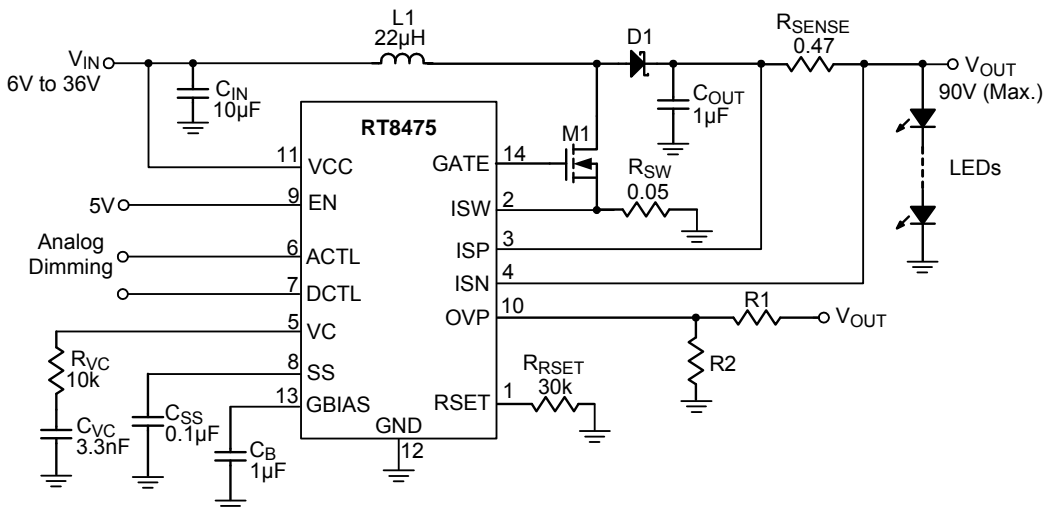

Figure 1. Analog Dimming in Boost Configuration

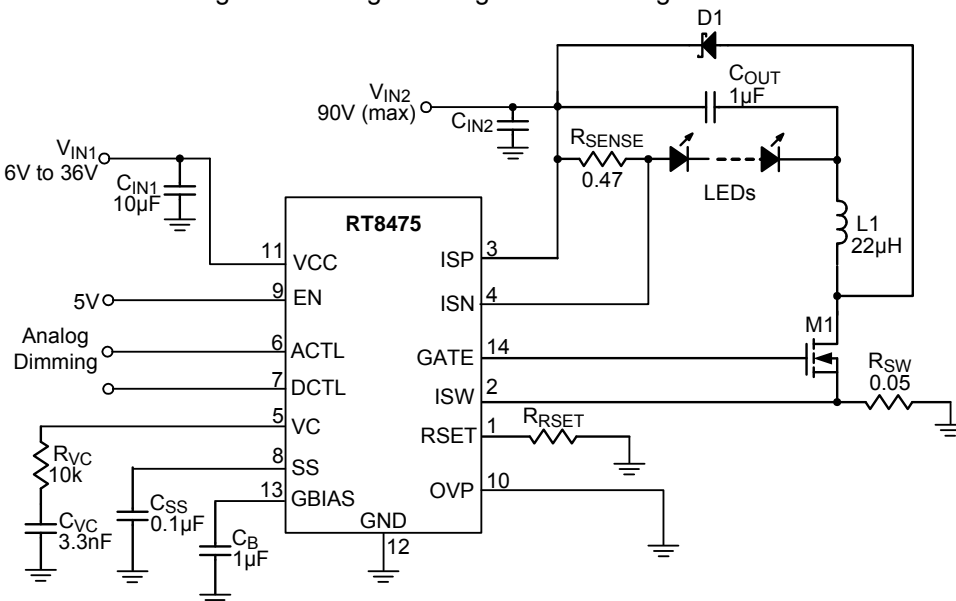

Figure 2. Analog Dimming in Buck Configuration

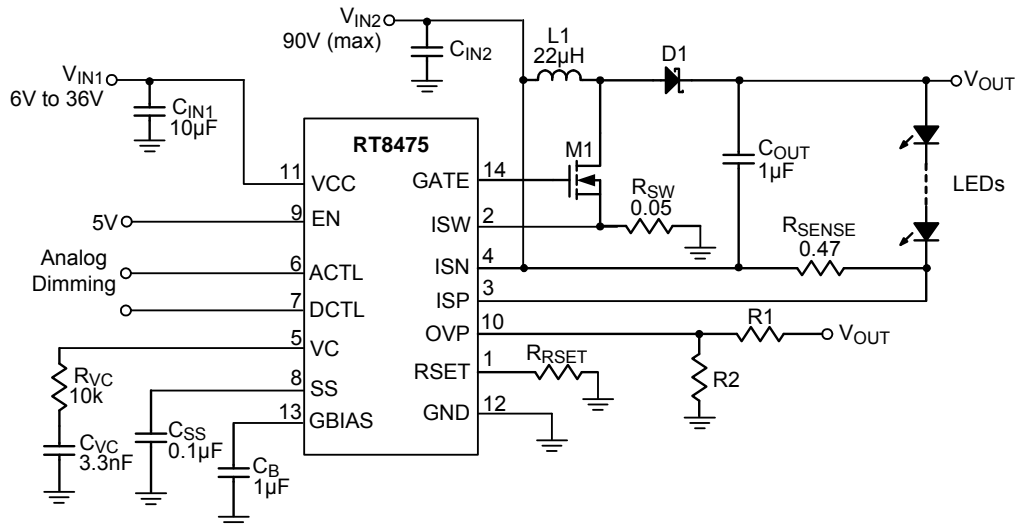

Figure 3. Analog Dimming in Buck-Boost Configuration

Functional Pin Description

Pin No.		Pin Name	Pin Function
SOP-14	WQFN-16L 3x3		
1	1	RSET	Switch frequency set pin. Connect a resistor from RSET to GND. $RRSET = 30k\Omega$ will set $fsw = 350kHz$.
2	2	ISW	External MOSFET Switch Current Sense. Connect the current sense resistor between external N-MOSFET switch and the ground.
3	3	ISP	LED current sense amplifier positive input with common mode up to 90V.
4	4	ISN	LED current sense amplifier negative input. Voltage threshold between ISP and ISN is 190mV with common mode voltage up to 90V.
5	5	VC	PWM control loop compensation.
6	6	ACTL	Analog dimming control. The effective programming voltage range of the pin is between 0.2V and 1.2V.
7	7	DCTL	By adding a $0.47\mu F$ filtering capacitor on ACTL pin, the PWM dimming signal on DCTL pin can be averaged and converted into analog dimming signal on the ACTL pin.
8	8	SS	Soft-start. A capacitor of at least 10nF is required for proper soft-start.
9	9	EN	Chip enable (active high). When this pin voltage is low, the chip is in shutdown mode.
10	10	OVP	Over voltage protection. The PWM converter turns off when the voltage of the pin goes to higher than 1.18V.
11	11	VCC	Power supply pin of the chip. For good bypass, a low ESR capacitor is required.
12	12, 17 (Exposed Pad)	GND	Ground. The Exposed Pad must be Soldered to a Large PCB and Connected to GND for Maximum Power Dissipation.
13	13	GBIAS	Internal gate driver bias. A good bypass capacitor is required.
14	14	GATE	External MOSFET switch gate driver output.
--	15, 16	NC	No internal connection.

Functional Block Diagram

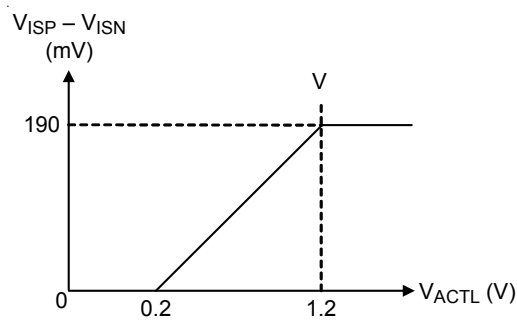
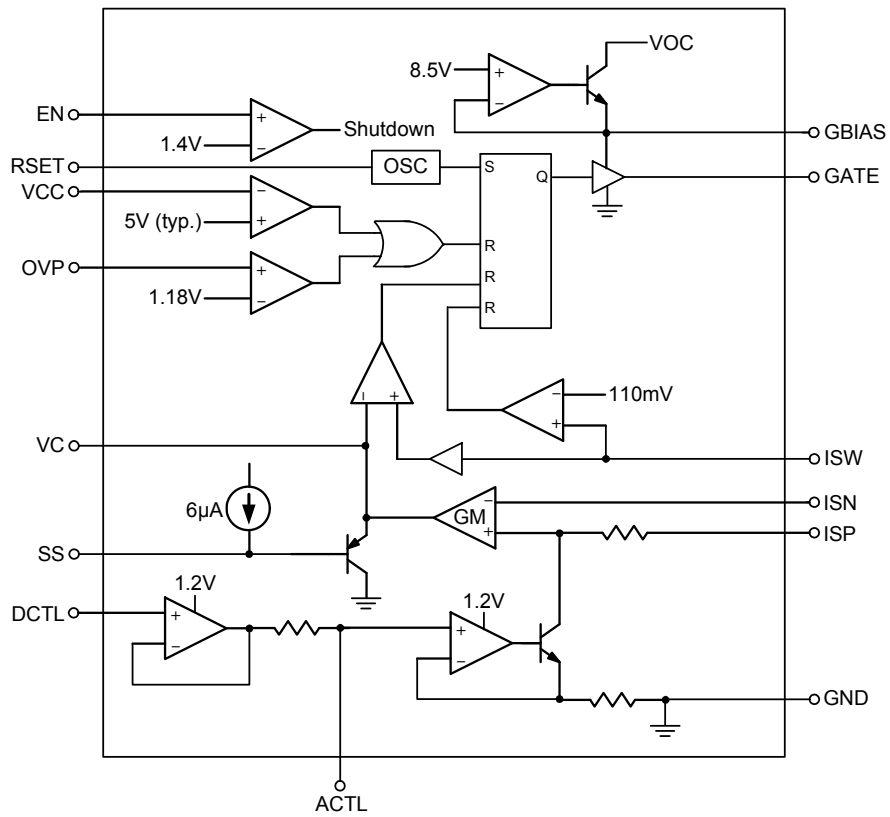

Figure 4

Absolute Maximum Ratings (Note 1)

- Supply Input Voltage, VCC ----- -0.3 to 38V
- GBIAS, GATE ----- -0.3 to 10V
- ISW ----- -0.3 to 1V
- ISP, ISN ----- -0.3 to 100V
- DCTL, ACTL, OVP (Note 2) ----- -0.3 to 8V
- EN ----- -0.3 to 20V
- SS, RSET, VC ----- -0.3 to 5V
- Power Dissipation, P_D @ T_A = 25°C
 - SOP-14 ----- 1.0W
 - WQFN-16L 3x3 ----- 1.471W
- Package Thermal Resistance (Note 3)
 - SOP-14, θ_{JA} ----- 100°C/W
 - WQFN-16L 3x3, θ_{JA} ----- 68°C/W
 - WQFN-16L 3x3, θ_{JC} ----- 7.5°C/W
- Junction Temperature ----- 150°C
- Lead Temperature (Soldering, 10 sec.) ----- 260°C
- Storage Temperature Range ----- -65°C to 150°C
- ESD Susceptibility (Note 4)
 - HBM (Human Body Model) ----- 2kV
 - MM (Machine Model) ----- 200V

Recommended Operating Conditions (Note 5)

- Supply Input Voltage Range, VCC ----- 6V to 36V
- Junction Temperature Range ----- -40°C to 125°C

Electrical Characteristics

(V_{CC} = 24V, No Load on any Output, T_A = 25°C, unless otherwise specified)

Parameter		Symbol	Test Conditions	Min	Typ	Max	Unit
Overall							
Supply Current		I _{VCC}	V _{VC} ≤ 0.4V (Switching off)	--	6	7.2	mA
Shutdown Current		I _{SHDN}	V _{EN} ≤ 0.7V	--	12	--	μA
EN Threshold Voltage	Logic-High	V _{IH}		2	--	--	V
	Logic-Low	V _{IL}		--	--	0.5	
EN Input Current			V _{EN} ≤ 3V	--	--	1.2	μA
Current Sense Amplifier							
Input Threshold (V _{ISP} – V _{ISN})			V _{ACTL} ≥ 1.25V, 12V ≤ common mode ≤ 90V	182	190	198	mV
			1.25V ≥ V _{ACTL} ≥ 1.2V, (Note 7) 12V ≤ common mode ≤ 90V	--	188	--	
ISP Input Current		I _{ISP}	6V ≤ V _{ISP} ≤ 90V	--	140	--	μA
ISN Input Current		I _{ISN}	6V ≤ V _{ISN} ≤ 90V	--	60	--	μA
VC Output Current		I _{VC}	0.5V ≤ V _C ≤ 2.4V	--	±20	--	μA
VC Threshold for PWM Switch Off				--	0.7	--	V

Parameter	Symbol	Test Conditions	Min	Typ	Max	Unit
LED Dimming						
Analog Dimming ACTL Pin Input Current	I _{ACTL}	V _{ACTL} = 1.2V	--	1	--	μA
		V _{ACTL} = 0.2V	--	10	--	
LED Current On Threshold at ACTL	V _{ACTL_On}		--	1.3	--	V
LED Current Off Threshold at ACTL	V _{ACTL_Off}		--	0.2	--	V
DCTL Input Current	I _{DCTL}	0.3V ≤ V _{DCTL} ≤ 5V	--	--	0.5	μA
DCTL Threshold Voltage	V _{DCTL_H}	(Note 6)	2	--	--	V
	V _{DCTL_L}	(Note 6)	--	--	0.3	
PWM Control						
Switching Frequency	f _{SW}	R _{RSET} = 30kΩ	280	350	420	kHz
Minimum Off-Time		R _{RSET} = 30kΩ	--	250	--	ns
Switch Gate Driver						
GBIAS Voltage	V _{GBIAS}	I _{GBIAS} = 20mA	7.8	8.5	9.2	V
GATE Voltage High	V _{GATE_H}	I _{GATE} = -50mA	6	7.2	7.8	V
		I _{GATE} = -100μA	7.5	7.8	7.9	
GATE Voltage Low	V _{GATE_L}	I _{GATE} = 50mA	--	0.5	1	V
		I _{GATE} = 100μA	--	0.1	0.9	
GATE Drive Rise and Fall Time		1nF Load at GATE	--	20	100	ns
PWM Switch Current Limit Threshold	I _{SW_LIM}		80	110	145	mV
OVP and Soft-Start						
OVP Threshold	V _{OVP_th}		--	1.18	--	V
OVP Input Current	I _{OVP}	0.7V ≤ V _{OVP} ≤ 1.5V	--	--	0.1	μA
Soft-Start Pin Current	I _{SS}	V _{SS} ≤ 2V	--	6	--	μA
Thermal Shutdown Protection	T _{SD}		--	145	--	°C
Thermal Shutdown Hysteresis	ΔT _{SD}		--	10	--	

Note 1. Stresses beyond those listed under “Absolute Maximum Ratings” may cause permanent damage to the device. These are stress ratings only, and functional operation of the device at these or any other conditions beyond those indicated in the operational sections of the specifications is not implied. Exposure to absolute maximum rating conditions may affect device reliability.

Note 2. If connected with a 20kΩ serial resistor, ACTL and DCTL can go up to 36V.

Note 3. For WQFN-16L 3x3, θ_{JA} is measured in natural convection at T_A = 25°C on a high-effective thermal conductivity test board of JEDEC 51-7 thermal measurement standard. The measurement case position of θ_{JC} is on the exposed pad of the package. For SOP-14, θ_{JA} is measured in natural convection at T_A = 25°C on a low-effective thermal conductivity test board of JEDEC 51-3 thermal measurement standard.

Note 4. Devices are ESD sensitive. Handling precaution is recommended.

Note 5. The device is not guaranteed to function outside its operating conditions.

Note 6. Guaranteed by design, not subjected to production test.

Note 7. The ACTL dimming curve is saturating when V_{ACTL} ≥ 1.2V. Please refer to typical operation characteristics curve of I_{LED} vs. V_{ACTL}. This item is not subjected to production test.

Typical Operating Characteristics

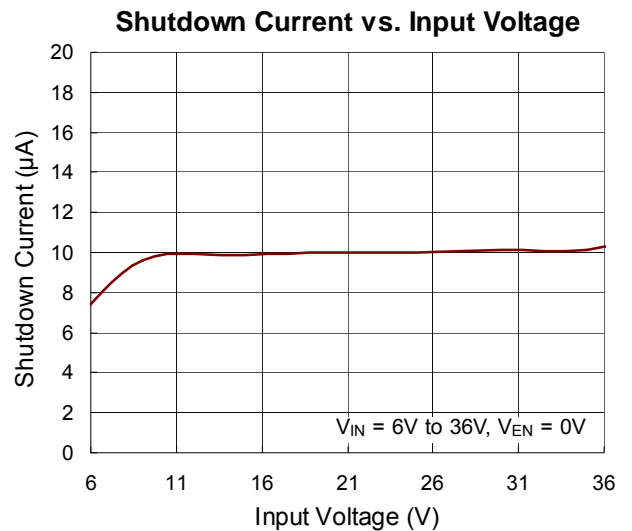
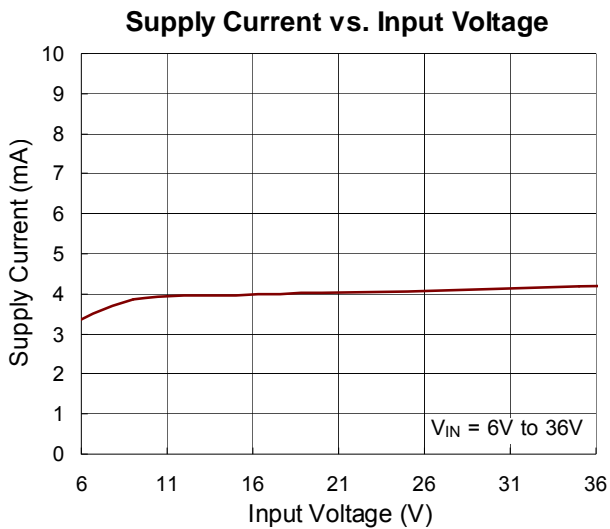
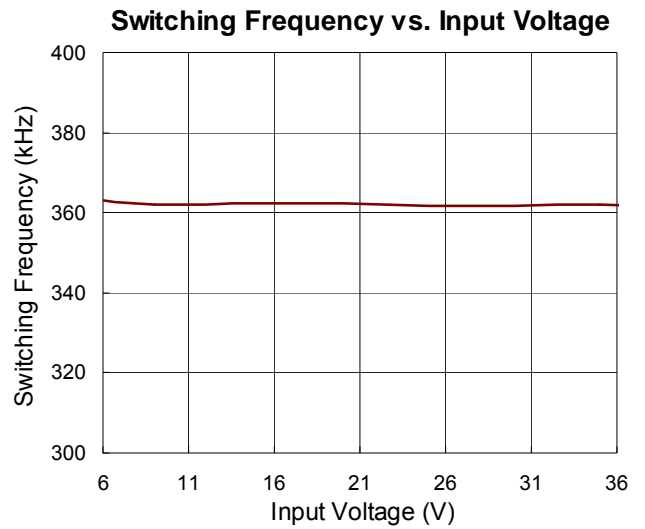
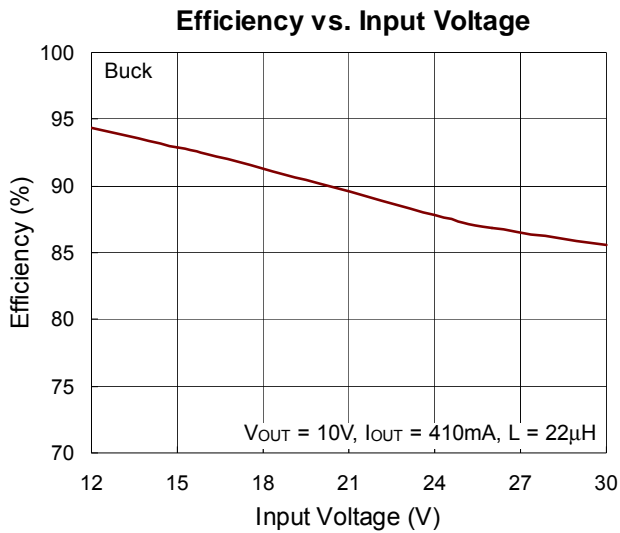
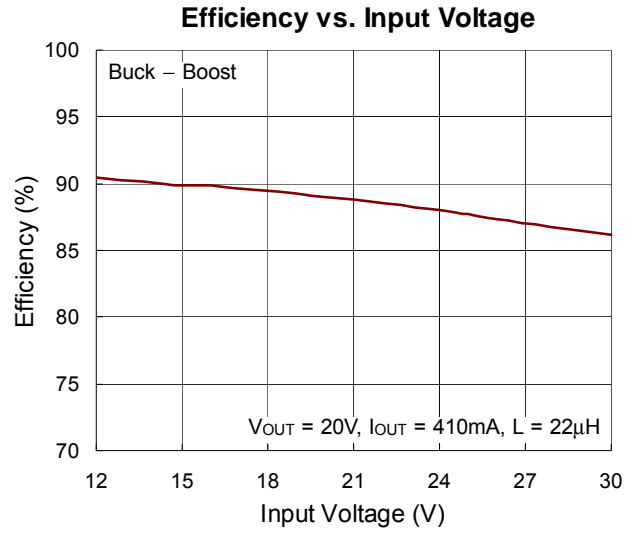
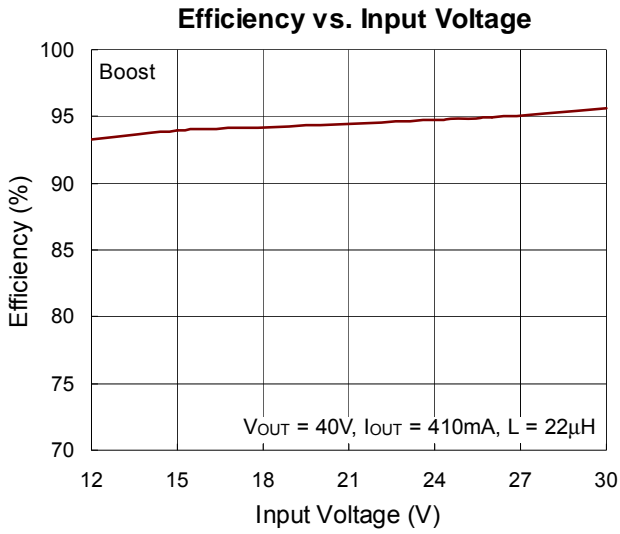

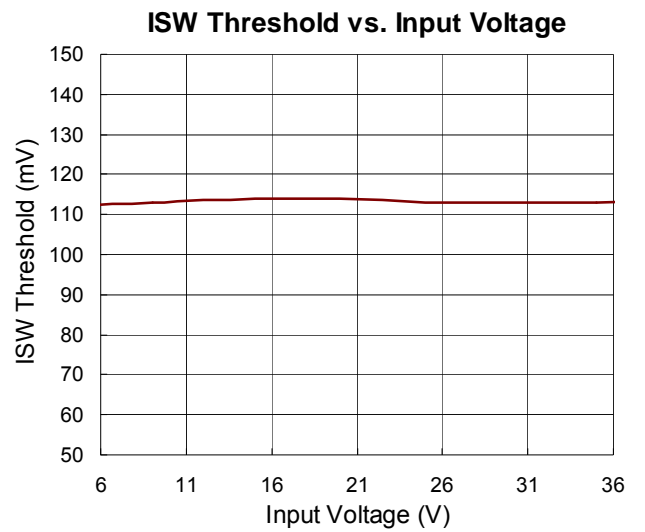
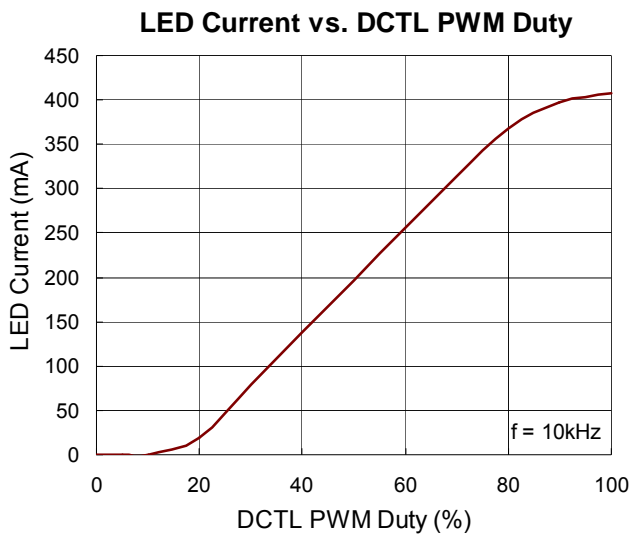
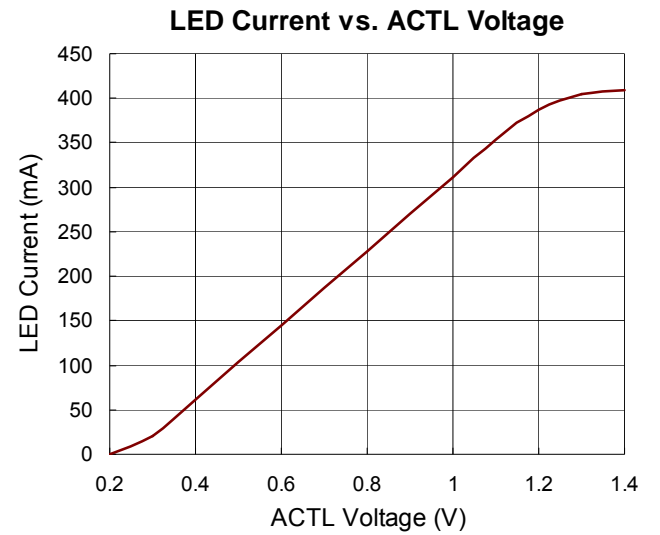
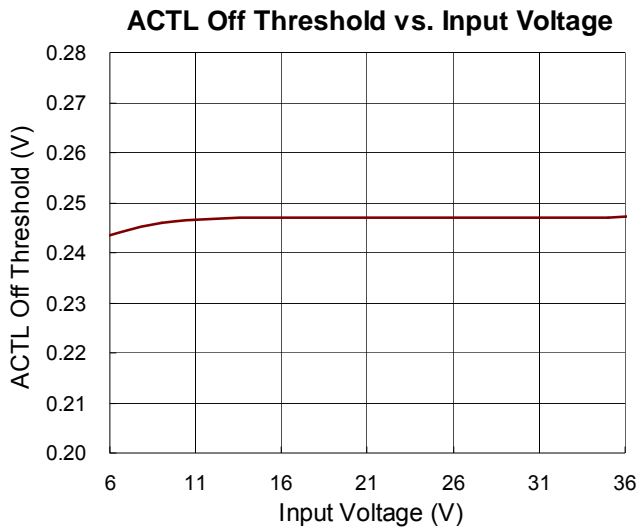
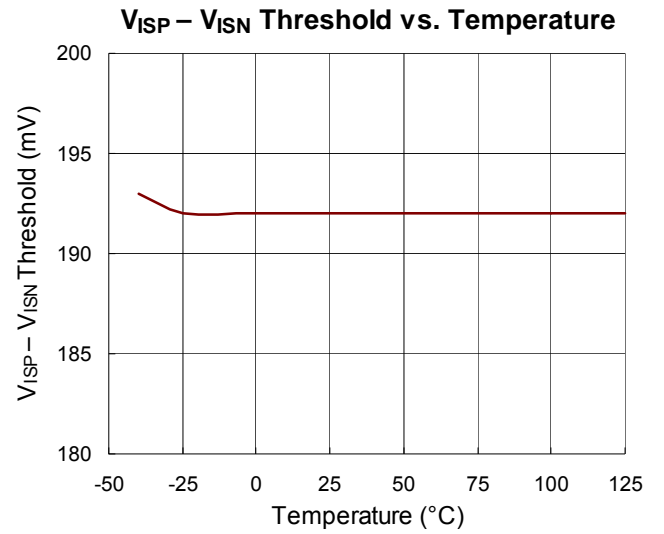
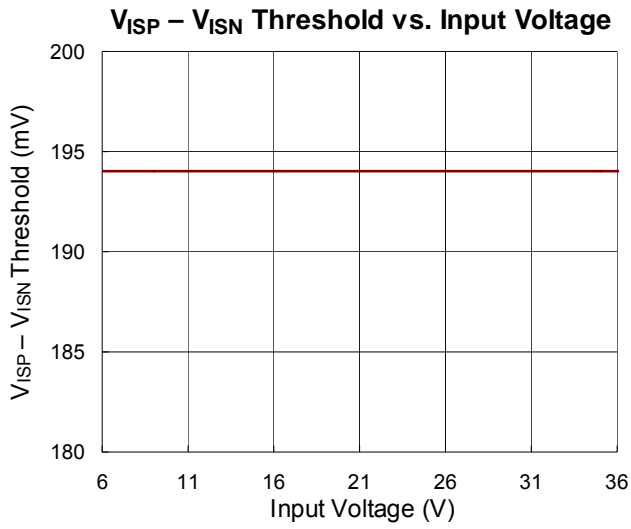

OVP vs. Input Voltage

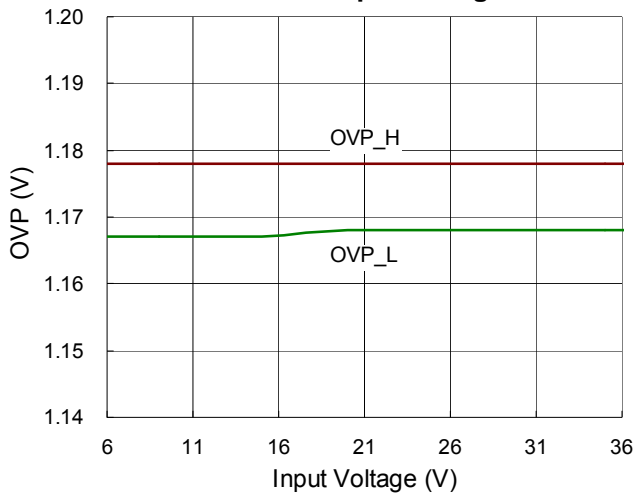

GATE Voltage vs. Input Voltage

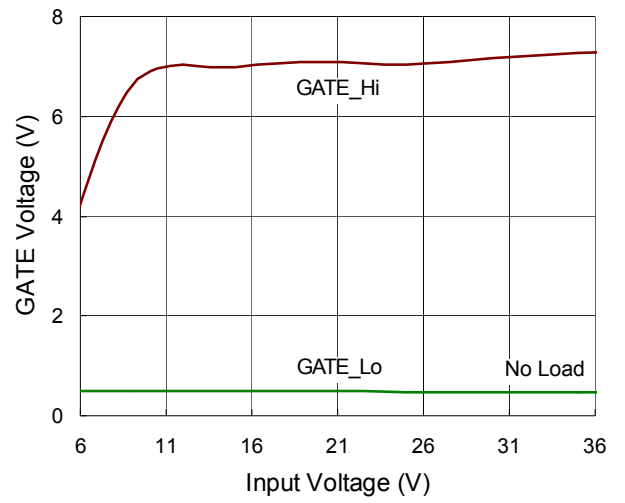

Power On from EN

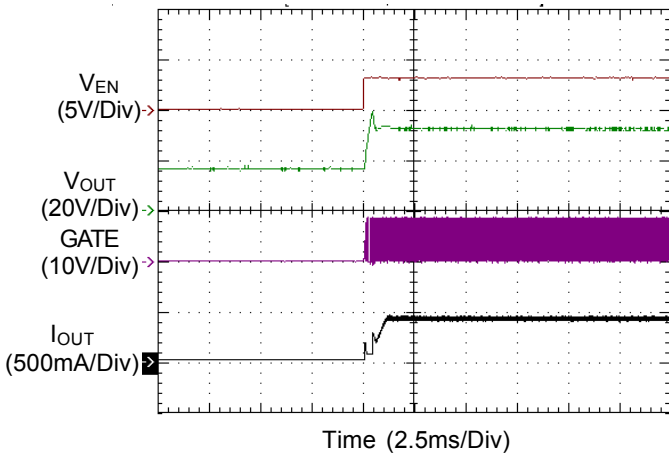

Power Off from EN

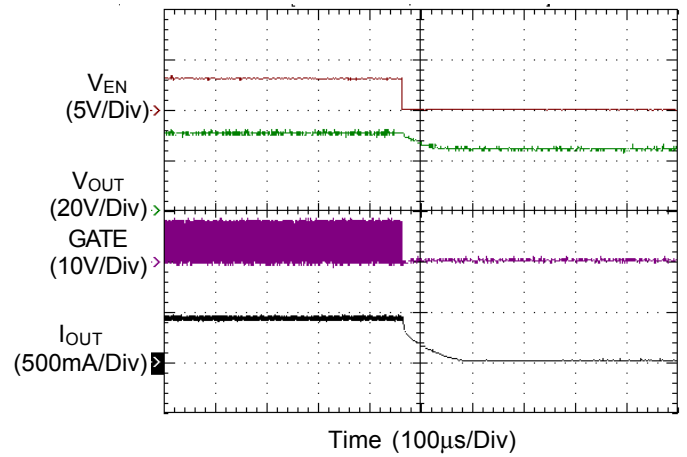

Applications Information

The RT8475 is a current mode PWM controller designed to drive an external MOSFET for high current LED applications. The LED current can be programmed by an external resistor. The input voltage range of the RT8475 can be up to 36V and the output voltage can be up to 90V. The RT8475 provides analog and PWM dimming to achieve LED current control.

GBIAS Regulator and Bypass Capacitor

The GBIAS pin requires a capacitor for stable operation and to store the charge for the large GATE switching currents. Choose a 25V rated low ESR, X7R or X5R ceramic capacitor for best performance. The value of a 1 μ F capacitor will be adequate for many applications.

Place the capacitor close to the IC to minimize the trace length to the GBIAS pin and also to the IC ground. An internal current limit on the GBIAS output protects the RT8475 from excessive on-chip power dissipation.

The GBIAS pin has its own under-voltage disable (UVLO) set to 4.3V(typical) to protect the external FETs from excessive power dissipation caused by not being fully enhanced. If the input voltage, VIN, will not exceed 8V, then the GBIAS pin should be connected to the input supply. Be aware if GBIAS supply is used to drive extra circuits besides RT8475, typically the extra GBIAS load should be limited to less than 10mA.

Loop Compensation

The RT8475 uses an internal error amplifier whose compensation pin (VC) allowing the loop response optimized for specific application. The external inductor, output capacitor and the compensation resistor and capacitor determine the loop stability. The inductor and output capacitor are chosen based on performance, size and cost. The compensation resistor and capacitor at VC are selected to optimize control loop response and stability. For typical LED applications, a 3.3nF compensation capacitor at VC is adequate, and a series resistor should always be used to increase the slew rate on the VC pin to maintain tighter regulation of LED current during fast transients on the input supply to the converter an external resistor in series with a capacitor is connected

from the VC pin to GND to provide a pole and a zero for proper loop compensation. The typical compensation for the RT8475 is 10k Ω and 3.3nF.

Soft-Start

The soft-start of the RT8475 can be achieved by connecting a capacitor from SS pin to GND. The built-in soft-start circuit reduces the start-up current spike and output voltage overshoot. The soft-start time is determined by the external capacitor charged by an internal 6 μ A constant charging current. The SS pin directly limits the rate of voltage rise on the VC pin, which in turn limits the peak switch current.

The soft-start interval is set by the soft-start capacitor selection according to the equation :

$$t_{SS} = C_{SS} \times \frac{2.4V}{6\mu A}$$

A typical value for the soft-start capacitor is 0.1 μ F. The soft-start capacitor is discharged when EN/UVLO falls below its threshold, during an over temperature event or during an GBIAS under voltage event.

LED Current Setting

The LED current is programmed by placing an appropriate value current sense resistor between the ISP and ISN pins. Typically, sensing of the current should be done at the top of the LED string. The ACTL pin should be tied to a voltage higher than 1.2V to get the full-scale 190mV (typical) threshold across the sense resistor. The ACTL pin can also be used to dim the LED current to zero, although relative accuracy decreases with the decreasing voltage sense threshold. When the ACTL pin voltage is less than 1.2V, the LED current is :

$$I_{LED} = \frac{(V_{ACTL} - 0.2) \times 0.19}{R_{SENSE}}$$

Where,

R_{SENSE} is the resistor between ISP and ISN.

When the voltage of ACTL is higher than 1.2V, the LED current is regulated to :

$$I_{LED(MAX)} = \frac{190mV}{R_{SENSE}}$$

The ACTL pin can also be used in conjunction with a thermistor to provide over temperature protection for the LED load, or with a voltage divider to V_{IN} to reduce output power and switching current when V_{IN} is low. The presence of a time varying differential voltage signal (ripple) across ISP and ISN at the switching frequency is expected.

The amplitude of this signal is increased by high LED load current, low switching frequency and/or a smaller value output filter capacitor. The compensation capacitor on the VC pin filters the signal so the average difference between ISP and ISN is regulated on the user-programmed value.

Programmable Switching Frequency

The RSET frequency adjust pin allows the user to program the switching frequency from 100kHz to 1MHz for optimized efficiency and performance or external component size. Higher frequency operation allows for smaller component size but increases switching losses and gate driving current, and may not allow sufficiently high or low duty cycle operation. Lower frequency operation gives better performance but with larger external component size. For an appropriate R_{RSET} resistor value see Table 1 or Figure 5. An external resistor from the RSET pin to GND is required-do not leave this pin open.

Table 1. Switching Frequency vs. R_{RSET} Value (1% Resistor)

f_{OSC} (KHZ)	R_{RSET} (k Ω)
1000	8.34
800	11.41
600	16.68
500	20.9
300	38.04
200	60.35
100	130

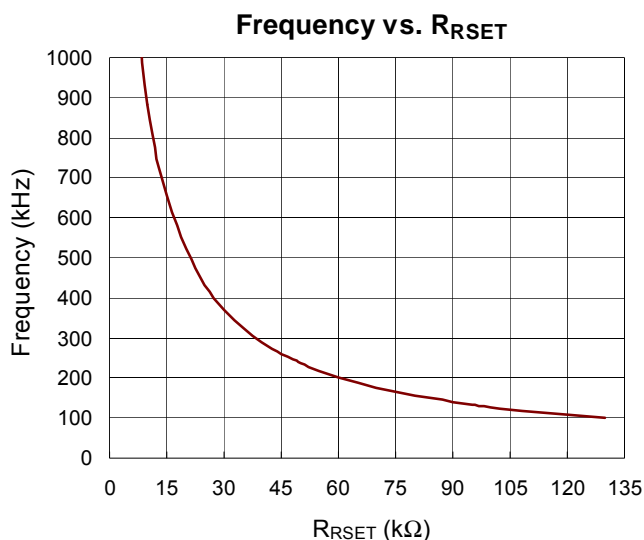

Figure 5. Switching Frequency vs. R_{RSET}

Output Over Voltage Setting

The RT8475 is equipped with Over Voltage Protection (OVP) function. When the voltage at OVP pin exceeds a threshold of approximately 1.18V, the power switch is turned off. The power switch can be turned on again once the voltage at OVP pin drops below 1.18V. For the Boost and Buck-Boost application, the output voltage could be clamped at a certain voltage level. The OVP voltage can be set by the following equation :

$$V_{OUT, OVP} = 1.18 \times \left(1 + \frac{R1}{R2} \right)$$

Where,

R1 and R2 are the voltage dividers from V_{OUT} to GND with the divider center node connected to OVP pin.

Over Temperature Protection

The RT8475 has Over Temperature Protection (OTP) function to prevent the excessive power dissipation from overheating. The OTP function will shut down switching operation when the die junction temperature exceeds 145°C. The chip will automatically start to switch again when the die junction temperature cools off.

Inductor Selection

The converter operates in discontinuous conduction mode when the inductance value is less than the value LBCM. With an inductance greater than LBCM, the converter operates in Continuous Conduction Mode (CCM). The inductance LBCM is determined by the following equations.

For Buck application :

$$L_{BCM} = \frac{V_{OUT}}{2 \times I_{OUT} \times f} \times \left(\frac{V_{IN} - V_{OUT}}{V_{IN}} \right)$$

For Boost application :

$$L_{BCM} = \frac{V_{IN}^2}{2 \times I_{OUT} \times f} \times \left(\frac{V_{OUT} - V_{IN}}{V_{OUT}^2} \right)$$

For Buck-Boost application :

$$L_{BCM} = \frac{V_{IN}^2}{2 \times I_{OUT} \times f} \times \frac{V_{OUT}}{(V_{IN} + V_{OUT})^2}$$

where

V_{OUT} = output voltage.

V_{IN} = input voltage.

f = operating frequency.

I_{OUT} = LED current.

Choose an inductance based on the operating frequency, input voltage and output voltage to provide a current mode ramp signal during the MOSFET on period for PWM control loop regulation. The inductance also determines the inductor ripple current. Operating the converter in CCM is recommended, which will have the smaller inductor ripple current and hence the less conduction losses from all converter components.

As a design example, to design the peak to peak inductor ripple to be $\pm 30\%$ of the output current, the following equations can be used to estimate the size of the needed inductance :

For Buck application :

$$L = \frac{V_{OUT}}{2 \times 0.3 \times I_{OUT} \times f} \times \left(\frac{V_{IN} - V_{OUT}}{V_{IN}} \right)$$

For Boost application :

$$L = \frac{V_{IN}^2}{2 \times 0.3 \times I_{OUT} \times f} \times \left(\frac{V_{OUT} - V_{IN}}{V_{OUT}^2} \right)$$

For Buck-Boost application :

$$L = \frac{V_{IN}^2}{2 \times 0.3 \times I_{OUT} \times f} \times \frac{V_{OUT}}{(V_{IN} + V_{OUT})^2}$$

The inductor must also be selected with a saturation current rating greater than the maximum inductor current during normal operation. The maximum inductor current can be calculated by the following equations.

For Buck application :

$$I_{PEAK} = I_{OUT} + \frac{V_{OUT}}{2 \times L \times f} \times \left(\frac{V_{IN} - V_{OUT}}{V_{IN}} \right)$$

For Boost application :

$$I_{PEAK} = \frac{V_{OUT}}{V_{IN} \times \eta} \times I_{OUT} + \frac{V_{OUT} - V_{IN}}{2 \times f \times L} \times \left(\frac{V_{IN}}{V_{OUT}} \right)^2$$

For Buck-Boost application :

$$I_{PEAK} = \frac{V_{OUT} + V_{IN} \times \eta}{V_{IN} \times \eta} \times I_{OUT} + \frac{V_{OUT}}{2 \times f \times L} \times \left(\frac{V_{IN}}{V_{IN} + V_{OUT}} \right)^2$$

where

η is the efficiency of the power converter.

Power MOSFET Selection

For applications operating at high input or output voltages, the power N-MOS FET switch is typically chosen for drain voltage V_{DS} rating and low gate charge. Consideration of switch on-resistance, $R_{DS(ON)}$, is usually secondary because switching losses dominate power loss. The GBIAS regulator on the RT8475 has a fixed current limit to protect the IC from excessive power dissipation at high V_{IN} , so the N-MOSFET should be chosen so that the product of Q_g at 5V and switching frequency does not exceed the GBIAS current limit.

Moreover, to obtain better conversion efficiency, GATE high level must be higher than the gate threshold voltage $V_{gs(th)}$ of the power N-MOSFET. If GATE high level is lower, an external totem pole circuit has to be added.

ISW Sense Resistor Selection

The resistor, R_{SW} , between the Source of the external N-MOSFET and GND should be selected to provide adequate switch current to drive the application without exceeding the current limit threshold set by the ISW pin sense threshold of RT8475. The ISW sense resistor value can be calculated according to the formula below :

$$R_{SW} = \frac{\text{current limit threshold minimum value}}{I_{OCP}}$$

where I_{OCP} is about 1.33 to 1.5 times of inductor peak current I_{PEAK} .

The placement of R_{SW} should be close to the source of the N-MOSFET and the IC GND of the RT8475. The ISW pin input to RT8475 should be a Kelvin sense connection to the positive terminal of R_{SW} .

Schottky Diode Selection

The Schottky diode, with their low forward voltage drop and fast switching speed, is necessary for the RT8475 applications. In addition, power dissipation, reverse voltage rating and pulsating peak current are the important parameters for the Schottky diode selection. Choose a suitable Schottky diode whose reverse voltage rating is greater than maximum output voltage. The diode's average current rating must exceed the average output current. The diode conducts current only when the power switch is turned off (typically less than 50% duty cycle). If using the PWM feature for dimming, it is important to consider diode leakage, which increases with the temperature, from the output during the PWM low interval. Therefore, choose the Schottky diode with sufficiently low leakage current.

Capacitor Selection

The input capacitor reduces current spikes from the input supply and minimizes noise injection to the converter. For most of the RT8475 applications, a 10 μ F ceramic capacitor is sufficient. A value higher or lower may be used depending on the noise level from the input supply and the input current to the converter.

In Boost application, the output capacitor is typically a ceramic capacitor and is selected based on the output voltage ripple requirements. The minimum value of the output capacitor C_{OUT} is approximately given by the following equation :

$$C_{OUT} = \frac{I_{OUT} \times V_{OUT}}{V_{IN} \times V_{RIPPLE} \times f_{SW}}$$

For LED applications, the equivalent resistance of the LED is typically low and the output filter capacitor should be sized to attenuate the current ripple. Use of X7R type ceramic capacitors is recommended. Lower operating frequencies will require proportionately higher capacitor values.

Thermal Considerations

For continuous operation, do not exceed absolute maximum junction temperature. The maximum power dissipation depends on the thermal resistance of the IC package, PCB layout, rate of surrounding airflow, and difference between junction and ambient temperature. The maximum power dissipation can be calculated by the following formula :

$$P_{D(MAX)} = (T_{J(MAX)} - T_A) / \theta_{JA}$$

where $T_{J(MAX)}$ is the maximum junction temperature, T_A is the ambient temperature, and θ_{JA} is the junction to ambient thermal resistance.

For recommended operating condition specifications, the maximum junction temperature is 125°C. The junction to ambient thermal resistance, θ_{JA} , is layout dependent. For WQFN-16L 3x3 package, the thermal resistance, θ_{JA} , is 68°C/W on a standard JEDEC 51-7 four-layer thermal test board. For SOP-14 package, the thermal resistance, θ_{JA} , is 100°C/W on a standard JEDEC 51-3 single-layer thermal test board. The maximum power dissipation at $T_A = 25^\circ\text{C}$ can be calculated by the following formula :

$$P_{D(MAX)} = (125^\circ\text{C} - 25^\circ\text{C}) / (68^\circ\text{C/W}) = 1.471\text{W for WQFN-16L 3x3 package}$$

$$P_{D(MAX)} = (125^\circ\text{C} - 25^\circ\text{C}) / (100^\circ\text{C/W}) = 1.0\text{W for SOP-14 package}$$

The maximum power dissipation depends on the operating ambient temperature for fixed $T_{J(MAX)}$ and thermal resistance, θ_{JA} . The derating curves in Figure 6 allow the designer to see the effect of rising ambient temperature on the maximum power dissipation.

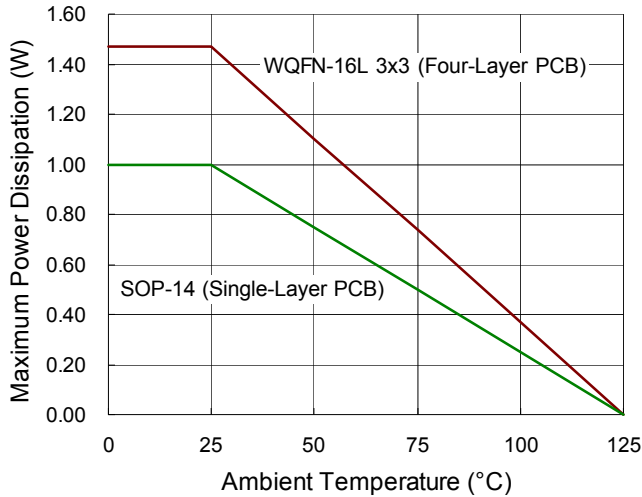

Figure 6. Derating Curve of Maximum Power Dissipation

Layout Consideration

PCB layout is very important to design power switching converter circuits. The layout guidelines are suggested as follows :

- ▶ The power components L1, D1, C_{IN}, M1 and C_{OUT} must be placed as close to each other as possible to reduce the ac current loop area. The PCB trace between power components must be as short and wide as possible due to large current flow through these traces during operation.
- ▶ The input capacitor C_{VCC} must be placed as close to VCC pin as possible.
- ▶ Place the compensation components to VC pin as close as possible to avoid noise pick up.
- ▶ Connect GND pin and Exposed Pad to a large ground plane for maximum power dissipation and noise reduction.

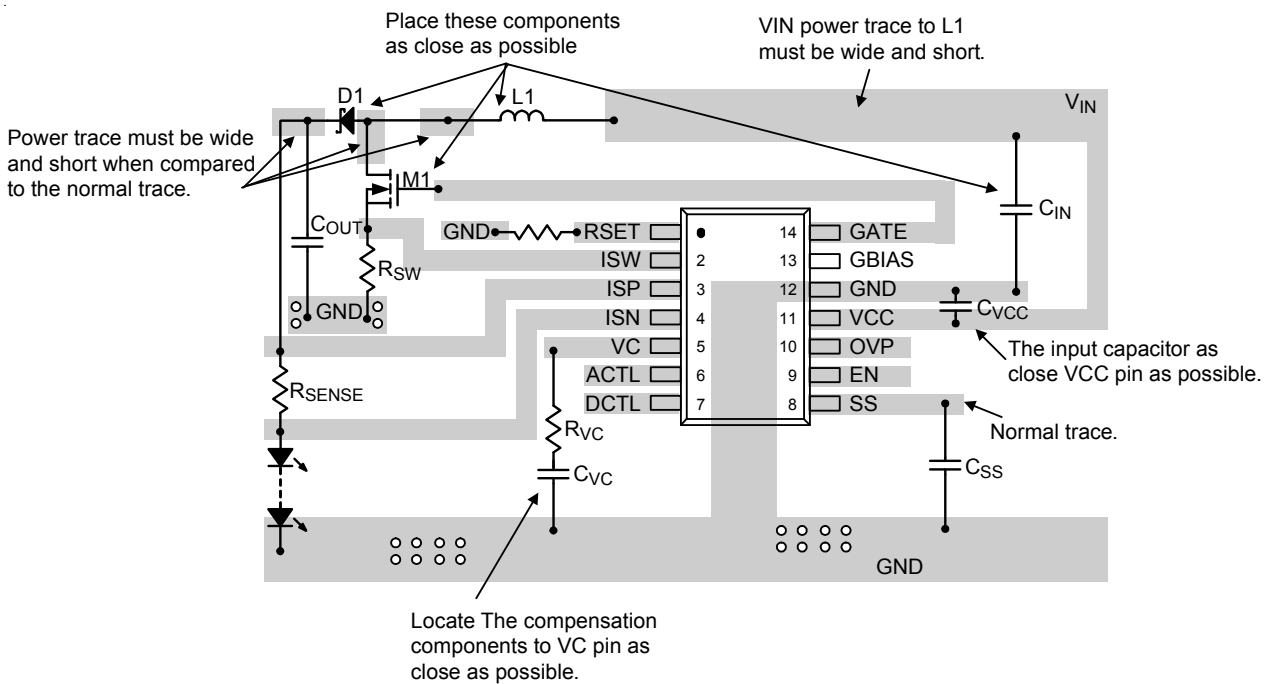
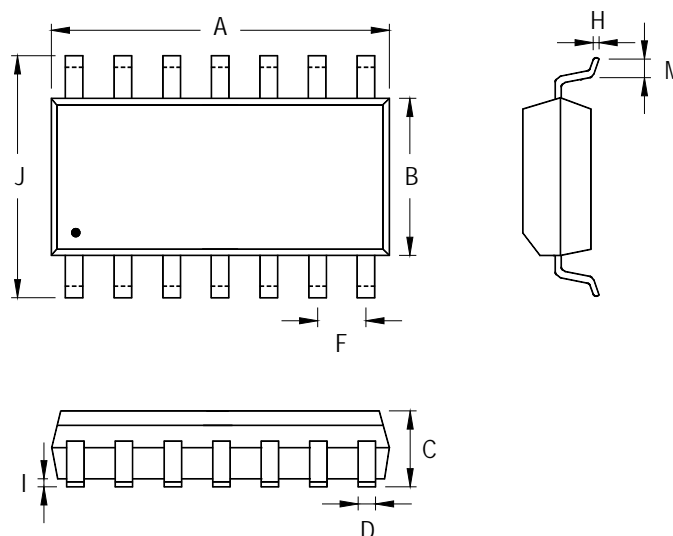

Figure 7. PCB Layout Guide

Outline Dimension



Symbol	Dimensions In Millimeters		Dimensions In Inches	
	Min	Max	Min	Max
A	8.534	8.738	0.336	0.344
B	3.810	3.988	0.150	0.157
C	1.346	1.753	0.053	0.069
D	0.330	0.508	0.013	0.020
F	1.194	1.346	0.047	0.053
H	0.178	0.254	0.007	0.010
I	0.102	0.254	0.004	0.010
J	5.791	6.198	0.228	0.244
M	0.406	1.270	0.016	0.050

14-Lead SOP Plastic Package

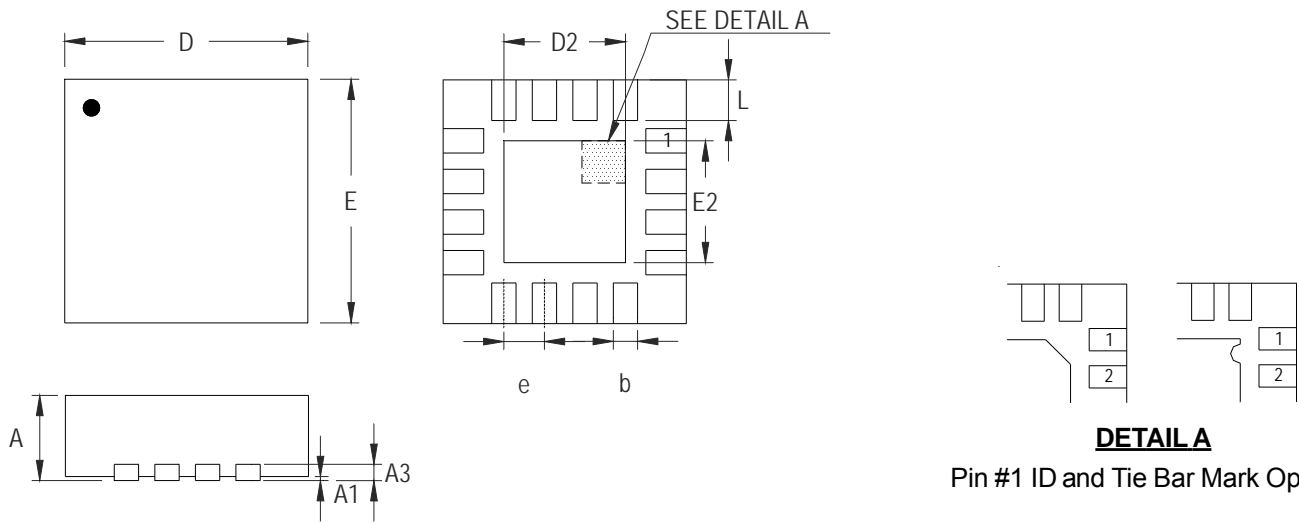

Pin #1 ID and Tie Bar Mark Options

Note : The configuration of the Pin #1 identifier is optional, but must be located within the zone indicated.

Symbol	Dimensions In Millimeters		Dimensions In Inches	
	Min	Max	Min	Max
A	0.700	0.800	0.028	0.031
A1	0.000	0.050	0.000	0.002
A3	0.175	0.250	0.007	0.010
b	0.180	0.300	0.007	0.012
D	2.950	3.050	0.116	0.120
D2	1.300	1.750	0.051	0.069
E	2.950	3.050	0.116	0.120
E2	1.300	1.750	0.051	0.069
e	0.500		0.020	
L	0.350	0.450	0.014	0.018

W-Type 16L QFN 3x3 Package

Richtek Technology Corporation

14F, No. 8, Tai Yuen 1st Street, Chupei City
 Hsinchu, Taiwan, R.O.C.
 Tel: (8863)5526789

Richtek products are sold by description only. Richtek reserves the right to change the circuitry and/or specifications without notice at any time. Customers should obtain the latest relevant information and data sheets before placing orders and should verify that such information is current and complete. Richtek cannot assume responsibility for use of any circuitry other than circuitry entirely embodied in a Richtek product. Information furnished by Richtek is believed to be accurate and reliable. However, no responsibility is assumed by Richtek or its subsidiaries for its use; nor for any infringements of patents or other rights of third parties which may result from its use. No license is granted by implication or otherwise under any patent or patent rights of Richtek or its subsidiaries.

Looking for pricing, stock, or lifecycle information?

Click below to explore more details on WIN SOURCE:

 [View RT8475ZS on WIN SOURCE](#)

 [Richtek USA Inc. Information](#)

Optimize Your Supply Chain with WIN SOURCE Solutions

-  Global Sourcing Solution
-  Obsolete Management
-  Cost Control Management
-  Shortage Management
-  Alternative Solution
-  Excess Inventory Management