

THIS DRAWING IS UNPUBLISHED. RELEASED FOR PUBLICATION
 © COPYRIGHT - BY TYCO ELECTRONICS CORPORATION. ALL RIGHTS RESERVED.

LOC DIST
 GW 00

REVISIONS				
P	LTR	DESCRIPTION	DATE	APVD
A		W0 00/7018	21AUG2000	KM KM
B		Update Lead-free part	03APR2006	AH RL
B1		Optional PCB-pads added	03APR2006	AH RL
B2		RoHS compliant	27.06.2006	AM DB

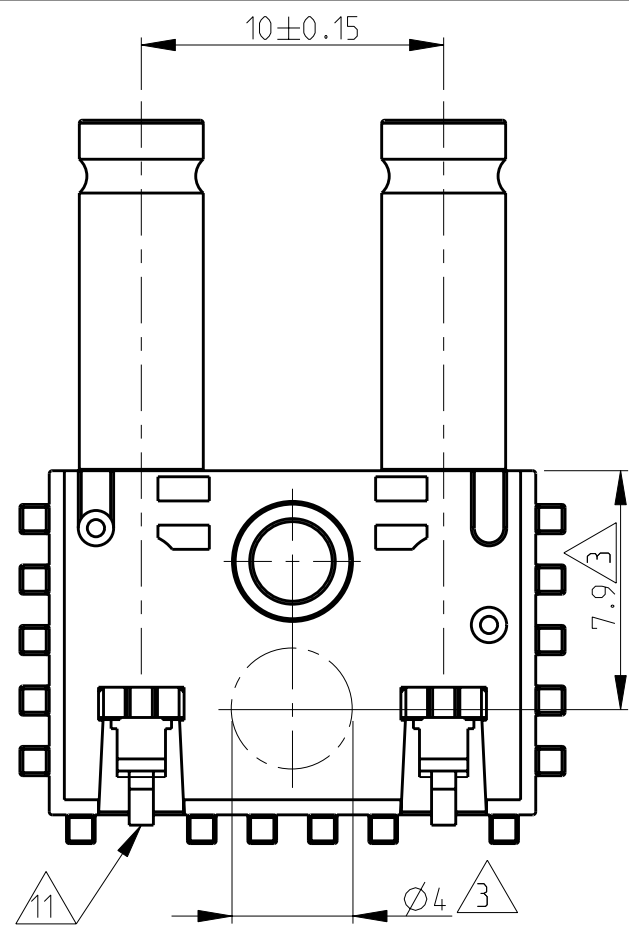

11 Signal contact solder lead

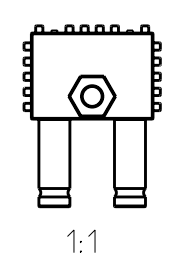
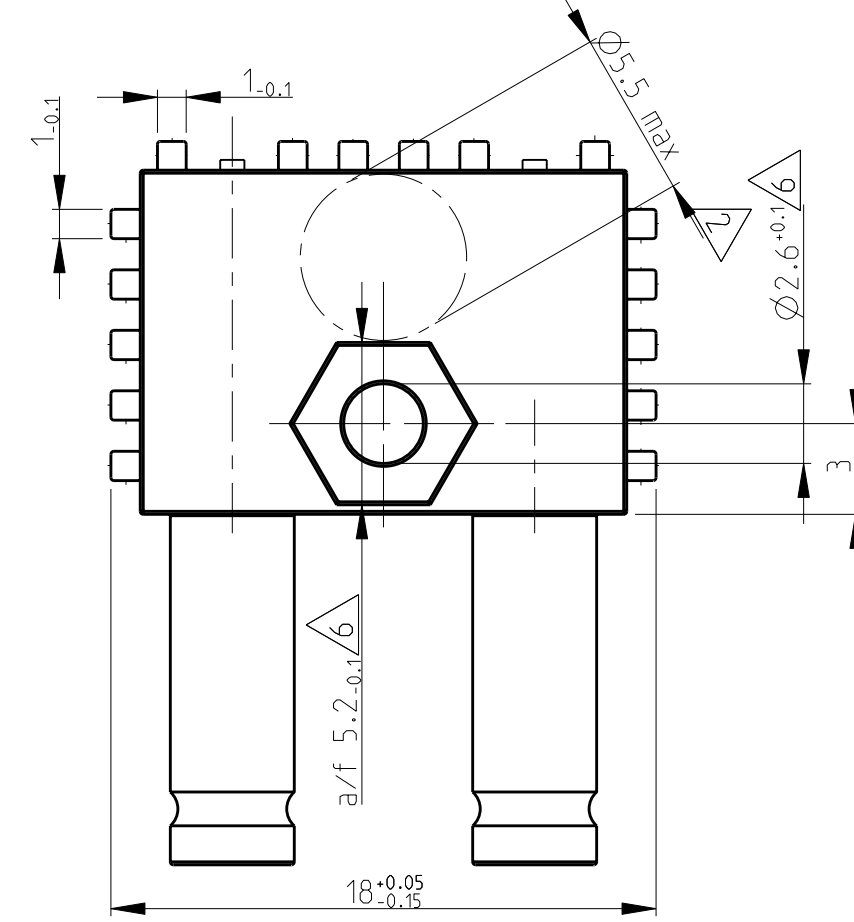
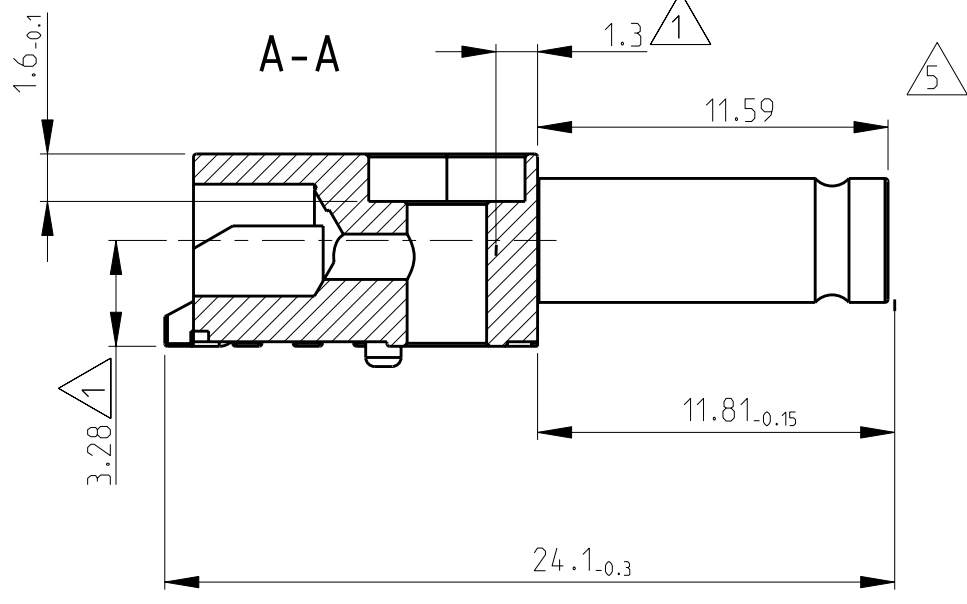
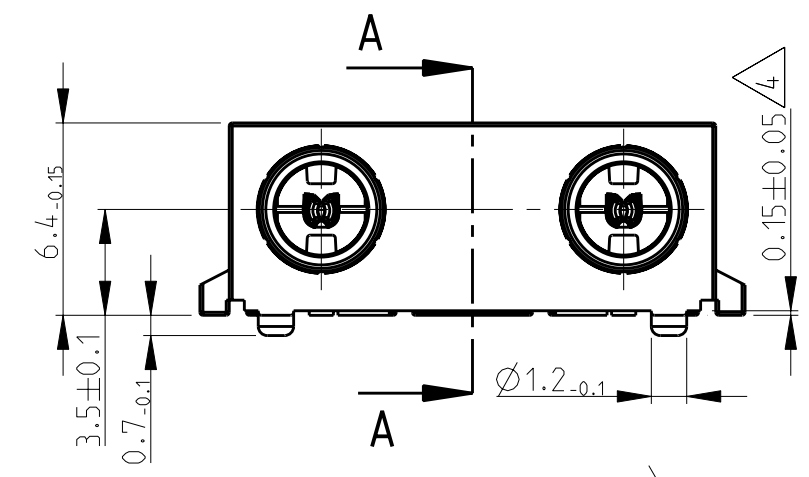

3D VIEW
 5:1

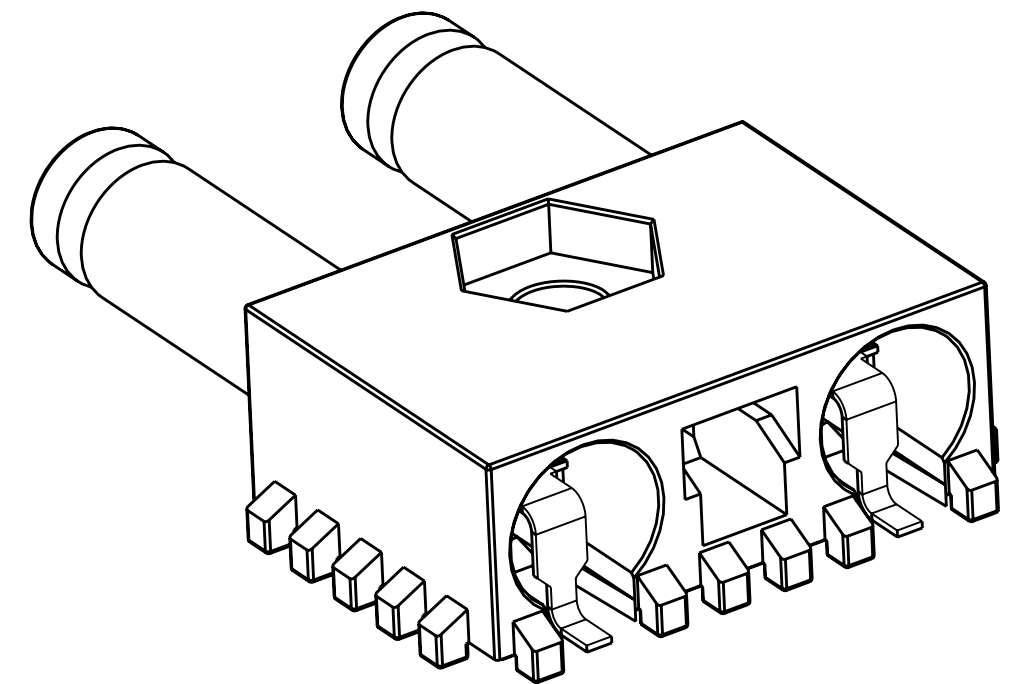

PC-Board layout

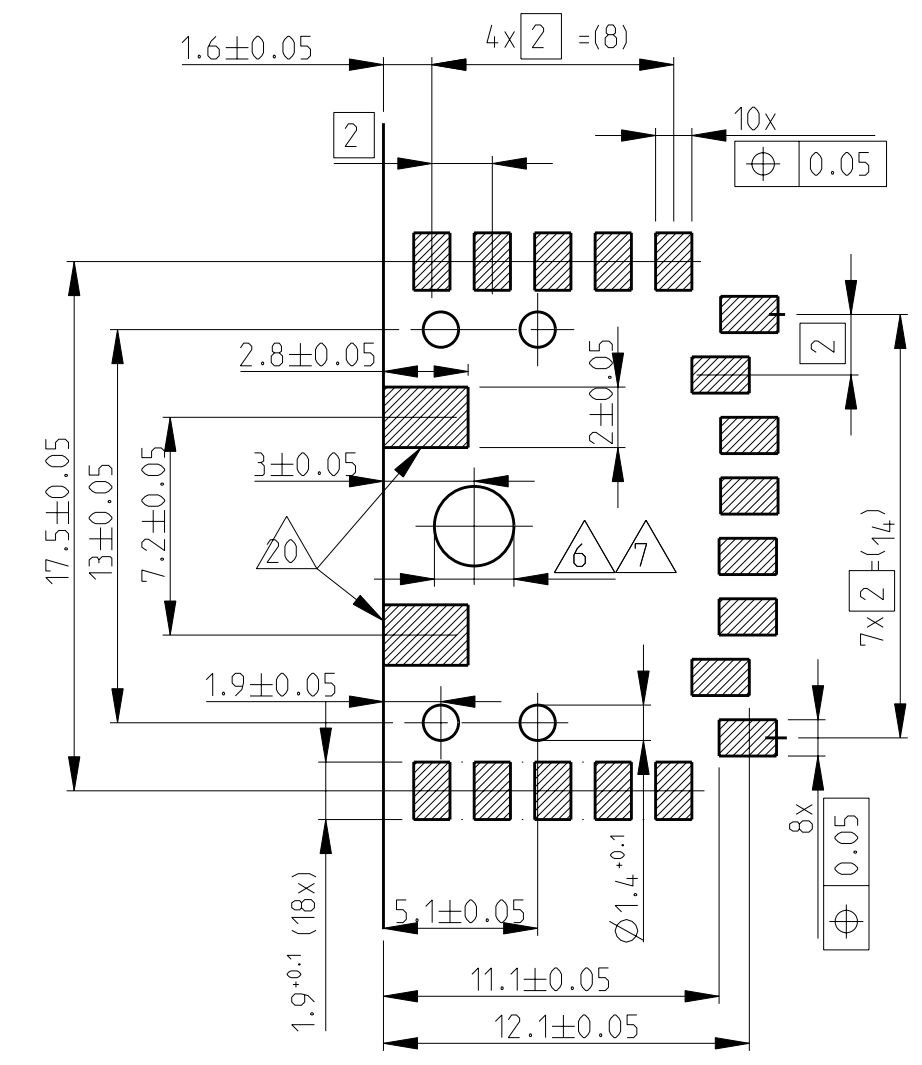

Optional solder pads
 Soldering surfaces

Packaging: Tape & Reel

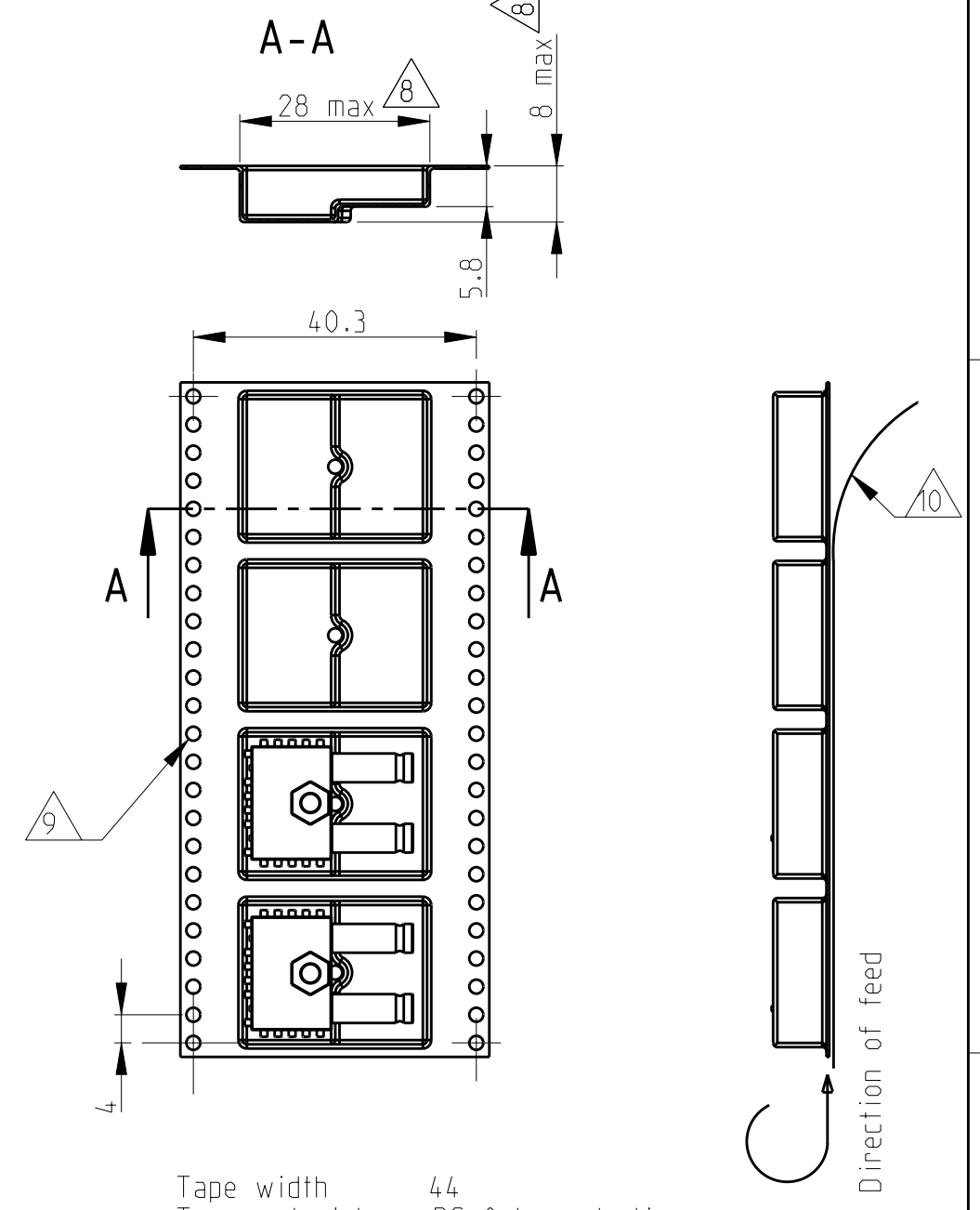

Tape width 44
 Tape material PS 0.4 conductive
 Cavity pitch 24
 Reel Ø 330
 Pieces/reel 350

Further features according EIA-481-3

cover tape
 Round sprocket holes
 Reference dimension for tape feeder clearance only

Coplanarity of all SMD solder terminals: 0.15 max.
 Component weight: 3.5 gram max.

- △ Diameter depending on placement tolerances
- △ Hole suitable for screw M2.5.
- △ Mating face and snap-lock coupling according series 1.0/2.3
- △ Stand off
- △ Glue area
- △ Plane surface for automatic placement with suction pipette
- △ Gravity point (CAD deduced)

THIS DRAWING IS A CONTROLLED DOCUMENT FOR TYCO ELECTRONICS CORPORATION IT IS SUBJECT TO CHANGE AND THE CONTROLLING ENGINEERING ORGANIZATION SHOULD BE CONTACTED FOR THE LATEST REVISION.		DWN Vermaete 03NOV1997	Tyco Electronics Oostkamp - Belgium
DIMENSIONS: mm		CHK Vermaete 03NOV1997	
TOLERANCES UNLESS OTHERWISE SPECIFIED:		APVD Vermaete 03NOV1997	NAME 1.0-2.3 Jack 2 posiz. Siemax (V23614-A1227-B7)
0 PLC ±	1 PLC ±	PRODUCT SPEC	SIZE A2
2 PLC ±	3 PLC ±	APPLICATION SPEC	CAGE CODE 00779
4 PLC ±	ANGLES ±	WEIGHT -	DRAWING NO. C-6-1393896-2
MATERIAL -	FINISH -	CUSTOMER DRAWING	SCALE 4:1 SHEET 1 OF 1 REV B2

Looking for pricing, stock, or lifecycle information?

Click below to explore more details on WIN SOURCE:

 [View 6-1393696-2 on WIN SOURCE](#)

 [TE Connectivity](#) Information

Optimize Your Supply Chain with WIN SOURCE Solutions

-  Global Sourcing Solution
-  Obsolete Management
-  Cost Control Management
-  Shortage Management
-  Alternative Solution
-  Excess Inventory Management