



THE DATASHEET OF RLS245



Switching diode

RLS245

●Applications

High voltage switching
General purpose rectification

●Features

- 1) Small surface mounting type. (LLDS)
- 2) $V_{RM}=250V$ guaranteed.
- 3) High reliability

●Construction

Silicon epitaxial planar

●External dimensions (Units : mm)

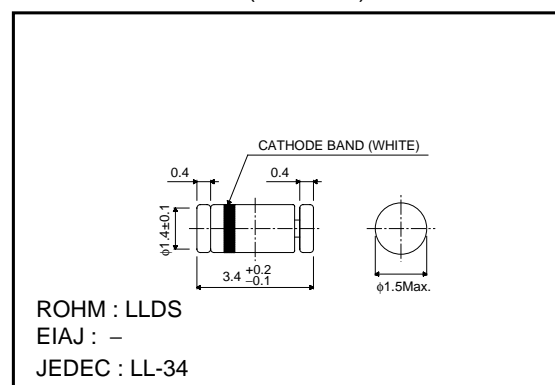

●Absolute maximum ratings (Ta=25°C)

| Parameter | Symbol | Limits | Unit |
|-------------------------|-------------|----------|------|
| Peak reverse voltage | V_{RM} | 250 | V |
| DC reverse voltage | V_R | 220 | V |
| Peak forward current | I_{FM} | 625 | mA |
| Mean rectifying current | I_o | 200 | mA |
| Surge current (1s) | I_{surge} | 1000 | mA |
| Power dissipation | P | 300 | mW |
| Junction temperature | T_j | 175 | °C |
| Storage temperature | T_{stg} | -65~+175 | °C |

●Electrical characteristics (Ta=25°C)

| Parameter | Symbol | Min. | Typ. | Max. | Unit | Conditions |
|-------------------------------|----------|------|------|------|---------|------------------------------------|
| Forward voltage | V_F | - | - | 1.5 | V | $I_F=200mA$ |
| Reverse current | I_R | - | - | 10 | μA | $V_R=220V$ |
| Capacitance between terminals | C_T | - | - | 3 | pF | $V_R=0V, f=1MHz$ |
| Reverse recovery time | t_{rr} | - | - | 75 | ns | $I_F=20mA, I_R=20mA, R_L=50\Omega$ |

Diodes

●Electrical characteristic curves (Ta=25°C)

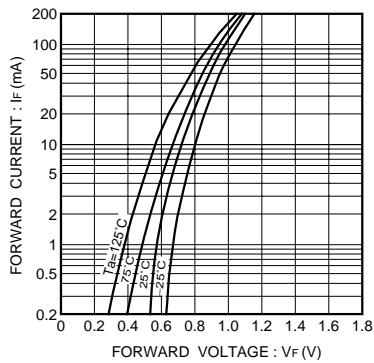

Fig. 1 Forward characteristics

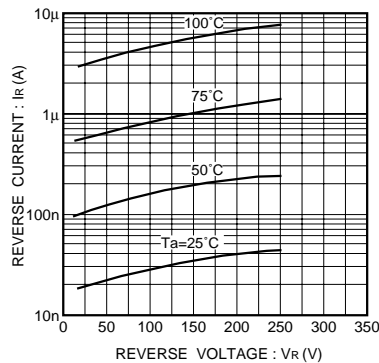

Fig. 2 Reverse characteristics

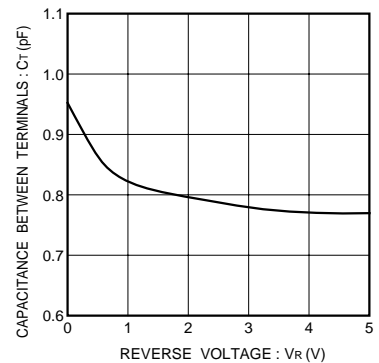

Fig. 3 Capacitance between terminals characteristics

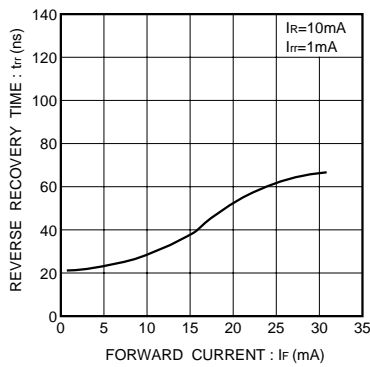

Fig. 4 Reverse recovery time characteristics

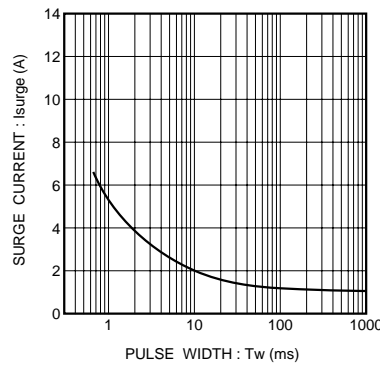

Fig. 5 Surge current characteristics

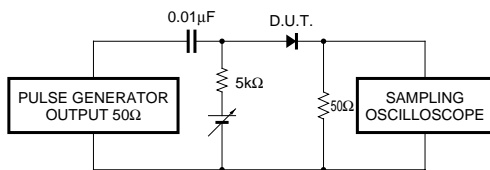





Fig. 6 Reverse recovery time (tr) measurement circuit

Looking for pricing, stock, or lifecycle information?

Click below to explore more details on WIN SOURCE:

-  [View RLS245](#) on WIN SOURCE
-  [Rohm Semiconductor](#) Information

Optimize Your Supply Chain with WIN SOURCE Solutions

-  Global Sourcing Solution
-  Obsolete Management
-  Cost Control Management
-  Shortage Management
-  Alternative Solution
-  Excess Inventory Management