



**THE DATASHEET OF
REF3033AIDBZR**



REF30xx 50-ppm/°C Max, 50- μ A, CMOS Voltage Reference in SOT-23-3

1 Features

- microSize Package: SOT-23-3
- Low Dropout: 1 mV
- High Output Current: 25 mA
- High Accuracy: 0.2%
- Low I_Q : 42 μ A (Typical)
- Excellent Specified Drift Performance:
 - 50 ppm/°C (Maximum) From 0°C to 70°C
 - 75 ppm/°C (Maximum) From –40°C to +125°C

2 Applications

- Temperature and Pressure Transmitters
- Portable, Battery-Powered Equipment
- Data Acquisition Systems
- Medical Equipment
- Handheld Test Equipment

3 Description

The REF30xx is a precision, low-power, low-dropout voltage, reference family available in a tiny 3-pin SOT-23 package. The REF30xx offers excellent temperature drift and initial accuracy while operating at a quiescent current of 42 μ A (typical).

The low power consumption and the relatively high precision make the REF30xx very attractive for loop-powered industrial applications such as pressure and temperature transmitter applications. The REF30xx is easy to use in intrinsically safe and explosion-proof applications because it does not require a load capacitor to be stable. The REF30xx is specified over the extended industrial temperature range of –40°C to +125°C.

The REF30xx operates with supplies within 1 mV of output voltage under zero-load conditions. Engineers can use the low dropout, small size, and low power consumption of the REF30xx in portable and battery-powered applications.

Device Information

PART NUMBER	PACKAGE	BODY SIZE (NOM)
REF30xx	SOT-23 (3)	2.92 mm × 1.30 mm

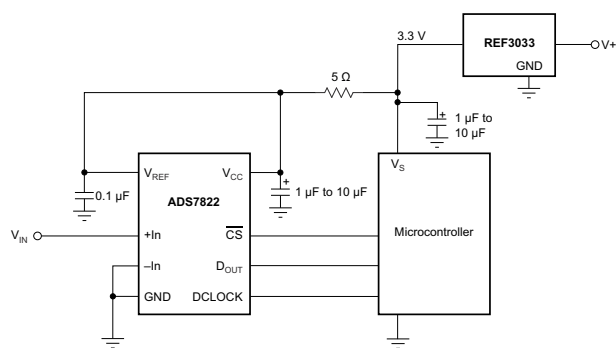

Typical Application

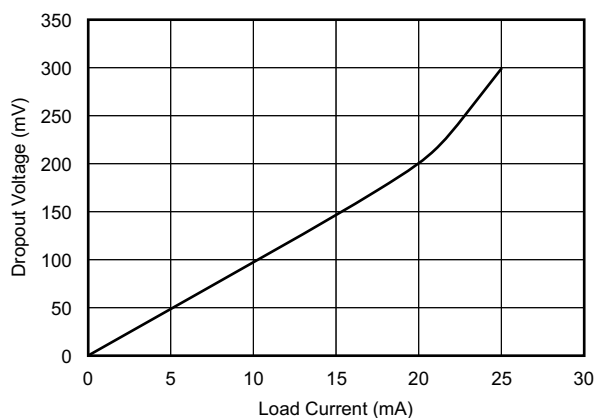

Dropout Voltage vs Load Current



Table of Contents

1 Features	1	9 Application and Implementation	15
2 Applications	1	9.1 Application Information.....	15
3 Description	1	9.2 Typical Application.....	15
4 Revision History	2	10 Power Supply Recommendations	17
5 Device Comparison Table	3	11 Layout	17
6 Pin Configuration and Functions	3	11.1 Layout Guidelines.....	17
7 Specifications	4	11.2 Layout Example.....	17
7.1 Absolute Maximum Ratings.....	4	12 Device and Documentation Support	18
7.2 ESD Ratings.....	4	12.1 Documentation Support.....	18
7.3 Recommended Operating Conditions.....	4	12.2 Related Links.....	18
7.4 Thermal Information.....	4	12.3 Receiving Notification of Documentation Updates..	18
7.5 Electrical Characteristics.....	5	12.4 Support Resources.....	18
7.6 Typical Characteristics.....	7	12.5 Trademarks.....	18
8 Detailed Description	11	12.6 Electrostatic Discharge Caution.....	18
8.1 Overview.....	11	12.7 Glossary.....	18
8.2 Functional Block Diagram.....	11	13 Mechanical, Packaging, and Orderable	
8.3 Feature Description.....	11	Information	18
8.4 Device Functional Modes.....	13		

4 Revision History

NOTE: Page numbers for previous revisions may differ from page numbers in the current version.

Changes from Revision H (February 2018) to Revision I (July 2022) Page

- Updated the numbering format for tables, figures, and cross-references throughout the document..... 1

Changes from Revision G (November 2015) to Revision H (February 2018) Page

- Changed section header From: REF33xx (REF3312, REF3318, REF3320, REF3325, REF3330, REF3333)
To: REF30xx (REF3012, REF3020, REF3025, REF3030, REF30333, REF3040) in the [Section 7.5](#) 5
- Added turnon settling time TYP value of 120 μ s (deleted by mistake in the previous revision) 5
- Added NOTE to the [Section 9](#) section 15

Changes from Revision F (August 2008) to Revision G (November 2015) Page

- Added *Device Information, ESD Ratings, Recommended Operating Conditions, and Thermal Information* tables..... 1
- Added *Detailed Description, Applications and Implementation, Power-Supply Recommendations, Layout, Device and Documentation Support, and Mechanical, Packaging, and Orderable Information* sections..... 1
- Changed text in *Description* section 1
- Deleted thermal resistance parameter in Electrical Characteristics; see new Thermal Information table..... 5
- Moved temperature parameters from Electrical Characteristics to Recommended Operating Conditions..... 5

5 Device Comparison Table

PART NUMBER	VOLTAGE (V)
REF3012	1.25
REF3020	2.048
REF3025	2.5
REF3030	3.0
REF3033	3.3
REF3040	4.096

6 Pin Configuration and Functions

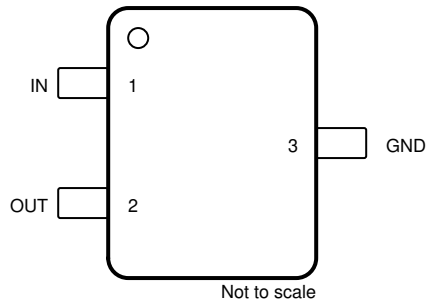

Figure 6-1. DBZ Package 3-Pin SOT-23 Top View

Table 6-1. Pin Functions

PIN		I/O	DESCRIPTION
NO.	NAME		
1	IN	Input	Input supply voltage
2	OUT	Output	Reference output voltage
3	GND	—	Ground

7 Specifications

7.1 Absolute Maximum Ratings

over operating free-air temperature range (unless otherwise noted)⁽¹⁾

	MIN	MAX	UNIT
Supply voltage, V+ to V–		7.0	V
Output short-circuit current ⁽²⁾	Continuous		
Operating temperature	–40	125	°C
Junction temperature		150	°C
Storage temperature, T _{stg}	–65	150	°C

- (1) Stresses beyond those listed under *Absolute Maximum Ratings* may cause permanent damage to the device. These are stress ratings only, which do not imply functional operation of the device at these or any other conditions beyond those indicated under *Recommended Operating Conditions*. Exposure to absolute-maximum-rated conditions for extended periods may affect device reliability.
- (2) Short circuit to ground.

7.2 ESD Ratings

		VALUE	UNIT
V _(ESD)	Electrostatic discharge	Human-body model (HBM), per ANSI/ESDA/JEDEC JS-001 ⁽¹⁾	±4000
		Charged-device model (CDM), per JEDEC specification JESD22-C101 ⁽²⁾	±1500

- (1) JEDEC document JEP155 states that 500-V HBM allows safe manufacturing with a standard ESD control process.
- (2) JEDEC document JEP157 states that 250-V CDM allows safe manufacturing with a standard ESD control process.

7.3 Recommended Operating Conditions

at T_A = 25°C, V_{IN} = 5 V, and I_{LOAD} = 0 mA (unless otherwise noted)

	MIN	NOM	MAX	UNIT
V _{IN} Input voltage	V _{REF} + 0.05 ⁽¹⁾		5.5	V
I _{LOAD} Load current			25	mA
T _A Operating temperature	–40		125	°C

- (1) For I_L > 0, see [Section 7.6](#). Minimum supply voltage for REF3012 is 1.8 V.

7.4 Thermal Information

THERMAL METRIC ⁽¹⁾		REF30xx	UNIT
		DBZ (SOT-23)	
		3 PINS	
R _{θJA}	Junction-to-ambient thermal resistance	297.3	°C/W
R _{θJC(top)}	Junction-to-case (top) thermal resistance	128.5	°C/W
R _{θJB}	Junction-to-board thermal resistance	91.7	°C/W
ψ _{JT}	Junction-to-top characterization parameter	12.8	°C/W
ψ _{JB}	Junction-to-board characterization parameter	90.3	°C/W
R _{θJC(bot)}	Junction-to-case (bottom) thermal resistance	N/A	°C/W

- (1) For more information about traditional and new thermal metrics, see the [Semiconductor and IC Package Thermal Metrics](#) application report.

7.5 Electrical Characteristics

at $T_A = 25^\circ\text{C}$, $V_{IN} = 5\text{ V}$, and $I_{LOAD} = 0\text{ mA}$ (unless otherwise noted)

PARAMETER		TEST CONDITIONS	MIN	TYP	MAX	UNIT
REF3012 (1.25 V)⁽¹⁾						
V_{OUT}	Output voltage		1.2475	1.25	1.2525	V
	Initial accuracy				0.2%	
	Output voltage noise	f = 0.1 Hz to 10 Hz		14		μV_{PP}
		f = 10 Hz to 10 kHz		42		μV_{rms}
	Line regulation	$1.8\text{ V} \leq V_{IN} \leq 5.5\text{ V}$		60	190	$\mu\text{V}/\text{V}$
REF3020 (2.048 V)						
V_{OUT}	Output voltage		2.044	2.048	2.052	V
	Initial accuracy				0.2%	
	Output voltage noise	f = 0.1 Hz to 10 Hz		23		μV_{PP}
		f = 10 Hz to 10 kHz			65	
	Line regulation	$V_{REF} + 50\text{ mV} \leq V_{IN} \leq 5.5\text{ V}$		110	290	$\mu\text{V}/\text{V}$
REF3025 (2.5 V)						
V_{OUT}	Output voltage		2.495	2.50	2.505	V
	Initial accuracy				0.2%	
	Output voltage noise	f = 0.1 Hz to 10 Hz		28		μV_{PP}
		f = 10 Hz to 10 kHz			80	
	Line regulation	$V_{REF} + 50\text{ mV} \leq V_{IN} \leq 5.5\text{ V}$		120	325	$\mu\text{V}/\text{V}$
REF3030 (3.0 V)						
V_{OUT}	Output voltage		2.994	3.0	3.006	V
	Initial accuracy				0.2%	
	Output voltage noise	f = 0.1 Hz to 10 Hz		33		μV_{PP}
		f = 10 Hz to 10 kHz			94	
	Line regulation	$V_{REF} + 50\text{ mV} \leq V_{IN} \leq 5.5\text{ V}$		120	375	$\mu\text{V}/\text{V}$
REF3033 (3.3 V)						
V_{OUT}	Output voltage		3.294	3.30	3.306	V
	Initial accuracy				0.2%	
	Output voltage noise	f = 0.1 Hz to 10 Hz		36		μV_{PP}
		f = 10 Hz to 10 kHz			105	
	Line regulation	$V_{REF} + 50\text{ mV} \leq V_{IN} \leq 5.5\text{ V}$		130	400	$\mu\text{V}/\text{V}$
REF3040 (4.096 V)						
V_{OUT}	Output voltage		4.088	4.096	4.104	V
	Initial accuracy				0.2%	
	Output voltage noise	f = 0.1 Hz to 10 Hz		45		μV_{PP}
		f = 10 Hz to 10 kHz			128	
	Line regulation	$V_{REF} + 50\text{ mV} \leq V_{IN} \leq 5.5\text{ V}$		160	410	$\mu\text{V}/\text{V}$

7.5 Electrical Characteristics (continued)

 at $T_A = 25^\circ\text{C}$, $V_{IN} = 5\text{ V}$, and $I_{LOAD} = 0\text{ mA}$ (unless otherwise noted)

PARAMETER		TEST CONDITIONS	MIN	TYP	MAX	UNIT
REF30xx (REF3012, REF3020, REF3025, REF3030, REF3033, REF3040)						
dV_{OUT}/dT	Output voltage temperature drift ⁽²⁾	$0^\circ\text{C} \leq T_A \leq 70^\circ\text{C}$		20	50	ppm/ $^\circ\text{C}$
		$-30^\circ\text{C} \leq T_A \leq +85^\circ\text{C}$		28	60	
		$-40^\circ\text{C} \leq T_A \leq +85^\circ\text{C}$		30	65	
		$-40^\circ\text{C} \leq T_A \leq +125^\circ\text{C}$		35	75	
Long-term stability		0000h to 1000h		24		ppm
		1000h to 2000h		15		
$\Delta V_{O(\Delta I_L)}$	Load regulation ⁽³⁾	$0\text{ mA} < I_{LOAD} < 25\text{ mA}$, $V_{IN} = V_{REF} + 500\text{ mV}$ ⁽¹⁾		3	100	$\mu\text{V}/\text{mA}$
dT	Thermal hysteresis ⁽⁴⁾			25	100	ppm
$V_{IN} - V_{OUT}$	Dropout voltage			1	50	mV
I_{SC}	Short-circuit current			45		mA
	Turnon settling time	To 0.1% with $C_L = 1\ \mu\text{F}$		120		μs
POWER SUPPLY						
I_Q	Quiescent current			42	50	μA
		$-40^\circ\text{C} \leq T_A \leq +125^\circ\text{C}$			59	

(1) The minimum supply voltage for the REF3012 is 1.8 V.

(2) Box method used to determine over temperature drift.

 (3) Typical value of load regulation reflects measurements using a force and sense contacts; see [Section 8.3.6](#) section.

 (4) Thermal hysteresis procedure explained in more detail in [Section 8.3.2](#) section.

7.6 Typical Characteristics

at $T_A = 25^\circ\text{C}$, $V_{IN} = 5\text{ V}$, and REF3025 used for typical characteristics (unless otherwise noted)

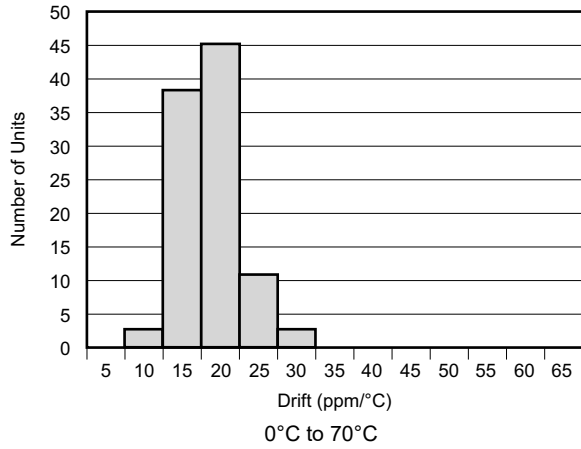

Figure 7-1. Temperature Drift

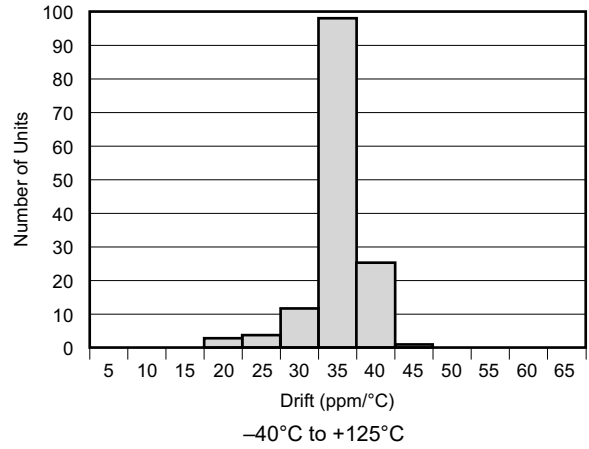

Figure 7-2. Temperature Drift

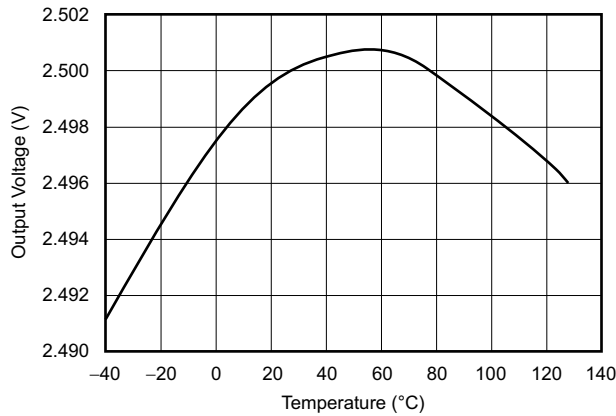

Figure 7-3. Output Voltage vs Temperature

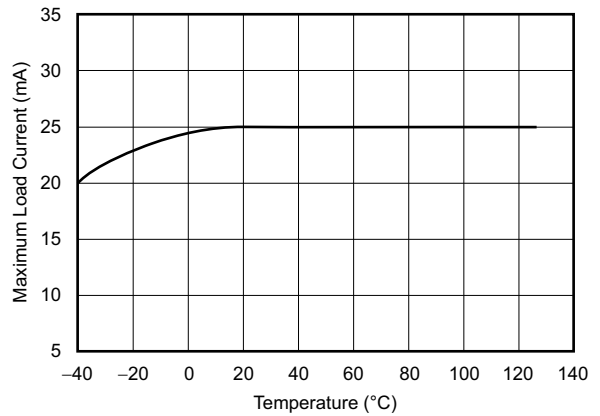

Figure 7-4. Maximum Load Current vs Temperature

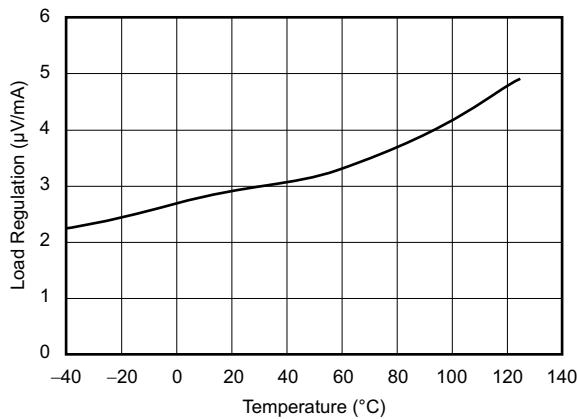

Figure 7-5. Load Regulation vs Temperature

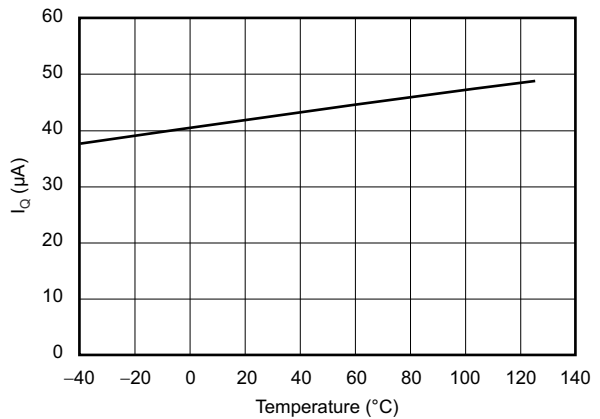

Figure 7-6. Quiescent Current vs Temperature

7.6 Typical Characteristics (continued)

at $T_A = 25^\circ\text{C}$, $V_{IN} = 5\text{ V}$, and REF3025 used for typical characteristics (unless otherwise noted)

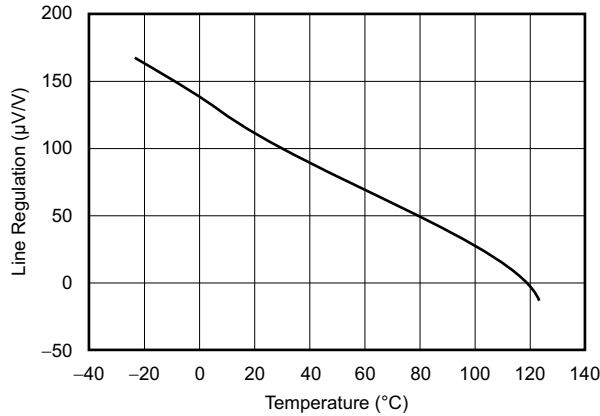

Figure 7-7. Line Regulation vs Temperature

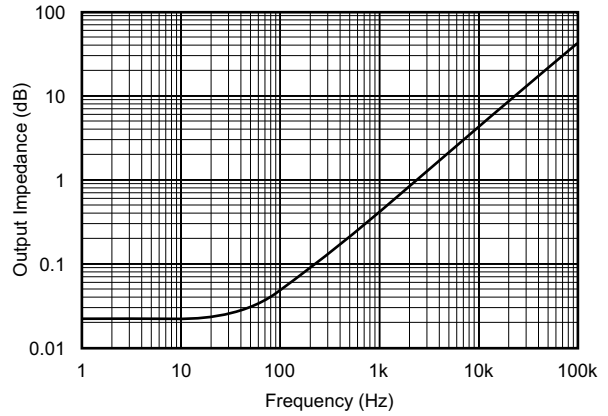

Figure 7-8. Output Impedance vs Frequency

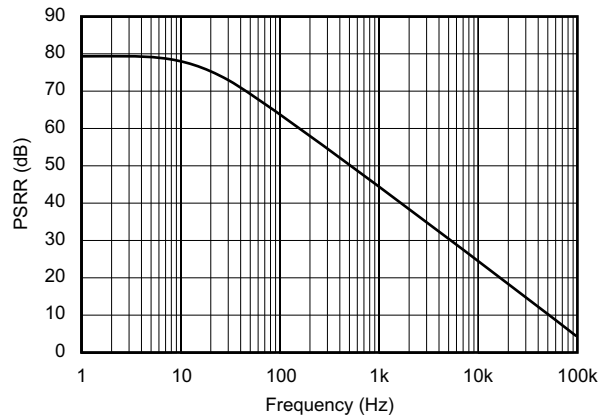

Figure 7-9. Power-Supply Rejection Ratio vs Frequency

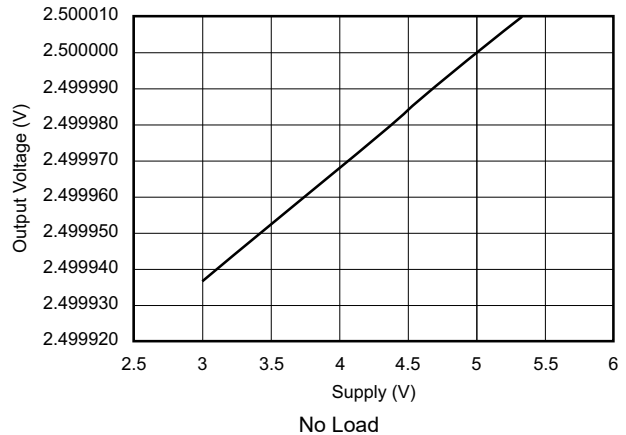

Figure 7-10. Output Voltage vs Supply Voltage

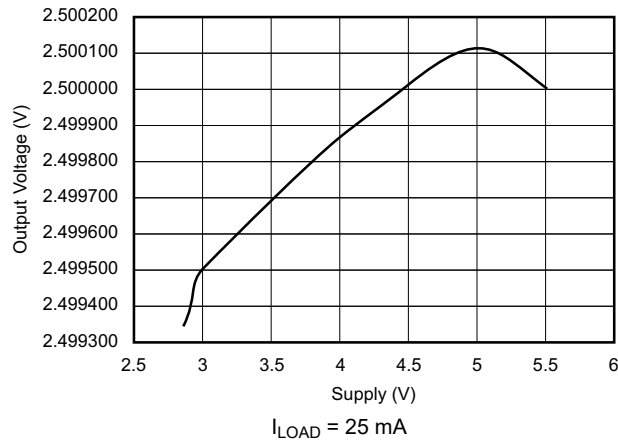

Figure 7-11. Output Voltage vs Supply Voltage

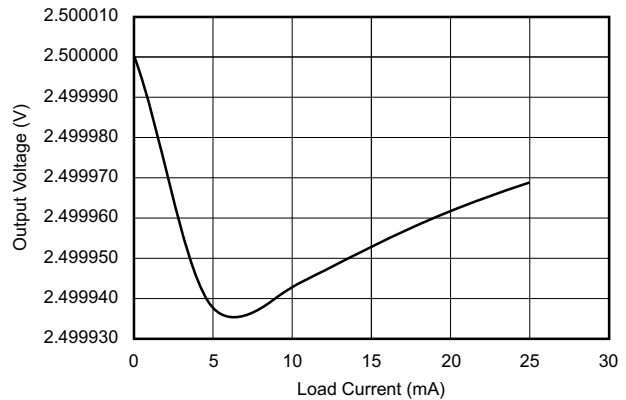
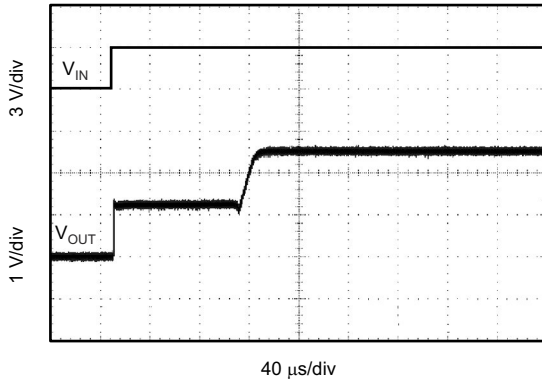

Figure 7-12. Output Voltage vs Load Current

7.6 Typical Characteristics (continued)

at $T_A = 25^\circ\text{C}$, $V_{IN} = 5\text{ V}$, and REF3025 used for typical characteristics (unless otherwise noted)



$C_L = 0$, 3-V startup
Figure 7-13. Step Response

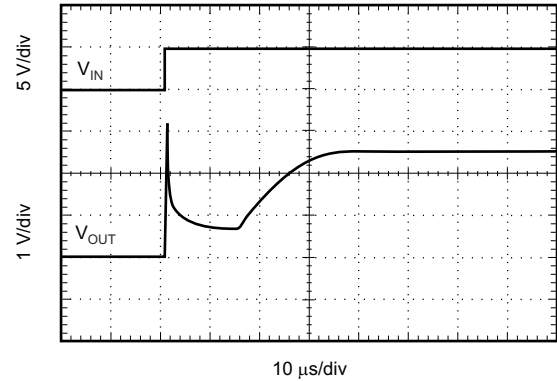

$C_L = 0$, 5-V startup
Figure 7-14. Step Response

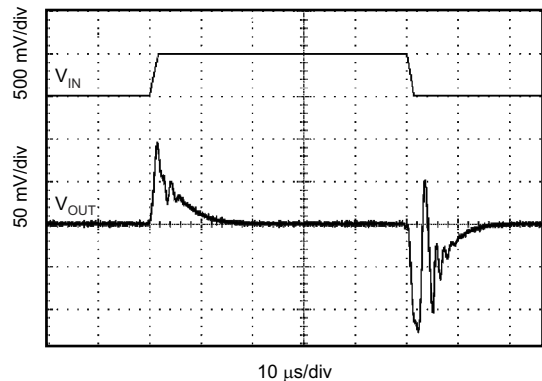
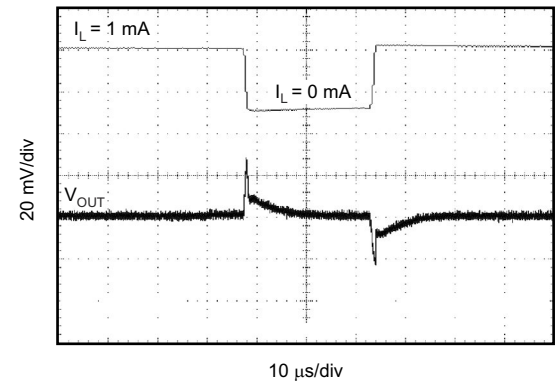
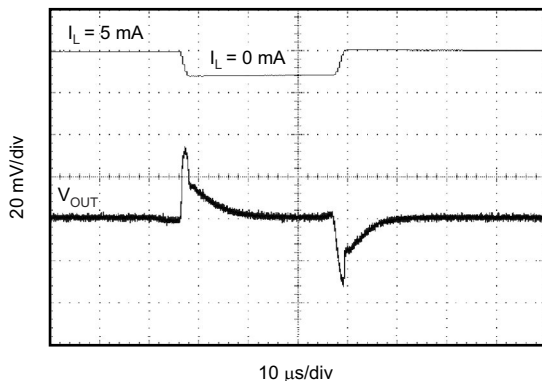

Figure 7-15. Line Transient Response



$C_L = 0$
Figure 7-16. 0-mA to 1-mA Load Transient



$C_L = 0$
Figure 7-17. 0-mA to 5-mA Load Transient

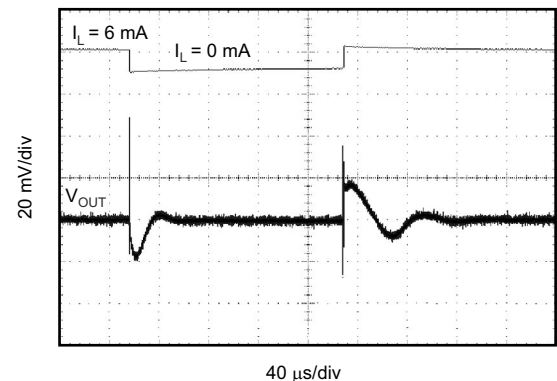

$C_L = 1\ \mu\text{F}$
Figure 7-18. 1-mA to 6-mA Load Transient

7.6 Typical Characteristics (continued)

at $T_A = 25^\circ\text{C}$, $V_{IN} = 5\text{ V}$, and REF3025 used for typical characteristics (unless otherwise noted)

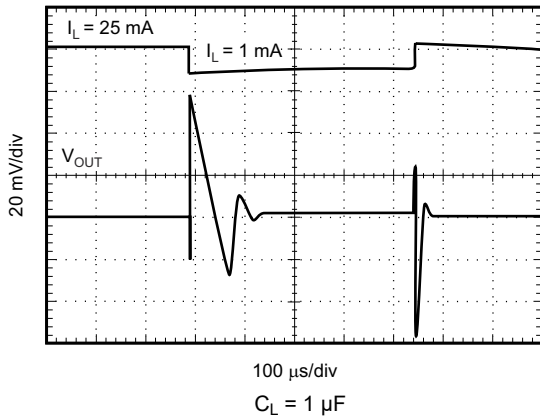

Figure 7-19. 1-mA to 25-mA Load Transient

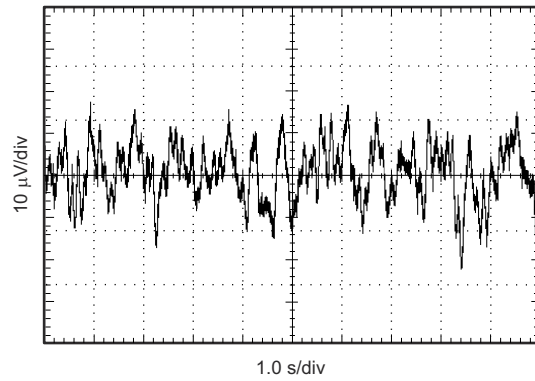

Figure 7-20. 0.1-Hz to 10-Hz Noise

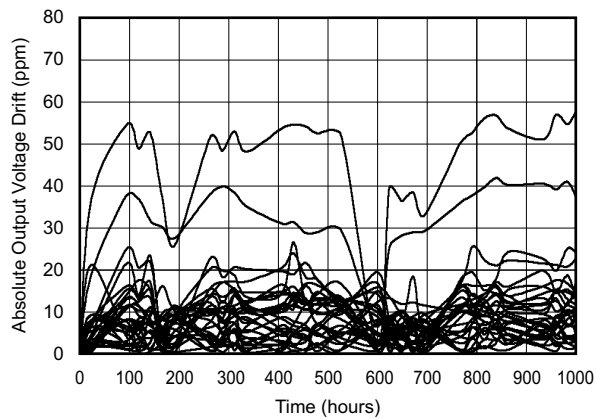

Figure 7-21. Long-Term Stability: 0 to 1000 Hours

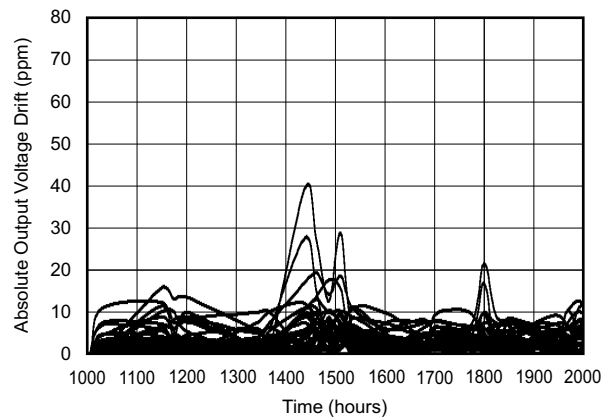

Figure 7-22. Long-Term Stability: 1000 to 2000 Hours

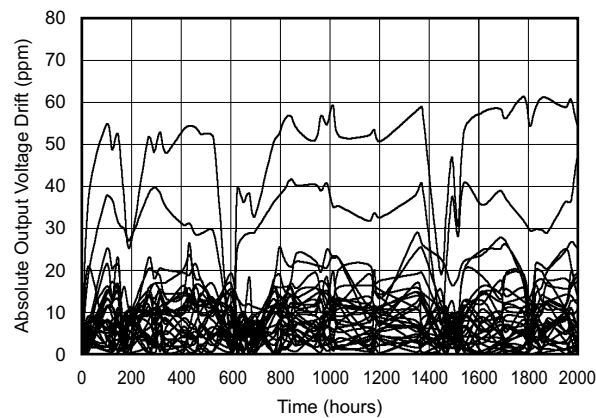

Figure 7-23. Long-Term Stability: 0 to 2000 Hours

8 Detailed Description

8.1 Overview

The REF30xx is a series, CMOS, precision bandgap voltage reference. Its basic topology is shown in the [Section 8.2](#) section. Transistors Q_1 and Q_2 are biased so that the current density of Q_1 is greater than that of Q_2 . The difference of the two base-emitter voltages, $V_{be1} - V_{be2}$, has a positive temperature coefficient and is forced across resistor R_1 . This voltage is gained up and added to the base-emitter voltage of Q_2 , which has a negative coefficient. The resulting output voltage is virtually independent of temperature. The curvature of the bandgap voltage, as shown in [Figure 7-3](#), is due to the slightly nonlinear temperature coefficient of the base-emitter voltage of Q_2 .

8.2 Functional Block Diagram

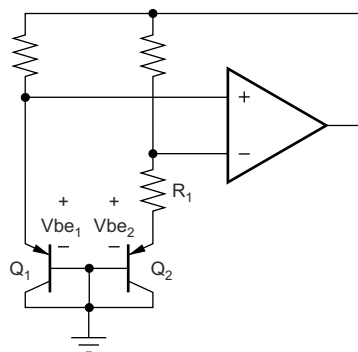

Copyright © 2016, Texas Instruments Incorporated

8.3 Feature Description

8.3.1 Supply Voltage

The REF30xx family of references features an extremely low dropout voltage. With the exception of the REF3012, which has a minimum supply requirement of 1.8 V, the REF30xx can be operated with a supply of only 1 mV above the output voltage in an unloaded condition. For loaded conditions, a typical dropout voltage versus load is shown on the front page.

The REF30xx features a low quiescent current that is extremely stable over changes in both temperature and supply. The typical room temperature quiescent current is 42 μ A, and the maximum quiescent current over temperature is just 59 μ A. Additionally, the quiescent current typically changes less than 2.5 μ A over the entire supply range, as shown in [Figure 8-1](#).

Supply voltages below the specified levels can cause the REF30xx to momentarily draw currents greater than the typical quiescent current. Use a power supply with a fast rising edge and low output impedance to easily prevent this issue.

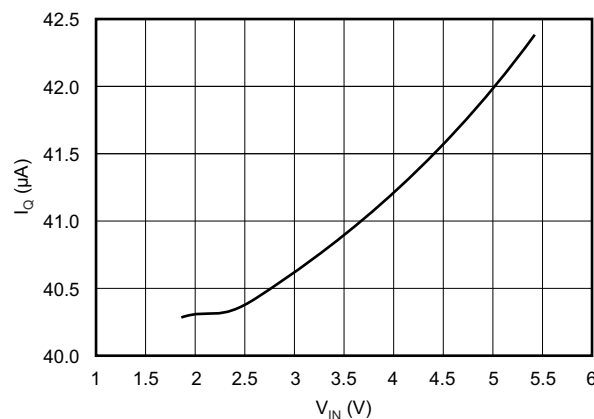

Figure 8-1. Supply Current vs Supply Voltage

8.3.2 Thermal Hysteresis

Thermal hysteresis for the REF30xx is defined as the change in output voltage after operating the device at 25°C, cycling the device through the specified temperature range, and returning to 25°C, and can be expressed as shown in Equation 1:

$$V_{\text{HYST}} = \left(\frac{\text{abs}|V_{\text{PRE}} - V_{\text{POST}}|}{V_{\text{NOM}}} \right) \cdot 10^6 \text{ (ppm)} \quad (1)$$

where

- V_{HYST} = Calculated hysteresis
- V_{PRE} = Output voltage measured at 25°C pretemperature cycling
- V_{POST} = Output voltage measured when device has been operated at 25°C, cycled through specified range of –40°C to +125°C, and returned to operation at 25°C.

8.3.3 Temperature Drift

The REF30xx exhibits minimal drift error, defined as the change in output voltage over varying temperature. Using the *box* method of drift measurement, the REF30xx features a typical drift coefficient of 20 ppm from 0°C to 70°C, the primary temperature range of use for many applications. For industrial temperature ranges of –40°C to +125°C, the REF30xx family drift increases to a typical value of 50 ppm.

8.3.4 Noise Performance

The REF30xx generates noise less than 50 μV_{PP} between frequencies of 0.1 Hz to 10 Hz, and can be seen in Figure 7-20 The noise voltage of the REF30xx increases with output voltage and operating temperature. Additional filtering may be used to improve output noise levels; however, ensure the output impedance does not degrade AC performance.

8.3.5 Long-Term Stability

Long-term stability refers to the change of the output voltage of a reference over a period of months or years. This effect lessens as time progresses as is apparent by the long-term stability curves. The typical drift value for the REF30xx is 24 ppm from 0 hours to 1000 hours, and 15 ppm from 1000 hours to 2000 hours. This parameter is characterized by measuring 30 units at regular intervals for a period of 2000 hours.

8.3.6 Load Regulation

Load regulation is defined as the change in output voltage as a result of changes in load current. Load regulation for the REF30xx is measured using force and sense contacts as shown in Figure 8-2. The force and sense lines tied to the contact area of the output pin reduce the impact of contact and trace resistance, resulting in accurate measurement of the load regulation contributed solely by the REF30xx. For applications requiring improved load regulation, use force and sense lines.

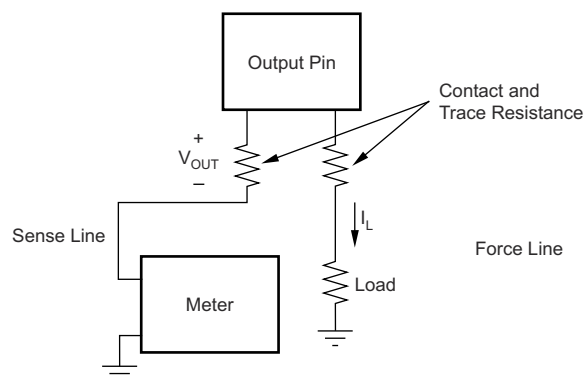

Copyright © 2016, Texas Instruments Incorporated

Figure 8-2. Accurate Load Regulation of REF30xx

8.4 Device Functional Modes

8.4.1 Negative Reference Voltage

For applications requiring a negative and positive reference voltage, the OPA703 and REF30xx can be used to provide a dual-supply reference from a ± 5 -V supply. Figure 8-3 shows the REF3025 used to provide a ± 2.5 -V supply reference voltage. The low offset voltage and low drift of the OPA703 complement the low drift performance of the REF30xx to provide an accurate solution for split-supply applications.

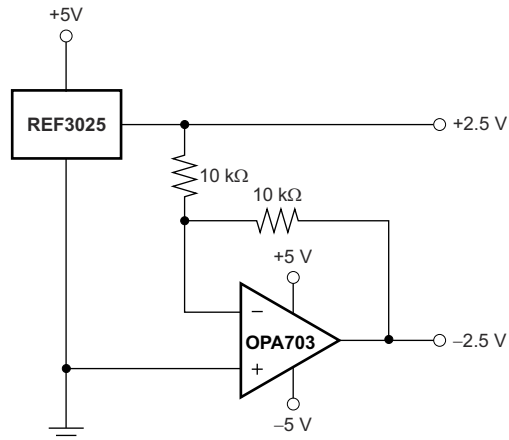

Copyright © 2016, Texas Instruments Incorporated

Figure 8-3. REF3025 Combined With OPA703 to Create Positive and Negative Reference Voltages.

8.4.2 Data Acquisition

Often data acquisition systems require stable voltage references to maintain necessary accuracy. The REF30xx family features stability and a wide range of voltages suitable for most microcontrollers and data converters. Figure 8-4 and Figure 8-5 show two basic data acquisition systems.

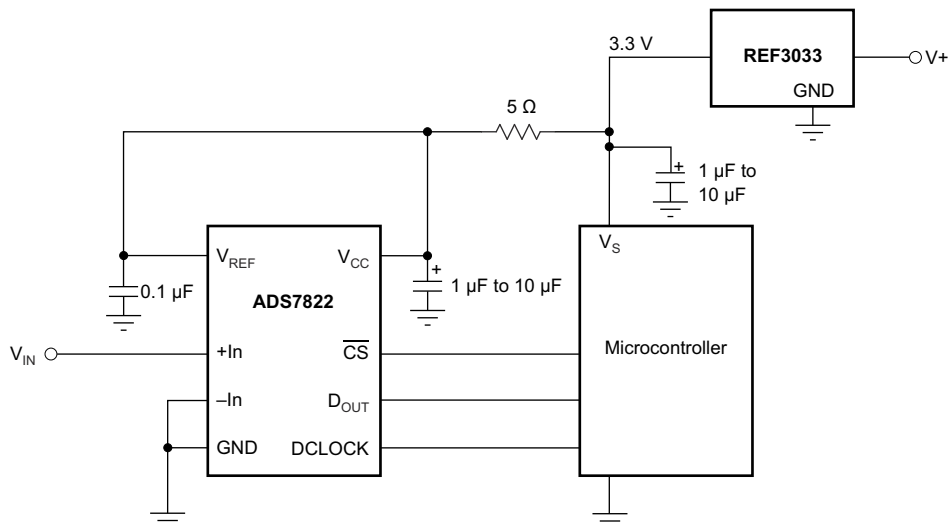

Copyright © 2016, Texas Instruments Incorporated

Figure 8-4. Basic Data Acquisition System 1

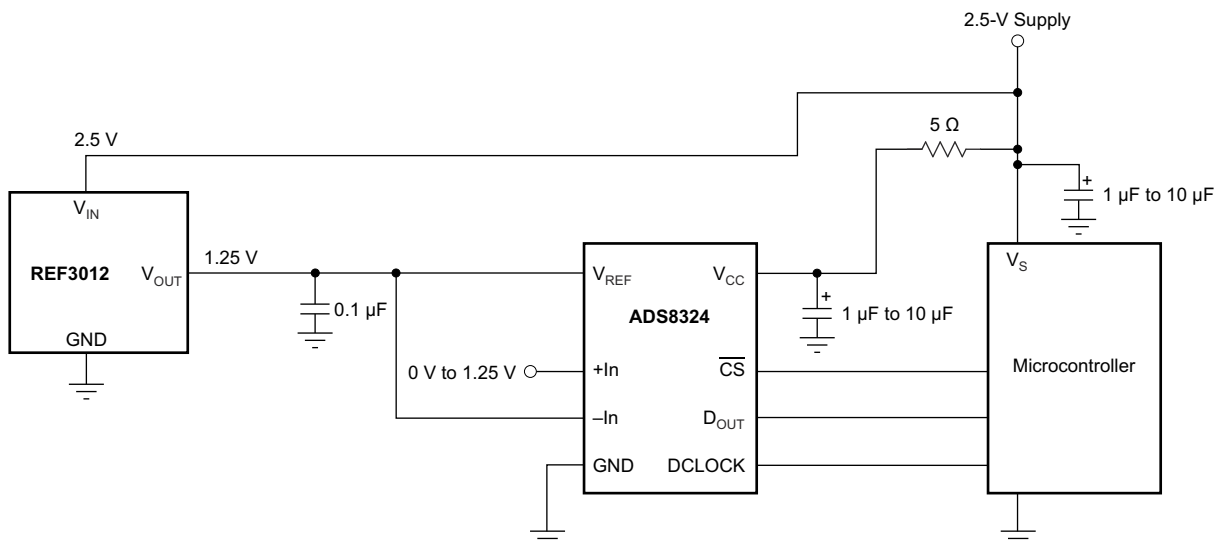

Copyright © 2016, Texas Instruments Incorporated

Figure 8-5. Basic Data Acquisition System 2

9 Application and Implementation

Note

Information in the following applications sections is not part of the TI component specification, and TI does not warrant its accuracy or completeness. TI's customers are responsible for determining suitability of components for their purposes, as well as validating and testing their design implementation to confirm system functionality.

9.1 Application Information

For normal operation, the REF30xx does not require a capacitor on the output. If a capacitive load is connected, take special care when using low equivalent series resistance (ESR) capacitors and high capacitance. This precaution is especially true for low-output voltage devices; therefore, for the REF3012 use a low-ESR capacitance of 10 μF or less. [Figure 9-1](#) shows the typical connections required for operation of the REF30xx. A supply bypass capacitor of 0.47 μF is always recommended.

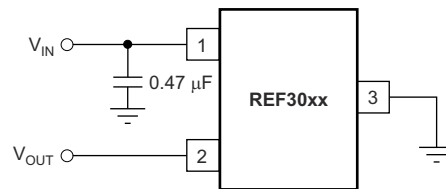

Copyright © 2016, Texas Instruments Incorporated

Figure 9-1. Typical Connections for Operating REF30xx

9.2 Typical Application

[Figure 9-2](#) shows a low-power reference and conditioning circuit. This circuit attenuates and level-shifts a bipolar input voltage within the proper input range of a single-supply low power 16-Bit $\Delta\Sigma$ ADC, such as the one inside the [MSP430](#) or other similar single-supply ADCs. Precision reference circuits are used to level-shift the input signal, provide the ADC reference voltage and to create a well-regulated supply voltage for the low-power analog circuitry. A low-power, zero-drift, op-amp circuit is used to attenuate and level-shift the input signal.

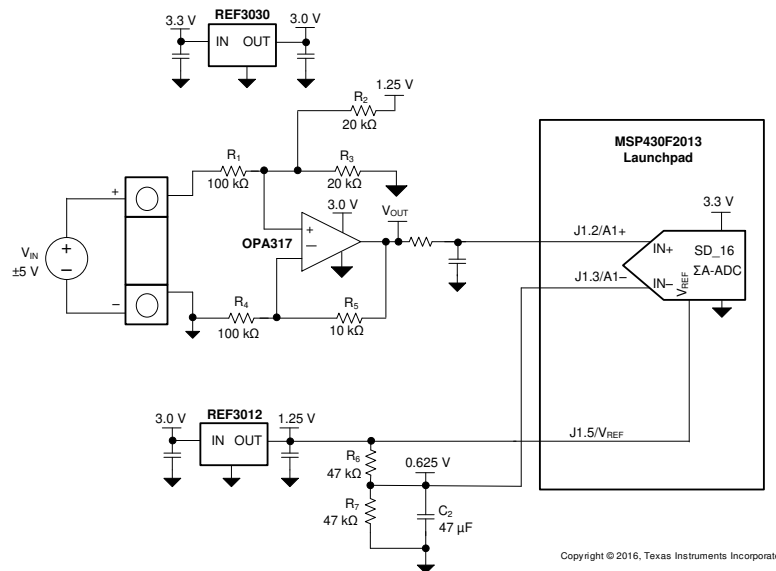

Copyright © 2016, Texas Instruments Incorporated

Figure 9-2. Low-Power Reference and Bipolar Voltage Conditioning Circuit for Low-Power ADCs

9.2.1 Design Requirements

- Supply Voltage: 3.3 V
- Maximum Input Voltage: ± 6 V
- Specified Input Voltage: ± 5 V
- ADC Reference Voltage: 1.25 V

The goal for this design is to accurately condition a ± 5 -V bipolar input voltage into a voltage suitable for conversion by a low-voltage ADC with a 1.25-V reference voltage, V_{REF} , and an input voltage range of $V_{REF} / 2$. The circuit should function with reduced performance over a wider input range of at least ± 6 V to allow for easier protection of overvoltage conditions.

9.2.2 Detailed Design Procedure

Figure 9-2 depicts a simplified schematic for this design showing the MSP430 ADC inputs and full input conditioning circuitry. The ADC is configured for a bipolar measurement where final conversion result is the differential voltage between the voltage at the positive and negative ADC inputs. The bipolar, GND-referenced input signal must be level-shifted and attenuated by the op amp so that the output is biased to $V_{REF} / 2$ and has a differential voltage that is within the $\pm V_{REF} / 2$ input range of the ADC.

9.2.3 Application Curves

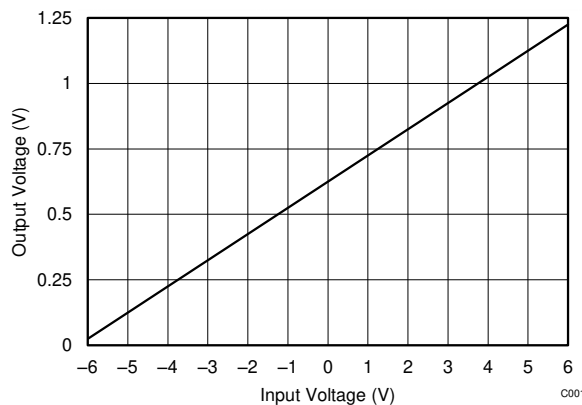

Figure 9-3. OPA317 Output Voltage vs Input Voltage

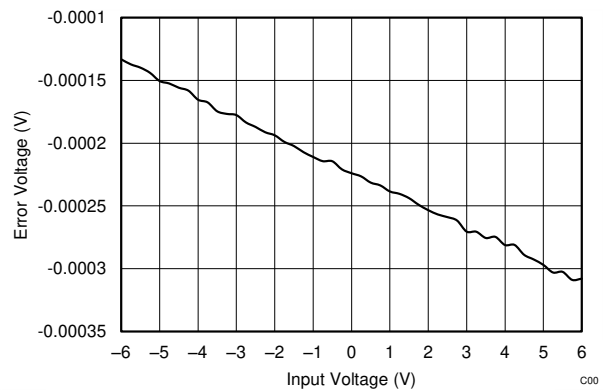

Figure 9-4. OPA317 Output Voltage Error vs Input Voltage

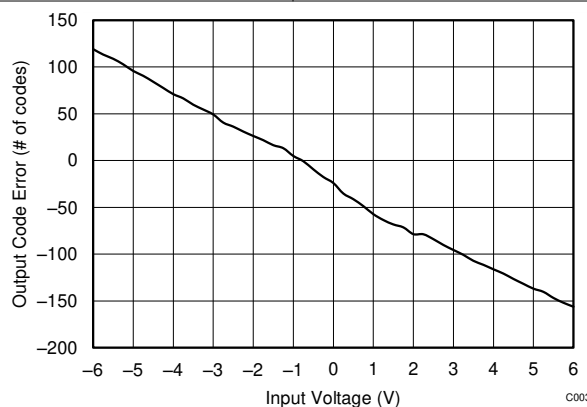

Figure 9-5. Output Code Error vs Input Voltage

10 Power Supply Recommendations

The REF30xx family of references feature an extremely low-dropout voltage. These references can be operated with a supply of only 50 mV above the output voltage. For loaded reference conditions, a typical dropout voltage versus load is shown in the front page plot, [Figure 3-1](#). Use a supply bypass capacitor greater than 0.47 μF .

11 Layout

11.1 Layout Guidelines

[Figure 11-1](#) illustrates an example of a printed-circuit board (PCB) layout using the REF30xx. Some key considerations are:

- Connect low-ESR, 0.1- μF ceramic bypass capacitors at V_{IN} of the REF30xx
- Decouple other active devices in the system per the device specifications
- Use a solid ground plane to help distribute heat and reduces electromagnetic interference (EMI) noise pickup
- Place the external components as close to the device as possible. This configuration prevents parasitic errors (such as the Seebeck effect) from occurring
- Minimize trace length between the reference and bias connections to the INA and ADC to reduce noise pickup
- Do not run sensitive analog traces in parallel with digital traces. Avoid crossing digital and analog traces if possible, and only make perpendicular crossings when absolutely necessary

11.2 Layout Example

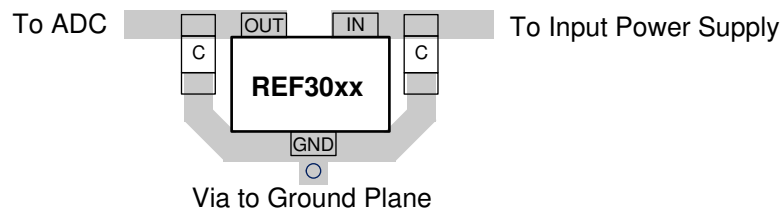

Figure 11-1. Layout Example

12 Device and Documentation Support

12.1 Documentation Support

12.1.1 Related Documentation

[CMOS, Rail-to-Rail, I/O Operational Amplifiers](#) (SBOS180)

[REF29xx 100 ppm/°C, 50 µA in 3-Pin SOT-23 CMOS Voltage Reference](#) (SBVS033)

12.2 Related Links

Table 12-1 lists quick access links. Categories include technical documents, support and community resources, tools and software, and quick access to sample or buy.

Table 12-1. Related Links

PARTS	PRODUCT FOLDER	SAMPLE & BUY	TECHNICAL DOCUMENTS	TOOLS & SOFTWARE	SUPPORT & COMMUNITY
REF3012	Click here	Click here	Click here	Click here	Click here
REF3020	Click here	Click here	Click here	Click here	Click here
REF3025	Click here	Click here	Click here	Click here	Click here
REF3030	Click here	Click here	Click here	Click here	Click here
REF3033	Click here	Click here	Click here	Click here	Click here
REF3040	Click here	Click here	Click here	Click here	Click here

12.3 Receiving Notification of Documentation Updates

To receive notification of documentation updates, navigate to the device product folder on ti.com. Click on *Subscribe to updates* to register and receive a weekly digest of any product information that has changed. For change details, review the revision history included in any revised document.

12.4 Support Resources

[TI E2E™ support forums](#) are an engineer's go-to source for fast, verified answers and design help — straight from the experts. Search existing answers or ask your own question to get the quick design help you need.

Linked content is provided "AS IS" by the respective contributors. They do not constitute TI specifications and do not necessarily reflect TI's views; see TI's [Terms of Use](#).

12.5 Trademarks

TI E2E™ is a trademark of Texas Instruments.
 All trademarks are the property of their respective owners.

12.6 Electrostatic Discharge Caution



This integrated circuit can be damaged by ESD. Texas Instruments recommends that all integrated circuits be handled with appropriate precautions. Failure to observe proper handling and installation procedures can cause damage.

ESD damage can range from subtle performance degradation to complete device failure. Precision integrated circuits may be more susceptible to damage because very small parametric changes could cause the device not to meet its published specifications.

12.7 Glossary

[TI Glossary](#) This glossary lists and explains terms, acronyms, and definitions.

13 Mechanical, Packaging, and Orderable Information

The following pages include mechanical packaging and orderable information. This information is the most current data available for the designated devices. This data is subject to change without notice and revision of this document. For browser-based versions of this data sheet, refer to the left-hand navigation.

PACKAGING INFORMATION

Orderable Device	Status (1)	Package Type	Package Drawing	Pins	Package Qty	Eco Plan (2)	Lead finish/ Ball material (6)	MSL Peak Temp (3)	Op Temp (°C)	Device Marking (4/5)	Samples
REF3012AIDBZR	ACTIVE	SOT-23	DBZ	3	3000	RoHS & Green	NIPDAUAG	Level-1-260C-UNLIM	-40 to 125	R30A	Samples
REF3012AIDBZT	ACTIVE	SOT-23	DBZ	3	250	RoHS & Green	NIPDAUAG	Level-1-260C-UNLIM	-40 to 125	R30A	Samples
REF3020AIDBZR	ACTIVE	SOT-23	DBZ	3	3000	RoHS & Green	NIPDAUAG	Level-1-260C-UNLIM	-40 to 125	R30B	Samples
REF3020AIDBZT	ACTIVE	SOT-23	DBZ	3	250	RoHS & Green	NIPDAUAG	Level-1-260C-UNLIM	-40 to 125	R30B	Samples
REF3025AIDBZR	ACTIVE	SOT-23	DBZ	3	3000	RoHS & Green	NIPDAUAG	Level-1-260C-UNLIM	-40 to 125	R30C	Samples
REF3025AIDBZT	ACTIVE	SOT-23	DBZ	3	250	RoHS & Green	NIPDAUAG	Level-1-260C-UNLIM	-40 to 125	R30C	Samples
REF3030AIDBZR	ACTIVE	SOT-23	DBZ	3	3000	RoHS & Green	NIPDAUAG	Level-1-260C-UNLIM	-40 to 125	R30F	Samples
REF3030AIDBZT	ACTIVE	SOT-23	DBZ	3	250	RoHS & Green	NIPDAUAG	Level-1-260C-UNLIM	-40 to 125	R30F	Samples
REF3033AIDBZR	ACTIVE	SOT-23	DBZ	3	3000	RoHS & Green	NIPDAUAG	Level-1-260C-UNLIM	-40 to 125	R30D	Samples
REF3033AIDBZT	ACTIVE	SOT-23	DBZ	3	250	RoHS & Green	NIPDAUAG	Level-1-260C-UNLIM	-40 to 125	R30D	Samples
REF3040AIDBZR	ACTIVE	SOT-23	DBZ	3	3000	RoHS & Green	NIPDAUAG	Level-1-260C-UNLIM	-40 to 125	R30E	Samples
REF3040AIDBZT	ACTIVE	SOT-23	DBZ	3	250	RoHS & Green	NIPDAUAG	Level-1-260C-UNLIM	-40 to 125	R30E	Samples

(1) The marketing status values are defined as follows:

ACTIVE: Product device recommended for new designs.

LIFEBUY: TI has announced that the device will be discontinued, and a lifetime-buy period is in effect.

NRND: Not recommended for new designs. Device is in production to support existing customers, but TI does not recommend using this part in a new design.

PREVIEW: Device has been announced but is not in production. Samples may or may not be available.

OBSELETE: TI has discontinued the production of the device.

(2) **RoHS:** TI defines "RoHS" to mean semiconductor products that are compliant with the current EU RoHS requirements for all 10 RoHS substances, including the requirement that RoHS substance do not exceed 0.1% by weight in homogeneous materials. Where designed to be soldered at high temperatures, "RoHS" products are suitable for use in specified lead-free processes. TI may reference these types of products as "Pb-Free".

RoHS Exempt: TI defines "RoHS Exempt" to mean products that contain lead but are compliant with EU RoHS pursuant to a specific EU RoHS exemption.

Green: TI defines "Green" to mean the content of Chlorine (Cl) and Bromine (Br) based flame retardants meet JS709B low halogen requirements of <=1000ppm threshold. Antimony trioxide based flame retardants must also meet the <=1000ppm threshold requirement.

- (3) MSL, Peak Temp. - The Moisture Sensitivity Level rating according to the JEDEC industry standard classifications, and peak solder temperature.
- (4) There may be additional marking, which relates to the logo, the lot trace code information, or the environmental category on the device.
- (5) Multiple Device Markings will be inside parentheses. Only one Device Marking contained in parentheses and separated by a "~" will appear on a device. If a line is indented then it is a continuation of the previous line and the two combined represent the entire Device Marking for that device.
- (6) Lead finish/Ball material - Orderable Devices may have multiple material finish options. Finish options are separated by a vertical ruled line. Lead finish/Ball material values may wrap to two lines if the finish value exceeds the maximum column width.

Important Information and Disclaimer:The information provided on this page represents TI's knowledge and belief as of the date that it is provided. TI bases its knowledge and belief on information provided by third parties, and makes no representation or warranty as to the accuracy of such information. Efforts are underway to better integrate information from third parties. TI has taken and continues to take reasonable steps to provide representative and accurate information but may not have conducted destructive testing or chemical analysis on incoming materials and chemicals. TI and TI suppliers consider certain information to be proprietary, and thus CAS numbers and other limited information may not be available for release.

In no event shall TI's liability arising out of such information exceed the total purchase price of the TI part(s) at issue in this document sold by TI to Customer on an annual basis.

OTHER QUALIFIED VERSIONS OF REF3033 :

- Automotive : [REF3033-Q1](#)

NOTE: Qualified Version Definitions:

- Automotive - Q100 devices qualified for high-reliability automotive applications targeting zero defects

TAPE AND REEL INFORMATION



QUADRANT ASSIGNMENTS FOR PIN 1 ORIENTATION IN TAPE

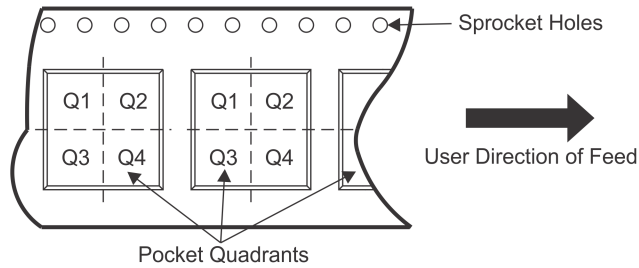

*All dimensions are nominal

Device	Package Type	Package Drawing	Pins	SPQ	Reel Diameter (mm)	Reel Width W1 (mm)	A0 (mm)	B0 (mm)	K0 (mm)	P1 (mm)	W (mm)	Pin1 Quadrant
REF3012AIDBZR	SOT-23	DBZ	3	3000	179.0	8.4	3.15	2.95	1.22	4.0	8.0	Q3
REF3012AIDBZT	SOT-23	DBZ	3	250	179.0	8.4	3.15	2.95	1.22	4.0	8.0	Q3
REF3020AIDBZR	SOT-23	DBZ	3	3000	179.0	8.4	3.15	2.95	1.22	4.0	8.0	Q3
REF3020AIDBZT	SOT-23	DBZ	3	250	179.0	8.4	3.15	2.95	1.22	4.0	8.0	Q3
REF3025AIDBZR	SOT-23	DBZ	3	3000	180.0	8.4	3.15	2.95	1.22	4.0	8.0	Q3
REF3025AIDBZT	SOT-23	DBZ	3	250	179.0	8.4	3.15	2.95	1.22	4.0	8.0	Q3
REF3030AIDBZR	SOT-23	DBZ	3	3000	179.0	8.4	3.15	2.95	1.22	4.0	8.0	Q3
REF3030AIDBZT	SOT-23	DBZ	3	250	179.0	8.4	3.15	2.95	1.22	4.0	8.0	Q3
REF3033AIDBZR	SOT-23	DBZ	3	3000	179.0	8.4	3.15	2.95	1.22	4.0	8.0	Q3
REF3033AIDBZT	SOT-23	DBZ	3	250	179.0	8.4	3.15	2.95	1.22	4.0	8.0	Q3
REF3040AIDBZR	SOT-23	DBZ	3	3000	179.0	8.4	3.15	2.95	1.22	4.0	8.0	Q3
REF3040AIDBZT	SOT-23	DBZ	3	250	179.0	8.4	3.15	2.95	1.22	4.0	8.0	Q3

TAPE AND REEL BOX DIMENSIONS

*All dimensions are nominal

Device	Package Type	Package Drawing	Pins	SPQ	Length (mm)	Width (mm)	Height (mm)
REF3012AIDBZR	SOT-23	DBZ	3	3000	200.0	183.0	25.0
REF3012AIDBZT	SOT-23	DBZ	3	250	200.0	183.0	25.0
REF3020AIDBZR	SOT-23	DBZ	3	3000	200.0	183.0	25.0
REF3020AIDBZT	SOT-23	DBZ	3	250	200.0	183.0	25.0
REF3025AIDBZR	SOT-23	DBZ	3	3000	200.0	183.0	25.0
REF3025AIDBZT	SOT-23	DBZ	3	250	200.0	183.0	25.0
REF3030AIDBZR	SOT-23	DBZ	3	3000	200.0	183.0	25.0
REF3030AIDBZT	SOT-23	DBZ	3	250	200.0	183.0	25.0
REF3033AIDBZR	SOT-23	DBZ	3	3000	200.0	183.0	25.0
REF3033AIDBZT	SOT-23	DBZ	3	250	200.0	183.0	25.0
REF3040AIDBZR	SOT-23	DBZ	3	3000	200.0	183.0	25.0
REF3040AIDBZT	SOT-23	DBZ	3	250	200.0	183.0	25.0

DBZ0003A



PACKAGE OUTLINE

SOT-23 - 1.12 mm max height

SMALL OUTLINE TRANSISTOR

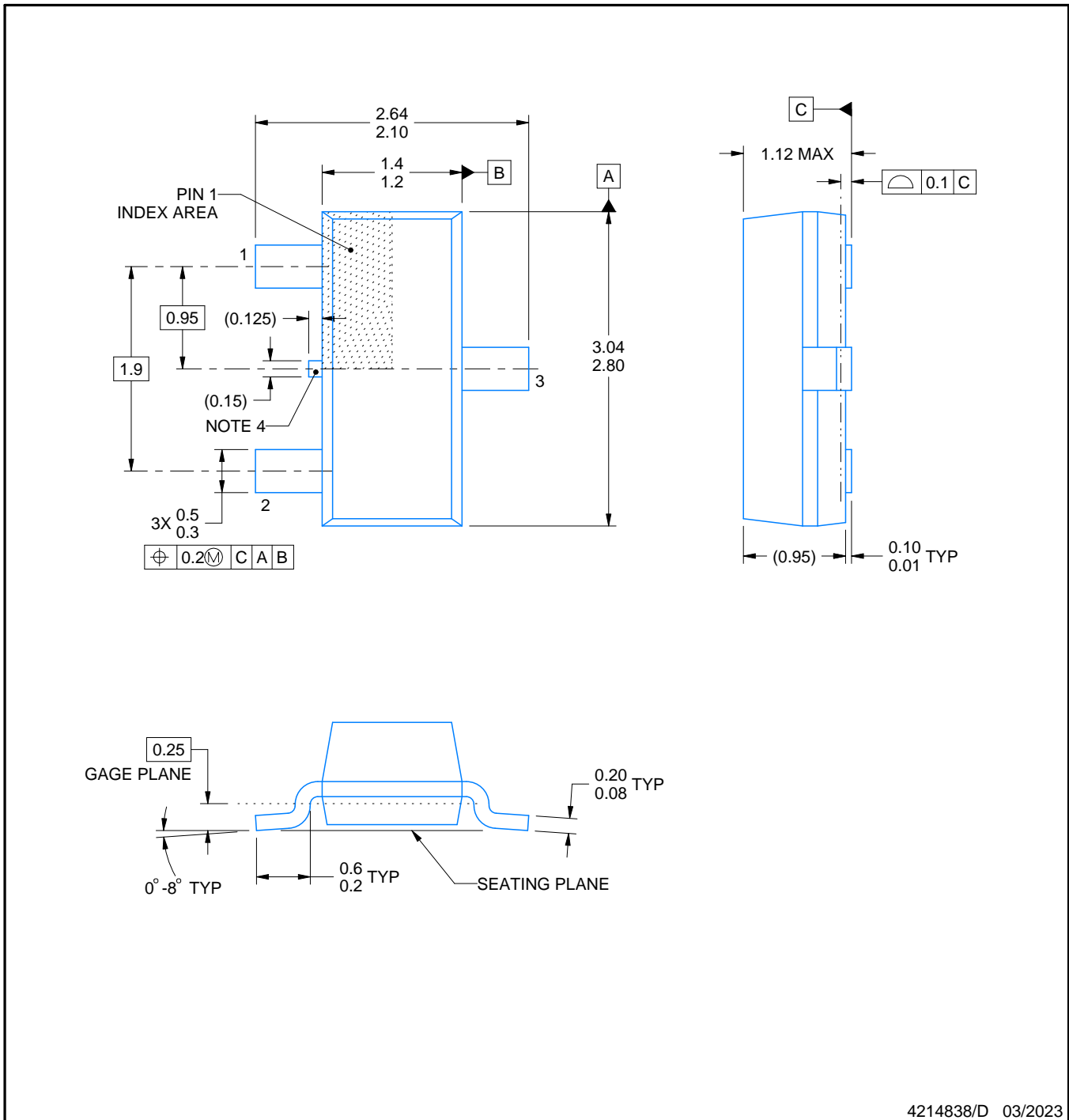

4214838/D 03/2023

NOTES:

1. All linear dimensions are in millimeters. Any dimensions in parenthesis are for reference only. Dimensioning and tolerancing per ASME Y14.5M.
2. This drawing is subject to change without notice.
3. Reference JEDEC registration TO-236, except minimum foot length.
4. Support pin may differ or may not be present.

EXAMPLE BOARD LAYOUT

DBZ0003A

SOT-23 - 1.12 mm max height

SMALL OUTLINE TRANSISTOR

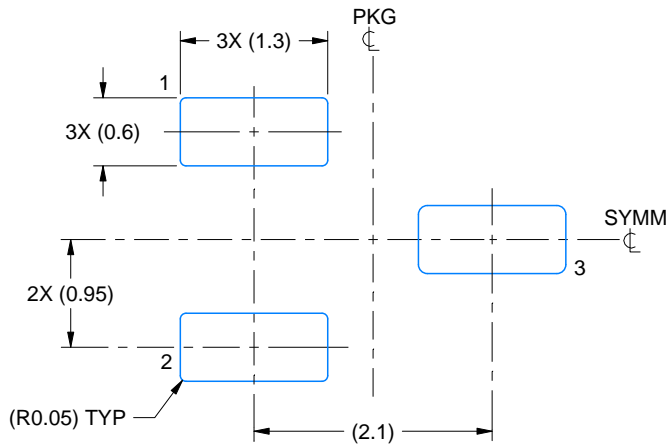

LAND PATTERN EXAMPLE
SCALE:15X

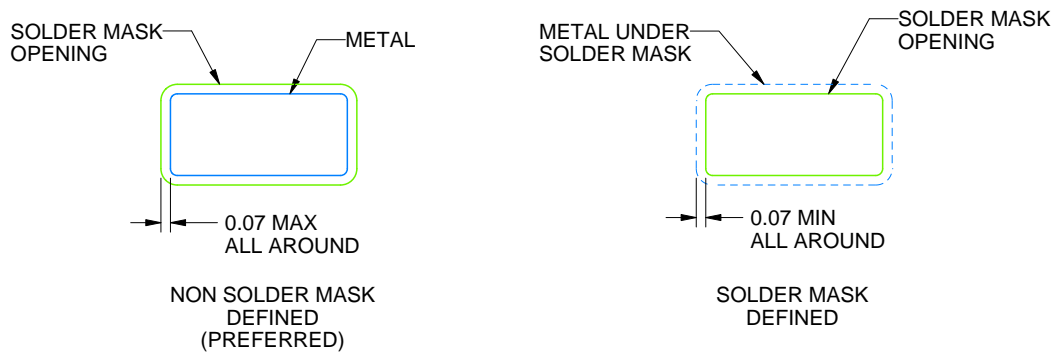

SOLDER MASK DETAILS

4214838/D 03/2023

NOTES: (continued)

- 4. Publication IPC-7351 may have alternate designs.
- 5. Solder mask tolerances between and around signal pads can vary based on board fabrication site.

EXAMPLE STENCIL DESIGN

DBZ0003A

SOT-23 - 1.12 mm max height

SMALL OUTLINE TRANSISTOR

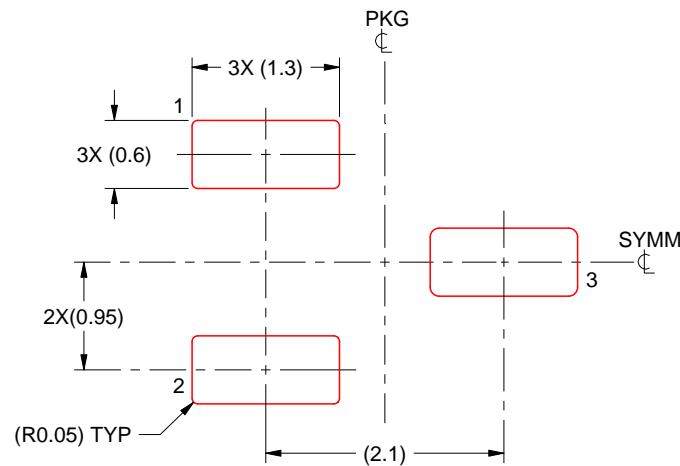

SOLDER PASTE EXAMPLE
BASED ON 0.125 THICK STENCIL
SCALE:15X

4214838/D 03/2023

NOTES: (continued)

6. Laser cutting apertures with trapezoidal walls and rounded corners may offer better paste release. IPC-7525 may have alternate design recommendations.
7. Board assembly site may have different recommendations for stencil design.

IMPORTANT NOTICE AND DISCLAIMER

TI PROVIDES TECHNICAL AND RELIABILITY DATA (INCLUDING DATA SHEETS), DESIGN RESOURCES (INCLUDING REFERENCE DESIGNS), APPLICATION OR OTHER DESIGN ADVICE, WEB TOOLS, SAFETY INFORMATION, AND OTHER RESOURCES "AS IS" AND WITH ALL FAULTS, AND DISCLAIMS ALL WARRANTIES, EXPRESS AND IMPLIED, INCLUDING WITHOUT LIMITATION ANY IMPLIED WARRANTIES OF MERCHANTABILITY, FITNESS FOR A PARTICULAR PURPOSE OR NON-INFRINGEMENT OF THIRD PARTY INTELLECTUAL PROPERTY RIGHTS.

These resources are intended for skilled developers designing with TI products. You are solely responsible for (1) selecting the appropriate TI products for your application, (2) designing, validating and testing your application, and (3) ensuring your application meets applicable standards, and any other safety, security, regulatory or other requirements.

These resources are subject to change without notice. TI grants you permission to use these resources only for development of an application that uses the TI products described in the resource. Other reproduction and display of these resources is prohibited. No license is granted to any other TI intellectual property right or to any third party intellectual property right. TI disclaims responsibility for, and you will fully indemnify TI and its representatives against, any claims, damages, costs, losses, and liabilities arising out of your use of these resources.

TI's products are provided subject to [TI's Terms of Sale](#) or other applicable terms available either on [ti.com](https://www.ti.com) or provided in conjunction with such TI products. TI's provision of these resources does not expand or otherwise alter TI's applicable warranties or warranty disclaimers for TI products.

TI objects to and rejects any additional or different terms you may have proposed.

Mailing Address: Texas Instruments, Post Office Box 655303, Dallas, Texas 75265
Copyright © 2024, Texas Instruments Incorporated

Looking for pricing, stock, or lifecycle information?

Click below to explore more details on WIN SOURCE:

 [View REF3033AIDBZR on WIN SOURCE](#)

 [Texas Instruments](#) Information

Optimize Your Supply Chain with WIN SOURCE Solutions

-  Global Sourcing Solution
-  Obsolete Management
-  Cost Control Management
-  Shortage Management
-  Alternative Solution
-  Excess Inventory Management