



**THE DATASHEET OF  
RCLAMP3655P.TCT**



**PROTECTION PRODUCTS - RailClamp®**
**Description**

RailClamp® is a low capacitance TVS array designed to protect high speed data interfaces. This series has been specifically designed to protect sensitive components which are connected to data and transmission lines from overvoltage caused by **ESD** (electrostatic discharge), **CDE** (Cable Discharge Events), and **EFT** (electrical fast transients).

The RClamp3655P is specifically designed to protect portable devices that utilize a uUSB port with an additional FM radio pin. The unique design of this device features low capacitance TVS diodes for protection of the USB data (DP, DM), USB ID, and FM radio pins operating up to 5 volts. Loading capacitance on these lines is <1pF for maximum signal integrity. An integrated 28 volt TVS diode is used for protection of the USB voltage bus. This ensures the device will remain in a high-impedance state during normal USB operation or when the battery is being charged. Leakage current of the VBus protection is <250nA when operating at 28 volts.

The RClamp3655P is in an 8-pin, RoHS compliant, SLP3313P6 package. It measures 3.3 x 1.3 x 0.50mm. The leads are spaced at a pitch of 0.5mm and are finished with lead-free NiPdAu. They may be used to meet the ESD immunity requirements of IEC 61000-4-2, Level 4 (15kV air, 8kV contact discharge).

**Features**

- ◆ Transient protection for high-speed data lines to **IEC 61000-4-2 (ESD) ±15kV (air), ±8kV (contact) IEC 61000-4-4 (EFT) 40A (5/50ns)**
- ◆ Array of surge rated diodes with internal TVS Diode
- ◆ Small package saves board space
- ◆ Protects USB DP, DM, FM radio, and ID Pins to 5V
- ◆ Protects USB VBus operating up to 28V
- ◆ Low capacitance (**<1pF**) on DP, DM, FM and ID Pins
- ◆ No insertion loss to **2.0GHz**
- ◆ Low leakage current
- ◆ Low clamping voltage
- ◆ Innovative package for easy pcb layout
- ◆ Solid-state silicon-avalanche technology

**Mechanical Characteristics**

- ◆ SLP3313P6 8L package
- ◆ RoHS/WEEE Compliant
- ◆ Nominal Dimensions: 3.3 x 1.3 x 0.50 mm
- ◆ Lead Finish: NiPdAu
- ◆ Molding compound flammability rating: UL 94V-0
- ◆ Marking: Marking code
- ◆ Packaging: Tape and Reel

**Applications**

- ◆ uUSB Interfaces with FM radio Option
- ◆ USB OTG

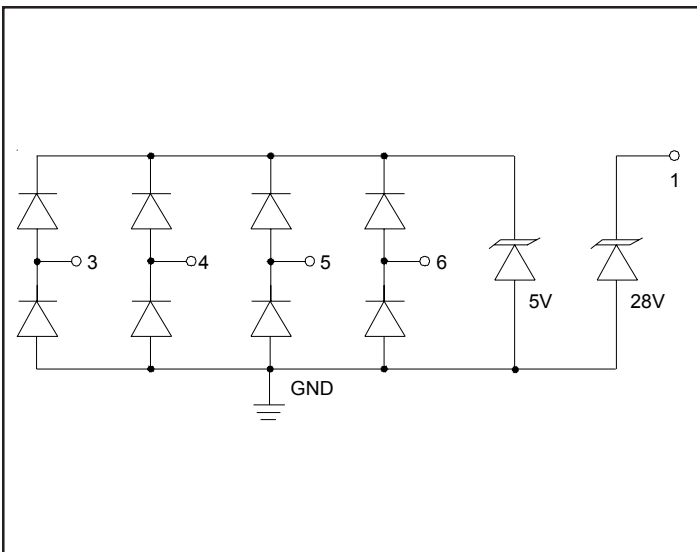
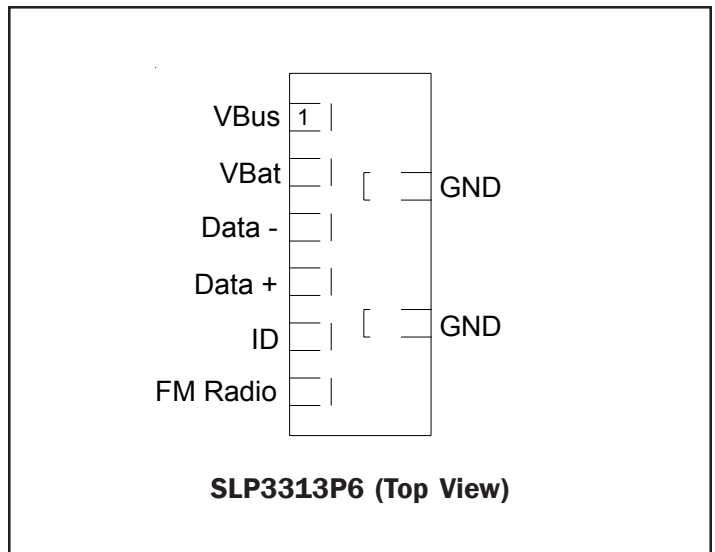
**Circuit Diagram**

**PIN Configuration**

**PROTECTION PRODUCTS**
**Absolute Maximum Rating**

| Rating   | Symbol    | Value       | Units |
|--|-----------|-------------|-------|
| <b>DP, DM, USB ID, FM Radio (Pins 3, 4, 5, 6)</b>              |           |             |       |
| Peak Pulse Power (tp = 8/20μs)                                 | $P_{pk}$  | 75          | Watts |
| Peak Pulse Current (tp = 8/20μs)                               | $I_{PP}$  | 5           | A     |
| ESD per IEC 61000-4-2 (Air)<br>ESD per IEC 61000-4-2 (Contact) | $V_{ESD}$ | ±18<br>±12  | kV    |
| Operating Temperature  | $T_J$     | -55 to +125 | °C    |
| Storage Temperature  | $T_{STG}$ | -55 to +150 | °C    |
| <b>VBus (Pin 1)</b>  |           |             |       |
| Peak Pulse Power (tp = 8/20μs)                                 | $P_{pk}$  | 350         | Watts |
| Peak Pulse Current (tp = 8/20μs)                               | $I_{PP}$  | 4           | A     |
| ESD per IEC 61000-4-2 (Air)<br>ESD per IEC 61000-4-2 (Contact) | $V_{ESD}$ | ±18<br>±12  | kV    |
| Operating Temperature  | $T_J$     | -55 to +125 | °C    |
| Storage Temperature  | $T_{STG}$ | -55 to +150 | °C    |

**PROTECTION PRODUCTS**
**Electrical Characteristics (T = 25°C)**

| DM, DP, USB ID, FM Radio (Pins 3, 4, 5, 6) |           |   |         |         |         |         |
|--|-----------|---|---------|---------|---------|---------|
| Parameter                                  | Symbol    | Conditions  | Minimum | Typical | Maximum | Units   |
| Reverse Stand-Off Voltage                  | $V_{RWM}$ | Pin 3, 4, 5, or 6 to GND                                      |         |         | 5       | V       |
| Reverse Breakdown Voltage                  | $V_{BR}$  | $I_t = 1mA$ ,<br>Pin 3, 4, 5, or 6 to GND                     | 6.5     | 8       | 11      | V       |
| Reverse Leakage Current                    | $I_R$     | $V_{RWM} = 5.0V$ ,<br>Pin 3, 4, 5, or 6 to GND                |         | 0.005   | 0.100   | $\mu A$ |
| Forward Voltage                            | $V_F$     | $I_f = 15mA$<br>GND to Pin 3, 4, 5, or 6                      | 0.6     |         | 1.2     | V       |
| Clamping Voltage                           | $V_C$     | $I_{pp} = 1A$ , $t_p = 8/20\mu s$<br>Pin 3, 4, 5, or 6 to GND |         |         | 12      | V       |
| Clamping Voltage                           | $V_C$     | $I_{pp} = 5A$ , $t_p = 8/20\mu s$<br>Pin 3, 4, 5, or 6 to GND |         |         | 15      | V       |
| Junction Capacitance                       | $C_j$     | $V_R = 0V$ , $f = 1MHz$ ,<br>Pin 3, 4, 5, or 6 to GND         |         | 0.7     | 0.80    | pF      |
|  |           | $V_R = 0V$ , $f = 1MHz$ ,<br>Between I/O pins                 |         |         | 0.4     | pF      |

**PROTECTION PRODUCTS**
**Electrical Characteristics (T = 25°C)**

| <b>VBus TVS (Pin 1)</b>   |               |  |                |                |                |               |
|---------------------------|---------------|--|----------------|----------------|----------------|---------------|
| <b>Parameter</b>          | <b>Symbol</b> | <b>Conditions</b>  | <b>Minimum</b> | <b>Typical</b> | <b>Maximum</b> | <b>Units</b>  |
| Reverse Stand-Off Voltage | $V_{RWM}$     | Pin 1 to GND   |                |                | 28             | V             |
| Reverse Breakdown Voltage | $V_{BR}$      | $I_t = 1\text{mA}$ ,<br>Pin 1 to GND                               | 32             | 36             | 40             | V             |
| Reverse Leakage Current   | $I_R$         | $V_{RWM} = 28\text{V}$<br>Pin 1 to GND                             |                | 0.010          | 0.250          | $\mu\text{A}$ |
| Forward Voltage           | $V_F$         | $I_f = 10\text{mA}$<br>GND to Pin 1                                | 0.6            |                | 1.0            | V             |
| Forward Clamping Voltage  | $V_{FC}$      | $I_{PP} = 10\text{A}$ , $t_p = 8/20\mu\text{s}$<br>Ground to Pin 1 |                |                | 3              | V             |
| Clamping Voltage          | $V_C$         | $I_{PP} = 1\text{A}$ , $t_p = 8/20\mu\text{s}$<br>Pin 1 to Ground  |                |                | 48             | V             |
| Junction Capacitance      | $C_J$         | $V_R = 0\text{V}$ , $f = 1\text{MHz}$<br>Pin 1 to GND              |                | 28             | 40             | pF            |

## PROTECTION PRODUCTS

### Typical Characteristics

**Non-Repetitive Peak Pulse Power vs. Pulse Time**  
(Data Lines - Pins 3, 4, 5, or 6 to GND)

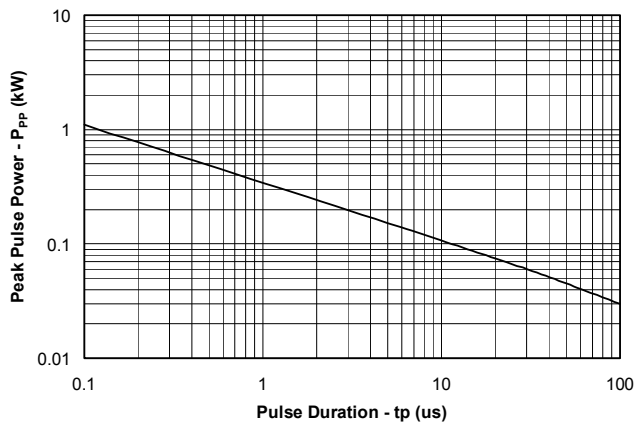

**Pulse Waveform**

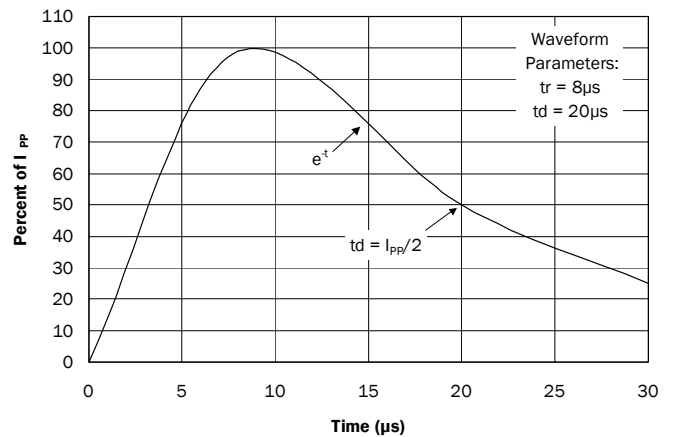

**Clamping Voltage vs. Peak Pulse Current**  
(Data Lines - Pins 3, 4, 5, or 6 to GND)

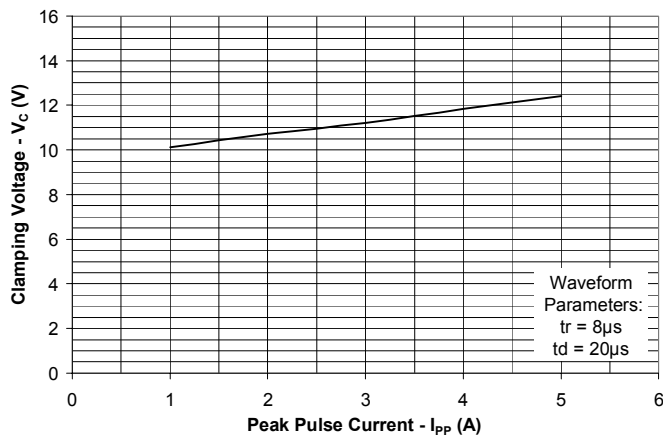

**Clamping Voltage vs. Peak Pulse Current**  
(VBus - Pin 1 to GND)

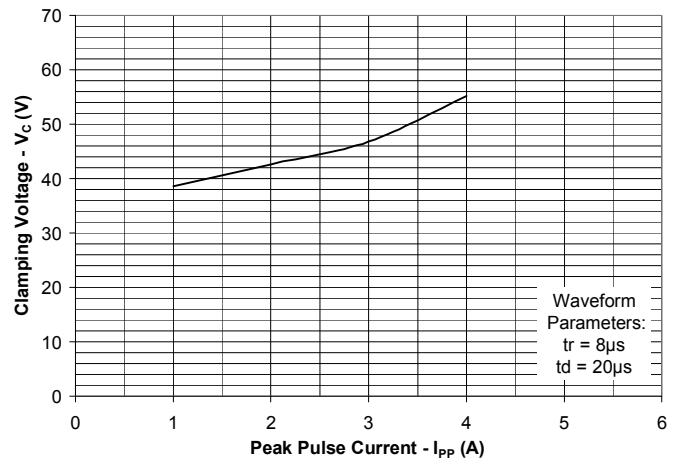

**Normalized Capacitance vs. Reverse Voltage**  
(Data Lines - Pin 3, 4, 5, or 6 to GND)

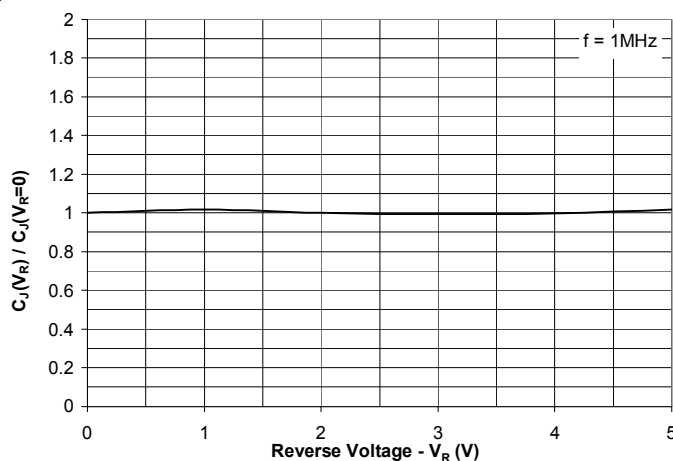

**USB 2.0 Eye Pattern with RClamp3655P**  
(Data Lines - Pin 3 and 4)

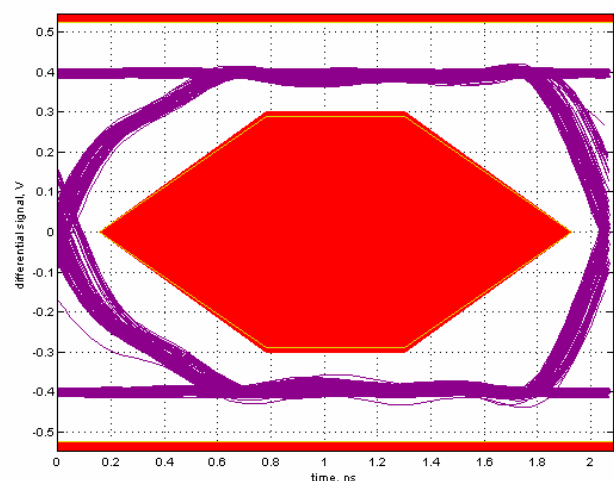

## PROTECTION PRODUCTS

### Typical Characteristics

**Insertion Loss S21  
(Pin 3, 4, 5, or 6 to GND)**

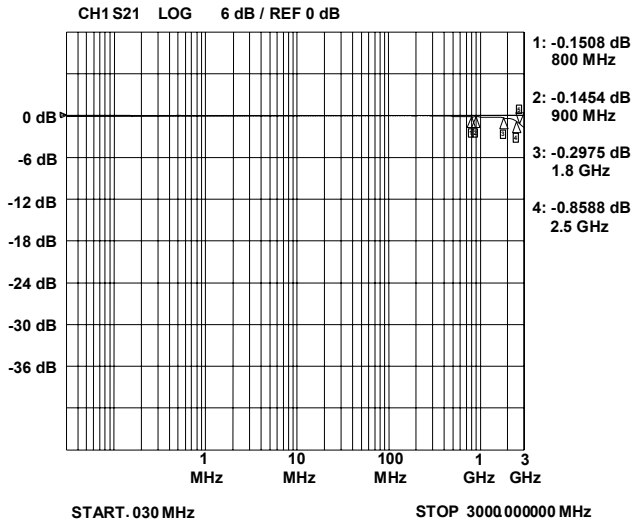

**Analog Crosstalk**

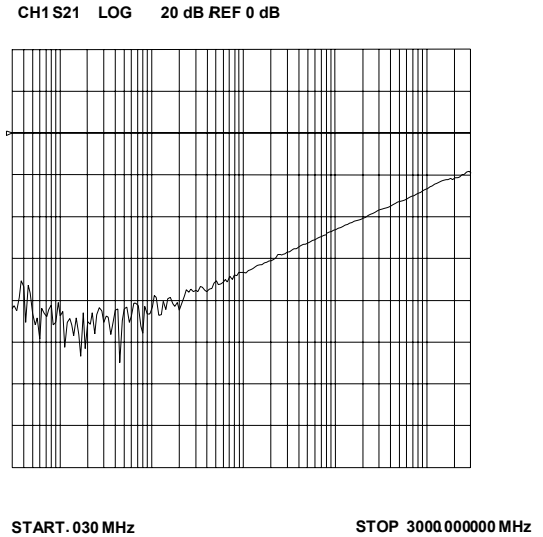

**ESD Clamping (Pin 3, 4, 5, or 6 to GND)  
(+8kV Contact per IEC 61000-4-2)**

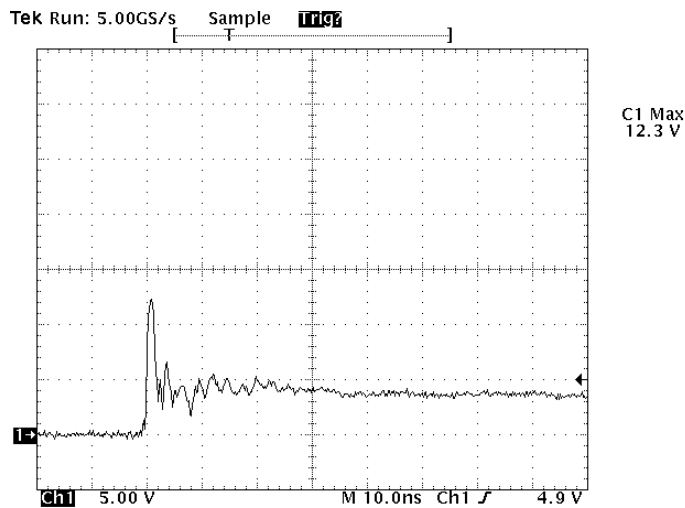

Note: Data is taken with a 10x attenuator

**ESD Clamping (Pin 1 to GND)  
(+8kV Contact per IEC 61000-4-2)**

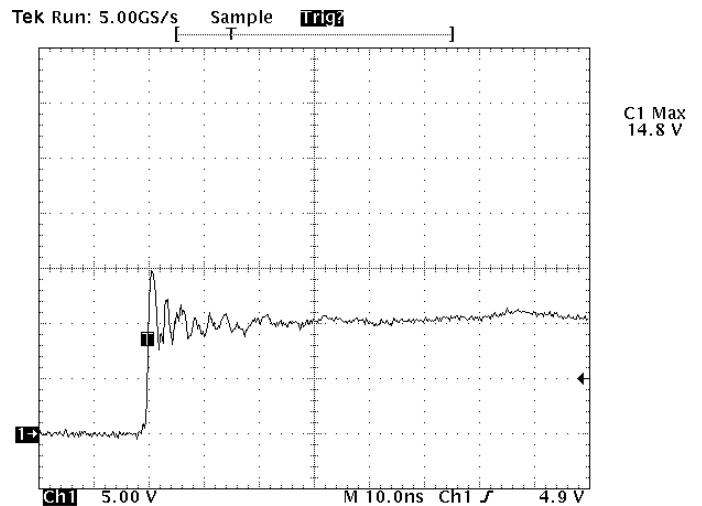

Note: Data is taken with a 10x attenuator

## PROTECTION PRODUCTS

### Applications Information

#### Device Connection and Layout Options for Protecting One USB Port

The RClamp3655P is optimized for use on systems that utilize the uUSB interface with an additional FM radio pin. Low capacitance protection is provided for the USB data (DM, DP), USB ID, and FM radio pins. The maximum capacitance on these lines is <math><1\text{pF}</math> for maximum signal integrity. USB Data, FM radio, and ID lines are connected at pins 3, 4, 5, and 6. These inputs are referenced to an internal 5 volt TVS protection device. When the voltage on these lines exceed 5 volts, the TVS will conduct. Pin 1 is connected to the USB voltage bus (VBus). This device will conduct when the voltage on the bus exceeds 28 volts. Note that there is no internal connection to the VBat pin. Multiple micro vias connected to ground are recommended for best ESD performance. This will reduce parasitic inductance in the ground path and minimize the clamping voltage seen by the protected device. The package is designed for easy trace routing as shown in the Figure 2 examples. The top example is preferred as it utilizes an extended ground connection using multiple micro vias. Note that it is not necessary to connect both ground pins of the device as both are connected internally. In this example, the VBat pin is routed on a separate layer. The VBus pin is connected to the voltage layer of the PCB with a micro via. If connection to the VBat pin is required, the bottom layout can be used. This example utilizes one via to ground due to space constraints.

Figure 1- Pin Configuration

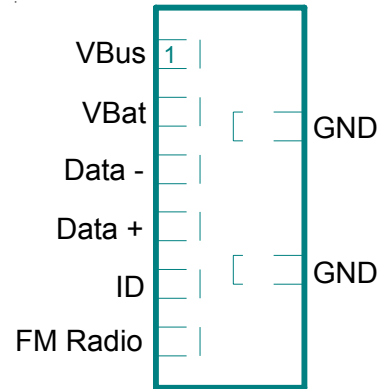
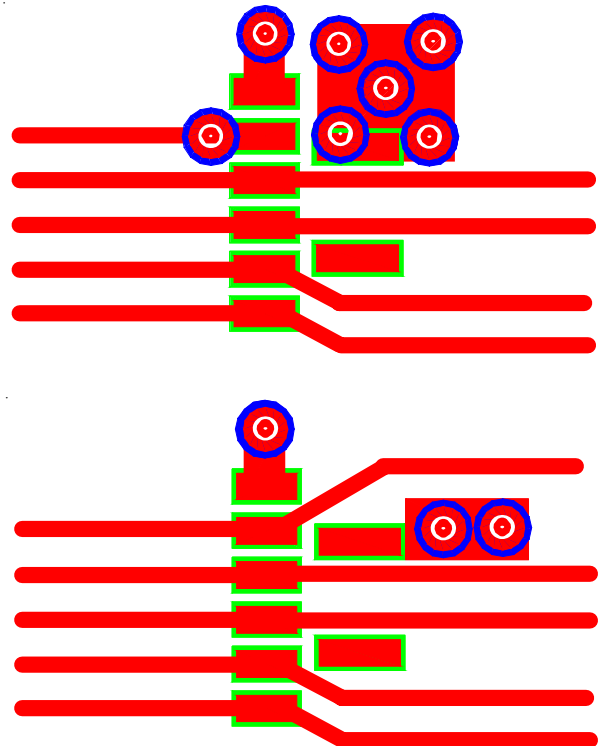
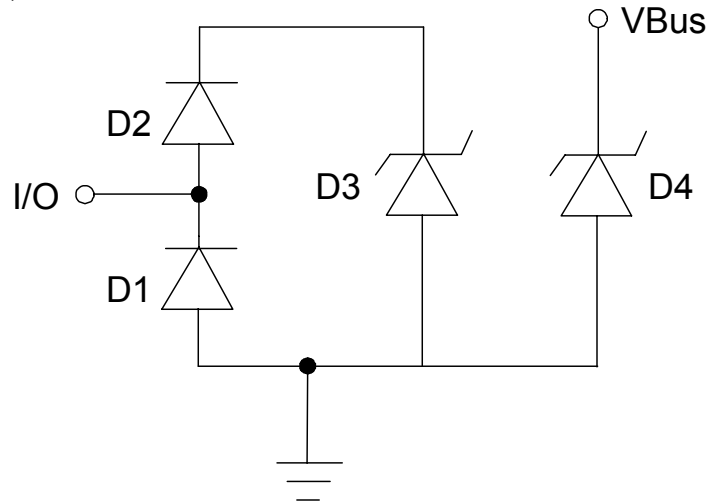

Figure 2 - Layout Examples





**RClamp3655P Spice Model**

| RClamp3655P Spice Parameters |       |          |          |          |          |
|------------------------------|-------|----------|----------|----------|----------|
| Parameter                    | Unit  | D1       | D2       | D3       | D4       |
| IS                           | Amp   | 1E-20    | 1E-20    | 2E-12    | 2.93E-12 |
| BV                           | Volt  | 100      | 100      | 8.2      | 35       |
| VJ                           | Volt  | 0.83     | 0.83     | 0.6      | 0.64     |
| RS                           | Ohm   | 1.5      | 0.6      | 0.2      | 4.13     |
| IBV                          | Amp   | 1E-3     | 1E-3     | 1E-3     | 1E-3     |
| CJO                          | Farad | 0.25E-12 | 0.25E-12 | 56E-12   | 25E-12   |
| TT                           | sec   | 2.541E-9 | 2.541E-9 | 2.541E-9 | 2.541E-9 |
| M                            | --    | 0.01     | 0.01     | 0.23     | 0.32     |
| N                            | --    | 1.1      | 1.1      | 1.1      | 1.1      |
| EG                           | eV    | 1.11     | 1.11     | 1.11     | 1.11     |

PROTECTION PRODUCTS

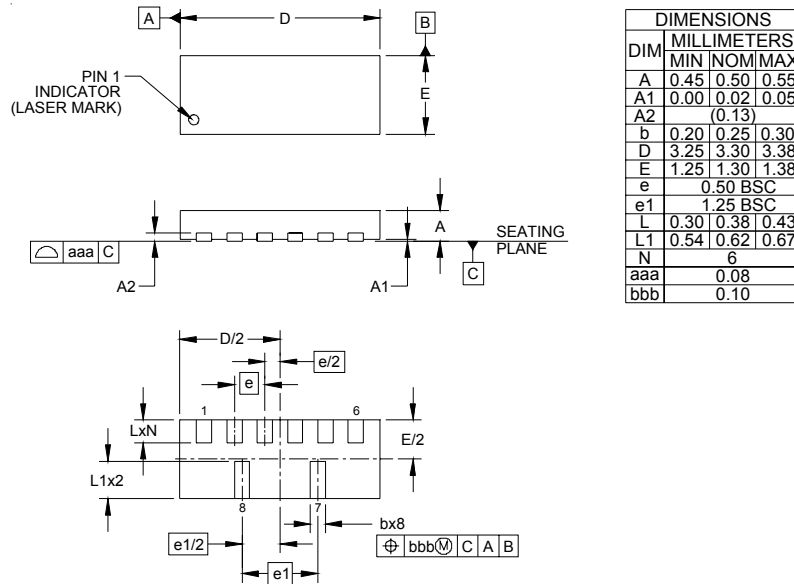
Outline Drawing - SLP3313P6



- NOTES:
1. CONTROLLING DIMENSIONS ARE IN MILLIMETERS (ANGLES IN DEGREES).
  2. COPLANARITY APPLIES TO THE EXPOSED PAD AS WELL AS THE TERMINALS.

Land Pattern - SLP3313P6

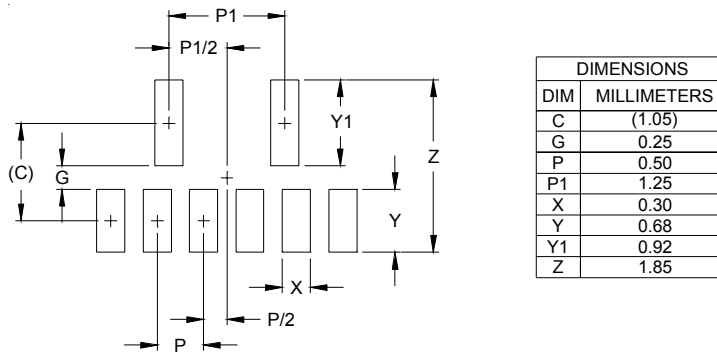

- NOTES:
1. CONTROLLING DIMENSIONS ARE IN MILLIMETERS (ANGLES IN DEGREES).
  2. THIS LAND PATTERN IS FOR REFERENCE PURPOSES ONLY. CONSULT YOUR MANUFACTURING GROUP TO ENSURE YOUR COMPANY'S MANUFACTURING GUIDELINES ARE MET.

## PROTECTION PRODUCTS

### Marking

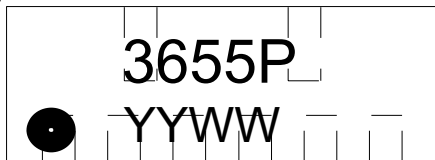

### Ordering Information

| Part Number     | Lead Finish | Qty per Reel | Reel Size |
|-----------------|-------------|--------------|-----------|
| RClamp3655P.TCT | Pb Free     | 3,000        | 7 Inch    |

RailClamp and RClamp are marks of Semtech Corporation

YYWW = Date Code

### Tape and Reel Specification

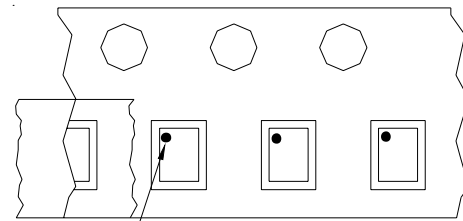
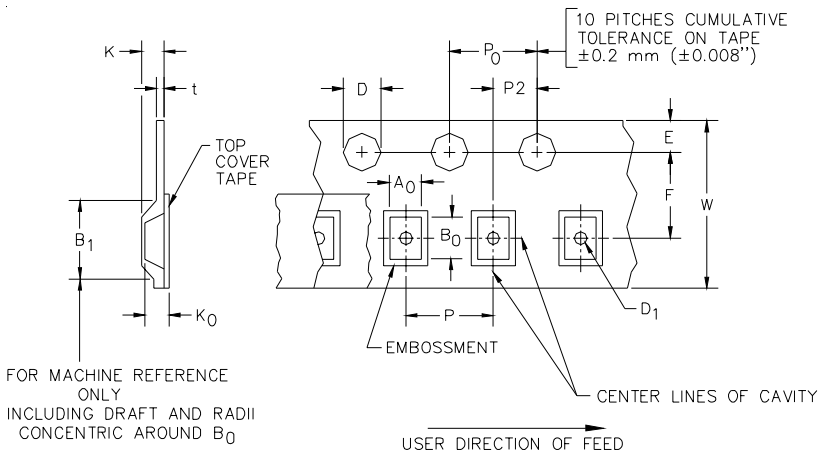

Pin 1 Location

→ User Direction of feed

**Device Orientation in Tape**  
**Pin 1 in upper left towards sprocket holes**

| A0              | B0              | K0              |
|-----------------|-----------------|-----------------|
| 1.51 +/-0.10 mm | 3.51 +/-0.10 mm | 0.66 +/-0.10 mm |

| Tape Width | B, (Max) | D                          | D1              | E               | F              | K (MAX) | P             | P0            | P2             | T(MAX) | W                              |
|------------|----------|----------------------------|-----------------|-----------------|----------------|---------|---------------|---------------|----------------|--------|--------------------------------|
| 8 mm       | 4.2 mm   | 1.5 + 0.1 mm<br>- 0.0 mm ) | 0.5 mm<br>±0.05 | 1.750±.10<br>mm | 3.5±0.05<br>mm | 2.4 mm  | 4.0±0.1<br>mm | 4.0±0.1<br>mm | 2.0±0.05<br>mm | 0.4 mm | 8.0 mm<br>+ 0.3 mm<br>- 0.1 mm |

### Contact Information

Semtech Corporation  
 Protection Products Division  
 200 Flynn Rd., Camarillo, CA 93012  
 Phone: (805)498-2111 FAX (805)498-3804

## Looking for pricing, stock, or lifecycle information?

Click below to explore more details on WIN SOURCE:

- ⊖ [View RCLAMP3655P.TCT on WIN SOURCE](#)
- ⊖ [Semtech Corporation](#) Information

## Optimize Your Supply Chain with WIN SOURCE Solutions

- ✓ Global Sourcing Solution
- ✓ Obsolete Management
- ✓ Cost Control Management
- ✓ Shortage Management
- ✓ Alternative Solution
- ✓ Excess Inventory Management