



**THE DATASHEET OF
RC28F128K3C**





Intel StrataFlash[®] Synchronous Memory (K3/K18)

28F640K3, 28F640K18, 28F128K3, 28F128K18, 28F256K3,
28F256K18 (x16)

Datasheet

Product Features

- **Performance**
 - 110/115/120 ns Initial Access Speed for 64/128/256 Mbit Densities
 - 25 ns Asynchronous Page-Mode Reads, 8 Words Wide
 - 13 ns Synchronous Burst-Mode Reads, 8 or 16 Words Wide
 - 32-Word Write Buffer
 - Buffered Enhanced Factory Programming
- **Software**
 - 25 μ s (typ.) Program and Erase Suspend Latency Time
 - Flash Data Integrator (FDI), Common Flash Interface (CFI) Compatible
 - Programmable WAIT Signal Polarity
- **Quality and Reliability**
 - Operating Temperature: -40 °C to +85 °C
 - 100K Minimum Erase Cycles per Block
 - 0.18 μ m ETOX[™] VII Process
- **Architecture**
 - Multi-Level Cell Technology: High Density at Low Cost
 - Symmetrical 64 K-Word Blocks
 - 256 Mbit (256 Blocks)
 - 128 Mbit (128 Blocks)
 - 64 Mbit (64 Blocks)
 - Ideal for “CODE + DATA” applications
- **Security**
 - 2-Kbit Protection Register
 - Unique 64-bit Device Identifier
 - Absolute Data Protection with V_{PEN} and WP#
 - Individual and Instantaneous Block Locking, Unlocking and Lock-Down Capability
- **Packaging and Voltage**
 - 64-Ball Intel[®] Easy BGA Package (128-Mbit is also offered in a lead-free package)
 - 56-and 79-Ball Intel[®] VF BGA Package
 - V_{CC} = 2.70 V to 3.60 V
 - V_{CCQ} = 1.65 to 1.95 V/2.375 to 3.60 V

The Intel StrataFlash[®] Synchronous Memory (K3/K18) product line adds a high performance burst-mode interface and other additional features to the Intel StrataFlash[®] memory family of products. Just like its J3 counterpart, the K3/K18 device utilizes reliable and proven two-bit-per-cell technology to deliver 2x the memory in 1x the space, offering high density flash at low cost. This is Intel's third generation MLC technology, manufactured on 0.18 μ m lithography, making it the most widely used and proven MLC product family on the market.

K3/K18 is a 3-volt device (core), but it is available with 3-volt (K3) or 1.8-volt (K18) I/O voltages. These devices are ideal for mainstream applications requiring large storage space for both code and data storage. Advanced system designs will benefit from the high performance page and burst modes for direct execution from the flash memory. Available in densities from 64 Mbit to 256 Mbit (32 Mbyte), the K3/K18 device is the highest density NOR-based flash component available today, just as it was when Intel introduced the original device in 1997.

Notice: This document contains information on new products in production. The specifications are subject to change without notice. Verify with your local Intel sales office that you have the latest datasheet before finalizing a design.



Information in this document is provided in connection with Intel® products. No license, express or implied, by estoppel or otherwise, to any intellectual property rights is granted by this document. Except as provided in Intel's Terms and Conditions of Sale for such products, Intel assumes no liability whatsoever, and Intel disclaims any express or implied warranty, relating to sale and/or use of Intel products including liability or warranties relating to fitness for a particular purpose, merchantability, or infringement of any patent, copyright or other intellectual property right. Intel products are not intended for use in medical, life saving, or life sustaining applications.

Intel may make changes to specifications and product descriptions at any time, without notice.

Designers must not rely on the absence or characteristics of any features or instructions marked "reserved" or "undefined." Intel reserves these for future definition and shall have no responsibility whatsoever for conflicts or incompatibilities arising from future changes to them.

The 3 Volt Synchronous Intel StrataFlash® Memory may contain design defects or errors known as errata which may cause the product to deviate from published specifications. Current characterized errata are available on request.

Contact your local Intel sales office or your distributor to obtain the latest specifications and before placing your product order.

Copies of documents which have an ordering number and are referenced in this document, or other Intel literature may be obtained by calling 1-800-548-4725 or by visiting Intel's website at <http://www.intel.com>.

Copyright © Intel Corporation, 2005.

*Other names and brands may be claimed as the property of others.

Contents

1.0	Introduction	7
	1.1 Nomenclature	7
	1.2 Conventions	8
2.0	Functional Overview	9
	2.1 High Performance Page/Burst Modes	9
	2.2 Single Chip Solution	9
	2.3 Packaging Options	10
	2.4 Product Highlights	10
	2.5 K3/K18 Block Diagram	11
	2.6 Memory Map	12
3.0	Package Information	13
	3.1 Easy BGA Package	13
	3.2 VF BGA for 64 Mbit and 128 Mbit Package	14
	3.3 VF BGA for 256 Mbit Package	15
4.0	Ballout and Signal Description	17
	4.1 64-Ball Easy BGA Package for All Densities (1.0 mm Ball Pitch)	17
	4.2 56-Ball VF BGA Package for 64- and 128-Mbit Density (0.75 mm Ball Pitch)	18
	4.3 79-Ball VF BGA for 256-Mbit Density Package	19
	4.4 Signal Descriptions	20
5.0	Maximum Ratings and Operating Conditions	21
	5.1 Absolute Maximum Ratings	21
	5.2 Operating Conditions	21
6.0	Electrical Specifications	22
	6.1 DC Current Characteristics	22
7.0	AC Characteristics	24
	7.1 Read Operations	24
	7.2 Write Operation	29
	7.3 Block Erase and Program Operation Performance	31
	7.4 AC Test Conditions	32
	7.5 Capacitance	32
8.0	Power and Reset	33
	8.1 Power-Up/Down Characteristics	33
	8.2 Power Supply Decoupling	33
	8.3 Reset Characteristics	33
	8.4 Reset Operation	34
9.0	Bus Operations	35
	9.1 Bus Operations Overview	35
	9.1.1 Read Mode	35
	9.1.2 Write/Program	36

	9.1.3	Output Disable	36
	9.1.4	Standby	36
	9.1.5	Reset	36
	9.2	Device Commands	37
10.0		Read Modes	39
	10.1	Asynchronous Page-Mode Read	39
	10.2	Synchronous Burst-Mode Read	40
	10.3	Read Configuration Register	40
	10.3.1	Read Mode	41
	10.3.2	Latency Count	41
	10.3.3	WAIT Polarity	43
	10.3.4	Data Hold	43
	10.3.5	WAIT Delay	44
	10.3.6	Burst Sequence	44
	10.3.7	Clock Edge	44
	10.3.8	Burst Length	44
11.0		Program Modes	45
	11.1	Word Programming	45
	11.2	Write-Buffer Programming	45
	11.3	Program Suspend	46
	11.4	Program Resume	47
	11.5	Buffered Enhanced Factory Programming (Buffered-EFP)	47
	11.5.1	Buffered-EFP Requirements and Considerations	47
	11.5.2	Buffered-EFP Setup Phase	48
	11.5.3	Buffered-EFP Program and Verify Phase	48
	11.5.4	Buffered-EFP Exit Phase	49
12.0		Erase Mode	50
	12.1	Block Erase	50
	12.2	Erase Suspend	50
	12.3	Erase Resume	51
13.0		Security Modes	52
	13.1	Block Locking Operations	52
	13.1.1	Block Lock	53
	13.1.2	Block Unlock	53
	13.1.3	Block Lock-Down	53
	13.1.4	Block Lock During Erase Suspend	53
	13.1.5	WP# Lock-Down Control	53
	13.2	Protection Registers	54
	13.2.1	Reading the Protection Registers	55
	13.2.2	Programming the Protection Registers	55
	13.2.3	Locking the Protection Registers	55
	13.3	Array Protection	55
14.0		Special Modes	56
	14.1	Read Status Register	56
	14.1.1	Clear Status Register	57
	14.2	Read Device Identifier	57



14.3	Read Query/CFI	58
14.4	STS Configuration (Easy BGA package ONLY).....	58
Appendix A	Write State Machine (WSM).....	59
Appendix B	Common Flash Interface	64
Appendix C	Flowcharts.....	70
Appendix D	Additional Information	78
Appendix E	Ordering Information	79

Revision History

Date of Revision	Revision	Description
08/22/01	-001	Original Version
09/24/01	-002	Corrected Typographical Errors in 11.0 AC Characteristics section.
09/27/01	-003	Change VFBGA Package from 64 to 56 ball package. Add ordering info in Appendix E.
02/22/02	-004	Changes to ballouts per engineering review and editing/formatting updates.
06/17/02	-005	Changes to Iccr, elimination of Speed Bin 2, expansion of Vccq range.
06/11/03	-006	Corrections to Ordering Information, typos, added Next-State Table, Appendix A info. Added table of Latency Count settings to Section 4.3.2.
12/01/03	-007	Update PDF presentation.
5/19/04	-008	Reformatted the document layout.
2/1/05	-009	Added lead-free information.

1.0 Introduction

This document contains information pertaining to the Intel StrataFlash® Synchronous Memory (K3/K18) device. The purpose of this document is to describe the features, operations and specifications of these devices.

1.1 Nomenclature

3 Volt core:	V_{CC} range of 2.7 V – 3.6 V
3 Volt I/O:	V_{CCQ} range of 2.375 V – 3.6 V
1.8 Volt I/O:	V_{CCQ} range of 1.65 V – 1.95 V
A_{MIN}:	For Easy BGA packages: $A_{MIN} = A1$ For VF BGA packages: $A_{MIN} = A0$
A_{MAX}:	For Easy BGA packages: 64 Mbit $A_{MAX} = A22$ 128 Mbit $A_{MAX} = A23$ 256 Mbit $A_{MAX} = A24$ For VF BGA packages: 64 Mbit $A_{MAX} = A21$ 128 Mbit $A_{MAX} = A22$ 256 Mbit $A_{MAX} = A23$
Block:	A group of flash cells that share common erase circuitry and erase simultaneously
Program:	To write data to the flash array
VPEN:	Refers to a signal or package connection name
V_{PEN}:	Refers to timing or voltage levels
CUI:	Command User Interface
OTP:	One Time Programmable
PR:	Protection Register
PLR:	Protection Lock Register
RFU:	Reserved for Future Use
SR:	Status Register
RCR:	Read Configuration Register
WSM:	Write State Machine
MLC:	Multi-Level Cell
Set:	Indicates a logic one (1)
Clear:	Indicates a logic zero (0)

1.2 Conventions

0x:	Hexadecimal prefix
0b:	Binary prefix
k (noun):	1,000
M (noun):	1,000,000
Byte:	8 bits
Word:	16 bits
Kword:	1,024 words
Kb:	1,024 bits
KB:	1,024 bytes
Mb:	1,048,576 bits
MB:	1,048,576 bytes
Brackets:	Square brackets ([]) will be used to designate group membership or to define a group of signals with similar function (i.e. A[21:1], SR[4,1] and D[15:0]).

2.0 Functional Overview

This section provides an overview of the K3/K18 device features and architecture.

The K3/K18 device product line adds a high performance burst-mode interface and other additional features to the Intel StrataFlash[®] memory family of products. Just like its J3 counterpart, the K3/K18 utilizes reliable and proven two-bit-per-cell technology to deliver 2x the memory in 1x the space, offering high density flash at low cost. This is the third generation of Intel's multi-level cell (MLC) technology, manufactured on 0.18 μm lithography, making it the most widely used and proven MLC product family on the market.

K3/K18 is a 3-volt device (core), but it is available with 3-volt (K3) or 1.8-volt (K18) I/O voltages. These devices are ideal for mainstream applications requiring large storage space for both code and data storage. Advanced system designs will benefit from the high performance page and burst modes for direct execution from the flash memory. Available in densities from 64 Mb to 256 Mbit (32 Mbyte), the K3/K18 device is the highest density NOR-based flash component available today, just as it was when Intel introduced the original device in 1997.

2.1 High Performance Page/Burst Modes

NOR-based flash is generally preferred over other architectures for its reliability and fast read speeds. Fast reads allow the application to execute code directly out of flash, rather than downloading to RAM for execution, saving the costs of redundant system memory and board space. The K3/K18 device sets the standard for fast read speeds by adding burst mode and utilizing an 8 word page mode. Burst mode increases throughput up to 76MB/s, effectively five times faster than asynchronous reads on standard flash memory, and supports performance up to 66 Mhz with zero wait states. Both page and burst modes also provide a high performance glueless interface to the Intel[®] StrongARM[®] SA-1110 CPU (and future Intel[®] XScale processors) and many other microprocessors.

2.2 Single Chip Solution

In addition to code execution, many applications also have data storage needs. K3/K18 memory provides a single-chip solution for combined code execution and data storage. A single-chip solution is easy to implement by utilizing a unique hardware and software combination: the K3/K18 device and Intel[®] Persistent Storage Manager (Intel[®] PSM). Intel[®] PSM is royalty free when used with Intel[®] Flash, is an installable file system and block device driver for Microsoft Windows[®] CE OS version 2.1 and later.

The Intel[®] PSM software is appropriate for any application using the Microsoft Windows CE operating system, including PC Companions, Set-Top Boxes, and other connected appliances and hand-held devices. Other operating system ports are also available. Intel[®] PSM is optimized for the Intel StrataFlash[®] Memory product line.

For wireless applications, Intel[®] Flash Data Integrator (Intel[®] FDI) Version 4 software provides the ability to manage data and files in Intel StrataFlash[®] Memory in an open architecture, including support for downloaded Java[®] applets, Bluetooth[®] file transfers, and voice recognition tags.

2.3 Packaging Options

The K3/K18 device is available in multiple packages: lead and lead-free Easy BGA and VF BGA, and Stacked Chip Scale Package (SCSP, stacking with SRAM or flash + flash). The 64-ball Easy BGA package provides SOP reliability and long-term footprint compatibility and cost in a chip scale package size. The VF BGA and SCSP offer small footprints for wireless applications.

Manufactured on the Intel 0.18-micron process technology, Intel StrataFlash® Memory offers unprecedented value and performance and reliability.

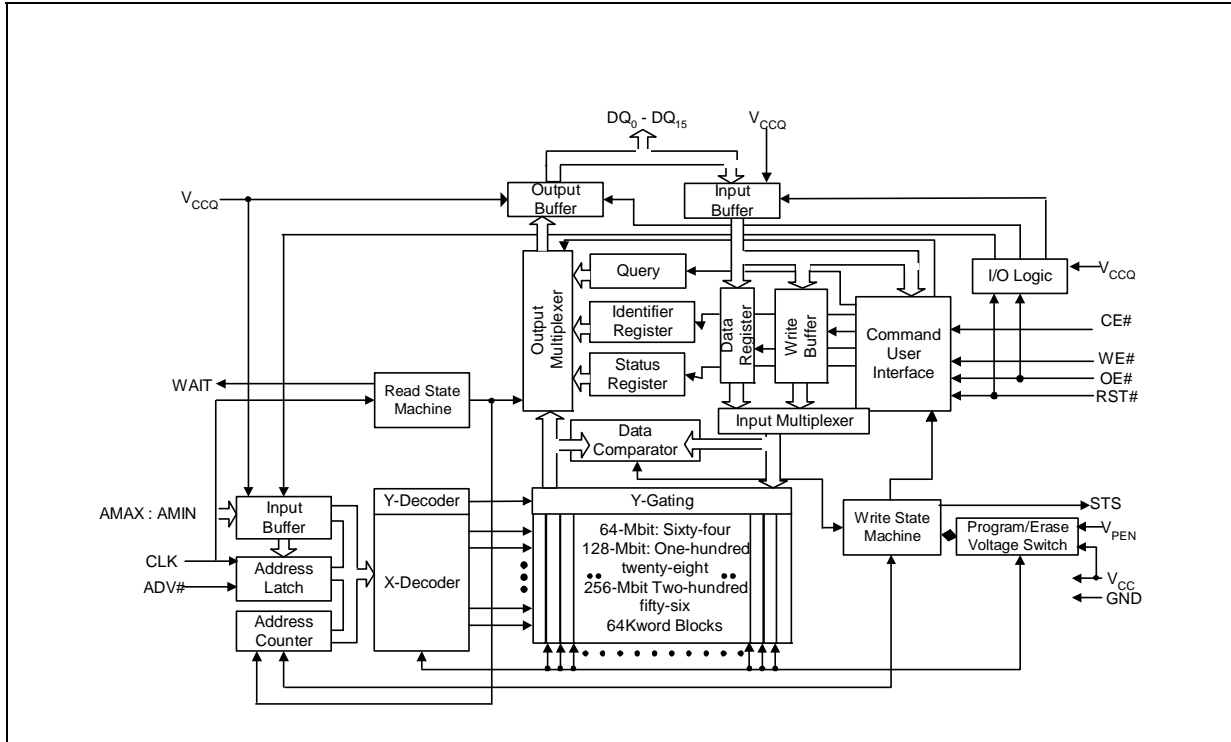
2.4 Product Highlights

High performance read modes: 8 or 16-word synchronous burst, 8-word page:

- 64 Mb: 110/25/13 ns (async/page/burst)
- 128 Mb: 115/25/13 ns (Offered in both lead and lead-free Easy BGA packages)
- 256 Mb: 120/25/13 ns
- 2.7 V to 3.6 V V_{CC} operation
- 64-ball Easy BGA
- VF BGA packages and Stacked Chip Scale Package (SCSP)
- I/O V_{CCQ}: 2.375 V to 3.6 V (K3); 1.65 V to 1.95 V (K18)
- One-time-programmable protection registers (2Kbits)
- Program and Erase suspend capability
- Cost-effective multi-level cell architecture
- Royalty-free software support for most applications with Intel® PSM, Intel® FDI Version 4, or VFM
- Full extended operating temperature: -40° C to +85° C
- Proven reliability: 100,000 cycles, up to 20 years data retention

2.5 K3/K18 Block Diagram

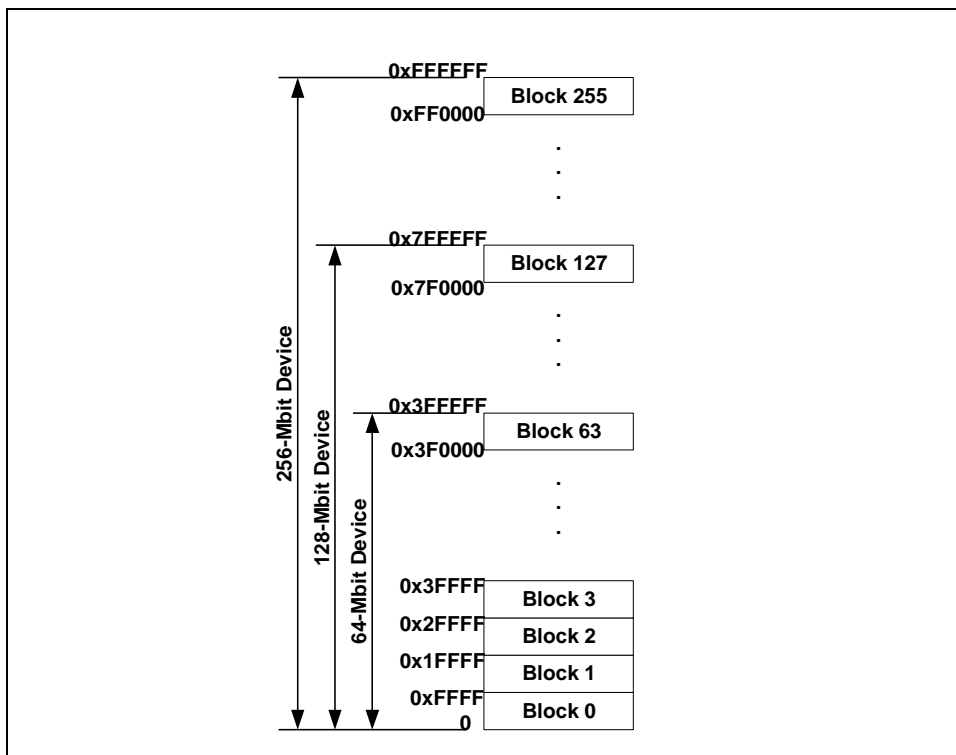
Figure 1. K3/K18 Device Memory Block Diagram



2.6 Memory Map

The K3/K18 device array is divided into symmetrical blocks that are 64-Kword in size. A 64 Mbit device contains 64 blocks, a 128 Mbit device contains 128 blocks and a 256 Mbit device contains 256 blocks. Flash cells within a block are organized by rows and columns. A block contains 512 rows by 128 words. The words on a row are divided into 16 eight-word groups. (See Figure 2.)

Figure 2. K3/K18 Device Memory Map



3.0 Package Information

3.1 Easy BGA Package

Figure 3. Easy BGA Package Drawing

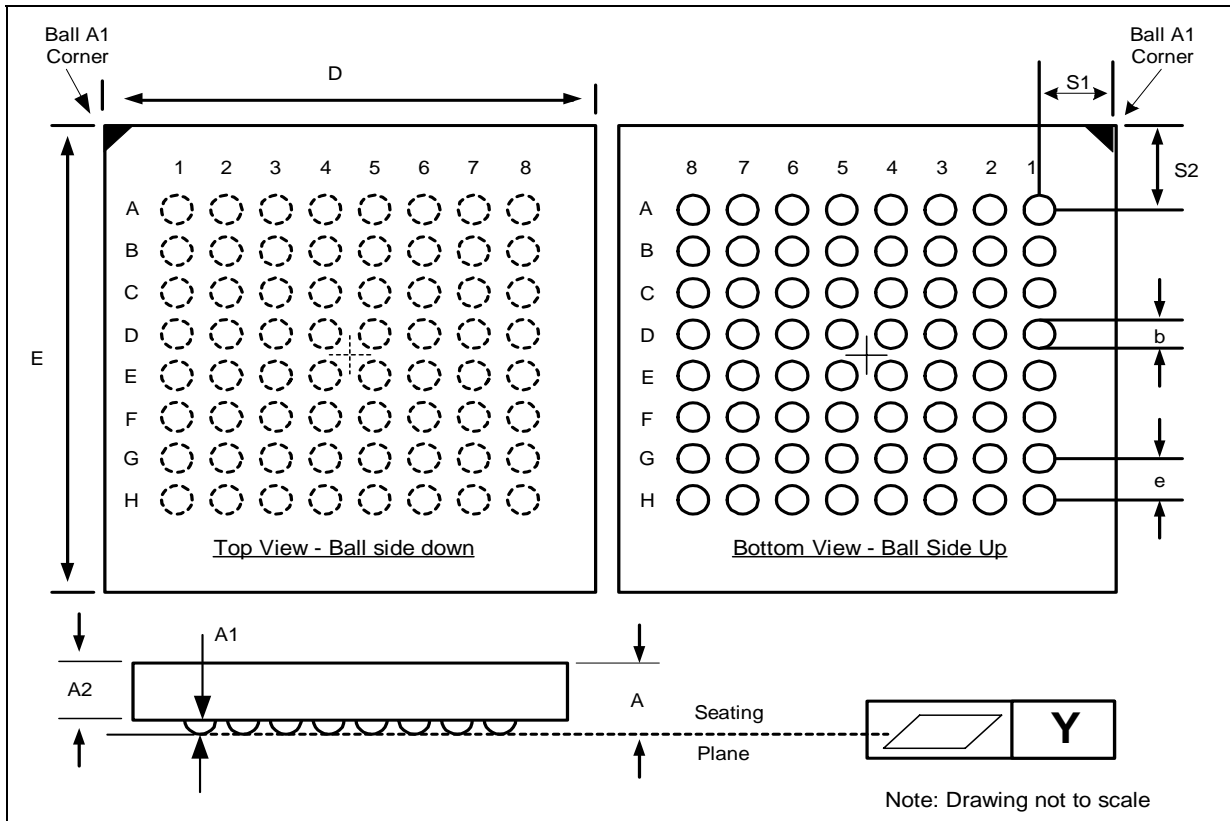


Table 1. Easy BGA Package Dimensions (Sheet 1 of 2)

	Symbol	Millimeters				Inches		
		Min	Nom	Max	Notes	Min	Nom	Max
Package Height	A			1.200				0.0472
Ball Height	A1	0.250				0.0098		
Package Body Thickness	A2		0.780				0.0307	
Ball Width	b	0.330	0.430	0.530		0.0130	0.0169	0.0209
Package Body Width (64 Mb, 128 Mb, 256 Mb)	D	9.900	10.000	10.100	1	0.3898	0.3937	0.3976
Package Body Length (64 Mb, 128 Mb)	E	12.900	13.000	13.100	1	0.5079	0.5118	0.5157
Package Body Length (256 Mb)	E	14.900	15.000	15.100	1	0.5866	0.5906	0.5945
Pitch	[e]		1.000				0.0394	
Ball Count	N		64				64	

Table 1. Easy BGA Package Dimensions (Sheet 2 of 2)

	Symbol	Millimeters				Inches		
		Min	Nom	Max	Notes	Min	Nom	Max
Seating Plane Coplanarity	Y			0.100				0.0039
Corner to Ball A1 Distance Along D (64/128/256 Mb)	S1	1.400	1.500	1.600	1	0.0551	0.0591	0.0630
Corner to Ball A1 Distance Along E (64/128 Mb)	S2	2.900	3.000	3.100	1	0.1142	0.1181	0.1220
Corner to Ball A1 Distance Along E (256 Mb)	S2	3.900	4.000	4.100	1	0.1535	0.1575	0.1614

3.2 VF BGA for 64 Mbit and 128 Mbit Package

Figure 4. VF BGA for 64 Mb and 128 Mb Package Drawing

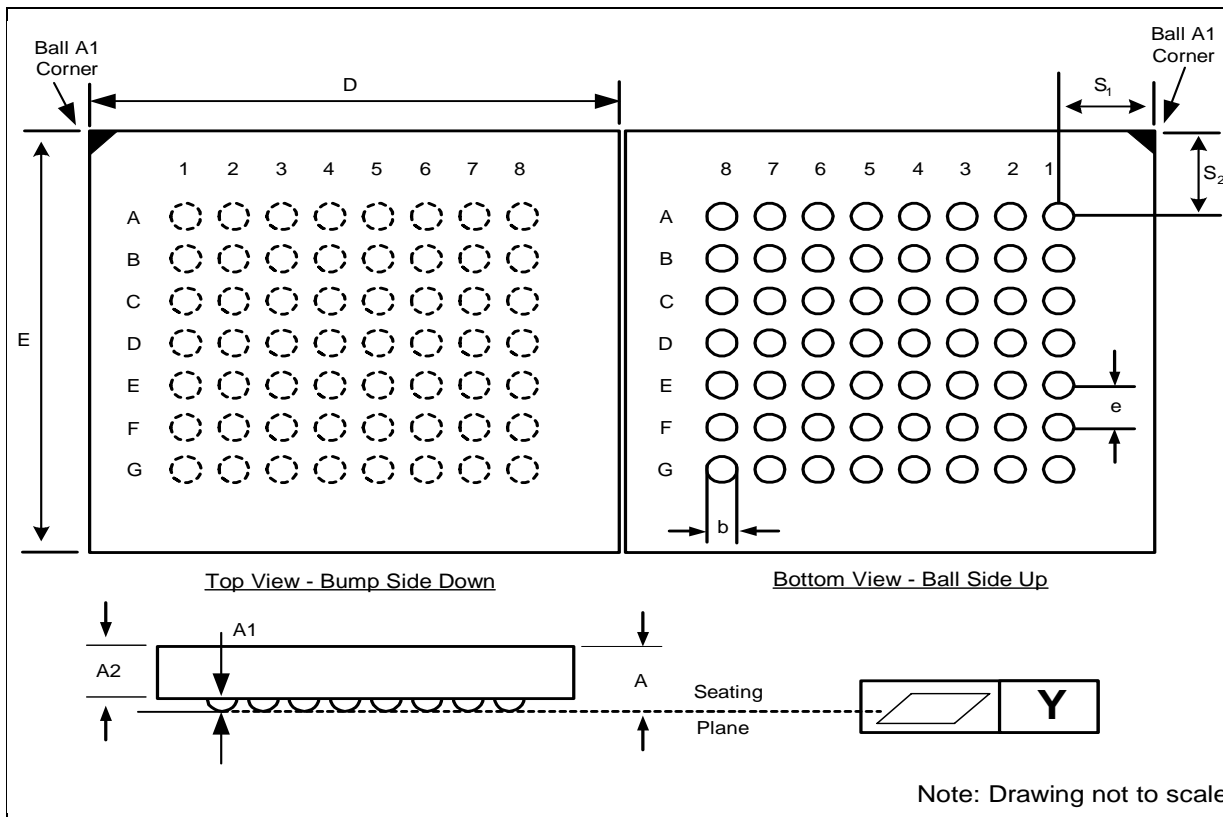


Table 2. VF BGA Package (64 Mb and 128 Mb) Dimensions (Sheet 1 of 2)

	Symbol	Millimeters				Inches		
		Min	Nom	Max	Notes	Min	Nom	Max
Package Height	A			1.000				0.0394
Ball Height	A1	0.150				0.0059		
Package Body Thickness	A2		0.665				0.0262	

Table 2. VF BGA Package (64 Mb and 128 Mb) Dimensions (Sheet 2 of 2)

	Symbol	Millimeters				Inches		
		Min	Nom	Max	Notes	Min	Nom	Max
Ball (Lead) Width	b	0.325	0.375	0.425		0.0128	0.0148	0.0167
Package Body Width (64 Mb)	D	7.600	7.700	7.800	1	0.2992	0.3031	0.3071
Package Body Width (128 Mb)	D	10.900	11.000	11.100	1	0.4291	0.4331	0.4370
Package Body Length (64 Mb, 128 Mb)	E	8.900	9.000	9.100	1	0.3504	0.3543	0.3583
Pitch	[e]		0.750				0.0295	
Ball (Lead) Count	N		56				56	
Seating Plane Coplanarity	Y			0.100				0.0039
Corner to Ball A1 Distance Along D (64 Mb)	S1	1.125	1.225	1.325	1	0.0443	0.0482	0.0522
Corner to Ball A1 Distance Along E (128 Mb)	S1	2.775	2.875	2.975	1	0.1093	0.1132	0.1171
Corner to Ball A1 Distance Along E (64 Mb, 128 Mb)	S2	2.150	2.250	2.350	1	0.0846	0.0886	0.0925

3.3 VF BGA for 256 Mbit Package

Figure 5. VF BGA Package 256 Mb Drawing

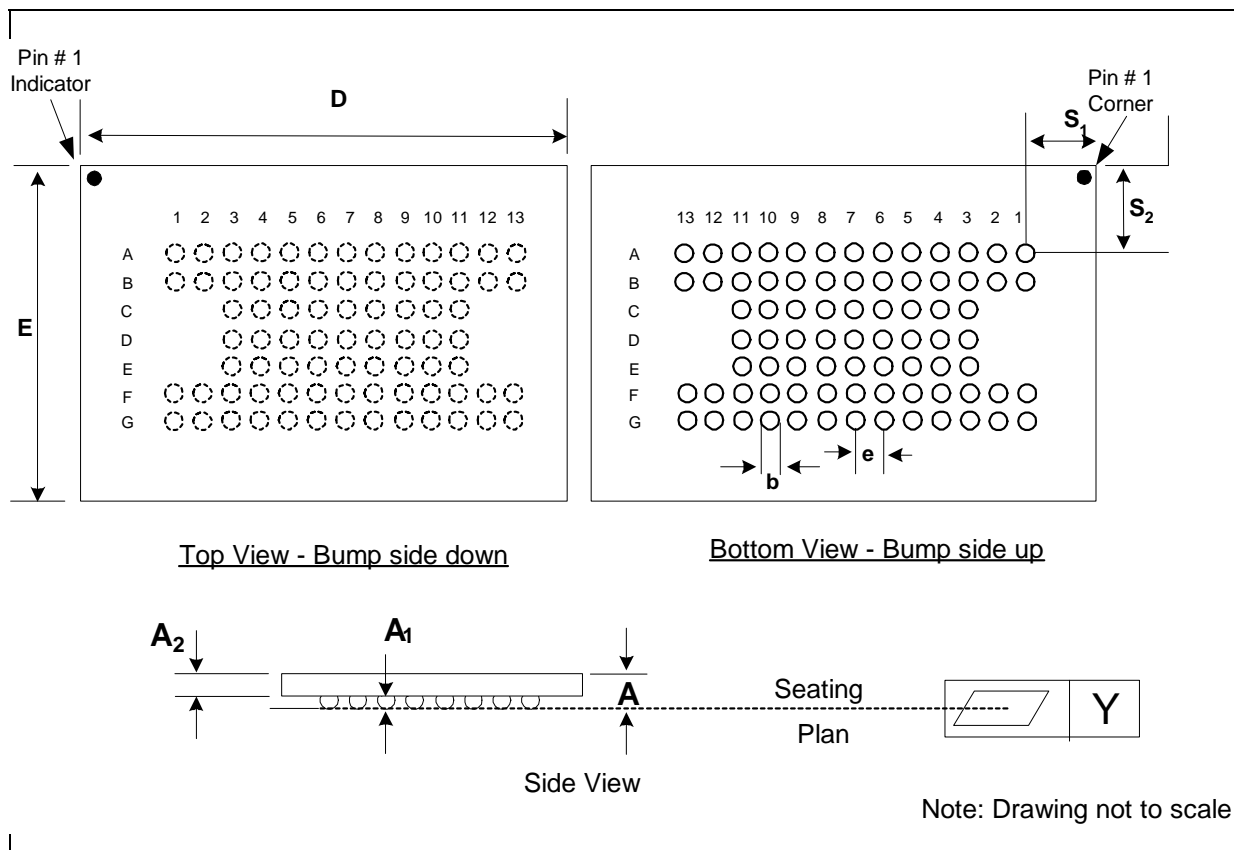


Table 3. VF BGA (256 Mb) Dimensions

	Symbol	Millimeters				Inches		
		Min	Nom	Max	Notes	Min	Nom	Max
Package Height	A			1.000				0.0394
Ball Height	A1	0.150				0.0059		
Package Body Thickness	A2		0.665				0.0262	
Ball (Lead) Width	b	0.325	0.375	0.425		0.0128	0.0148	0.0167
Package Body Width	D	14.400	14.500	14.600	1	0.5669	0.5709	0.5748
Package Body Length	E	8.900	9.000	9.100	1	0.3504	0.3543	0.3583
Pitch	[e]		0.750				0.0295	
Ball (Lead) Count	N		79				79	
Seating Plane Coplanarity	Y			0.100				0.0039
Corner to Ball A1 Distance Along D	S1	2.650	2.750	2.850	1	0.1043	0.1083	0.1122
Corner to Ball A1 Distance Along E	S2	2.150	2.250	2.350	1	0.0846	0.0886	0.0925

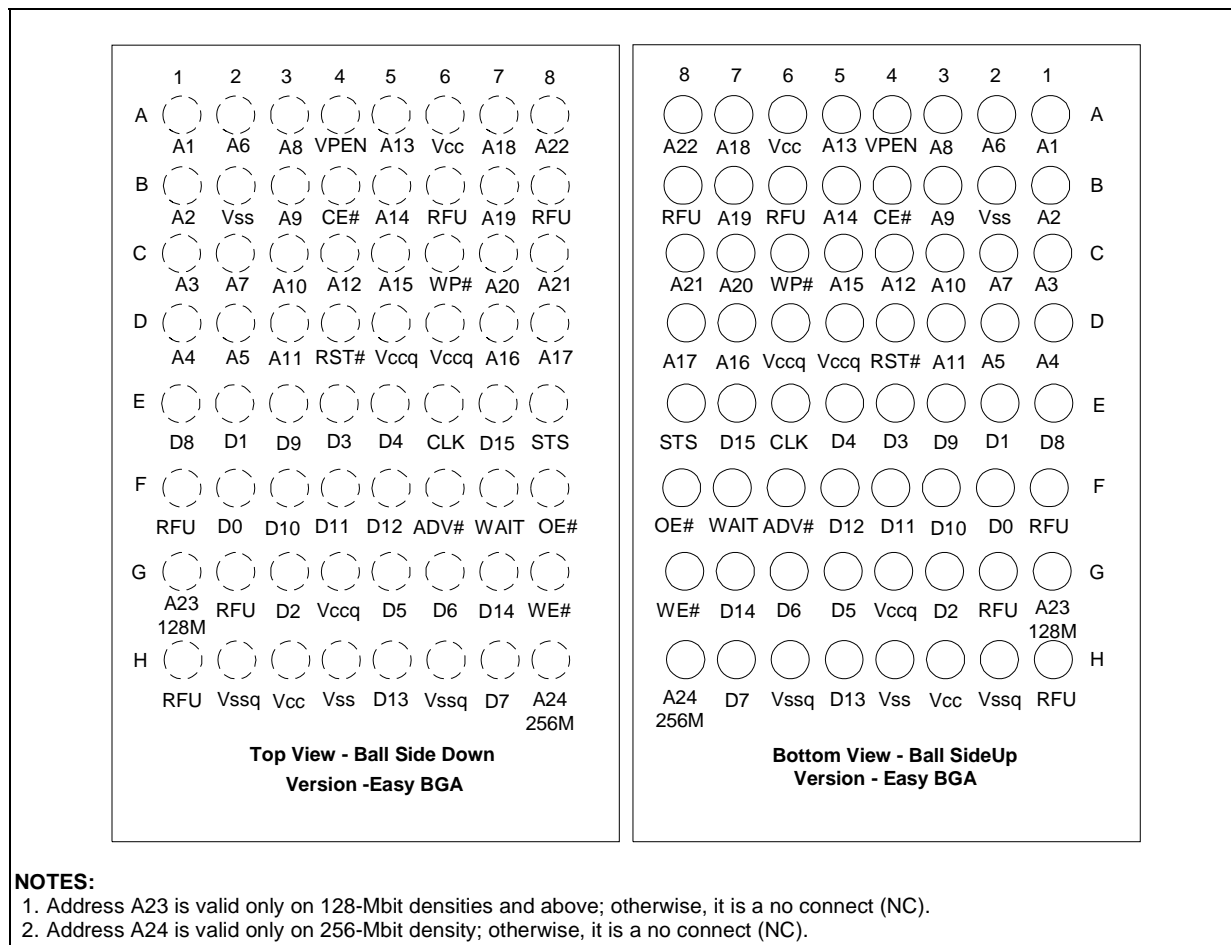
4.0 Ballout and Signal Description

The K3/K18 device is available in a 64-ball Easy BGA package for the 64-, 128-, and 256 Mbit densities. See [Figure 6](#).

This device is also available in a 56-ball VF BGA package for the 64- and 128-Mbit densities and a 79-ball VF BGA package for the 256-Mbit density. See [Figure 7 on page 18](#) and [Figure 8 on page 19](#).

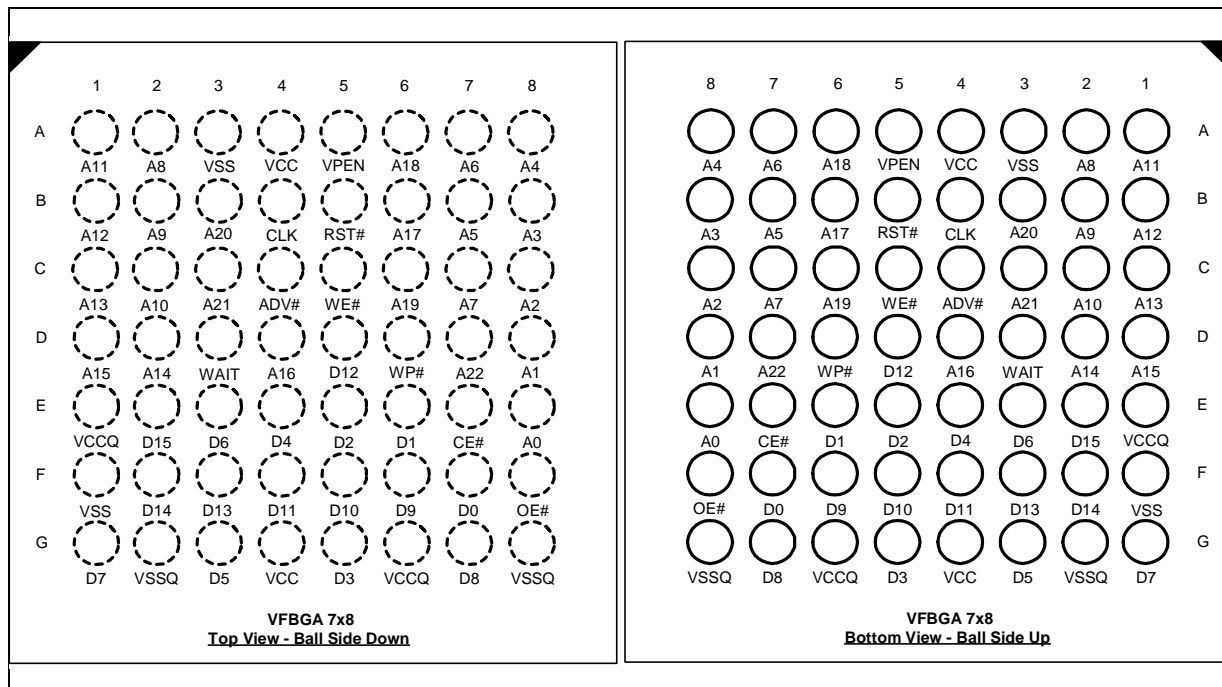
4.1 64-Ball Easy BGA Package for All Densities (1.0 mm Ball Pitch)

Figure 6. 64-Ball Easy BGA Package for All Available Densities (1.0 mm Ball Pitch)



4.2 56-Ball VF BGA Package for 64- and 128-Mbit Density (0.75 mm Ball Pitch)

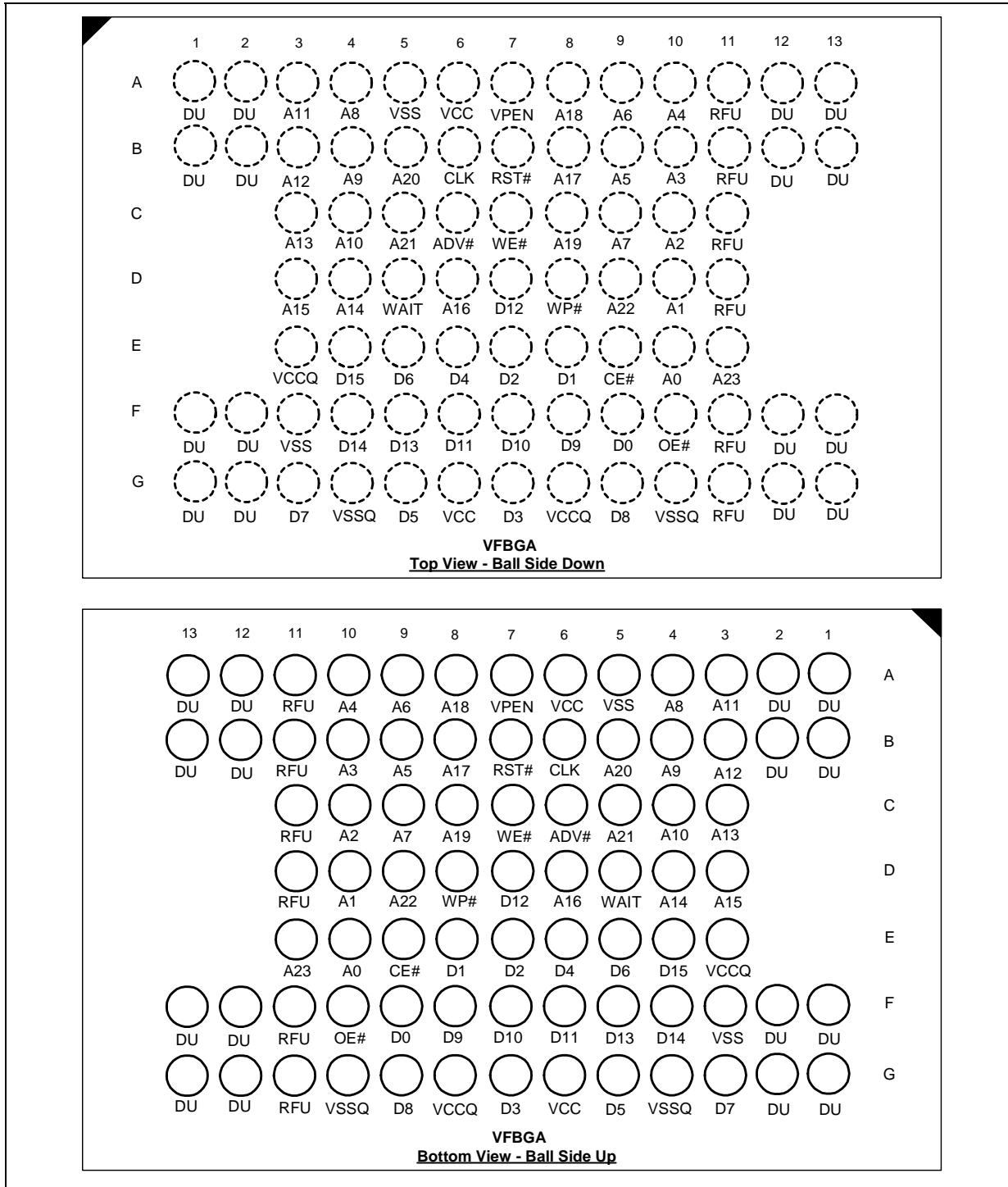
Figure 7. 56-Ball VF BGA Package 0.75 mm Ball Pitch (for 64- and 128-Mb Densities ONLY)



NOTE: Address A22 is only valid on 128-Mbit density; otherwise, it is a no connect (NC).

4.3 79-Ball VF BGA for 256-Mbit Density Package

Figure 8. 79-Ball VF BGA Package for 256-Mbit Density



4.4 Signal Descriptions

Table 4 describes the active signals used.

Table 4. Signal Descriptions

Sym	Type	Name and Function
A[A _{MAX} :A _{MIN}]	Input	ADDRESS: Device address. Address internally latched during read/write operations. See nomenclature Section 1.2 for A _{MAX} and A _{MIN} values.
D[15:0]	Input/Output	DATA I/O: Inputs data and commands during write operations, outputs data during read operations. Float when CE# or OE# are de-asserted. Data is internally latched during write operations.
CE#	Input	CHIP ENABLE: Active-low; CE#-low selects the device. CE#-high deselects the device, places it in standby mode, and places data and WAIT outputs in a High-Z state.
OE#	Input	OUTPUT ENABLE: Active-low; OE#-low enables the device's output data drivers during read cycles. OE#-high places the data outputs in a High-Z state.
WE#	Input	WRITE ENABLE: Active-low; WE# controls writes to the flash device. Address and data are latched on the rising edge of WE#.
RST#	Input	RESET: Active-low; resets internal circuitry and inhibits write operations. This provides data protection during power transitions. RST#-high enables normal operation. Exit from reset places the device in asynchronous read-array mode.
WP#	Input	WRITE PROTECT: Active-low; WP#-low enables the lock-down mechanism. Blocks locked down cannot be unlocked with the unlock command. WP#-high overrides the lock-down function enabling blocks to be erased or programmed through software.
ADV#	Input	ADDRESS VALID: Active-low; during synchronous read operations, addresses are latched on the rising edge of ADV# or on the rising (or falling) edge of CLK, whichever occurs first.
VPEN	Input	ERASE/PROGRAM/BLOCK LOCK ENABLE: Controls device protection. When V _{PEN} ≤ V _{PENLK} , flash contents are protected against Program and Erase.
CLK	Input	CLOCK: Synchronizes the device to the system's bus frequency in synchronous-read mode, and increments the internal address generator. During synchronous read operations, addresses are latched on ADV#'s rising edge or CLK's rising (or falling) edge, whichever occurs first. Connect this signal to VCC if the device will not be used in synchronous-read mode.
STS	Open Drain Output	STATUS: Indicates the status of the internal state machine. When configured in level mode (default mode), it acts as a RY/BY# pin. When configured in one of its pulse modes, it can indicate program and/or erase completion. For alternate configurations of the STATUS pin, see the configuration commands. STS is to be tied to V _{CCQ} with a pull-up resistor.
WAIT	Output	WAIT: Indicates invalid data in synchronous-read (burst) modes. WAIT is High-Z whenever CE# is de-asserted. WAIT is not gated by OE#.
VCC	Power	CORE POWER SUPPLY: Core (logic) source voltage. Writes to the flash array are inhibited when V _{CC} ≤ V _{LKO} . Device operation at invalid V _{CC} voltages should not be attempted.
VCCQ	Power	I/O POWER SUPPLY: I/O Output-driver source voltage.
VSS	Power	GROUND: Ground reference for device core power supply. Connect to system ground.
VSSQ	Power	I/O GROUND: I/O Ground reference for device I/O power supply. Connect to system ground.
DU	—	DO NOT USE: Do not use this ball. This ball should not be connected to any power supplies, signals or other balls and must be left floating.
NC	—	NO CONNECT: No internal connection; can be driven or floated.
RFU	—	RESERVED for FUTURE USE: Balls designated as RFU are reserved by Intel for future device functionality and enhancement.

5.0 Maximum Ratings and Operating Conditions

5.1 Absolute Maximum Ratings

The absolute maximum ratings are shown in Table 5.

Warning: Stressing the device beyond the “Absolute Maximum Ratings” may cause permanent damage. These are stress ratings only. Operation beyond the “Operating Conditions” is not recommended and extended exposure beyond the “Operating Conditions” may affect device reliability.

Table 5. Absolute Maximum Ratings

Parameter	Maximum Rating	Notes
Temperature under bias	-40 °C to +85 °C	
Storage temperature	-65 °C to +125 °C	
Voltage on any signal (except VCC and VCCQ)	-0.5 V to V _{CCQ} +0.5 V	1,2
VCC1 (K3) voltage	-0.2 V to +4.1 V	1
VCC2 (K18) voltage	-0.2 V to +3.8 V	
VCCQ1 (K3) voltage	-0.2 V to +4.1 V	1
VCCQ2 (K18) voltage	-0.2 V to +2.45 V	1
Output short circuit current	100 mA	3

NOTES:

- Specified voltages are with respect to V_{SS}. Minimum DC voltage is -0.5 V on input/output signals and -0.2 V on V_{CC} and V_{CCQ}. During transitions, this level may undershoot to -2.0 V for periods <20 ns. Maximum DC voltage on V_{CC} is V_{CC} +0.5 V, which, during transitions, may overshoot to V_{CC} +2.0 V for periods <20 ns. Maximum DC voltage on input/output signals and V_{CCQ} is V_{CCQ} +0.5 V, which, during transitions, may overshoot to V_{CCQ} +2.0 V for periods <20 ns.
- Program/erase voltage is normally 2.7 V–3.6 V.
- Output shorted for no more than one second. No more than one output shorted at a time.

5.2 Operating Conditions

Symbol	Parameter	Min	Max	Units
T _A	Operating Temperature	-40	+85	°C
V _{CC1}	Core Voltage (K3)	2.70	3.60	V
V _{CC2}	Core Voltage (K18)	2.70	3.30	V
V _{CCQ1}	Vccq I/O Supply voltage (K3)	2.375	3.60	V
V _{CCQ2}	Vccq I/O Supply voltage (K18)	1.65	1.95	V
Block Erase Cycles	All Blocks, V _{CC} = 3 V	100,000		Cycles

6.0 Electrical Specifications

6.1 DC Current Characteristics

Table 6. DC Current Characteristics

V_{CC}			2.7 V – 3.3 V		2.7 V – 3.6 V					
V_{CCQ}			1.65 V – 1.95 V		2.375 V – 3.6 V					
Sym	Parameter		Notes	Typ	Max	Typ	Max	Unit	Test Condition	
I_{LI}	Input Load Current		1		± 1		± 1	μA	$V_{CC} = V_{CCMAX}$, $V_{CCQ} = V_{CCQMAX}$, $V_{IN} = V_{CCQ}$ or GND	
I_{LO}	Output Leakage Current		1		± 10		± 10	μA	$V_{CC} = V_{CCMAX}$, $V_{CCQ} = V_{CCQMAX}$, $V_{IN} = V_{CCQ}$ or GND	
I_{CCS}	V_{CC} Standby	64 Mbit, 128 Mbit	1, 2, 3, 4	30	55	30	55	μA	CMOS Inputs, $V_{CC} = V_{CCMAX}$, $V_{CCQ} = V_{CCQMAX}$, Device is Disabled $RST\# = V_{CCQ} \pm 0.2V / GND \pm 0.2V$	
		256 Mbit		45	80	45	80	μA		
I_{CCR}	Average V_{CC} Read Current	Single Word Read	1, 3, 4, 5	10	73	10	78	mA	$V_{CC} = V_{CCMAX}$, $t_{ACC} = t_{AVQV}$	
		Asynchronous Page Mode		16	28	18	30	mA	8 Word Read $t_{ACC} = t_{AVQV}$, $t_{APA} = 25$ ns, $V_{CC} = V_{CCMAX}$	
		Synchronous Burst		Burst length = 8	24	38	32	46	mA	f = 66 MHz(K3), 50 MHz(K18) $V_{CC} = V_{CCMAX}$ CE# = V_{IL} , OE# = V_{IH} , Inputs = V_{IH} or V_{IL}
				Burst length = 16	28	40	36	48	mA	
I_{CCW}	V_{CC} Program Current		1, 4, 6, 7	50	80	40	70	mA	CMOS Inputs, $V_{PEN} = V_{CC}$	
I_{CCE}	V_{CC} Block Erase Current		1, 4, 6, 7	50	80	40	70	mA	CMOS Inputs, $V_{PEN} = V_{CC}$	
I_{CCWS} , I_{CCES}	V_{CC} Program Suspend or Block Erase Suspend Current		1, 4, 6, 7		20		10	mA	Device is enabled	

NOTES:

- All currents are RMS unless noted. Typical values at $V_{CC} = 3$ V, $T_A = +25^\circ C$, best-case address pattern. Maximum values at $V_{CC} = 3.6$ V, worst-case address pattern.
- Includes STS.
- CMOS inputs/outputs are either $V_{CC} \pm 0.2$ V or $V_{SS} \pm 0.2$ V.
- Current values are specified over a specific temperature range ($-40^\circ C$ to $+85^\circ C$).
- Sampled, not 100% tested.
- I_{CCES} , I_{CCWS} are specified with device deselected. If device is read while in erase suspend/program suspend, current is I_{CCES} plus I_{CCR} or I_{CCWS} plus I_{CCR} .
- $V_{PEN} < V_{PENLK}$ inhibits block erase, program and lock-bit operations. Don't use V_{PEN} outside its valid ranges.

Table 7. DC Voltage Characteristics

V_{CC}			2.7 V – 3.3 V		2.7 V – 3.6 V				
V_{CCQ}			1.65 V – 1.95 V		2.375 V – 3.6 V				
Sym	Parameter ⁽¹⁾		Note	Min	Max	Min	Max	Unit	Test Condition
V_{IL}	Input Low Voltage	CMOS	7	0	0.4	0	0.4	V	
V_{IH}	Input High Voltage	CMOS	7	$V_{CCQ} - 0.4$	V_{CCQ}	2.3	V_{CCQ}	V	
V_{OL}	Output Low Voltage	CMOS	2, 4		0.2		0.2	V	$V_{CC} = V_{CCMIN}$, $V_{CCQ} = V_{CCQMIN}$, $I_{OH} = 100 \mu A$
V_{OH}	Output High Voltage	CMOS	2, 4	$V_{CCQ} - 0.2$		$V_{CCQ} - 0.2$		V	$V_{CC} = V_{CCMIN}$, $V_{CCQ} = V_{CCQMIN}$, $I_{OH} = -100 \mu A$
V_{PENLK}	V_{PEN} Lock-Out during normal operations		3, 5		1.0		1.0	V	
V_{PENH}	V_{PEN} during Block Erase, Program or Lock-Bit operations		3, 5	1.65	1.95	2.7	3.6	V	
V_{LKO}	V_{CC} Lockout Voltage		3, 6	1.8		1.8		V	
V_{CCQLKO}	V_{CCQ} Lockout Voltage		3	1.0		1.0		V	

NOTES:

1. All currents are RMS unless noted. Typical values at typical V_{CC} , $T_A = +25^\circ C$.
2. Includes STS.
3. Sampled, not 100% tested.
4. I_{CCES} , I_{CCWS} are specified with device deselected. If device is read while in erase suspend/program suspend, current is I_{CCES} plus I_{CCR} or I_{CCWS} plus I_{CCR} .
5. $V_{PEN} < V_{PENLK}$ inhibits block erase, program and lock-bit operations. Don't use V_{PEN} outside its valid ranges.
6. Block erases, programming and lock-bit configurations are inhibited when $V_{CC} < V_{LKO}$, and not guaranteed in the range between V_{LKOMIN} and V_{CCMIN} , and above V_{CCMAX} .
7. V_{IL} can undershoot to $-0.4V$ and V_{IH} can overshoot to $V_{CCQ} + 0.4V$ for durations of 20 ns or less.

7.0 AC Characteristics

7.1 Read Operations

Table 8. AC Read Characteristics (Sheet 1 of 2)

VCC					2.7 V - 3.3 V		2.7 V - 3.6 V		
VCCQ					1.65 V - 1.95V		2.375 V - 3.6 V		
Num	Sym	Parameter ⁽³⁾	Density	Note	Min	Max	Min	Max	Unit
Asynchronous Specifications									
R1	t_{AVAV}	Read cycle time	64 Mbit		110		110		ns
			128 Mbit		115		115		ns
			256 Mbit		120		120		ns
R2	t_{AVQV}	Address to output delay	64 Mbit	6		110		110	ns
			128 Mbit			115		115	ns
			256 Mbit			120		120	ns
R3	t_{ELQV}	CE# low to output delay	64 Mbit	3		110		110	ns
			128 Mbit			115		115	ns
			256 Mbit			120		120	ns
R4	t_{GLQV}	OE# low to output delay		3		30		25	ns
R5	t_{PHQV}	RST# high to output delay	64 Mbit			190		180	ns
			128 Mbit			220		210	ns
			256 Mbit			220		210	ns
R6	t_{ELQX}	CE# low to output in Low-Z			0		0		ns
R7	t_{GLQX}	OE# low to output in Low-Z		3	0		0		ns
R8	t_{EHQZ}	CE# high to output in High-Z		5		25		25	ns
R9	t_{GHQZ}	OE# high to output in High-Z		5		25		25	ns
R10	t_{OH}	Output hold from first occurring address, CE# or OE# change		5	0		0		ns
R11	t_{EHEL}	CE# high to CE# low		1	0		0		ns
R12	t_{ELTLH}	CE# low to WAIT low				30		25	ns
R13	t_{EHTZ}	CE# high to WAIT High-Z				30		25	ns
Latching Specifications									
R101	t_{AVVH}	Address setup to ADV# high			9		7		ns
R102	t_{ELVH}	CE# low to ADV# high			9		7		ns
R103	t_{VLQV}	ADV# low to output delay	64 Mbit			110		110	ns
			128 Mbit			115		115	ns
			256 Mbit			120		120	ns

Table 8. AC Read Characteristics (Sheet 2 of 2)

VCC					2.7 V - 3.3 V		2.7 V - 3.6 V		Unit
VCCQ					1.65 V - 1.95V		2.375 V - 3.6 V		
Num	Sym	Parameter ⁽³⁾	Density	Note	Min	Max	Min	Max	
R104	t _{VLVH}	ADV# pulse width low			12		10		ns
R105	t _{VHVL}	ADV# pulse width high			12		10		ns
R106	t _{VHAX}	Address hold from ADV# high		4	10		8		ns
R108	t _{APA}	Page address access		6		30		25	ns
Clock Specifications									
R200	f _{CLK}	CLK frequency				50		66	MHz
R201	t _{CLK}	CLK period		7	20		15		ns
R202	t _{CH/L}	CLK high/low time		7	7		4.5		ns
R203	t _{CHCL}	CLK fall/rise time		7		3		3	ns
Synchronous Specifications									
R301	t _{AVCH}	Address valid setup to CLK			9		7		ns
R302	t _{VLCH}	ADV# low setup to CLK			9		7		ns
R303	t _{ELCH}	CE# low setup to CLK			9		7		ns
R304	t _{CHQV}	CLK to output delay		7		15		13	ns
R305	t _{CHQX}	Output hold from CLK			3		3		ns
R306	t _{CHAX}	Address hold from CLK		4	10		8		ns
R307	t _{CHTL/H}	CLK to WAIT delay		7, 8		15		13	ns
R312	t _{CHVL}	CLK to ADV# low			3		3		ns

NOTES:

1. CE# high between synchronous reads = 15 ns. Data bus read voltage is $\leq V_{CCQ1}$.
2. See Figure 17, "AC Input/Output Reference Waveform" on page 32 for timing measurements and maximum allowable input slew rate.
3. OE# may be delayed up to t_{ELQV}-t_{GLQV} after CE# low without impact on t_{ELQV}.
4. Address hold in synchronous burst-mode is t_{CHAX} or t_{VHAX}, whichever timing specification is satisfied first.
5. Sampled, not 100% tested.
6. For devices configured to standard word read mode, R108(t_{APA}) will equal R2(t_{AVQV}).
7. The clock duty cycle should be 50% (approx.).
8. Applies only to subsequent synchronous reads.

Figure 9. Single Word Asynchronous Read Waveform

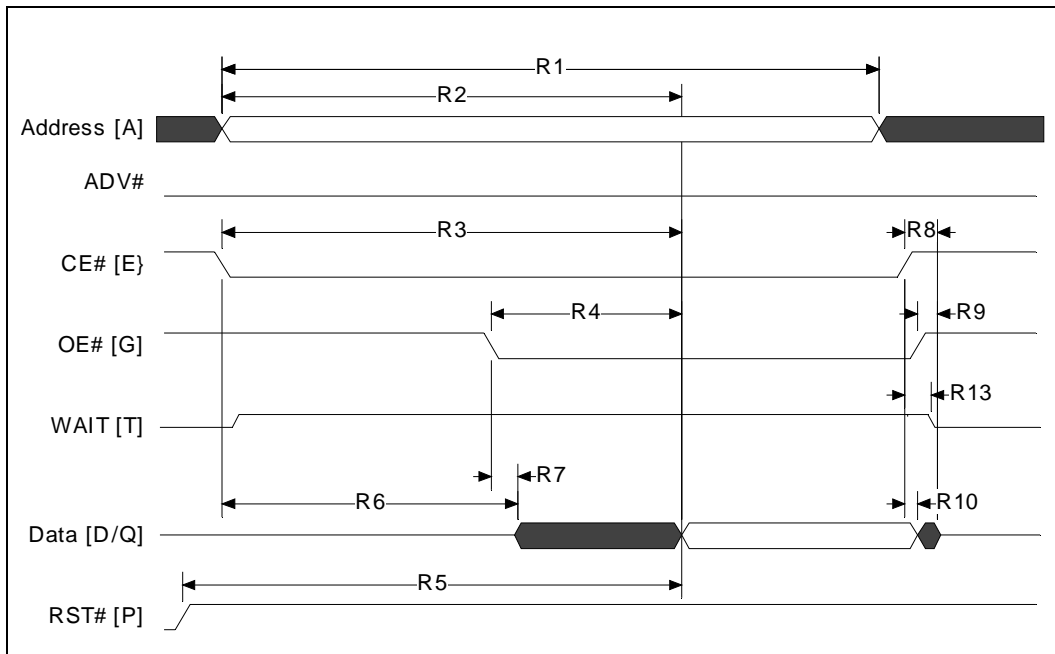


Figure 10. Page Mode Read Waveform

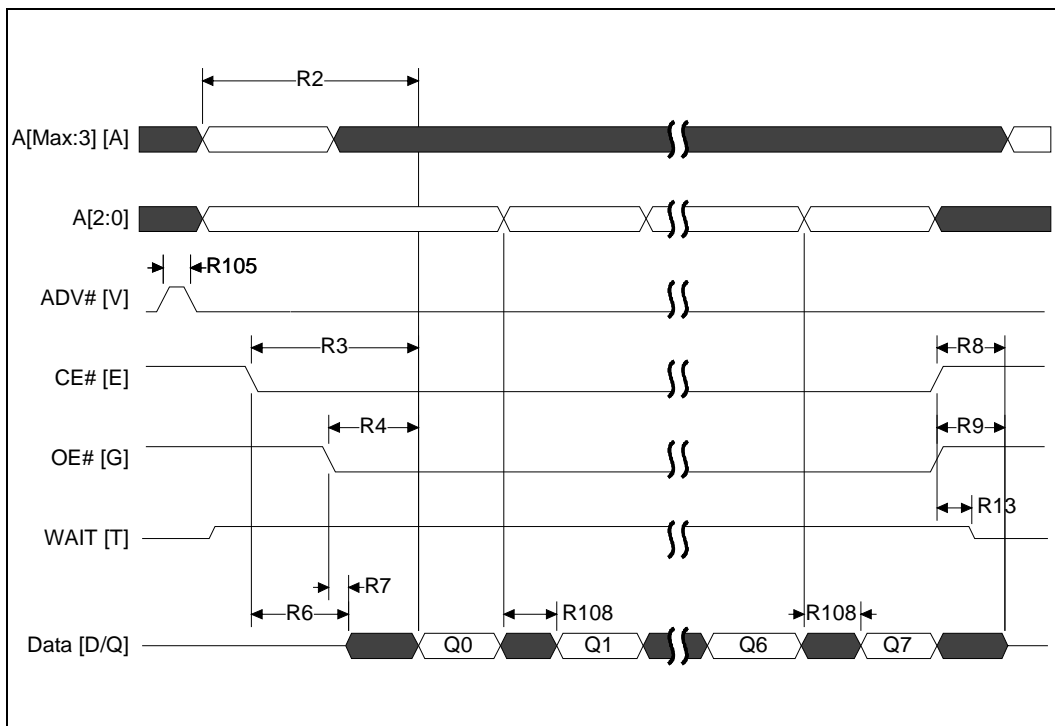
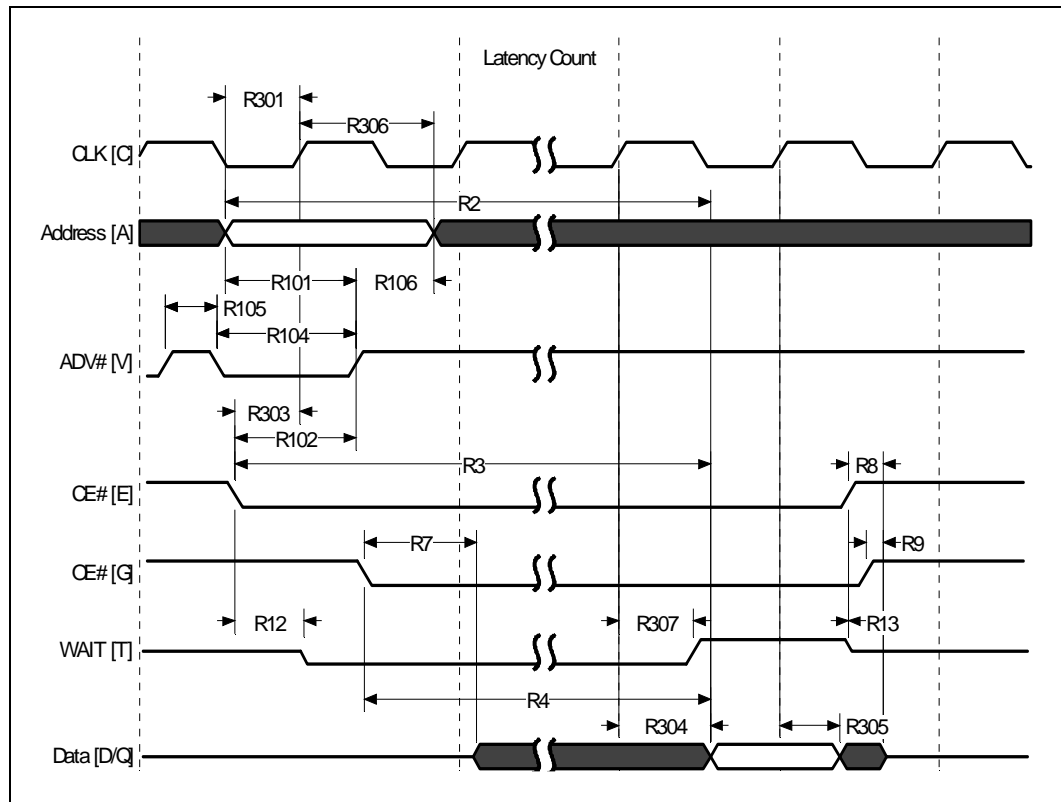
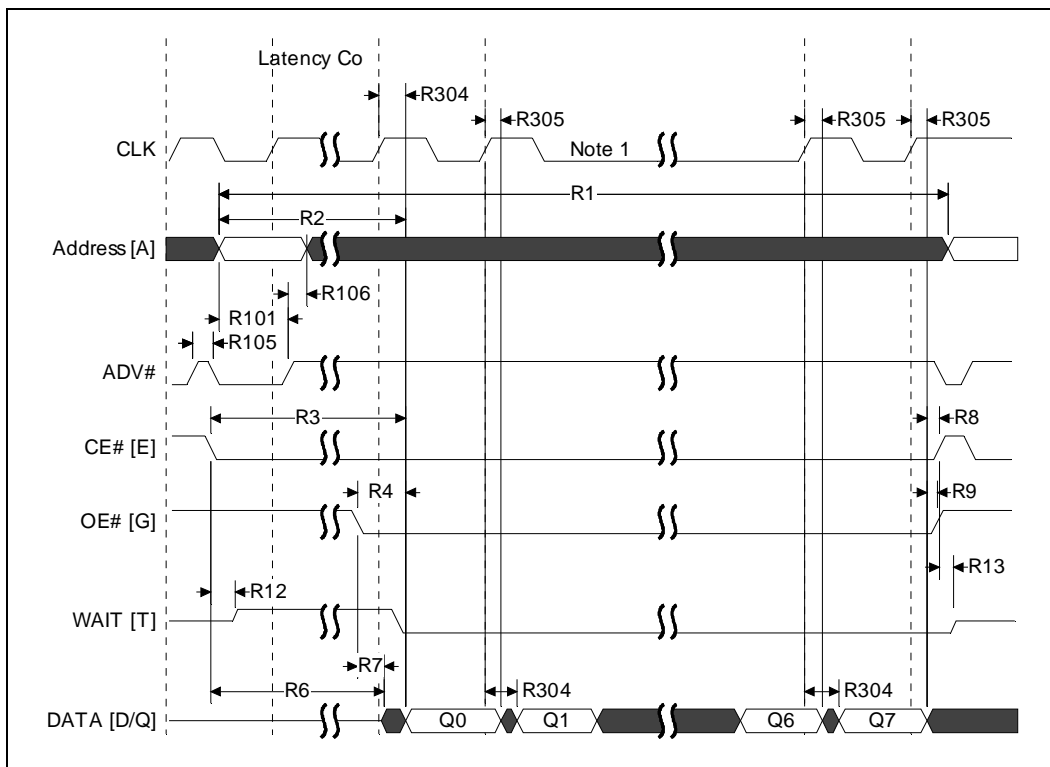


Figure 11. Single Word Burst Read Waveform



NOTE: WAIT (shown active low) can be configured to assert either during, or one clock before, valid data.

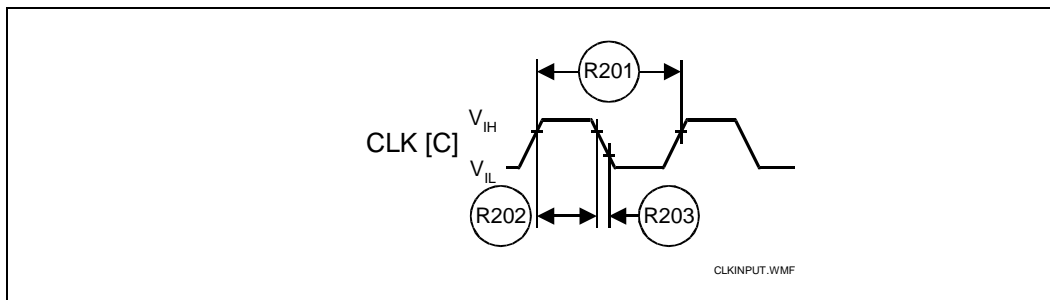
Figure 12. 8 Word Synchronous Burst Read Waveform



NOTES:

1. Section 4.9.13, "First Access Latency Count (CR.11-13)" on page 38 describes how to insert clock cycles during the initial access.
2. WAIT (shown active high) can be configured to assert either during or one clock before valid data.

Figure 13. Clock Input AC Waveform



7.2 Write Operation

Table 9. Write Characteristics

VCC					2.7 - 3.3 V	2.7 - 3.6 V	
VCCQ					1.65 - 1.95 V	2.375 - 3.6 V	
Num	Sym	Parameter ⁽¹⁾	Density	Notes	Min	Min	Unit
W1	t _{PHWL}	RST# high recovery to WE# low	64 Mbit		190	180	ns
			128 Mbit		220	210	ns
			256 Mbit	2	220	210	ns
W2	t _{ELWL}	CE# setup to WE# low			0	0	ns
W3	t _{WLWH}	WE# write pulse width low		3	60	60	ns
W4	t _{DVWH}	Data setup to WE# high			60	60	ns
W5	t _{AVWH}	Address setup to WE# high			55	55	ns
W6	t _{WHEH}	CE# hold from WE# high			0	0	ns
W7	t _{WHDX}	Data hold from WE# high			0	0	ns
W8	t _{WHAX}	Address hold from WE# high			0	0	ns
W9	t _{WHWL}	WE# pulse width high		4, 5	35	30	ns
W10	t _{VPWH} (t _{VPEH})	V _{PEN} Setup to WE# (CE#) Going High			0	0	ns
W11	t _{QVVL}	V _{PEN} Hold from Valid SRD, STS Going High		3, 7	0	0	
W12	t _{QVBL}	WP# hold from Status read		2, 3, 6	0	0	ns
W13	t _{BHWH}	WP# setup to WE# high		2	200	200	ns
W14	t _{WHGL}	Write recovery before read			35	35	ns
W16	t _{WHQV}	WE# high to data valid		2	t _{AVQV} +40	t _{AVQV} +40	ns

NOTES:

- Read timing characteristics during block erase, program and lock-bit operations are the same as during read-only operations. Refer to AC Characteristics - Read-Only Operations.
- A write operation can be initiated or terminated with either CE# or WE#.
- Sampled, not 100% tested.
- Write pulse width low (t_{WLWH}) is defined from CE# or WE# going low (whichever goes low last) to CE# or WE# going high (whichever goes high first). Hence, t_{WLWH} = t_{ELEH} = t_{WLEH} = t_{ELWH}.
- Write pulse width high (t_{WHWL}) is defined from CE# or WE# going high (whichever goes high first) to CE# or WE# going low (whichever goes low last). Hence, t_{WHWL} = t_{EHEL} = t_{WHEL} = t_{EHWL}.
- For array access, t_{AVQV} is required in addition to t_{WHGL} for any accesses after a write.
- STS timings are based on STS configured in its RY/BY# default mode.

Figure 14. Write to Write Waveform

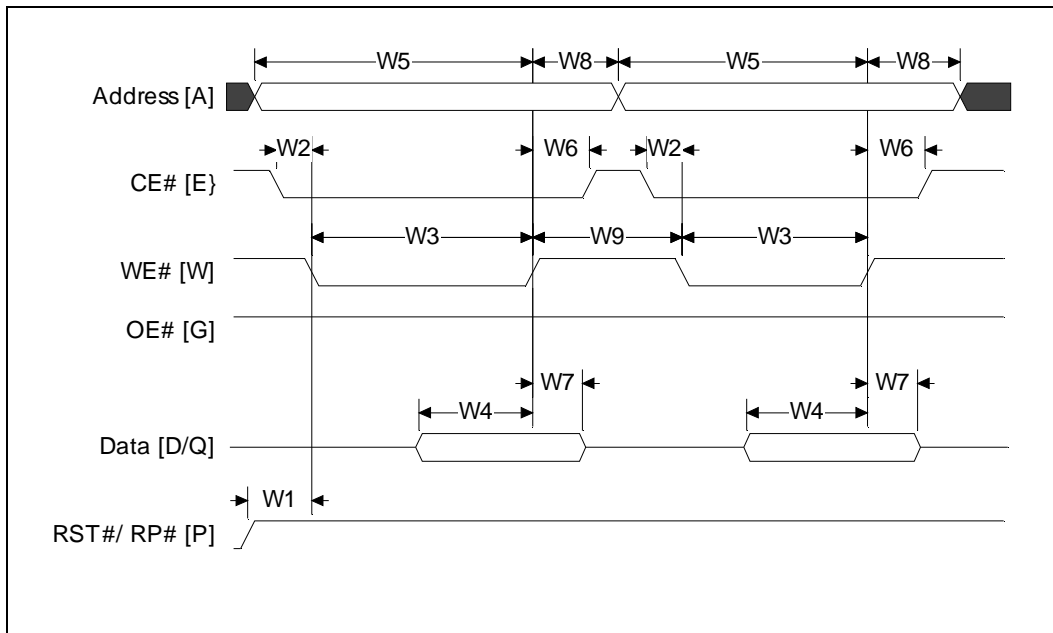


Figure 15. Asynchronous Read to Write Waveform

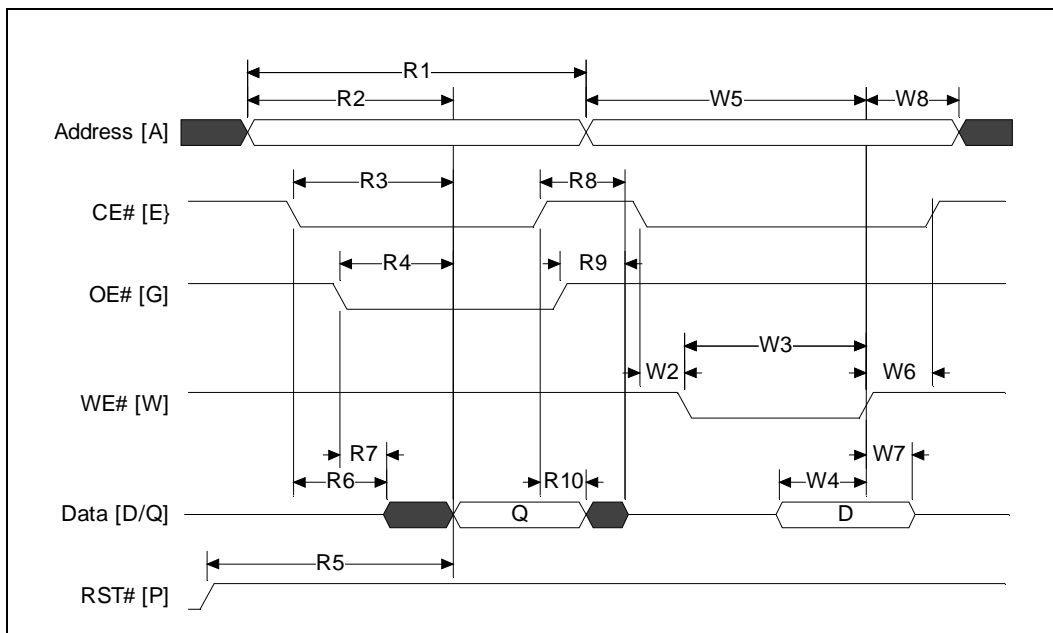
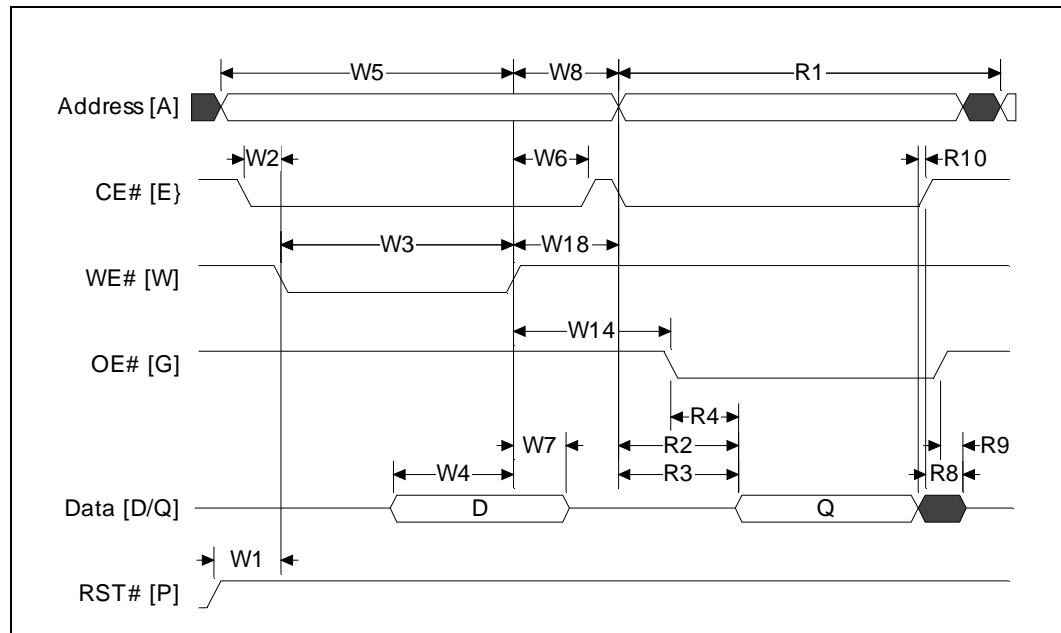


Figure 16. Asynchronous Write to Read Waveform



7.3 Block Erase and Program Operation Performance

Table 10. Block Erase and Program Operation Performance

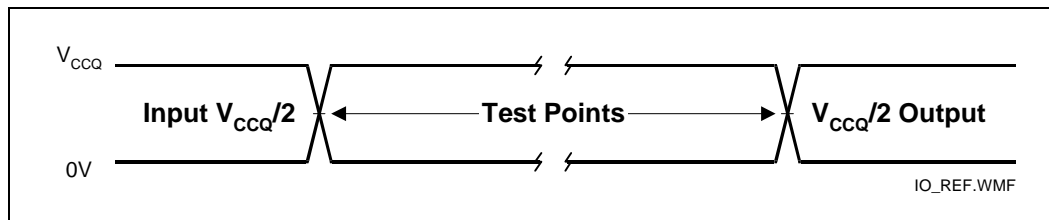
#	Sym	Parameter	Notes	Min	Typ	Max	Unit
W0	t_{WHQV1}, t_{EHQV1}	Write Buffer Program Time (Time to program 64 bytes/32 words)	4, 5, 6		320	960	μ s
	t_{WHQV2}, t_{EHQV2}	Word Program Time (Using Word Program Command)	4		150	450	μ s
	t_{WHQV3}, t_{EHQV3}	Block Program Time (Using Write-to- Buffer Command)	4		0.7	2.1	sec
	t_{BBWB}	Buffered-EFP Buffer Write Time	1, 3, 4		288	864	μ s
	t_{BWB}	Buffered-EFP Block Write Time	1, 3, 4		0.58	1.7	sec
	$t_{BEFP-SETUP}$	Buffered-EFP Set-up Time	1, 3, 4		N/A	5.0	μ s
	t_{WHQV4}, t_{EHQV4}	Block Erase Time	4		1.0	4.0	sec
	t_{WHRH1}, t_{EHRH1}	Program Suspend Latency Time to Read			20	25	μ s
	t_{WHRH}, t_{EHRH}	Erase Suspend Latency Time to Read			20	25	μ s
WY	t_{STS}	STS Pulse Width Low Time	4		250		ns

NOTES:

1. Typical values measured at $T_A = +25^\circ\text{C}$ and nominal voltages. Assumes corresponding lock-bits are not set. Subject to change based on device characterization.
2. These performance numbers are valid for all speed versions.
3. Sampled but not 100% tested.
4. Excludes system level overhead.
5. These values are valid when the buffer is full, and the start address is aligned on 32-bit boundary.
6. Effective word program time (t_{WHQV1}, t_{EHQV1}) is 10.0 μ s/word (typ).

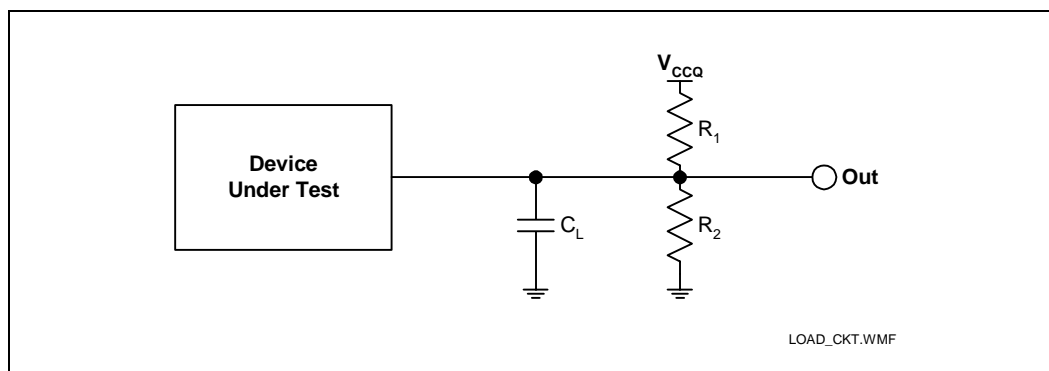
7.4 AC Test Conditions

Figure 17. AC Input/Output Reference Waveform



NOTE: AC test inputs are driven at V_{CCQ} for Logic “1” and 0.0 V for Logic “0.” Input/output timing begins or ends at $V_{CCQ}/2$. Input rise and fall times (10% to 90%) < 5 ns. Worst case speed occurs at $V_{CC} = V_{CCMIN}$.

Figure 18. Transient Equivalent Testing Load Circuit



NOTE: C_L included jig capacitance.

Table 11. Test Configuration Component Value for Worst Case Speed Conditions

Test Configuration	C_L (pF)	R_1	R_2
V_{CCQMIN} Standard Test	30	25K	25K

NOTE: C_L includes jig capacitance.

7.5 Capacitance

Table 12. Capacitance

Sym	Parameter ⁽¹⁾	Typ	Max	Unit	Condition
C_{IN}	Input Capacitance	6	8	pF	$V_{IN} = 0.0 V$
C_{OUT}	Output Capacitance	8	12	pF	$V_{OUT} = 0.0 V$

NOTES:

- $T_A = +25^\circ C$, $f = 1 MHz$.
- Sampled, not 100% tested.

8.0 Power and Reset

This section provides an overview of some system level considerations in regards to the flash device. This section provides a brief description of power-up, power-down, decoupling and reset design considerations.

8.1 Power-Up/Down Characteristics

In order to prevent any condition that may result in a spurious write or erase operation, it is recommended to power-up and power-down V_{CC} and V_{CCQ} together. It is also recommended to power-up V_{PEN} with or slightly after V_{CC} . Conversely, V_{PEN} must power down with or slightly before V_{CC} .

8.2 Power Supply Decoupling

When the device is enabled, many internal conditions change. Circuits are energized, charge pumps are switched on, and internal voltage nodes are ramped. All of this internal activities produce transient signals. The magnitude of the transient signals depends on the device and system loading. To minimize the effect of these transient signals, a 0.1 μF ceramic capacitor is required across each V_{CC}/V_{SS} and V_{CCQ}/V_{SSQ} signal. Capacitors should be placed as close as possible to device connections.

Additionally, for every eight flash devices, a 4.7 μF electrolytic capacitor should be placed between V_{CC} and V_{SS} at the power supply connection. This 4.7 μF capacitor should help overcome voltage slumps caused by PCB (print circuit board) trace inductance.

8.3 Reset Characteristics

By holding the flash device in reset during power-up and power-down transitions, invalid bus conditions may be masked. The flash device enters reset mode when $RST\#$ is driven low. In reset, internal flash circuitry is disabled and outputs are placed in a high-impedance state. After return from reset, a certain amount of time is required before the flash device is able to perform normal operations. After return from reset, the flash device defaults to asynchronous page mode. If $RST\#$ is driven low during a program or erase operation, the program or erase operation will be aborted and the memory contents at the aborted block or address are no longer valid. See [Figure 19, “Reset Operation Waveforms” on page 34](#) for detailed information regarding reset timings.

8.4 Reset Operation

Figure 19. Reset Operation Waveforms

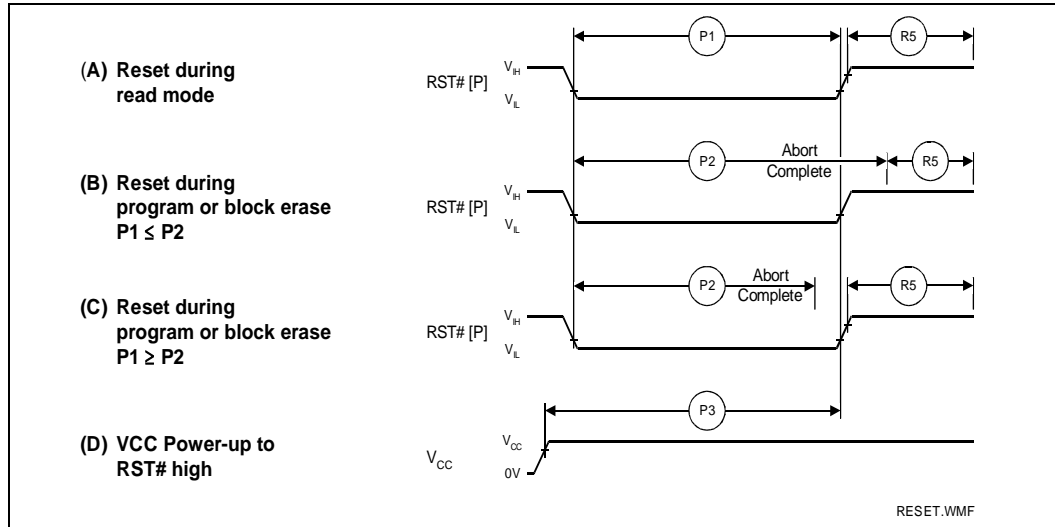


Table 13. Reset Specifications

Num	Symbol	Parameter	Notes	Min	Max	Unit
P1	t_{PLPH}	RST# pulse width low	1,2,3,4	100		ns
P2	t_{PLRH}	RST# low to device reset during erase	1,3,4,7		20	μ s
		RST# low to device reset during program	1,3,4,7		10	
P3	t_{VCCPH}	V_{CC} Power Valid to RST# de-assertion (high)	1,4,5,6	60		

NOTES:

1. These specifications are valid for all product versions (packages and speeds).
2. The device may reset if t_{PLPH} is $<t_{PLPH}$ MIN, but this is not guaranteed.
3. Not applicable if RST# is tied to V_{CC} .
4. Sampled, but not 100% tested.
5. If RST# is tied to the V_{CC} supply, device will not be ready until t_{VCCPH} after $V_{CC} \geq V_{CC}$ min.
6. If RST# tied to any supply/signal with V_{CCQ} voltage levels, the RST# input voltage must not exceed V_{CC} until $V_{CC} \geq V_{CC}(\text{min})$.
7. Reset completes within t_{PLPH} if RST# is asserted while no erase or program operation is executing.

9.0 Bus Operations

This section provides an overview of device bus operations. The on-chip Write State Machine (WSM) manages all block-erase and word-program algorithms. The system CPU provides control of all in-system read, write, and erase operations of the device via the system bus.

Device commands are written to the Command User Interface (CUI) to control all of the flash memory device's operations. The CUI does not occupy an addressable memory location; it is the mechanism through which the flash device is controlled.

9.1 Bus Operations Overview

Bus cycles to and from the device conform to standard microprocessor bus operations. Table 14 summarizes the bus operations and the voltage levels that must be applied to the device control signals when operating within each device mode. Whenever CE# is asserted, the device is in an active state; it is selected and its internal circuits are active. OE# and WE# determine whether D[15:0] are outputs or inputs, respectively.

Table 14. Bus Operations

Mode	RST#	CE#	OE# ⁽¹⁾	WE# ⁽¹⁾	ADV#	WAIT	V _{PEN}	Data	STS (default mode)	Notes
Synch Array Read	V _{IH}	Enabled	V _{IL}	V _{IH}	X	Valid	X	D _{OUT}	High-Z	
Asynch. Reads and Synch. Status, Query and Identifier Reads	V _{IH}	Enabled	V _{IL}	V _{IH}	X	Driven	X	D _{OUT}	High-Z	2
Output Disable	V _{IH}	Enabled	V _{IH}	V _{IH}	X	Driven	X	High-Z	High-Z	
Standby	V _{IH}	Disabled	X	X	X	High-Z	X	High-Z	High-Z	
Reset	V _{IL}	X	X	X	X	High-Z	X	High-Z	High-Z	
CUI Command Write	V _{IH}	Enabled	V _{IH}	V _{IL}	X	Driven	X	D _{IN}	High-Z	
Array Writes	V _{IH}	Enabled	V _{IH}	V _{IL}	X	Driven	V _{PENH}	D _{IN}	V _{IL}	3, 4

NOTES:

1. OE# and WE# should never be asserted simultaneously, but if done, OE# overrides WE#.
2. Refer to DC Characteristics. When $V_{PEN} \leq V_{PENLK}$, memory contents can be read but not altered.
3. X should be V_{IL} or V_{IH} for the control pins and V_{PENLK} or V_{PENH} for V_{PEN}. For outputs, X should be V_{OL} or V_{OH}.
4. Array writes are either program or erase operations.

9.1.1 Read Mode

To perform a bus read operation, CE# and OE# must be asserted. CE# is the device-select control; when active, it enables the flash memory device. OE# is the data-output control; when active, the addressed flash memory data is driven onto the I/O bus. For all read states, WE# and RST# must be de-asserted. See Section 7.1, “Read Operations” on page 24. Refer to Section 10.0, “Read Modes” on page 39 for details on reading from the flash array, and refer to Section 14.0, “Special Modes” on page 56 for details regarding all other available read states.

9.1.2 Write/Program

To perform a bus write operation, both CE# and WE# are asserted, and OE# is de-asserted. All device write operations are asynchronous, with CLK being ignored. During a write operation, address and data are latched on the rising edge of WE# or CE#, whichever occurs first. See [Table 15, “Command Bus Definitions” on page 37](#) for bus cycle commands. See [Section 7.2, “Write Operation” on page 29](#).

Write operations with invalid V_{CC} and/or V_{PEN} voltages can produce spurious results and should not be attempted.

9.1.3 Output Disable

When OE# is de-asserted, device outputs, D[15:0], are disabled and placed in a high-impedance state.

9.1.4 Standby

When CE# is de-asserted, the device is deselected and placed in standby, substantially reducing power consumption. In standby, the data outputs are placed in a high-impedance state independent of the level placed on OE#. If the device is de-selected (CE# de-asserted) during a program or erase operation, it will continue to consume active power until the program or erase operation is completed. There is no additional latency for subsequent read operations.

9.1.5 Reset

After initial power-up or reset, the device defaults to Read Array mode and the device status register is set to 0x80. If already in Read Array mode, asserting RST# de-energizes all internal circuits, and places the output drivers in a high-impedance state. After returning from reset (RST# de-asserted) a minimum amount of time is required before the initial read access outputs valid data. Also, a minimum delay is required after a reset before a write cycle can be initiated. After this wake-up interval has passed, normal operation is restored. See [Section 7.1, “Read Operations” on page 24](#) for reset timing details.

Note: If RST# is asserted during a program or erase operation, the operation will be aborted and the memory contents at the aborted location (for a program) or block (for an erase) are no longer valid, since the data may have been only partially written or erased.

When RST# is asserted, the device shuts down the operation in progress, a process which takes a minimum amount of time to complete. When RST# has been de-asserted, the device will be reset to read array mode. If the system is returning from an aborted program or erase operation, a minimum amount of time must be satisfied before a read or write operation is initiated.

As with any automated device, it is important to assert RST# when the system is reset. When the system comes out of reset, the system processor will attempt to read from the flash memory if it is the system boot device. Automated flash memories provide status information when read during program or block erase operations. If a CPU reset occurs with no flash memory reset, improper CPU initialization may occur because the flash memory may be providing status information rather than array data. Intel® Flash memory devices allow proper CPU initialization following a system reset through the use of the RST# input. RST# should be controlled by the same low-true reset signal that resets the system CPU.

9.2 Device Commands

Device operations are initiated by writing specific device commands to the Command User Interface (CUI). (See [Table 15](#).)

Table 15. Command Bus Definitions (Sheet 1 of 2)

	Command	Bus Cycles	First Bus Cycle			Second Bus Cycle		
			Type	Addr	Data	Type	Addr	Data
Read	Read Array	≥1	Write	Any Address	0xFF	Read	Address of memory to be read	Array Data
	Read Identifier	≥2	Write	Any Address	0x90	Read	Identifier Code Address	Identifier Code Data
	Read Query (CFI)	≥2	Write	Any Address	0x98	Read	Query Code Address	Query Code Data
	Read Status Register	2	Write	Address within Block	0x70	Read	Address with Block	Status Register Data
	Clear Status Register	1	Write	Any Address	0x50			
Program	Program	2	Write	Address of memory location to be programmed	0x40 or 0x10	Write	Address of memory to be programmed	Data to be programmed
	Write to Buffer ⁴	Number of buffer words + 3	Write	Address within Block	0xE8	Write	Address within Block	Number of words to be written to buffer
	Buffered EFP	≥2	Write	Address of memory location to be programmed	0x80	Write	Address within Block	0xD0
Erase	Block Erase	2	Write	Address within Block	0x20	Write	Address within Block	0xD0
Suspend	Erase/Program Suspend	1	Write	Any Address	0xB0			
Resume	Erase/Program Resume	1	Write	Any Address	0xD0			

Table 15. Command Bus Definitions (Sheet 2 of 2)

	Command	Bus Cycles	First Bus Cycle			Second Bus Cycle		
			Type	Addr	Data	Type	Addr	Data
Register Configuration (Burst, Lock, STS and Protection)	Read Configuration Register	2	Write	CD ¹	0x60	Write	CD ¹	0x03
	Lock Block	2	Write	Address within Block	0x60	Write	Address within Block	0x01
	Unlock Block	2	Write	Address within Block	0x60	Write	Address within Block	0xD0
	Lock-Down Block	2	Write	Address within Block	0x60	Write	Address within Block	0x2F
	STS	2	Write	Any Address	0xB8	Write	Any Address	CC ²
	Protection Program	2	Write	PA ⁵	0xC0	Write	PA ⁵	Data to be programmed to the Protection Register
	Lock Protection Program	2	Write	Lock Protection Address for 128-bit	0xC0	Write	Lock Protection Address for 128-bit	0xFFFFD
	Lock 2K OTP Protection	2	Write	Lock Protection Address for 2K-bit	0xC0	Write	LPA1	LPD ³

NOTES:

1. CD = Configuration register data presented on device addresses A[A_{MIN}+15:A_{MIN}]. A[A_{MAX}:A_{MIN}+16] address bits must be cleared. See [Table 16, "Read Configuration Register" on page 40](#) for RCR bit descriptions.
2. CC = STS Configuration code on D[7:0].
3. LPD = Lock Protection Register1 Data. Valid values are between 0xFFFFE and 0x0000.
4. The second cycle of the Write-to-Buffer command is the count of words to load into the buffer, followed by data streaming up to the count value. Then a Confirm command (0xD0) is issued to execute the program operation. Refer to [Figure 25, "Write to Buffer Flowchart" on page 70](#).
5. PA = Valid Protection Register Address.

10.0 Read Modes

The device supports four types of read modes: read array, read identifier, read status or read query. Upon power-up or return from reset, the device defaults to read array mode. To change the device's read mode, the appropriate Read command must be written to the device. (See [Section 9.2, "Device Commands" on page 37.](#)) See [Section 14.0, "Special Modes" on page 56](#) for details regarding read status, read ID, and CFI query modes.

The device supports two types of array read modes: asynchronous page mode and synchronous burst mode. Asynchronous page mode is the default read mode after powered-up, or after a reset. The RCR must be configured to enable Synchronous Burst reads of the flash memory array. (See [Section 10.3, "Read Configuration Register" on page 40.](#))

The Read Array command functions independent of V_{PEN} . The following sections describes read-array mode operations in detail.

10.1 Asynchronous Page-Mode Read

Asynchronous page mode is the default read mode upon power-up or return from reset. However, to perform array reads after any other device operation (e.g., a write operation), the Read Array command must be issued in order to read from the flash memory. Asynchronous page-mode reads are permitted in all blocks, and it is used to access device register information.

Note: Asynchronous page mode reads can only be performed when RCR bit 15 is set (default). (See [Section 10.3, "Read Configuration Register" on page 40.](#))

To perform an asynchronous page-mode read, an address is driven onto $A[A_{MAX}:A_{MIN}]$, and $CE\#$ and $OE\#$ are asserted. $WE\#$ and $RST\#$ must be de-asserted. $ADV\#$ must be held low throughout the read cycle. CLK and $WAIT$ are not used for asynchronous page-mode reads. If only asynchronous reads are to be performed, it is recommended that CLK be tied to a valid V_{IH} level. Array data is driven out on $D[15:0]$ after a minimum delay. (See [Section 7.1, "Read Operations" on page 24.](#))

In asynchronous page mode, one of 16 eight-word groups are "sensed" simultaneously from the flash memory and loaded into an internal page buffer. After the initial access delay, the first word out of the data buffer corresponds to the initial address, $A[A_{MAX}:A_{MIN}]$. Address bits $A[A_{MAX}:A_{MIN} + 3]$ are latched by the device. However, the lower address bits, $A[A_{MIN} + 2:A_{MIN}]$, are not latched.

Address bits $A[A_{MIN} + 2:A_{MIN}]$ determine which word of the eight-word group is output from the data buffer at any given time. Subsequent reads from the device come from the page buffer, and are output on $D[15:0]$ after a minimum delay, as long as address bits $A[A_{MIN} + 2:A_{MIN}]$ are the only address bits that change. Data can be read from the page buffer multiple times, and in any order. If address bits $A[A_{MAX}:A_{MIN} + 3]$ change at any time, or if $CE\#$ is toggled, the device will sense and load a new eight-word group from the flash memory into the page buffer.

By controlling certain signals, such as $CE\#$ and/or $OE\#$, the device can be made to output less than eight-words of data. Asynchronous page-mode read is used to access register information, but only one word is loaded into the page buffer.

10.2 Synchronous Burst-Mode Read

Since asynchronous page mode is the default read mode following a device power-up or reset, the appropriate bits in the RCR must be set before synchronous burst mode reads of the flash memory can occur. See [Section 10.3, “Read Configuration Register” on page 40](#) for details. Immediately after configuring the RCR, it is not necessary to issue the Read Array command (0xFF) before performing a synchronous burst-mode read. However, to perform a synchronous burst-mode read after executing any other device operation (e.g., a write operation), it is necessary to issue the Read Array command before performing a synchronous burst-mode read of the flash memory.

To perform a synchronous burst-mode read, an address is driven onto A[A_{MAX}:A_{MIN}], and CE# and OE# are asserted. WE# and RST# must be de-asserted. ADV# is asserted, then de-asserted to latch the address. Alternatively, ADV# can remain asserted throughout the burst access, in which case, the address is latched on the next valid CLK edge.

In synchronous burst mode, one or two of the 16 eight-word groups are “sensed” simultaneously from the flash memory and loaded into an internal page buffer. After the initial access delay, the first word is output from the data buffer on the next valid CLK edge. Subsequent buffer data is output on valid CLK edges. Synchronous burst-mode reads can only step through the data buffer once, and can only do so in a sequential manner; starting from the address latched at the beginning of the burst cycle (see [Section 7.1, “Read Operations” on page 24](#)).

The device supports 8- or 16- word bursts. However, by controlling certain control signals, such as CE# and/or OE#, the device can output less than 8/16-words of synchronous data. A burst-mode read can be used to access register information. When a burst-mode read is performed on a register, only one word is loaded into the data buffer. In burst mode, the address is latched by either the rising edge of ADV# or the next valid edge of CLK with ADV# low, whichever occurs first.

10.3 Read Configuration Register

The Read Configuration Register (RCR) is used to select the read mode (synchronous or asynchronous), and it defines the synchronous burst characteristics of the device. To modify the RCR settings, write the RCR command to the device (see [Section 9.0, “Bus Operations” on page 35](#)).

RCR contents can be examined by writing the Read Identifier command to the device. See [Section 14.2, “Read Device Identifier” on page 57](#)). The RCR Register is shown in [Table 16](#). The following sections describe each RCR bit in detail.

Table 16. Read Configuration Register (Sheet 1 of 2)

Read Configuration Register (RCR)											Default Value = 0xFFC7				
15	14	13	12	11	10	9	8	7	6	5	4	3	2	1	0
Read Mode	Latency Count				WAIT Polarity	Data Hold	WAIT Delay	Burst Seq	CLK Edge	RES	RES	RES	Burst Length		
RM	LC[3:0]				WP	DH	WD	BS	CE	R	R	R	BL[2:0]		
Bit	Name				Description										
15	Read Mode (RM)				0 = Synchronous burst-mode read 1 = Asynchronous page-mode read (default)										

Table 16. Read Configuration Register (Sheet 2 of 2)

14:11	Latency Count (LC[3:0])	0000 = Code 0. RFU 0001 = Code 1. RFU 0010 = Code 2 0011 = Code 3 0100 = Code 4 0101 = Code 5 0110 = Code 6 0111 = Code 7 1000 = Code 8 1001 = Code 9 1010 = Code 10 1011 - 1111 = Code 11 - Code 15. All these codes are RFU
10	Wait Polarity (WP)	0 = WAIT signal is active low 1 = WAIT signal is active high (default)
9	Data Hold (DH)	0 = Hold data for one clock 1 = Hold data for two clocks (default)
8	Wait Delay (WD)	0 = WAIT de-asserted with valid data 1 = WAIT de-asserted one clock before valid data (default)
7	Burst Sequence (BS)	0 = Reserved 1 = Linear (default)
6	Clock Edge (CE)	0 = falling edge 1 = rising edge (default)
5:3	Reserved (R)	000 - Cannot be changed
2:0	Burst Length (BL[2:0])	001 = RFU 010 = 8-word burst 011 = 16-word burst 111 = RFU (default)

10.3.1 Read Mode

The read mode (RM) bit selects synchronous burst mode or asynchronous page mode operation of the device. When the RM bit is set, asynchronous page mode is selected (default). When RM is cleared, synchronous burst mode is selected.

Synchronous burst mode is used for array reads, whereas asynchronous page mode is used for reading array data, Status Register information, Device ID information, and CFI information. Note that when operating in synchronous burst mode, Status, ID, and CFI information will be driven onto the bus on the next valid clock edge following the initial synchronous access delay, and will remain on the bus for the duration of the access cycle.

10.3.2 Latency Count

The Latency Count bits, LC[3:0], tell the device how many clock cycles must elapse from the rising edge of ADV# (or from the first valid clock edge after ADV# is asserted) until the first data word is to be driven onto D[15:0]. [Table 20 on page 42](#) shows the data output latency for the valid settings of LC[3:0]. See [Table 17 on page 42](#) for latency setting values matched for input clock frequencies.

Figure 20. First-Access Latency Count

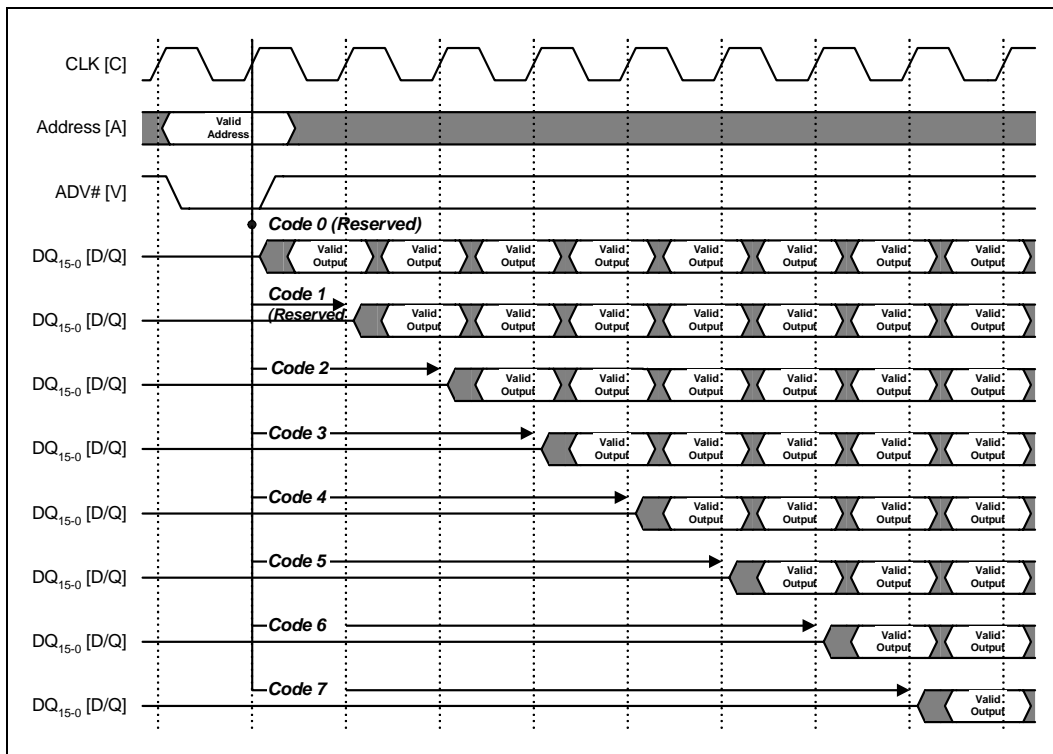
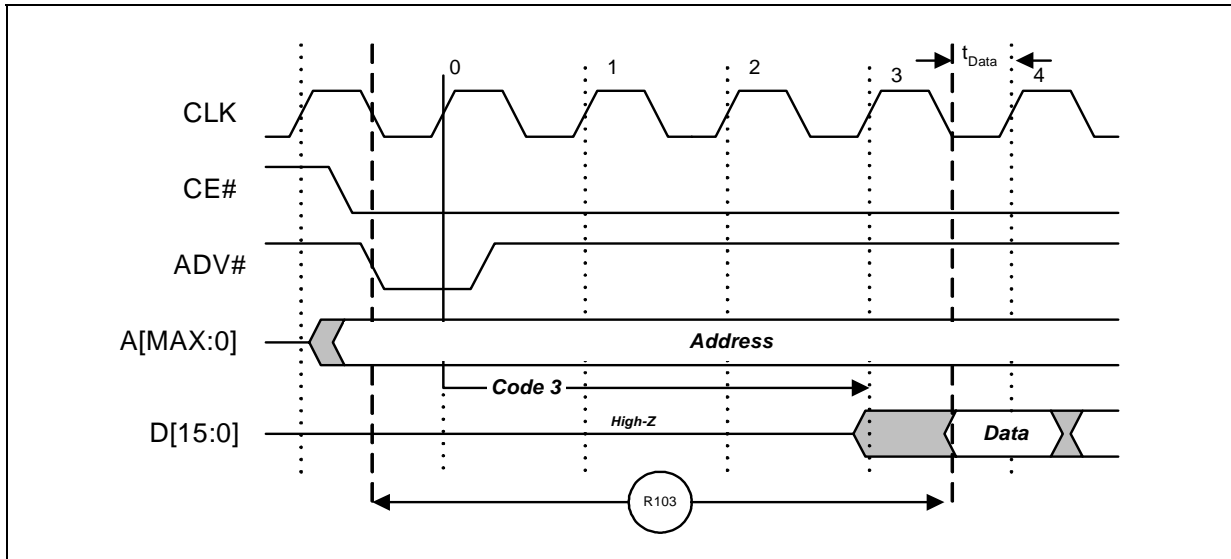


Table 17. Latency Count Table

LC Setting	64 Mb		128 Mb		256 Mb	
	K18	K3	K18	K3	K18	K3
≥ 2	1 to 21 MHz	1 to 20 MHz	1 to 20 MHz	1 to 19 MHz	1 to 19 MHz	1 to 18 MHz
≥ 3	22 to 31 MHz	21 to 30 MHz	21 to 30 MHz	20 to 29 MHz	20 to 28 MHz	19 to 28 MHz
≥ 4	32 to 42 MHz	31 to 41 MHz	31 to 40 MHz	30 to 39 MHz	29 to 38 MHz	29 to 37 MHz
≥ 5	43 to 50 MHz	42 to 51 MHz	41 to 50 MHz	40 to 49 MHz	39 to 47 MHz	38 to 46 MHz
≥ 6	na	51 to 61 MHz	na	50 to 59 MHz	48 to 50 MHz	47 to 56 MHz
≥ 7	na	62 to 66 MHz	na	59 to 66 MHz	na	57 to 66 MHz

Figure 21 shows an example of a LC setting of Code 3.

Figure 21. Example Latency Count Setting



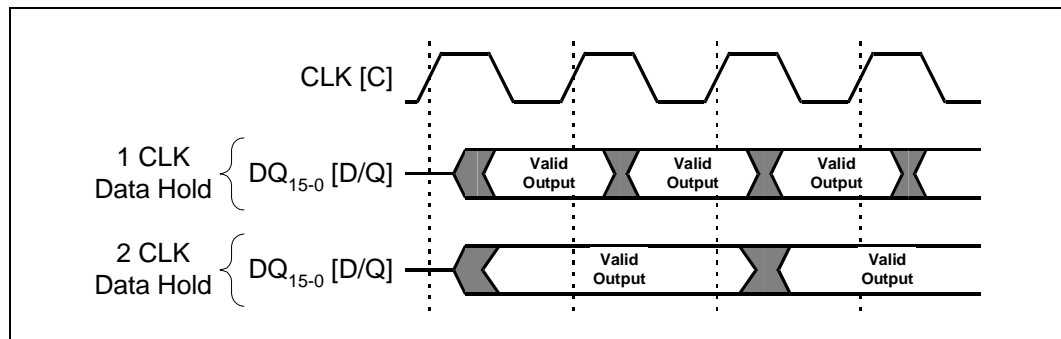
10.3.3 WAIT Polarity

The WAIT Polarity (WP) bit selects the asserted, or true, state of WAIT. When WP is set, WAIT is an active-high signal (default). When WP is cleared, WAIT is an active-low signal.

10.3.4 Data Hold

For burst read operations, the Data Hold (DH) bit determines whether the data output remains valid on D[15:0] for one or two clock cycles. When DH is set, output data is held for two clocks (default). When DH is cleared, output data is held for one clock cycle. (See Figure 22.) The processor's data setup time and the flash memory's clock-to-data output delay should be considered in determining whether to hold output data for one or two clocks.

Figure 22. Data Hold Timing



10.3.5 WAIT Delay

The WAIT Delay (WD) bit controls the WAIT signal's delay behavior during synchronous burst reads. WAIT can be asserted either during, or one clock cycle before, valid data is output on D[15:0]. When WD is set, WAIT is de-asserted one clock before valid data (default). When WD is cleared, WAIT is de-asserted with valid data. The setting of WD is dependent on the system and CPU data sampling requirements.

10.3.6 Burst Sequence

The Burst Sequence (BR) bit selects linear-burst sequence (default). Only linear-burst sequence is supported. Table 18 shows the synchronous burst sequence for all burst lengths.

Table 18. Burst Sequence Word Ordering

Start Addr. (DEC)	Burst Addressing Sequence (DEC)	
	8-Word Burst (BL[2:0] = 010)	16-Word Burst (BL[2:0] = 011)
0	0-1-2-3-4-5-6-7	0-1-2-3-4...14-15
1	1-2-3-4-5-6-7-0	1-2-3-4-5...15-0
2	2-3-4-5-6-7-0-1	2-3-4-5-6...0-1
3	3-4-5-6-7-0-1-2	3-4-5-6-7...1-2
4	4-5-6-7-0-1-2-3	4-5-6-7-8...2-3
5	5-6-7-0-1-2-3-4	5-6-7-8-9...3-4
6	6-7-0-1-2-3-4-5	6-7-8-9-10...4-5
7	7-0-1-2-3-4-5-6	7-8-9-10-11...5-6
⋮	⋮	⋮
14		14-15-0-1-2...12-13
15		15-0-1-2-3...13-14
⋮	⋮	⋮

10.3.7 Clock Edge

The Clock Edge (CE) bit selects either a rising (default) or falling clock edge for CLK. This is the clock edge that is used at the start of a burst cycle to output synchronous data and to assert/de-assert WAIT.

10.3.8 Burst Length

BL[2:0] selects the linear burst length for all synchronous burst reads of the flash memory. The burst length can be configured to be an 8-word or a 16-word burst. Once a burst cycle begins, the device will output synchronous burst data until it reaches the end of the burstable address space.

11.0 Program Modes

The device supports three different programming methods: Word Programming, Write-Buffer Programming, and Buffered Enhanced Factory Programming or Buffered-EFP. Successful programming requires the addressed block to be unlocked. If the block is locked down, WP# must be de-asserted and the block unlocked before attempting to program the array. An attempt to program a locked block will result in the operation aborting, and SR[1] and SR[4] being set, indicating a programming error. The following sections describe device programming in detail.

11.1 Word Programming

Word Programming is performed by executing the Word Program command. Word Programming is a non-buffered operation and programs one word to the flash array based on the initial program address A[A_{MAX}:A_{MIN}]. To determine the status of a word-program operation, poll the status register and analyze the bits. If the flash device is put in standby mode during a program operation, the device will continue to program the word until the operation is complete; then the device will enter standby mode. Refer to [Figure 26, “Word Programming Flowchart” on page 71](#) for a detailed flow on how to implement a word program operation.

During programming, the Write State Machine executes a sequence of internally-timed events that program the desired data bits and verifies that the bits are sufficiently programmed. Programming the flash memory array changes “ones” to “zeros.” Memory array bits that are zeros can be changed to ones only by erasing the block.

When programming has finished, Status Register bit SR4 set indicates a programming failure. If SR3 is set, this indicates that the Write State Machine could not perform the Word Programming operation because V_{PEN} was outside of its acceptable limits. If SR1 is set, the Word Programming operation had attempted to program a locked block, causing the operation to abort.

After examining the status register, it should be cleared using the Clear Status Register command before issuing a new command. Any valid command can follow, after Word Programming has completed.

11.2 Write-Buffer Programming

The device features a 32-word Write Buffer to allow optimum programming performance. For Write-Buffer Programming, data is first written to an on-chip write buffer, then programmed into the flash memory array in buffer-size increments. Optimal performance is realized when programming is buffer-size aligned to the 32-word write-buffer boundary. The write-buffer is directly mapped to the flash array through A[A_{MIN}+4:A_{MIN}]. Unaligned buffered writes will decrease program performance. Buffered writes can improve system programming performance more than 20X over non write-buffer programming.

To perform Write-Buffer Programming, the Write-to-Buffer Setup command, 0xE8, is issued along with the block address (see [Section 9.2, “Device Commands” on page 37](#)). Status Register information is updated, and a read from the block address will return Status Register data showing the write buffer’s availability. *Note: Do not issue the Read Status Register command during this sequence.* SR7 indicates the availability of the write buffer for loading data. If SR7 is set, the write

buffer is available; if not set, the write buffer is not available. To retry, issue the Write-to-Buffer Setup command again, and re-check SR7. When SR7 is set, the write buffer is available. See [Figure 25, “Write to Buffer Flowchart” on page 70](#).

Next, a word count (actual word count - 1) is written to the device at the buffer address. This tells the device how many data words will be written to the write buffer, up to the maximum size of the write buffer. The valid range of values for word count is 0x00 to 0x1F.

On the next write, a device start address is given along with the first data to be written to the flash memory array. Subsequent writes provide additional device addresses and data. All data addresses must lie within the start address plus the word count. Maximum programming performance and lower power are obtained by aligning the starting address at the beginning of a 32 word boundary. A misaligned starting address will result in a doubling of the total program time.

After the last data is written to the write buffer, the Write-to-Buffer Confirm command is issued. The Write State Machine begins to copy the write buffer contents to the flash memory array. If a command other than the Write-to-Buffer Confirm command is written to the device, a command sequence error will occur and Status Register bits SR4, SR5 and SR7 will be set. If an error occurs while writing to the array, the device will stop programming, and Status Register bit SR4 and SR7 will be set, indicating a programming failure.

Additional buffer writes can be initiated by issuing another Write-to-Buffer Setup command and repeating the write-to-buffer sequence.

Anytime SR4 and SR5 are set, the device will not accept Write-to-Buffer commands. If an attempt is made to program past a block boundary using the Write-to-Buffer command, the device will abort the operation. This will generate a command sequence error, and Status Register bits SR4 and SR5 will be set.

If Write-Buffer Programming is attempted while V_{PEN} is below V_{PENLK} , Status Register bits SR3 and SR4 will be set. If any errors are detected that have set Status Register bits, the Status Register should be cleared using the Clear Status Register command.

11.3 Program Suspend

To execute a program suspend, execute the Program Suspend command. A suspend operation halts any in-progress programming operation. The Suspend command can be written to any device address. A Suspend command allows data to be accessed from any memory location other than those suspended.

A program operation can be suspended to perform a device read. A program operation nested within an erase suspend operation can be suspended to read the flash device. Once the program process starts, a suspend operation can only occur at certain points in the program algorithm. Erase suspend operations cannot resume until program operations initiated during the erase suspend are complete. All device read functions are permitted during a suspend operation.

During a suspend, V_{PEN} must remain at a valid program level and WP# must not change. Also, a minimum amount of time is required between issuing a Program or Erase command and then issuing a Suspend command.

11.4 Program Resume

To resume (i.e., continue) a program suspend operation, execute the Program Resume command. The Resume command can be written to any device address. When a program operation is nested within an erase suspend operation and the Program Suspend command is issued, the device will suspend the program operation. When the Resume command is issued, the device will resume and complete the program operation. Once the nested program operation is completed, an additional Resume command is required to complete the block erase operation. The device supports a maximum suspend/resume of two nested routines. See [Figure 27, “Program Suspend/Resume Flowchart” on page 72](#).

11.5 Buffered Enhanced Factory Programming (Buffered-EFP)

Buffered-EFP speeds up MLC flash programming for today’s beat-rate-sensitive manufacturing environments. This enhanced algorithm eliminates traditional elements that drive up overhead in off-board or on-board, off-line or in-line, manual or automated programmer systems. Buffered-EFP is different than non-buffered EFP mode; it incorporates a write buffer to spread MLC program performance across 32 data words. Additionally, verification occurs in the same phase as programming, an inherent requirement of two-bit-per-cell technology to accurately program the correct state.

A single two-cycle command sequence programs an entire block of data. This enhancement eliminates three write cycles per buffer page, two commands and the word count per each set of 32 data words. Host programmer bus cycles fill the device write buffer, followed by a status check of SR.0 to determine when the data from that page has completed programming into sequential flash memory locations. Following the buffer-to-flash programming sequence, the WSM increments internal addressing to automatically select the next 32-word array boundary. This aspect of Buffered-EFP saves programming equipment address-bus setup overhead. In combination, these enhancements allow programming equipment to stream data to the device.

With proper continuity testing, programming equipment can rely on the WSM internal verification to assure the device has programmed properly. This capability eliminates the external post-program verification and its associated overhead. Buffered-EFP consists of three phases: setup, program/verify, and exit. Refer to [Figure 28, “Buffered Enhanced Factory Programming Procedure Flowchart” on page 73](#) for a graphical representation of Buffered-EFP.

11.5.1 Buffered-EFP Requirements and Considerations

Buffered-EFP requirements:

- Ambient temperature: $T_A = 25\text{ °C} \pm 5\text{ °C}$
- V_{CC} within specified operating range
- V_{PEN} driven to V_{PENH}
- Target block unlocked before issuing the Setup and Confirm commands
- WA_0 (first word address in block to be programmed) must be held constant from setup phase through all data streaming in the target block, until transition to the exit phase is desired
- WA_0 must align with the start of an array buffer boundary¹

Buffered-EFP considerations:

- For optimum performance, limit cycling below 100 erase cycles per block²
- Buffered-EFP programs one block at a time, all buffer data must fall within a single block³
- Buffered-EFP cannot be suspended
- Programming to flash can only occur when the buffer is full⁴

¹Buffer boundary in array is determined by $A[A_{MIN}+4:A_{MIN}]$ (00h through 1Fh). Alignment start point is $A[A_{MIN}+4:A_{MIN}]=0$.

²Some degradation in performance may occur if this limit is exceeded, but the internal algorithm will continue to work properly.

³If the internal address counter increments beyond the block's maximum address, addressing will wrap around to the beginning of the block.

⁴If the number of words is less than 32, as in the case of the last page program sequence for a block, remaining locations must be filled with FFFFh. The responsibility to manage this falls within the programming equipment, not the customer data file.

See [Figure 28, “Buffered Enhanced Factory Programming Procedure Flowchart”](#) on page 73, for a detailed flowchart of the Buffered-EFP operation.

11.5.2 Buffered-EFP Setup Phase

After receiving the Buffered-EFP Setup (80h) and Confirm (D0h) command sequence, device SR.7 transitions from a '1' to a '0,' indicating that the WSM is busy with the Buffered-EFP algorithm startup. A delay before checking SR.7 is required to allow the WSM time to perform all of its setups and checks (block lock status and V_{PEN} level). If an error is detected, SR.4 is set and Buffered-EFP operation terminates. If the block was found locked, SR.1 is also set. SR.3 is set if the error occurred due to the V_{PEN} level being incorrect.

11.5.3 Buffered-EFP Program and Verify Phase

After setup completion, the host programming system must check SR.0 to determine “data-stream ready” status. SR.0=0 indicates that the Buffered-EFP program/verify phase is activated and the write buffer is available.

Two basic sequences repeat in this phase: loading the write buffer, followed by buffer data programming to the array. For Buffered-EFP, the count value for buffer loading is always the maximum buffer size of 32 words. During the page loading sequence, data received is stored to sequential buffer locations starting at address 00h. Programming of that page to the flash array starts immediately when the buffer is full.

Warning: The buffer must be completely full for programming to occur. Supplying an address outside the current block's range during a buffer fill sequence will cause the operation to lockup.

Note: If the number of words is less than 32, as in the case of the last page program sequence for a block, remaining locations must be filled with FFFFh. The responsibility to manage this falls within the programming equipment, not the customer data file.

Data words from the write buffer are directed to sequential memory locations in the array, programming takes up where the last page sequence left off. The host programming system must poll SR.0 to determine when the page program sequence completes. SR.0=0 indicates that all

buffer data has been transferred to the flash array, SR.0=1 indicates that the WSM is still busy. The host system may check full status for errors at any time, but it is only necessary on a block basis, after Buffered-EFP exit.

The host programming system continues the Buffered-EFP algorithm by providing the next set of data words to the buffer. Alternatively, it can terminate this phase by changing the block address. The program/verify phase concludes when the interfacing programmer writes to a different block address; data supplied must be FFFFh. Upon program/verify phase completion, the device enters the Buffered-EFP exit phase.

11.5.4 Buffered-EFP Exit Phase

SR.7=1 indicates that the device has returned to normal operating conditions. A full status check should be performed at this time to ensure the entire block programmed successfully. After Buffered-EFP exit, any valid CUI command can be issued. The Buffered-EFP SR.7 and SR.0 Truth table is shown in [Table 19](#).

Table 19. Buffered-EFP SR.7 and SR.0 Truth table

SR.7	SR.0	Condition
0	0	Device is BUSY, Buffer is AVAILABLE.
0	1	Device is BUSY, Buffer is NOT AVAILABLE.
1	0	Device is READY, Buffer is AVAILABLE.
1	1	Invalid state.

12.0 Erase Mode

Flash erasing is performed on a block basis; therefore, only one block can be erased at a time. When a block is erased, all bits within that block will read as a logic level one. To determine the status of a Block Erase, poll the status register and analyze the bits. The following section describes Block Erase operations in detail.

12.1 Block Erase

Block Erase operations are initiated by writing the Block Erase command to the address of the block to be erased (refer to [Section 9.2, “Device Commands” on page 37](#)). This is followed by the Block Erase Confirm command written to the address of the block to be erased. If the device is placed in standby (CE# de-asserted) during an erase operation, the device will continue to erase the block until the erase operation is completed before entering standby. V_{PEN} must be above V_{PENLK} and the block must be unlocked (see [Figure 29, “Block Erase Flowchart” on page 74](#)). Also, V_{PEN} must remain at a valid level, and WP# must remain unchanged while in erase suspend.

During a Block Erase, the Write State Machine executes a sequence of internally-timed events that conditions, erases, and verifies all bits within the block are erased. Erasing the flash memory changes array data from “zeros” to “ones.”

Status Register bit SR7 indicates Block Erase status while the sequence executes. If Status Register bit SR5 is set after erase completion, this indicates an erase failure. If SR3 is set, this indicates that the Write State Machine could not perform the erase operation because V_{PEN} was outside of its acceptable limits. If SR1 is set, the erase operation attempted to erase a locked block, causing the operation to abort. CE# or OE# must be toggled to update Status Register contents.

After examining the status register, it should be cleared using the Clear Status Register command before issuing a new command. Any valid command can follow, once the block erase operation has completed.

12.2 Erase Suspend

Issuing the Erase Suspend command while erasing suspends the block erase operation. This allows data to be accessed from memory locations other than the one being erased. The Erase Suspend command can be issued to any device address within the block. A block erase operation can be suspended to perform either a word program or a read operation within any block, except the block that is in an erase suspend state (see [Figure 30, “Erase Suspend/Resume Flowchart” on page 75](#)).

When a block erase operation is executing, issuing the Erase Suspend command requests the Write State Machine to suspend the erase algorithm at predetermined points. An erase operation cannot be nested within another erase suspend operation. Block erase is suspended when Status Register bits SR[7,6] are set. Suspend latency is specified in [Section 7.3, “Block Erase and Program Operation Performance” on page 31](#).

Block erase cannot resume until program operations initiated during erase suspend complete. Read Array, Read Status Register, Read Identifier, CFI Query, and Program Resume are valid commands during Erase Suspend. Additionally, Clear Status Register, Program, Program Suspend, Erase Resume, Block Lock, Block Unlock, and Block Lock-Down are valid commands during Erase Suspend.

12.3 Erase Resume

To resume (i.e., continue) an erase suspend operation, execute the Erase Resume command. The Resume command can be written to any device address. When a program operation is nested within an erase suspend operation and the Program Suspend command is issued, the device will suspend the program operation. When the Resume command is issued, the device will resume the program operations first. Once the nested program operation is completed, an additional Resume command is required to complete the block erase operation. The device supports a maximum suspend/resume of two nested routines. See [Figure 29, “Block Erase Flowchart” on page 74](#).

13.0 Security Modes

This device offers both hardware and software security features. Block lock operations, the Protection Registers, and VPEN enable the user to implement various levels of data protection. The following section describes security features in detail.

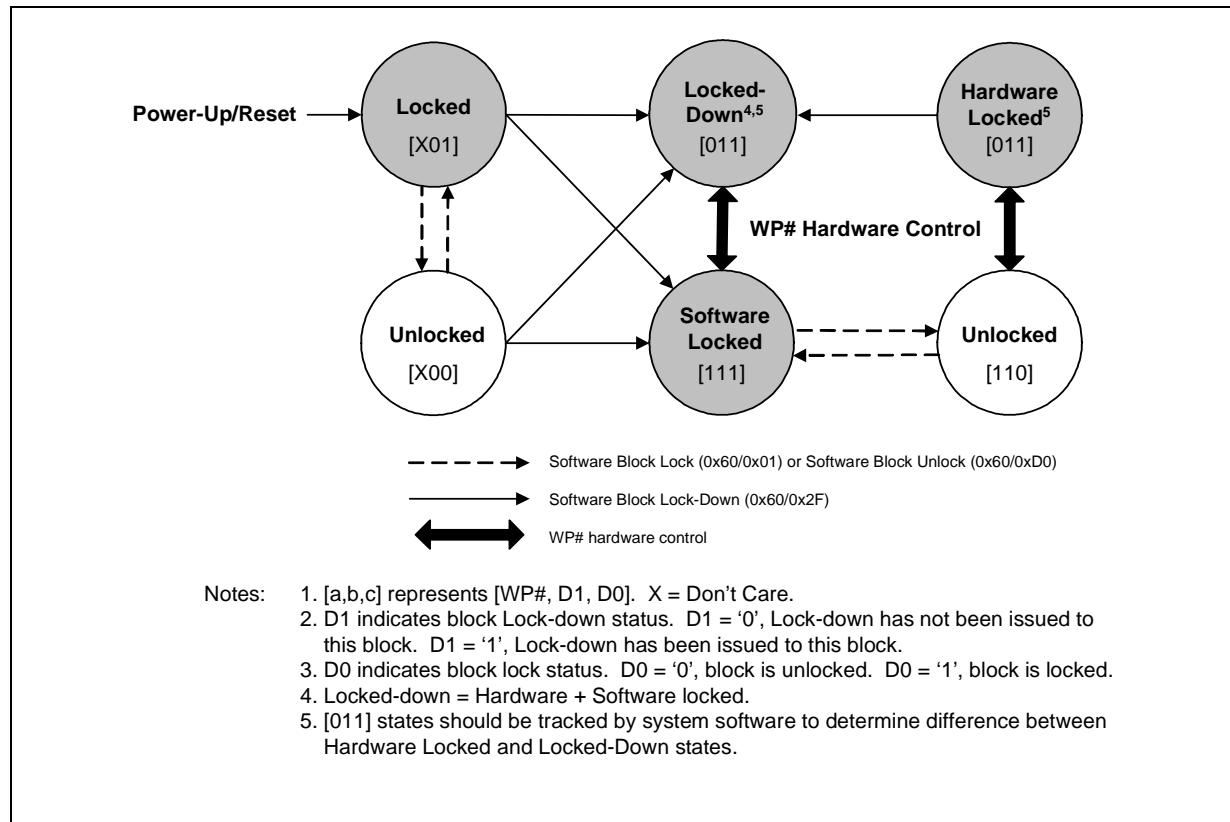
13.1 Block Locking Operations

Individual instant block locking is used to protect user code and/or data within the flash memory array. All blocks power up locked to protect array data from being altered during power transitions. Any block can be locked or unlocked without latency. Locked blocks cannot be programmed or erased; they can only be read.

Software-controlled security is implemented with the Block Lock and Block Unlock commands. Hardware-controlled security can be implemented with the Block Lock-Down command and WP#.

Refer to [Figure 23](#) for a state diagram of the flash security features. Also see [Figure 32](#), “Block Lock Operations Flowchart” on page 77.

Figure 23. Block Locking State Diagram



13.1.1 Block Lock

All blocks default to the locked state after initial power-up or reset. An unlocked block can be locked by issuing the Block Lock command sequence. This sets the block lock status bit and fully protects the block from program or erase. Attempted program or erase operations to a locked block will return an error in SR1.

13.1.2 Block Unlock

A locked block can be unlocked by issuing the Block Unlock command. All unlocked blocks return to the locked state when the device is reset or powered-down. Unlocked blocks may be programmed or erased.

13.1.3 Block Lock-Down

The Lock-Down Block command adds an additional level of security to the device. Issuing the Lock-Down Block command sets the lock-down status bit and locks the block. The Lock-Down Block command can be used if the block's current state is either locked or unlocked. Once this bit is set, WP# is enabled as a hardware lock control for that particular block. If a block is locked-down and WP# is de-asserted, the user may issue the Unlock Block command to allow program or erase operations on that block.

Note: Only device reset or power-down can clear the lock-down status bit.

13.1.4 Block Lock During Erase Suspend

Blocks may be locked, unlocked, or locked down during an erase suspend operation. First, write the Erase Suspend command to the device. After checking SR7 and SR6 to determine that the erase operation has suspended, write the desired lock command sequence to a block. The lock status bit(s) will change immediately. If the block being locked or locked-down is the same block that is suspended, the lock status bit(s) will still change immediately, but the erase operation will complete when resumed. After completing lock, unlock, read, or program operations, resume the erase operation with the Erase Resume command.

Note: A Block Lock Setup command followed by any command other than Block Lock, Block Unlock, or Block Lock-Down will produce a command sequence error and set Status Register bits SR4 and SR5. If this error occurs while an erase is suspended, SR4 and SR5 will remain set after the erase operation is resumed unless the Status Register is cleared first using the Clear Status Register command. Otherwise, possible erase errors may become masked by the command sequence error.

Locking operations cannot occur during *program* suspend. [Appendix A, "Write State Machine \(WSM\)" on page 59](#) shows valid commands during erase suspend.

13.1.5 WP# Lock-Down Control

If the lock-down status bit is set for a particular block, the WP# signal is then enabled as a master lock/unlock override for that particular block. When WP# is asserted, all blocks that have the lock-down status bit set are automatically put into the lock-down state and cannot be unlocked with the Unlock Block command.

Once WP# is de-asserted, the block reverts back to a locked state; only then can it be unlocked via software.

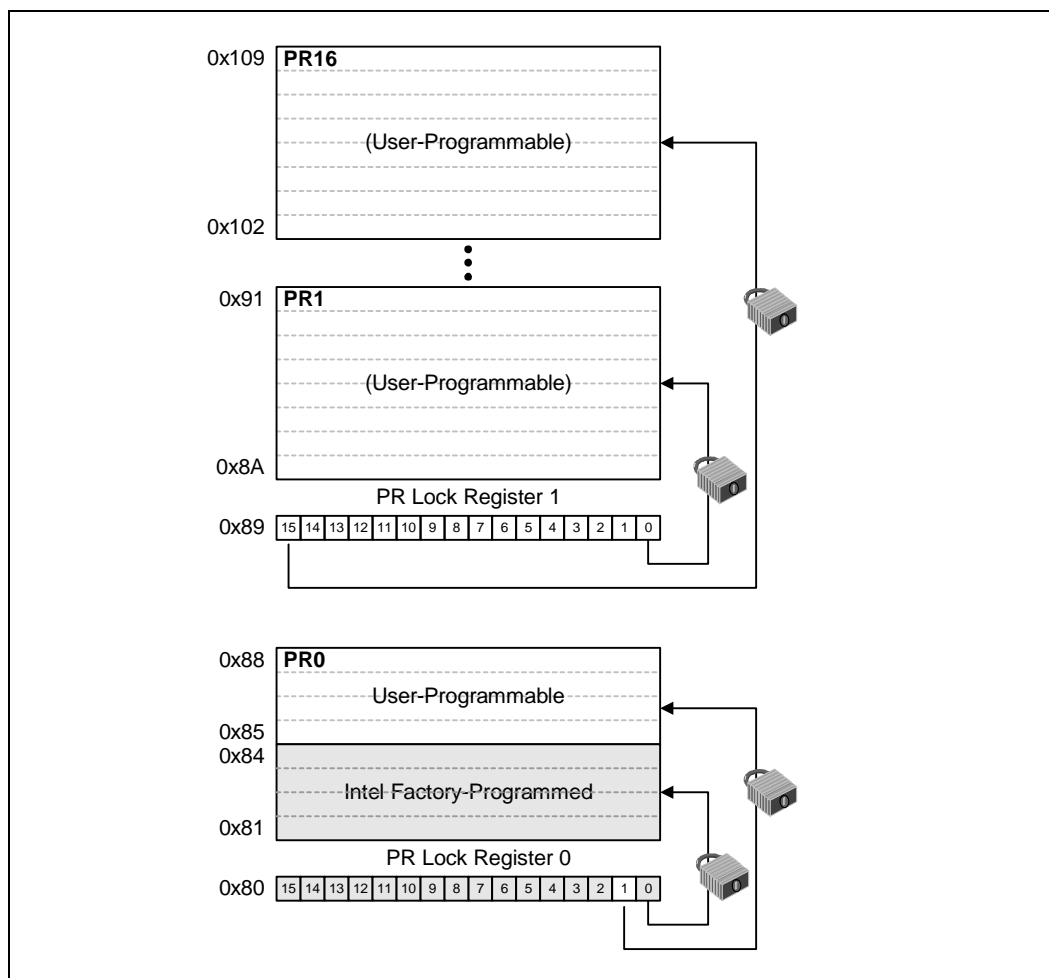
13.2 Protection Registers

The device includes 17 128-bit Protection Registers, PR16 through PR0, which can be used to increase system security or to provide identification capabilities.

PR0[63:0] are permanently programmed by Intel with a unique number for each flash device. PR0[127:64] and PR1 through PR16 are one-time programmable (OTP) and available for the customer to program. Once programmed, the user-programmable registers can be locked to prevent further programming.

Note: User-programmable bits are OTP and may be programmed individually. However, once the protection register is locked, the entire user segment is locked and no more user bits may be programmed.

Figure 24. Protection Register Memory Map



13.2.1 Reading the Protection Registers

To read Protection Register data, issue the Read Identifier command along with the address corresponding to the desired word of register data. (See [Figure 24 on page 54](#).) Protection Register data is read 16 bits at a time.

13.2.2 Programming the Protection Registers

To program a Protection Register, issue the Protection Program command, plus a desired Protection Register offset. See [Figure 24 on page 54](#) for appropriate address offsets of the Protection Register. Only one word may be programmed to the user segment at a time. Issuing the Protection Program command outside the register's address space results in a status register error (SR4=1).

13.2.3 Locking the Protection Registers

To lock a Protection Register, program the corresponding bit in the PR Lock Register by issuing the Program PR Lock Register command followed by the desired PR Lock Register data.

Bit 0 of PR Lock Register 0 is already programmed at the Intel factory and locks PR0[63:0]. Bit 1 of PR Lock Register 0 can be programmed by the user to lock the user-programmable portion of Protection Register 0, namely PR0[128:64]. The rest of the bits in PR Lock Register 0 are not used.

PR Lock Register 1 controls the locking of the remaining 128-bit Protection Registers. Each of the 16 bits of PR Lock Register 1 corresponds to one of the 16 128-bit Protection Registers. For example, to lock PR6, program bit 5 in PR Lock Register 1.

After PR Lock Register bit 1 is programmed (locked), the user segment of the Protection Register cannot be changed. Protection Program commands written to a locked section result in a status register error (SR[5:4]=0b11).

13.3 Array Protection

The V_{PEN} signal is a hardware mechanism to prohibit array alteration. When the V_{PEN} voltage is below the V_{PENLK} voltage, array contents cannot be altered. To ensure a proper erase or program operation, V_{PEN} must be set to a valid voltage level. To determine the status of an erase or program operation, poll the status register and analyze the bits.

14.0 Special Modes

This section describes in details how to read the status, ID and CFI registers. This sections also details how to configure the STS signal.

14.1 Read Status Register

The status of the device can be determined by reading the Status Register. To read the Status Register, issue the Read Status Register command. Status Register data is automatically made available following a Word Program, Block Erase, or Block Lock command sequence. Subsequent reads from the device after any of these command sequences will output that the device's status until another valid command is written to the device (e.g. Read Array).

The Status Register is read using single asynchronous- and single synchronous-reads only; page- or burst-mode reads cannot be used to read the Status Register. Status Register data is output on D[7:0], while 0x00 is output on D[15:8]. The falling edge of OE# or CE# (which ever occurs first) updates and latches the Status Register contents. The Ready bit (SR7) provides overall status of the device. Status register bits SR[6:1] present status and error information about the Program, Erase, Suspend, V_{PEN}, and Block-Locked operation.

Care should be taken to avoid Status Register ambiguity when issuing valid 2-cycle commands during Erase Suspend. If a command sequence error occurs during an erase-suspend state, the Status Register will contain the command sequence error status (SR[7,5:4] set). When the erase operation resumes and finishes, possible errors during the erase operation cannot be detected via the Status Register because it will contain the previous error status. To avoid this situation, always clear the Status Register prior to resuming erase operations.

Table 20. Status Register Description (Sheet 1 of 2)

Status Register (SR)				Default Value =0x80			
Ready	Erase Suspend	Erase Error	Program Error	VPEN	Program Suspend	Block-Locked Error	Buffered-EFP Status
RDY	ES	EE	PE	VE	PS	LE	PS
7	6	5	4	3	2	1	0
Bit	Name		Description				
7	Ready (RDY)		0 = Device is busy; program or erase cycle in progress; SR[0] valid. 1 = Device is ready; SR[6:1] are valid.				
6	Erase Suspend (ES)		0 = Erase suspend not in effect. 1 = Erase suspend in effect.				
5	Erase Error (EE)		0 = Erase successful. 1 = Erase fail or Program Sequence Error when set with SR[7,4].				
4	Program Error (PE)		0 = Program successful. 1 = Program fail or Program Sequence Error when set with SR[7,5]				
3	V _{PEN} Error (VE)		0 = V _{PEN} within acceptable limits during program or erase operation. 1 = V _{PEN} < V _{PEN} LNK during program or erase operation.				

Table 20. Status Register Description (Sheet 2 of 2)

Status Register (SR)		Default Value =0x80
2	Program Suspend	0 = Program suspend not in effect. 1 = Program suspend in effect.
1	Block-Locked Error (LE)	0 = Block not locked during program or erase. 1 = Block locked during program or erase; operation aborted.
0	Buffered-EFP Status (PS)	After Buffered-EFP data is loaded into the buffer: 0 = Buffered-EFP complete. 1 = Buffered-EFP in progress.

14.1.1 Clear Status Register

The Clear Status Register command clears the status register and functions independent of V_{PEN} . The Write State Machine sets and clears status bits (SR[7:6,2,0]), but it only sets error bits (SR[5:4,3,1]). The Status Register should be cleared before starting a command sequence to avoid any ambiguity. A device reset also clears the Status Register.

14.2 Read Device Identifier

The Read Device Identifier command instructs the device to output Manufacturer/ Device Identifier codes, block-lock status, Protection Register data, and Configuration Register data when read. (See [Section 9.2, “Device Commands” on page 37](#) for details on issuing the Read Device Identifier command.)

Table 21. Device Identifier Codes

Item	Address	Data ⁽¹⁾
Manufacturer Code	0x0	0x89
K3 64 Mb Device Code	0x1	0x8801
K3 128 Mb Device Code	0x1	0x8802
K3 256 Mb Device Code	0x1	0x8803
K18 64 Mb Device Code	0x1	0x8805
K18 128 Mb Device Code	0x1	0x8806
K18 256 Mb Device Code	0x1	0x8807
Block is Unlocked	Block Address + 0x2	DQ ₀ = 0
Block is Locked		DQ ₀ = 1
Block is not Locked-Down		DQ ₁ = 0
Block is Locked-Down		DQ ₁ = 1
Configuration Register	0x5	Configuration Register Content
Protection Register Lock	0x80	Protection Register Lock
2K-OTP Lock	0x89	OTP Lock
Protection Register	0x81 - 0x88	Protection Register Content
2K OTP Space	0x8A - 0x109	OTP Content

NOTE: Data is always available on D[7:0]. D[15:8] is 0x00.

14.3 Read Query/CFI

The query register contains an assortment of flash product information such as block size, density, allowable command sets, electrical specifications and other product information. The data contained in this register conforms to the Common Flash Interface (CFI) protocol. To obtain any information from the query register, execute the Read Query Register command. See [Section 9.2, “Device Commands” on page 37](#) for details on issuing the CFI Query command. Refer to [Appendix B, “Common Flash Interface” on page 64](#) for a detailed explanation of the CFI register. Information contained in this register can only be accessed by executing a single-word read.

14.4 STS Configuration (Easy BGA package ONLY)

To configure the STS signal, execute the Configuration command. The STS signal can be configured for level or pulse mode. Once configured to a particular mode, it remains in that mode until the device is powered down, reset or another Configuration command is issued to change the mode. After power-up or reset, the default configuration is level mode. Level mode works similar to a Ready/Busy signal (RY/BY#), indicating the status of the Write State Machine (WSM) during a program or erase operation. The STS Configuration command may only be given when the device is not busy or suspended. The possible STS configurations and usage are described in [Table 22](#).

Table 22. STS Configuration Coding Definitions

DQ7	DQ6	DQ5	DQ4	DQ3	DQ2	DQ1	DQ0
Reserved						Pulse on Program Complete (1)	Pulse on Erase Complete (1)
DQ ₁ _DQ ₀ = STS Configuration Codes				Notes			
00 = default, level mode; device ready indication				Used to control HOLD to a memory controller to prevent accessing a flash memory subsystem while any flash device's WSM is busy.			
01 = pulse on Erase Complete				Used to generate a system interrupt pulse when any flash device in an array has completed a block erase. Helpful for reformatting blocks after file system free space reclamation or “cleanup.”			
10 = pulse on Program Complete				Used to generate a system interrupt pulse when any flash device in an array has completed a program operation. Provides highest performance for servicing continuous buffer write operations.			
11 = pulse on Erase or Program Complete				Used to generate system interrupts to trigger servicing of flash arrays when either erase or program operations are completed, when a common interrupt service routine is desired.			

NOTES:

1. When configured in one of the pulse modes, STS pulses low with a typical pulse width of 250 ns.
2. An invalid configuration code will result in both status register bits SR.4 and SR.5 being set.

Appendix A Write State Machine (WSM)

A.1 Nomenclature

Table 23. Arrangement Of Next State Table Pages

	Next States	
Current States	Part A / page 1	Part B / page 1
	Part A / page 2	Part B / Page 2

Note: Numbered notes referenced in superscript can be found at the end of the last table.

Table 24. Next State Table Part A

Current State	SR7	SR0	Data When Read	Command Input and Next State								
				Read Array 0xFF	Program Setup 0x10/0x40	Write to Buffer Setup ^{2,3} 0xE8	BEFP Setup ¹ 0x30	Erase Setup 0x20	Erase/BEFP/Unlock/Confirm ⁷ 0xD0	Program/Erase Confirm ⁷ 0xD0	Program/Erase Suspend ⁵ 0xB0	
Read Array	1	0	Array	Read Array	Program Setup	Write to Buffer Setup	BEFP Setup	Erase Setup	Read Array		Read Status	
Read Status	1	0	Status	Read Array	Program Setup	Write to Buffer Setup	BEFP Setup	Erase Setup	Read Array		Read Status	
Read Config	1	0	Config	Read Array	Program Setup	Write to Buffer Setup	BEFP Setup	Erase Setup	Read Array		Read Status	
Read Query	1	0	CFI	Read Array	Program Setup	Write to Buffer Setup	BEFP Setup	Erase Setup	Read Array		Read Status	
Lock Setup ⁵	1	0	Status	Botch (command seq. error) if second cycle is anything other than 0xD0, 0x01, 0x2F, or 0x03								
Lock Setup Erase Susp ⁶	1	0	Status	Botch Erase Susp.(command seq. error) if second cycle is anything other than 0xD0, 0x01, 0x2F, or 0x03								
Botch (command seq. error) ⁹	1	0	Status	Read Array	Program Setup	Botch	BEFP Setup	Erase Setup	Read Array		Read Status	
Botch Erase Susp.(command seq. error) ⁹	1	0	Status	Read Array Ers. Susp.	Program Setup Ers. Susp.	Botch Erase. Susp.	Read Status Ers. Susp.	Read Array Ers. Susp.	Read Array Ers.Susp.	Erase	Read Status Ers. Susp.	
Botch Prog. Susp.(command seq. error) ⁹	1	0	Status	Read Array Prog. Susp.	Read Array Prog. Susp.	Botch Prog. Susp.	Read Array Prog. Susp.		Read Array Prog. Susp.	Program (busy)	Read Status Prog. Susp.	
Botch Both Susp. ⁸	1	0	Status	Read Array Both Susp.	Read Array Both Susp.	Botch Both Susp.	Read Array Both Susp.		Read Array Both Susp.	Program (busy) Ers. Susp.	Read Status Both Susp.	
OTP/Prot. Prog. Setup	1	0	Status	OTP/Protection Register Program								
OTP/Prot Prog. (busy)	0	Z	Status	OTP/Protection Register Program (busy)								
OTP.Prot Prog. (done)	1	0	Status	Read Array	Program Setup	Write to Buffer Setup	BEFP Setup	Erase Setup	Read Array		Read Status	
Prog. Setup	1	0	Status	Program (busy)								
Prog. Setup Ers. Susp.	1	0	Status	Program (busy) Ers. Susp.								
Program (busy)	0	Z	Status	Program (busy)								Read Status Prog. Susp.
Program (busy) Ers. Susp.	0	Z	Status	Program (busy) Ers. Susp.								Read Status Both Susp.
Read Status Prog. Susp.	1	0	Status	Read Array Prog. Susp.	Read Array Prog. Susp.				Read Array Prog. Susp.	Program (busy)	Read Status Prog. Susp.	
Read Array Prog. Susp.	1	0	Array	Read Array Prog. Susp.	Read Array Prog. Susp.				Read Array Prog. Susp.	Program (busy)	Read Status Prog. Susp.	
Read Config Prog. Susp.	1	0	Config	Read Array Prog. Susp.	Read Array Prog. Susp.				Read Array Prog. Susp.	Program (busy)	Read Status Prog. Susp.	
Read Query Prog. Susp.	1	0	CFI	Read Array Prog. Susp.	Read Array Prog. Susp.				Read Array Prog. Susp.	Program (busy)	Read Status Prog. Susp.	
Program (done)	1	0	Status	Read Array	Program Setup	Write to Buffer Setup	BEFP Setup	Erase Setup	Read Array		Read Status	
Read Status Both Susp. ⁸	1	0	Status	Read Array Both Susp.						Program (busy) Ers. Susp.	Read Status Both Susp.	
Read Array Both Susp. ⁸	1	0	Array	Read Array Both Susp.						Program (busy) Ers. Susp.	Read Status Both Susp.	
Read Config Both Susp. ⁸	1	0	Config	Read Array Both Susp.						Program (busy) Ers. Susp.	Read Status Both Susp.	
Read Query Both Susp. ⁸	1	0	CFI	Read Array Both Susp.						Program (busy) Ers. Susp.	Read Status Both Susp.	
BEFP Setup	1	0	Status	Botch (command seq. error)					BEFP Setup-time	Botch (command seq. error)		
BEFP Setup-time	0	1	Status	If Time-out > 5 us, go to BEFP Load; If Time-out < 5 us, stay in BEFP Setup-time								
BEFP Load	0	0	Status	Initialize buffer load count to 31; if buffer count=0, then go to BEFP (busy); For buffer count>0 and same block addr. stay in BEFP Load; if block addr. changed, go to BEFP exit								

Table 24. Next State Table Part A

Current State	SR7	SR0	Data When Read	Command Input and Next State								
				Read Array 0xFF	Program Setup 0x10/0x40	Write to Buffer Setup ^{2,3} 0xE8	BEFP Setup ¹ 0x30	Erase Setup 0x20	Erase/BEFP/Unlock Confirm ⁷ 0xD0	Program/Erase Confirm ⁷ 0xD0	Program/Erase Suspend ⁵ 0xB0	
BEFP (busy)	0	1	Status	To exit, change block addr; to continue proceed to BEFP after SR0=0.								
BEFP Exit (Busy)	0	1	Status	Internally timed; Go to BEFP Exit after internal timeout; Transition indicated by SR0=0								
BEFP Exit	1	0	Status	Read Array	Program Setup	Write to Buffer Setup	BEFP Setup	Erase Setup	Read Array		Read Status	
Write to Buffer setup	1	0	Status	Repeat command until SR7=1. Next cycle will be interpreted as Count Load.								
Count Load	1	0	Status	Word count load (Actual number of words-1). Lowest five bits will be assumed as the count. Device assumes next cycles will be Data Load.								
Data Load	1	0	Status	Data load; To quit or abort, change the block address during a write. The UI will botch on a block change. Repeat Data Load until Word Count is reached, next command must be Write to Buffer Confirm								
Write to Buffer Confirm	1	0	Status	Botch (command seq. error)				Program (busy)		Botch (command seq. error)		
Write to Buffer setup Ers. Susp.	1	0	Status	Repeat command until SR7=1. Next cycle will be interpreted as Count Load Ers. Susp..								
Count Load Ers. Susp.	1	0	Status	Word count load (Actual number of words-1). Lowest five bits will be assumed as the count. Device assumes next cycles will be Data Load Ers. Susp..								
Data Load Ers. Susp.	1	0	Status	Data load; To quit or abort, change the block address during a write. The UI will botch on a block change. Repeat Data Load until Word Count is reached, next command must be Write to Buffer Confirm Ers. Susp.								
Write to Buffer confirm Ers. Susp.	1	0	Status	Botch Ers. Susp.(command seq. error)				Program (busy) Ers. Susp.		Botch Ers. Susp.(command seq. error)		
Erase Setup	1	0	Status	Botch (command seq. error)				Erase (busy)		Botch (command seq. error)		
Erase (busy)	0	Z	Status	Erase (busy)								
Read Status Ers. Susp.	1	0	Status	Read Array Ers. Susp.	Program Setup Ers. Susp.	Write to Buffer Setup Ers. Susp.	Read Status Ers. Susp.	Read Array Ers. Susp.	Read Array Ers. Susp.	Erase (busy)	Read Status Ers. Susp.	
Read Array Ers. Susp.	1	0	Array	Read Array Ers. Susp.	Program Setup Ers. Susp.	Write to Buffer Setup Ers. Susp.	Read Array Ers. Susp.	Read Array Ers. Susp.	Read Array Ers. Susp.	Erase (busy)	Read Status Ers. Susp.	
Read Config Ers. Susp.	1	0	Config	Read Array Ers. Susp.	Program Setup Ers. Susp.	Write to Buffer Setup Ers. Susp.	Read Array Ers. Susp.	Read Array Ers. Susp.	Read Array Ers. Susp.	Erase (busy)	Read Status Ers. Susp.	
Read Query Ers. Susp.	1	0	CFI	Read Array Ers. Susp.	Program Setup Ers. Susp.	Write to Buffer Setup Ers. Susp.	Read Array Ers. Susp.	Read Array Ers. Susp.	Read Array Ers. Susp.	Erase (busy)	Read Status Ers. Susp.	
Erase (done)	1	0	Status	Read Array	Program Setup	Write to Buffer Setup	BEFP Setup	Erase Setup	Read Array		Read Status	
STS Reconfig Setup	1	0	Status	If second cycle is 0x00 or 0x01 or 0x02 or 0x03, then reconfigure the STS functionality and go to Read Status; If not Botch.								
STS Reconfig Setup Ers. Susp.	1	0	Status	If second cycle is 0x00 or 0x01 or 0x02 or 0x03, then reconfigure the STS functionality and go to Read Status Ers. Susp; If not Botch Ers. Susp.								
STS Reconfig Setup Prog. Susp.	1	0	Status	If second cycle is 0x00 or 0x01 or 0x02 or 0x03, then reconfigure the STS functionality and go to Read Status Prog.Susp; If not Botch Prog. Susp.								
STS Reconfig Setup Both Susp.	1	0	Status	If second cycle is 0x00 or 0x01 or 0x02 or 0x03, then reconfigure the STS functionality and go to Read Status Both Susp; If not Botch Both Susp.								

Table 25. Next State Table Part B

Current State	SR7	SR0	Data When Read	Command Input and Next State								
				Read Status 0x70	Clear Status ⁴ 0x50	Read Config 0x90	STS Reconfig 0xB8	Read Query 0x98	Lock Setup 0x60	OTP/Prot Program Setup 0xC0	Illegal Commands	
Read Array	1	0	Array	Read Status	Read Array	Read Config	STS Reconfig Setup	Read Query	Lock Setup	OTP/Prot Prog. Setup	Read Array	
Read Status	1	0	Status	Read Status	Read Array	Read Config	STS Reconfig Setup	Read Query	Lock Setup	OTP/Prot Prog. Setup	Read Array	
Read Config	1	0	Config	Read Status	Read Array	Read Config	STS Reconfig Setup	Read Query	Lock Setup	OTP/Prot Prog. Setup	Read Array	
Read Query	1	0	CFI	Read Status	Read Array	Read Config	STS Reconfig Setup	Read Query	Lock Setup	OTP/Prot Prog. Setup	Read Array	
Lock Setup ⁵	1	0	Status	Botch(command seq.error) if second cycle is anything other than 0xD0, 0x01, 0x2F, or 0x03								
Lock Setup Erase Susp ⁶	1	0	Status	Botch Erase Susp.(command seq. error) if second cycle is anything other than 0xD0, 0x01, 0x2F, or 0x03								
Botch (command seq. error) ⁹	1	0	Status	Read Status	Read Array	Read Config	STS Reconfig Setup	Read Query	Lock Setup	OTP/Prot Prog. Setup	Read Array	
Botch Erase Susp.(command seq. error) ⁹	1	0	Status	Read Status Ers. Susp.	Read Array Ers. Susp.	Read Config Ers. Susp.	STS Reconfig Setup Ers. Susp.	Read Query Ers. Susp.	Lock Setup Ers. Susp.	Read Array Ers. Susp.	Read Array	
Botch Prog. Susp.(command seq. error) ⁹	1	0	Status	Read Status Prog. Susp.	Read Array Prog. Susp.	Read Config Prog. Susp.	STS Reconfig Setup Prog. Susp.	Read Query Prog. Susp.	Read Array Prog. Susp.		Read Array Prog. Susp.	
Botch Both Susp. ⁸	1	0	Status	Read Status Both Susp.	Read Array Both Susp.	Read Config Both Susp.	STS Reconfig Setup Both Susp.	Read Query Both Susp.	Read Array Both Susp.		Read Array Both Susp.	
OTP/Prot. Prog. Setup	1	0	Status	OTP/Protection Register Program			OTP/Prot Register Program					
OTP/Prot Prog. (busy)	0	Z	Status	OTP/Protection Register Program (busy)			OTP/Prot Register Program (busy)					
OTP.Prot Prog. (done)	1	0	Status	Read Status	Read Array	Read Config	STS Reconfig Setup	Read Query	Lock Setup	OTP/Prot Prog. Setup	Read Array	
Prog. Setup	1	0	Status	Program (busy)								
Prog. Setup Ers. Susp.	1	0	Status	Program (busy) Ers. Susp.								
Program (busy)	0	Z	Status	Program (busy)								
Program (busy) Ers. Susp.	0	Z	Status	Program (busy) Ers. Susp.								
Read Status Prog. Susp.	1	0	Status	Read Status Prog. Susp.	Read Array Prog. Susp.	Read Config Prog. Susp.	STS Reconfig Setup Prog. Susp.	Read Query Prog. Susp.	Read Array Prog. Susp.		Read Array Prog. Susp.	
Read Array Prog. Susp.	1	0	Array	Read Status Prog. Susp.	Read Array Prog. Susp.	Read Config Prog. Susp.	STS Reconfig Setup Prog. Susp.	Read Query Prog. Susp.	Read Array Prog. Susp.		Read Array Prog. Susp.	
Read Config Prog. Susp.	1	0	Config	Read Status Prog. Susp.	Read Array Prog. Susp.	Read Config Prog. Susp.	STS Reconfig Setup Prog. Susp.	Read Query Prog. Susp.	Read Array Prog. Susp.		Read Array Prog. Susp.	
Read Query Prog. Susp.	1	0	CFI	Read Status Prog. Susp.	Read Array Prog. Susp.	Read Config Prog. Susp.	STS Reconfig Setup Prog. Susp.	Read Query Prog. Susp.	Read Array Prog. Susp.		Read Array Prog. Susp.	
Program (done)	1	0	Status	Read Status	Read Array	Read Config	STS Reconfig Setup	Read Query	Lock Setup	Prot. Prog. Setup	Read Array	
Read Status Both Susp. ⁸	1	0	Status	Read Status Both Susp.	Read Array Both Susp.	Read Config Both Susp.	STS Reconfig Setup Both Susp.	Read Query Both Susp.	Read Array Both Susp.		Read Array Both Susp.	
Read Array Both Susp. ⁸	1	0	Array	Read Status Both Susp.	Read Array Both Susp.	Read Config Both Susp.	STS Reconfig Setup Both Susp.	Read Query Both Susp.	Read Array Both Susp.		Read Array Both Susp.	
Read Config Both Susp. ⁸	1	0	Config	Read Status Both Susp.	Read Array Both Susp.	Read Config Both Susp.	STS Reconfig Setup Both Susp.	Read Query Both Susp.	Read Array Both Susp.		Read Array Both Susp.	
Read Query Both Susp. ⁸	1	0	CFI	Read Status Both Susp.	Read Array Both Susp.	Read Config Both Susp.	STS Reconfig Setup Both Susp.	Read Query Both Susp.	Read Array Both Susp.		Read Array Both Susp.	
BEFP Setup	1	0	Status	Botch (command sequence error)								
BEFP Setup-time	0	1	Status	If Time-out> 5us, go to BEFP Load; If Time-out<5us, stay in BEFP Setup-time								
BEFP Load	0	0	Status	Initialize buffer load count to 31; if buffer count=0, then go to BEFP (busy); For buffer count>0 and same block addr. stay in BEFP Load; if block addr. changed, go to BEFP exit								

Table 25. Next State Table Part B

Current State	SR7	SR0	Data When Read	Command Input and Next State								
				Read Status 0x70	Clear Status ⁴ 0x50	Read Config 0x90	STS Re-config 0xB8	Read Query 0x98	Lock Setup 0x60	OTP/Prot Program Setup 0xC0	Illegal Commands	
BEFP (busy)	0	1	Status	To exit, change block addr; to continue proceed to BEFP after SR0=0.								
BEFP Exit (Busy)	0	1	Status	Internally timed; Go to BEFP Exit after internal timeout; Transition indicated by SR0=0								
BEFP Exit	1	0	Status	Read Status	Read Array	Read Config	STS Reconfig Setup	Read Query	Lock Setup	Prot. Prog. Setup	Read Array	
Write to Buffer setup	1	0	Status	Repeat command until SR7=1. Next cycle will be interpreted as Count Load.								
Count Load	1	0	Status	Word count load (Actual number of words-1). Lowest five bits will be assumed as the count. Device assumes next cycles will be Data Load.								
Data Load	1	0	Status	Data load; To quit or abort, change the block address during a write. The UI will botch on a block change. Repeat Data Load until Word Count is reached, next command must be Write to Buffer Confirm								
Write to Buffer Confirm	1	0	Status	Botch (command sequence error)								
Write to Buffer setup Ers. Susp.	1	0	Status	Repeat command until SR7=1. Next cycle will be interpreted as Count Load Ers. Susp..								
Count Load Ers. Susp.	1	0	Status	Word count load (Actual number of words-1). Lowest five bits will be assumed as the count. Device assumes next cycles will be Data Load Ers. Susp..								
Data Load Ers. Susp.	1	0	Status	Data load; To quit or abort, change the block address during a write. The UI will botch on a block change. Repeat Data Load until Word Count is reached, next command must be Write to Buffer Confirm Ers. Susp.								
Write to Buffer confirm Ers. Susp.	1	0	Status	Botch Ers. Susp. (command sequence error)								
Erase Setup	1	0	Status	Botch (command sequence error)								
Erase (busy)	0	Z	Status	Erase (busy)								
Read Status Ers. Susp.	1	0	Status	Read Status Ers. Susp.	Read Array Ers. Susp.	Read Config Ers. Susp.	STS Reconfig Setup Ers. Susp.	Read Query Ers. Susp.	Lock Setup Ers. Susp.	Read Array Ers. Susp.	Read Array Ers. Susp.	
Read Array Ers. Susp.	1	0	Array	Read Status Ers. Susp.	Read Array Ers. Susp.	Read Config Ers. Susp.	STS Reconfig Setup Ers. Susp.	Read Query Ers. Susp.	Lock Setup Ers. Susp.	Read Array Ers. Susp.	Read Array Ers. Susp.	
Read Config Ers. Susp.	1	0	Config	Read Status Ers. Susp.	Read Array Ers. Susp.	Read Config Ers. Susp.	STS Reconfig Setup Ers. Susp.	Read Query Ers. Susp.	Lock Setup Ers. Susp.	Read Array Ers. Susp.	Read Array Ers. Susp.	
Read Query Ers. Susp.	1	0	CFI	Read Status Ers. Susp.	Read Array Ers. Susp.	Read Config Ers. Susp.	STS Reconfig Setup Ers. Susp.	Read Query Ers. Susp.	Lock Setup Ers. Susp.	Read Array Ers. Susp.	Read Array Ers. Susp.	
Erase (done)	1	0	Status	Read Status	Read Array	Read Config	STS Reconfig Setup	Read Query	Lock Setup	Prot. Prog. Setup	Read Array	
STS Reconfig Setup	1	0	Status	If second cycle is 0x00 or 0x01 or 0x02 or 0x03, then reconfigure the STS functionality and go to Read Status; If not Botch.								
STS Reconfig Setup Ers. Susp.	1	0	Status	If second cycle is 0x00 or 0x01 or 0x02 or 0x03, then reconfigure the STS functionality and go to Read Status Ers. Susp.; If not Botch Ers. Susp.								
STS Reconfig Setup Prog. Susp.	1	0	Status	If second cycle is 0x00 or 0x01 or 0x02 or 0x03, then reconfigure the STS functionality and go to Read Status Prog.Susp.; If not Botch Prog. Susp.								
STS Reconfig Setup Both Susp.	1	0	Status	If second cycle is 0x00 or 0x01 or 0x02 or 0x03, then reconfigure the STS functionality and go to Read Status Both Susp.; If not Botch Both Susp.								

NOTES:

1. For BEFP, the block address should be changed only when the buffer is full.
2. Start address is the address loaded during the Count Load cycle.
3. The Write to Buffer command is invalid when a botch has occurred. The status register should be cleared before issuing the Write to Buffer command.
4. A Clear Status Register command is allowed during erase or program suspend.
5. When a suspend command is issued while the device is busy (program or erase), the device will not enter suspend until the appropriate suspend latency has elapsed. Any additional commands issued during this latency interval will cause indeterminate results.
6. When the lock/write RCR operation is complete, the device returns to Read Status mode. If the Lock Setup command is issued during Erase Suspend, the device will revert to Read Status Ers. Susp.
7. The Confirm command (0xD0) is interpreted as the second cycle of a two-cycle command while a Resume command 0xD0 is interpreted as a stand-alone, single-cycle command. The device will not resume from suspend when the command sequence 0x20, 0xD0 is issued while in suspend state.
8. Both Suspend indicates a Program Suspend nested within an Erase Suspend.
9. A Botch state is indicated when status bits SR4 and SR5 are set, and is the result of an invalid command sequence. The Clear Status Register command (0x50) must be issued to continue.

Appendix B Common Flash Interface

B.1 Query Structure Overview

The Query command causes the flash component to display the Common Flash Interface (CFI) Query structure or “database.” The structure sub-sections and address locations are summarized below. For further details see AP-646 Common Flash Interface (CFI) and Command Sets (Order No 292204) for a full description of CFI.

Table 26. Query Structure⁽¹⁾

Offset	Sub-Section Name	Description
00000h	0089	Manufacturer Code
00001h		Device Code
(BA+2)h ⁽²⁾	Block Status Register	Block-specific information
000(04 -0F)h	Reserved	Reserved for vendor-specific information
00010h	CFI Query Identification String	Command set ID and vendor data offset
0001Bh	System Interface Information	Device timing & voltage information
00027h	Device Geometry Definition	Flash device layout
P ⁽³⁾	Primary Intel-Specific Extended Query Table	Vendor-defined additional information specific to the Primary Vendor Algorithm

NOTES:

1. Refer to the Query Structure Output section and offset 28h for the detailed definition of offset address as a function of device bus width and mode.
2. BA = The beginning location of a Block Address (e.g., 010000h is the beginning location of block 1 when the block size is 64 Kword).
3. Offset 15 defines “P” which points to the Primary Intel-specific Extended Query Table.

B.2 CFI Query Identification String

The Identification String provides verification that the component supports the Common Flash Interface specification. It also indicates the specification version and supported vendor-specified command set(s).

Table 27. CFI Identification

Offset	Length	Description	Addr.	Hex Code	Value
10h	3	Query-unique ASCII string "QRY"	10: 11: 12:	--51 --52 --59	"Q" "R" "Y"
13h	2	Primary vendor command set and control interface ID code. 16-bit ID code for vendor-specified algorithms	13: 14:	--01 --00	
15h	2	Extended Query Table primary algorithm address	15: 16:	--31 --00	
17h	2	Alternate vendor command set and control interface ID code 0000h means no second vendor-specified algorithm exists	17: 18:	--00 --00	
19h	2	Secondary algorithm Extended Query Table address. 0000h means none exists	19: 1A:	--00 --00	

B.3 System Interface Information

The following tables give information on the power supplies and the program and erase time details as output by the device when the system software requests System Interface Information. The values stored are available from an offset address of 1Bh.

Table 28. System Interface Information

Offset	Length	Description	Addr.	Hex Code	Value
1Bh	1	V _{CC} logic supply minimum program/erase voltage bits 0–3 BCD 100 mV bits 4–7 BCD volts	1B:	--27	2.7 V
1Ch	1	V _{CC} logic supply maximum program/erase voltage bits 0–3 BCD 100 mV bits 4–7 BCD volts	1C:	--36	3.6 V
1Dh	1	V _{PP} [programming] supply minimum program/erase voltage bits 0–3 BCD 100 mV bits 4–7 HEX volts	1D:	--00	0.0 V
1Eh	1	V _{PP} [programming] supply maximum program/erase voltage bits 0–3 BCD 100 mV bits 4–7 HEX volts	1E:	--00	0.0 V
1Fh	1	"n" such that typical single word program time-out = 2 ⁿ μs	1F:	--08	256 μs
20h	1	"n" such that typical buffer write time-out = 2 ⁿ μs	20:	--09	512 μs
21h	1	"n" such that typical block erase time-out = 2 ⁿ ms	21:	--0A	1 s
22h	1	"n" such that typical full chip erase time-out = 2 ⁿ ms	22:	--00	n/a
23h	1	"n" such that maximum word program time-out = 2 ⁿ times typical	23:	--01	512 μs
24h	1	"n" such that maximum buffer write time-out = 2 ⁿ times typical	24:	--01	1024 μs
25h	1	"n" such that maximum block erase time-out = 2 ⁿ times typical	25:	--02	4 s
26h	1	"n" such that maximum chip erase time-out = 2 ⁿ times typical	26:	--00	NA

B.4 Device Geometry Definition

The following tables give critical details provided by CFI when the software requests flash device geometry information such as the size of the device, types of read interfaces, program buffer size etc.,

Table 29. Device Geometry Definition

Offset	Length	Description	Address	Hex Value	Meaning																								
27h	1	"n" such that the device size = 2 ⁿ in number of bytes	27:	See Table Below																									
28h	2	Flash Device Interface Code assignments:	28: 29:	--01	x16																								
		<table border="1" style="width: 100%; text-align: center;"> <tr> <td>—</td><td>—</td><td>—</td><td>—</td><td>x64</td><td>x32</td><td>x16</td><td>x8</td> </tr> <tr> <td>15</td><td>14</td><td>13</td><td>12</td><td>11</td><td>10</td><td>9</td><td>8</td> </tr> <tr> <td>—</td><td>—</td><td>—</td><td>—</td><td>—</td><td>—</td><td>—</td><td>—</td> </tr> </table>		—		—	—	—	x64	x32	x16	x8	15	14	13	12	11	10	9	8	—	—	—	—	—	—	—	—	--00
		—		—		—	—	x64	x32	x16	x8																		
15	14	13	12	11	10	9	8																						
—	—	—	—	—	—	—	—																						
2Ah	2	"n" such that maximum number of bytes in write buffer=2 ⁿ	2A: 2B:	--06 --00	64																								
2Ch	1	Number of Erase Blocks Within the Device: 1. x=0 means no erase blocking; the device erases in "bulk" 2. x specifies the number of device or partition regions with one or more contiguous same-size erase blocks 3. Array size = (total blocks) x (individual blocks size)		--01	1																								
2Dh	4	Erase Block Region Information bits 0-15=y, y+1 = number of identical-size erase blocks bits 16-31=z, region erase block(s) size are z x 256 bytes	2D:	See Table Below																									
			2E:																										
			2F:	00																									
			30:	02																									

Table 46a. No of Erase blocks and Erase block region information

Address	64 Mbit	128 Mbit	256 Mbit)
27 h	17h	18h	19h
2D h	3Fh	7Fh	FFh
2E h	00h	00h	00h

B.5 Primary Vendor Specific Extended Query Table

Certain flash features and commands are optional. The Primary Vendor Specific Extended Query Table specifies this and other similar information.

Table 30. Primary Vendor Specific Extended Query Table

Offset ⁽¹⁾ P=31h	Length	Description (Optional Flash Features and Commands)	Add	Hex Code	Value
(P+0)h	3	Primary Extended Query Table Unique ASCII String "PRI"	31:	--50	"P"
(P+1)h			32:	--52	"R"
(P+2)h			33:	--49	"I"
(P+3)h	1	Major version number, ASCII	34:	--31	"1"
(P+4)h	1	Minor version number, ASCII	35:	--31	"1"
(P+5)h (P+6)h (P+7)h (P+8)h	4	Optional feature and command support(1=yes, 0=no) bits 11-31 are reserved; undefined bits are "0". If bit 31 is "1" then another 31 bit field of optional features follows at the end of the 30-bit field. bit 0 - Chip Erase Supported bit 1 - Suspend Erase Supported bit 2 -Suspend Program Supported bit 3 - Legacy lock/unlock Supported bit 4 - Queued Erase Supported bit 5 - Instant Individual Block Locking Supported bit 6 - Protection Bits Supported bit 7 - Page-mode read supported bit 8 - Synchronous Read Supported bit 9 - Simultaneous Operations Supported bit 10 - Feature space Supported	36:	--E6	
			37:	--01	
			38:	--00	
			39:	--00	
			bit 0 = 0		No
			bit 1 = 1		Yes
			bit 2 = 1		Yes
			bit3 = 0		No
			bit 4 = 0		No
			bit 5= 1		Yes
			bit 6= 1		Yes
			bit 7= 1		Yes
			bit 8 = 1		Yes
			bit 9 = 0		No
bit 10 =0		No			
(P+9)h	1	Supported Functions After Suspend: Read Array, Status, Query Other Supported Operations are: bits 1-7 reserved; undefined bits are "0" bit 0 Program supported after erase suspend	3A:	--01	01
			bit 0=1		Yes

Table 30. Primary Vendor Specific Extended Query Table

Offset ⁽¹⁾ P=31h	Length	Description (Optional Flash Features and Commands)	Add	Hex Code	Value
(P+A)h (P+B)h	2	Block Status Register Mask bits 3 -15 are reserved; undefined bits are "0" bit 0 Block Lock-bit status register bit active bit 1 Block Lock down bit status active bit 2 Unlock down bit	3B:	--07	
			3C:	--00	
			bit 0 = 1		Yes
			bit 1 = 1		Yes
(P+C)h	1	Vcc logic supply highest performance program/erase voltage bits 0-3 BCD value in 100mV bits 4-7 BCD value in Volts	3D:	--33	3.3
(P+D)h	1	Vpp optimum program/erase supply voltage bits 0-3 BCD value in 100mV bits 4-7 Hex value in Volts	3E:	--00	--0.0V

Table 31. Protection Register Information

Offset ⁽¹⁾ P=31h	Length	Description(Optional Flash Features and Commands)	Add	Hex Code	Value
(P+E)h	1	Number of Protection register fields in JEDEC ID space. "00h", indicates that 256 protection fields are available	3F:	--02	02
(P+F)h, (P+10)h, (P+11)h, (P+12)h	4	Protection field 1: Protection description This field describes user-available One Time Programmable(OTP) protection register bytes. Some are pre-programmed with device-unique serial numbers. Others are user-programmable. Bits 0-15 point to the protection register lock byte, the section's first byte. The following bytes are factory pre-programmed and user-programmable bits 0-7 = Lock/bytes JEDEC-plane physical low address bits 8-15 =Lock/bytes JEDEC-plane physical high address bits 16-23 = "n" such that 2 ⁿ = factory pre-programmed bytes bits 24-31 = "n" such that 2 ⁿ = user-programmable bytes	40: 41: 42: 43:	--80 --00 --03 --03	80h 00h 8 bytes 8 bytes
(P+13)h, (P+14)h, (P+15)h, (P+16)h, (P+17)h, (P+18)h, (P+19)h, (P+1A)h, (P+1B)h, (P+1C)h	10	Protection field 2: Protection description Bits 0-31 = point to the protection register physical Lock-word address in the Jedec-plane. Following bytes are factory or user-programmable Bits 32-39 ="n"-factory pgm'd groups(low byte) Bits 40-47 ="n"-factory pgm'd groups(high byte) bits 48-55 ="n" such that 2 ⁿ =factory programmable bytes per group bits 56-63 ="n"-user pgm'd groups(low byte) bits 64-71 ="n"-user pgm'd groups(high byte) bits 72-79 ="n" such that 2 ⁿ = user programmable bytes/group	44: 45: 46: 47: 48: 49: 4A: 4B: 4C: 4D:	--89 --00 --00 --00 --00 --00 --00 --10 --00 --04	89h 00h 00h 00h 0 0 0 16 0 16

NOTE: The variable P is a pointer which is defines at CFI offset 15h.

Table 32. Burst/Page Read Information

Offset ⁽¹⁾ P=31h	Length	Description(Optional Flash Features and Commands)	Add	Hex Code	Value
(P+1D)h	1	Page Mode Read Capability bits 0-7="n" such that 2 ⁿ HEX value represents the number of read page bytes. See offset 28h for device word width to determine page mode data output width. 00h indicates no read page buffer.	4E:	--04	16 bytes
(P+1E)h	1	Number of synchronous mode read configuration fields that follow. 00h indicates no burst capability	4F:	--02	2
(P+1F)h	1	Synchronous Mode Read Capability Configuration 1 Bits 3-7 = Reserved bits 0-2 = "n" such that 2 ⁿ⁺¹ HEX value represents the maximum number of continuous synchronous burst reads when the device is configured for its maximum word width. A value of 07h indicates that the device is capable of continuous linear bursts until that will output data until the internal burst counter reaches the end of the device's burstable address space. This field's 3-bit value can be written directly to the Read Configuration Register Bits 0-2 if the device is configured for its maximum word width. See offset 28h for word width to determine the burst data output width.	50:	--02	8
(P+20)h	1	Synchronous Mode Read Capability Configuration 2	51:	--03	16

Appendix C Flowcharts

Figure 25. Write to Buffer Flowchart

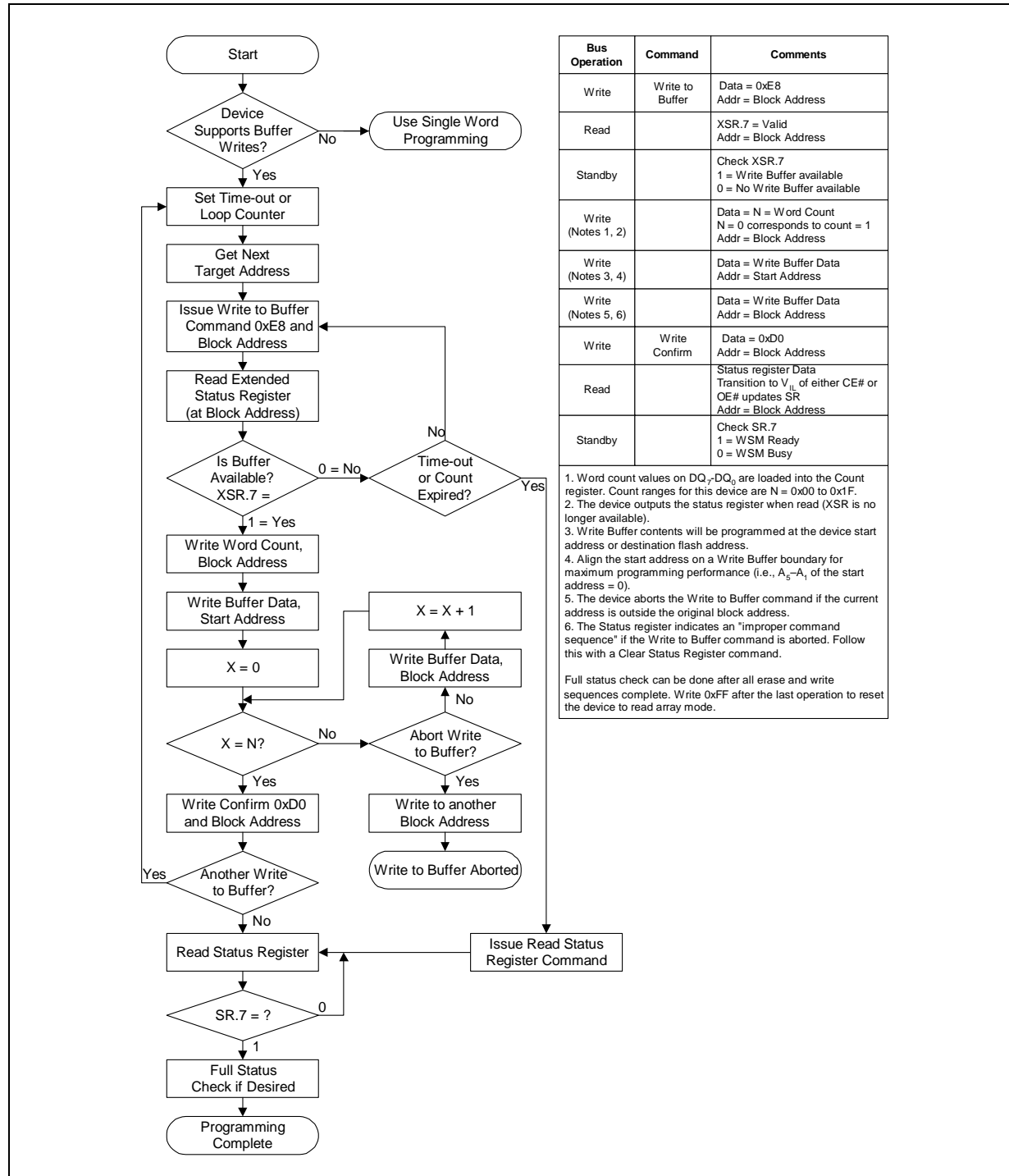
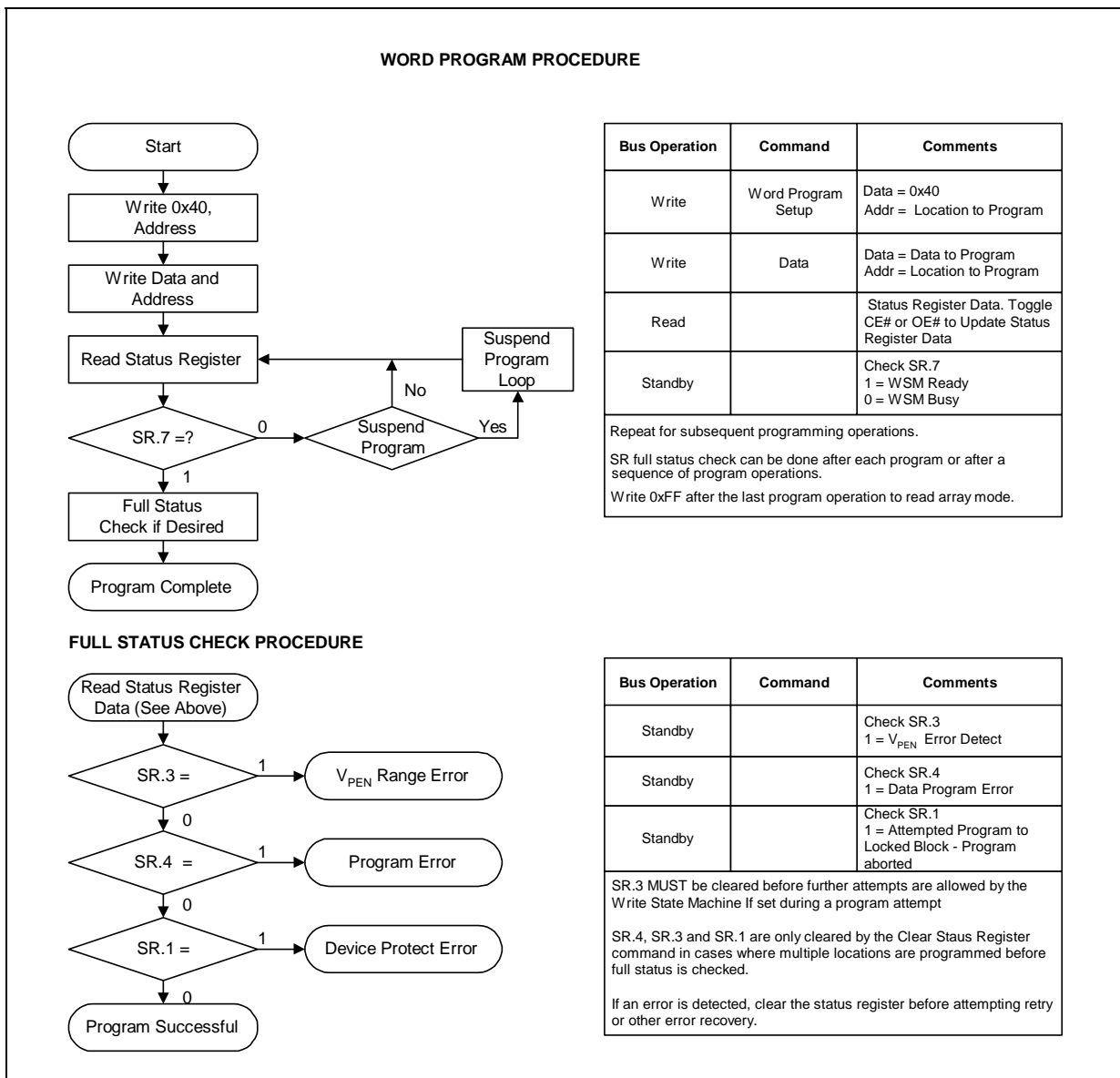


Figure 26. Word Programming Flowchart



Bus Operation	Command	Comments
Write	Word Program Setup	Data = 0x40 Addr = Location to Program
Write	Data	Data = Data to Program Addr = Location to Program
Read		Status Register Data. Toggle CE# or OE# to Update Status Register Data
Standby		Check SR.7 1 = WSM Ready 0 = WSM Busy

Repeat for subsequent programming operations.
SR full status check can be done after each program or after a sequence of program operations.
Write 0xFF after the last program operation to read array mode.

FULL STATUS CHECK PROCEDURE

```

    graph TD
      ReadSRData([Read Status Register Data (See Above)]) --> SR3{SR.3 =}
      SR3 -- 1 --> Vpen[V_PEN Range Error]
      SR3 -- 0 --> SR4{SR.4 =}
      SR4 -- 1 --> ProgramError([Program Error])
      SR4 -- 0 --> SR1{SR.1 =}
      SR1 -- 1 --> DeviceProtect([Device Protect Error])
      SR1 -- 0 --> Successful([Program Successful])
  
```

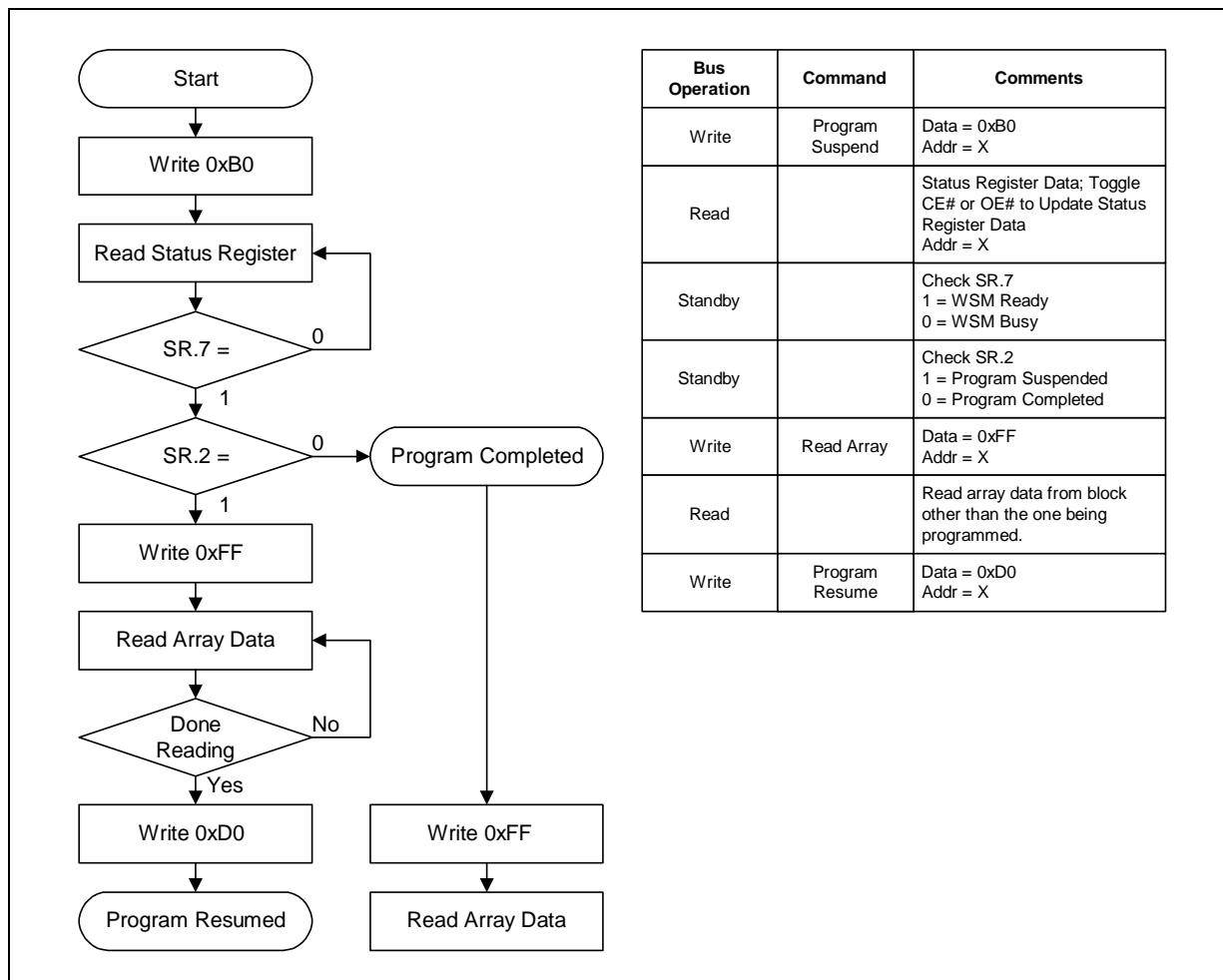
Bus Operation	Command	Comments
Standby		Check SR.3 1 = V _{PEN} Error Detect
Standby		Check SR.4 1 = Data Program Error
Standby		Check SR.1 1 = Attempted Program to Locked Block - Program aborted

SR.3 MUST be cleared before further attempts are allowed by the Write State Machine If set during a program attempt

SR.4, SR.3 and SR.1 are only cleared by the Clear Status Register command in cases where multiple locations are programmed before full status is checked.

If an error is detected, clear the status register before attempting retry or other error recovery.

Figure 27. Program Suspend/Resume Flowchart



Bus Operation	Command	Comments
Write	Program Suspend	Data = 0xB0 Addr = X
Read		Status Register Data; Toggle CE# or OE# to Update Status Register Data Addr = X
Standby		Check SR.7 1 = WSM Ready 0 = WSM Busy
Standby		Check SR.2 1 = Program Suspended 0 = Program Completed
Write	Read Array	Data = 0xFF Addr = X
Read		Read array data from block other than the one being programmed.
Write	Program Resume	Data = 0xD0 Addr = X

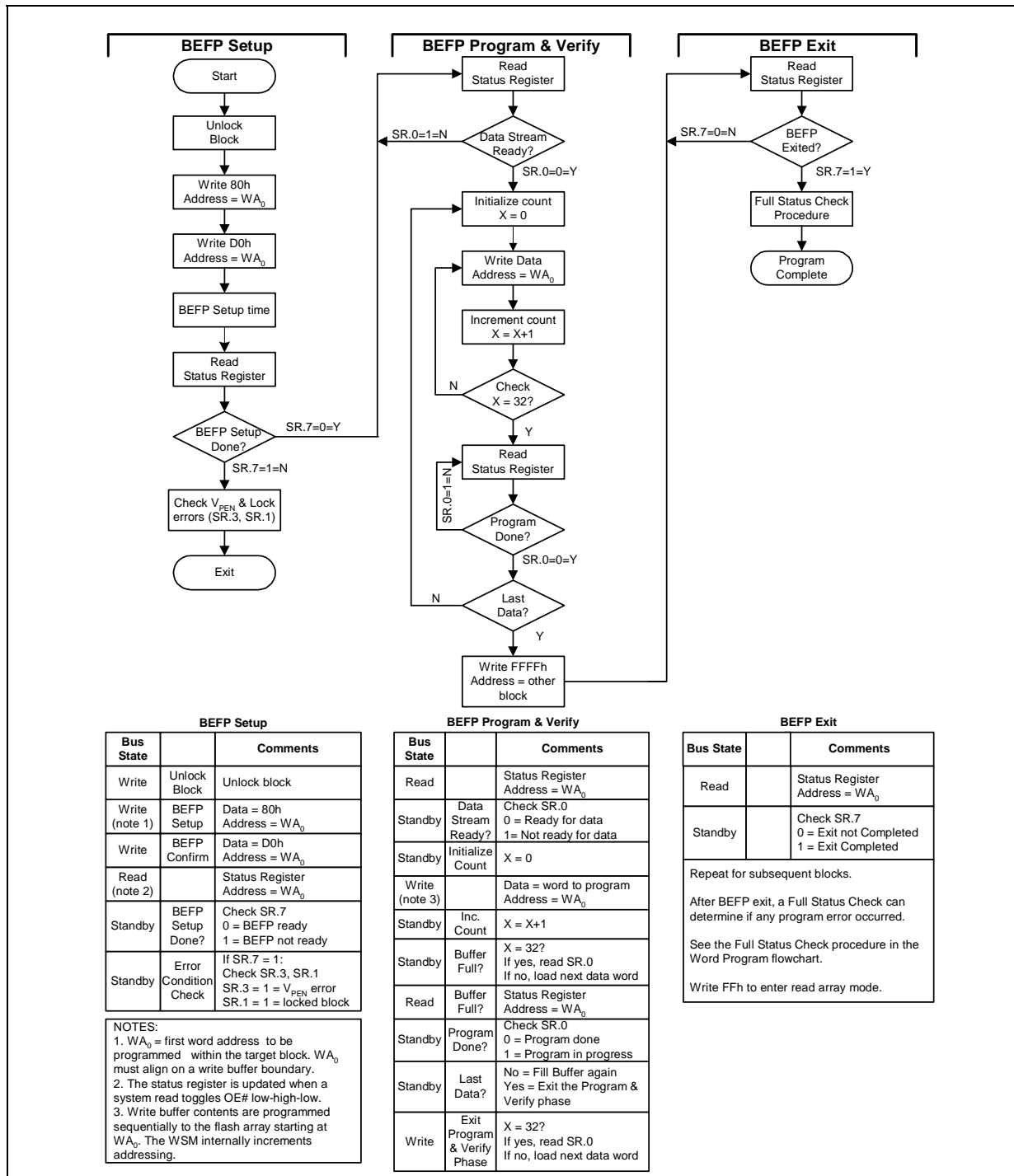
Figure 28. Buffered Enhanced Factory Programming Procedure Flowchart


Figure 29. Block Erase Flowchart

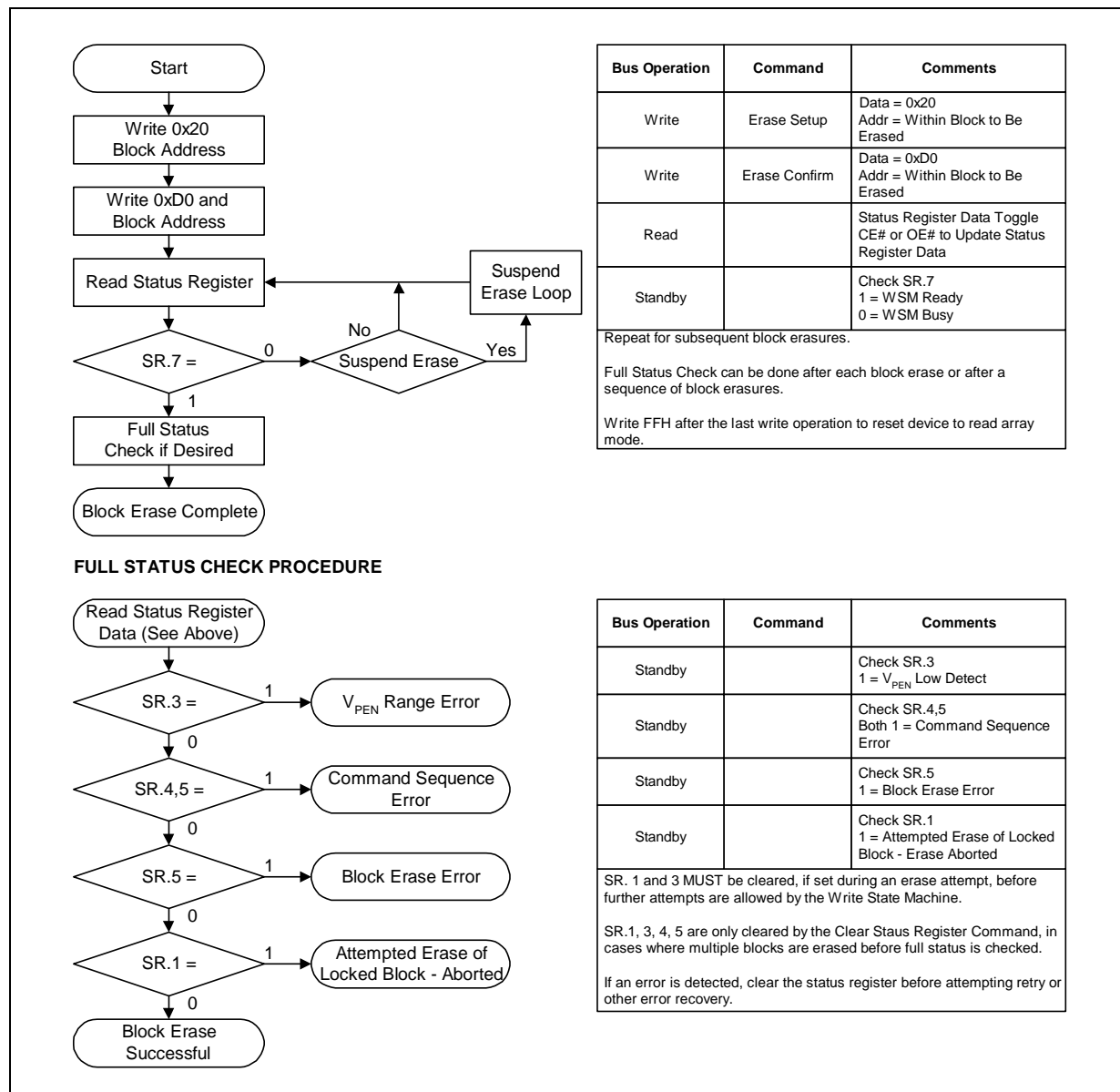


Figure 30. Erase Suspend/Resume Flowchart

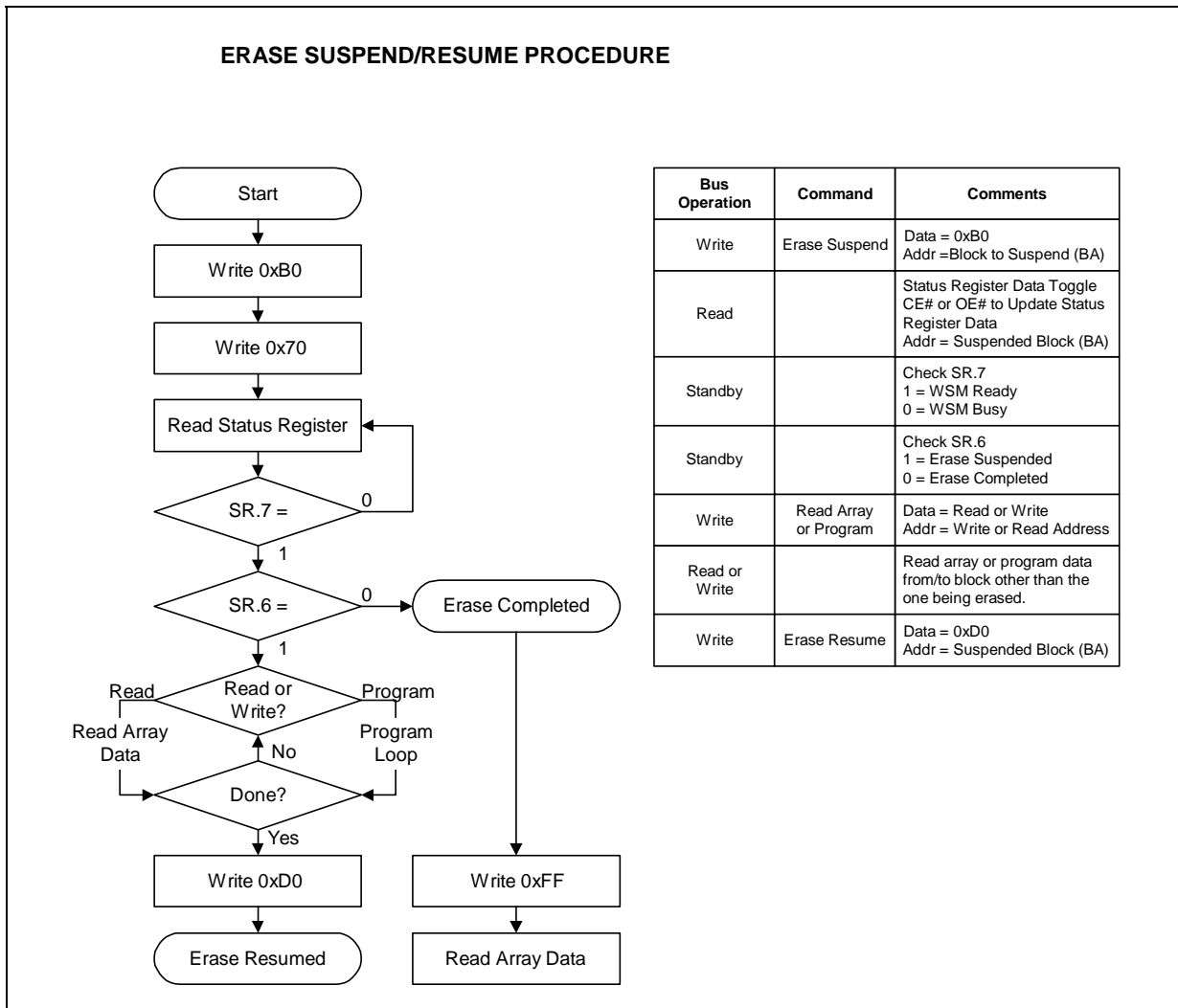


Figure 31. Protection Register Programming Flowchart

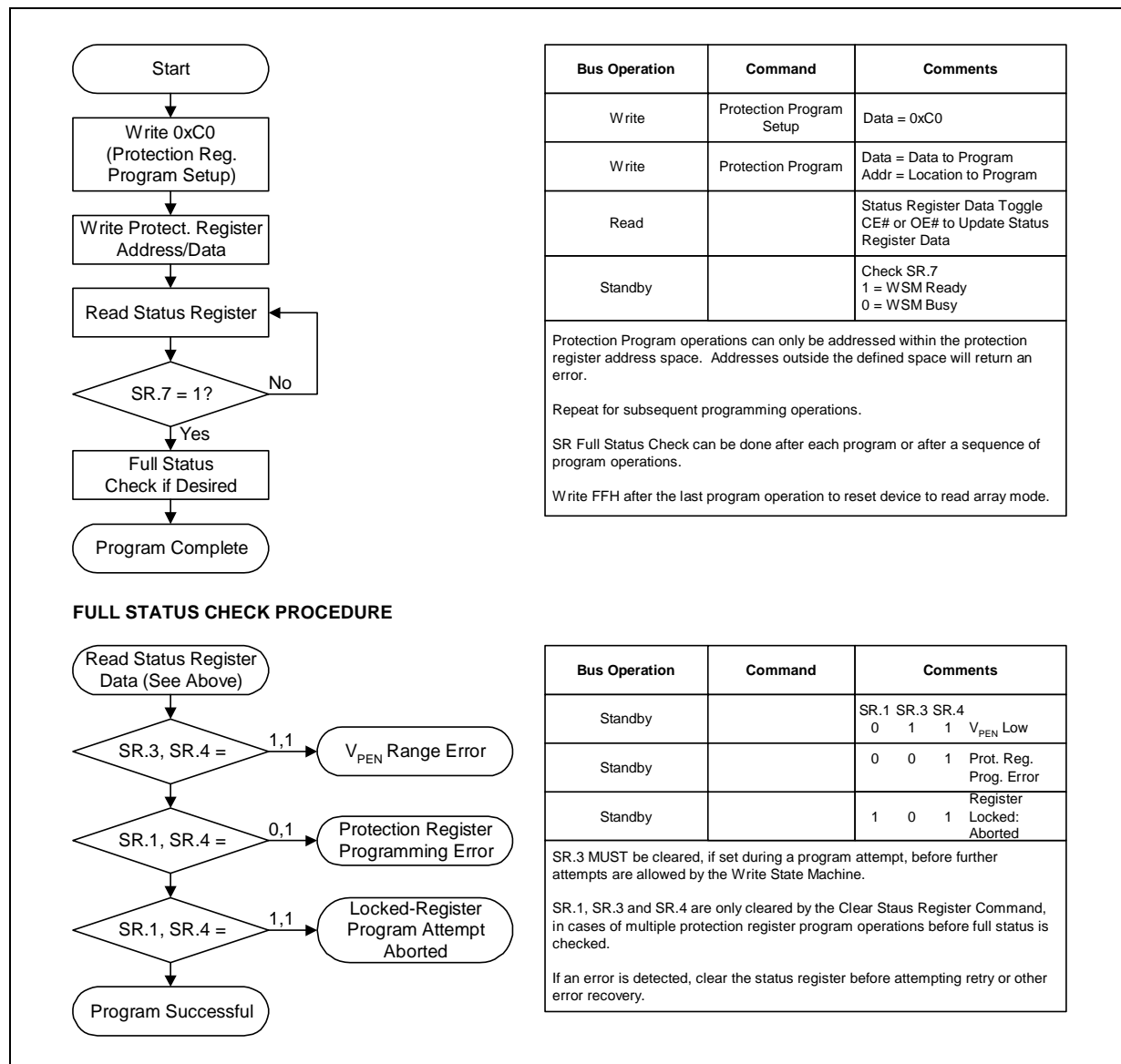
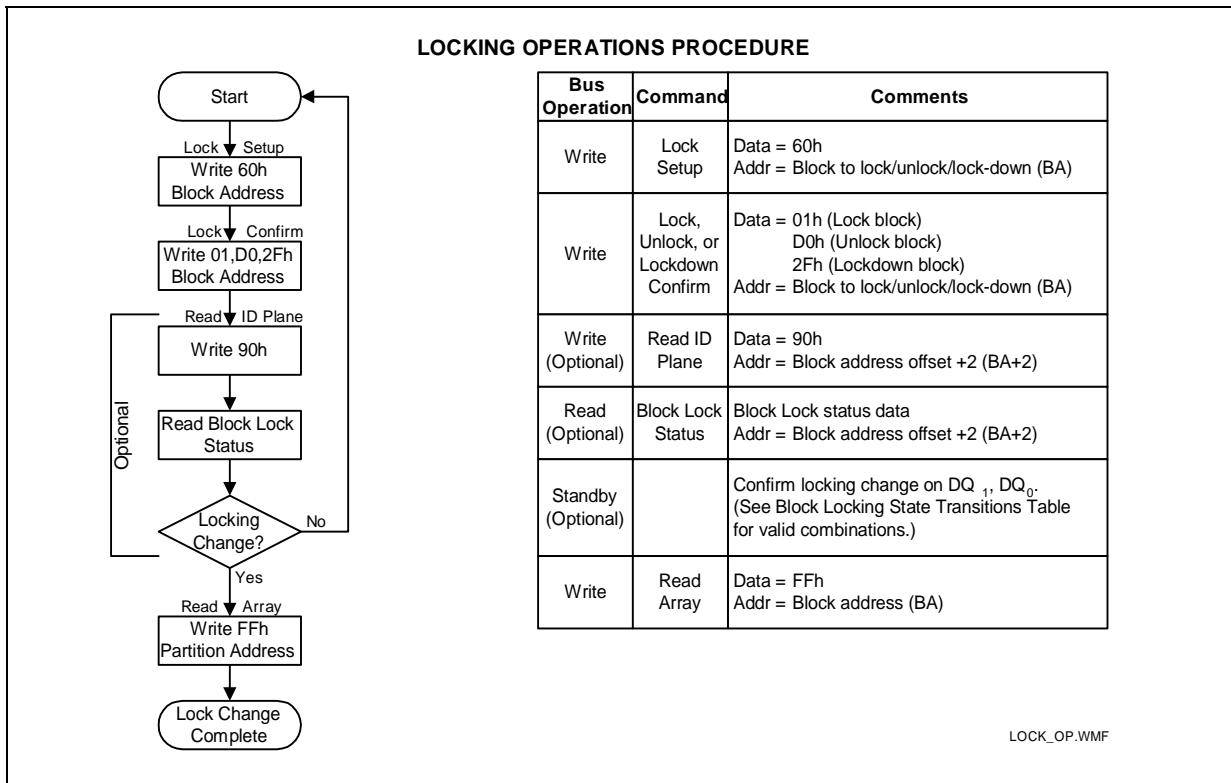


Figure 32. Block Lock Operations Flowchart



Appendix D Additional Information

Order Number	Document Tool
298636	<i>Intel StrataFlash[®] Synchronous Memory (K3/K18) 256-, 128-, 64-Mbit Specification Update</i>
298136	<i>Intel[®] Persistent Storage Manager User's Guide</i>
292237	<i>AP-689 Using Intel[®] Persistent Storage Manager</i>
297859	<i>AP-677 Intel StrataFlash[®] Memory Technology</i>
292222	<i>AP-644 Designing Intel StrataFlash[®] Memory into Intel[®] Architecture</i>
292221	<i>AP-663 Using the Intel StrataFlash[®] Memory Write Buffer</i>
292204	<i>AP-646 Common Flash Interface (CFI) and Command Sets</i>
292202	<i>AP-644 Migration Guide to 5 Volt Intel StrataFlash[®] Memory</i>
298161	<i>Intel[®] Flash Memory Chip Scale Package User's Guide</i>

NOTES:

1. Please call the Intel Literature Center at (800) 548-4725 to request Intel documentation. International customers should contact their local Intel or distribution sales office.
2. Visit Intel's World Wide Web home page at <http://www.intel.com> for technical documentation and tools.
3. For the most current information on Intel StrataFlash memory, visit our website at <http://developer.intel.com/design/flash/isf>.

Appendix E Ordering Information

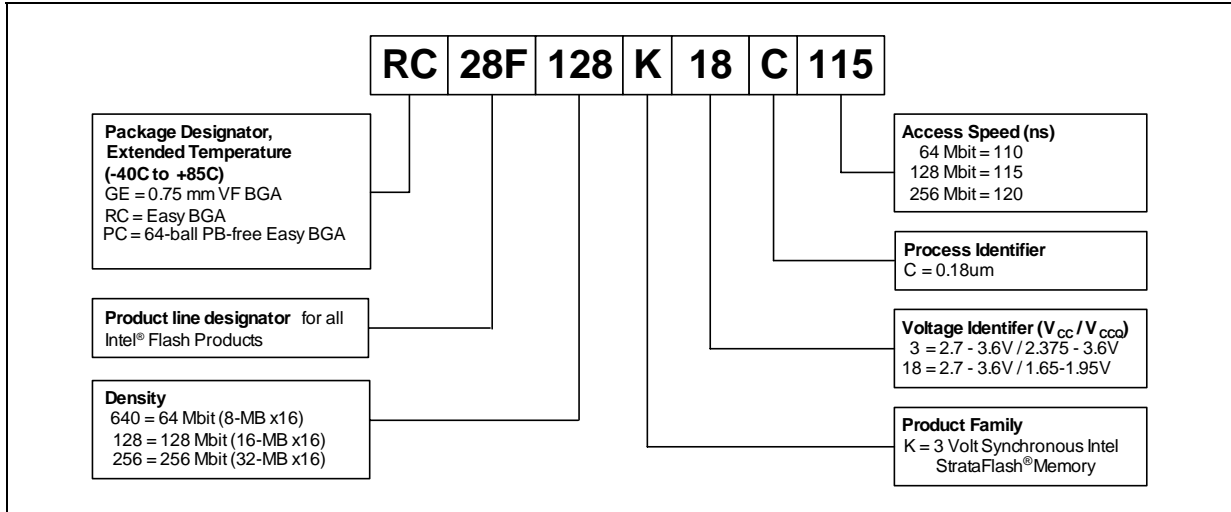


Table 33. Valid Combinations

Density	VF BGA	Easy BGA	Lead-free Easy BGA
64 Mbit	GE28F640K3C110 GE28F640K18C110	RC28F640K3C110 RC28F640K18C110	Not Available
128 Mbit	GE28F128K3C115 GE28F128K18C115	RC28F128K3C115 RC28F128K18C115	PC 28F128K3C115 (144 PC Tray)
256 Mbit	GE28F256K3C120 GE28F256K18C120	RC28F256K3C120 RC28F256K18C120	Not Available



Looking for pricing, stock, or lifecycle information?

Click below to explore more details on WIN SOURCE:

 [View RC28F128K3C on WIN SOURCE](#)

 [Intel Information](#)

Optimize Your Supply Chain with WIN SOURCE Solutions

-  Global Sourcing Solution
-  Obsolete Management
-  Cost Control Management
-  Shortage Management
-  Alternative Solution
-  Excess Inventory Management