

To our customers,

---

## Old Company Name in Catalogs and Other Documents

---

On April 1<sup>st</sup>, 2010, NEC Electronics Corporation merged with Renesas Technology Corporation, and Renesas Electronics Corporation took over all the business of both companies. Therefore, although the old company name remains in this document, it is a valid Renesas Electronics document. We appreciate your understanding.

Renesas Electronics website: <http://www.renesas.com>

April 1<sup>st</sup>, 2010  
Renesas Electronics Corporation

Issued by: Renesas Electronics Corporation (<http://www.renesas.com>)

Send any inquiries to <http://www.renesas.com/inquiry>.

## Notice

1. All information included in this document is current as of the date this document is issued. Such information, however, is subject to change without any prior notice. Before purchasing or using any Renesas Electronics products listed herein, please confirm the latest product information with a Renesas Electronics sales office. Also, please pay regular and careful attention to additional and different information to be disclosed by Renesas Electronics such as that disclosed through our website.
2. Renesas Electronics does not assume any liability for infringement of patents, copyrights, or other intellectual property rights of third parties by or arising from the use of Renesas Electronics products or technical information described in this document. No license, express, implied or otherwise, is granted hereby under any patents, copyrights or other intellectual property rights of Renesas Electronics or others.
3. You should not alter, modify, copy, or otherwise misappropriate any Renesas Electronics product, whether in whole or in part.
4. Descriptions of circuits, software and other related information in this document are provided only to illustrate the operation of semiconductor products and application examples. You are fully responsible for the incorporation of these circuits, software, and information in the design of your equipment. Renesas Electronics assumes no responsibility for any losses incurred by you or third parties arising from the use of these circuits, software, or information.
5. When exporting the products or technology described in this document, you should comply with the applicable export control laws and regulations and follow the procedures required by such laws and regulations. You should not use Renesas Electronics products or the technology described in this document for any purpose relating to military applications or use by the military, including but not limited to the development of weapons of mass destruction. Renesas Electronics products and technology may not be used for or incorporated into any products or systems whose manufacture, use, or sale is prohibited under any applicable domestic or foreign laws or regulations.
6. Renesas Electronics has used reasonable care in preparing the information included in this document, but Renesas Electronics does not warrant that such information is error free. Renesas Electronics assumes no liability whatsoever for any damages incurred by you resulting from errors in or omissions from the information included herein.
7. Renesas Electronics products are classified according to the following three quality grades: "Standard", "High Quality", and "Specific". The recommended applications for each Renesas Electronics product depends on the product's quality grade, as indicated below. You must check the quality grade of each Renesas Electronics product before using it in a particular application. You may not use any Renesas Electronics product for any application categorized as "Specific" without the prior written consent of Renesas Electronics. Further, you may not use any Renesas Electronics product for any application for which it is not intended without the prior written consent of Renesas Electronics. Renesas Electronics shall not be in any way liable for any damages or losses incurred by you or third parties arising from the use of any Renesas Electronics product for an application categorized as "Specific" or for which the product is not intended where you have failed to obtain the prior written consent of Renesas Electronics. The quality grade of each Renesas Electronics product is "Standard" unless otherwise expressly specified in a Renesas Electronics data sheets or data books, etc.
  - "Standard": Computers; office equipment; communications equipment; test and measurement equipment; audio and visual equipment; home electronic appliances; machine tools; personal electronic equipment; and industrial robots.
  - "High Quality": Transportation equipment (automobiles, trains, ships, etc.); traffic control systems; anti-disaster systems; anti-crime systems; safety equipment; and medical equipment not specifically designed for life support.
  - "Specific": Aircraft; aerospace equipment; submersible repeaters; nuclear reactor control systems; medical equipment or systems for life support (e.g. artificial life support devices or systems), surgical implantations, or healthcare intervention (e.g. excision, etc.), and any other applications or purposes that pose a direct threat to human life.
8. You should use the Renesas Electronics products described in this document within the range specified by Renesas Electronics, especially with respect to the maximum rating, operating supply voltage range, movement power voltage range, heat radiation characteristics, installation and other product characteristics. Renesas Electronics shall have no liability for malfunctions or damages arising out of the use of Renesas Electronics products beyond such specified ranges.
9. Although Renesas Electronics endeavors to improve the quality and reliability of its products, semiconductor products have specific characteristics such as the occurrence of failure at a certain rate and malfunctions under certain use conditions. Further, Renesas Electronics products are not subject to radiation resistance design. Please be sure to implement safety measures to guard them against the possibility of physical injury, and injury or damage caused by fire in the event of the failure of a Renesas Electronics product, such as safety design for hardware and software including but not limited to redundancy, fire control and malfunction prevention, appropriate treatment for aging degradation or any other appropriate measures. Because the evaluation of microcomputer software alone is very difficult, please evaluate the safety of the final products or system manufactured by you.
10. Please contact a Renesas Electronics sales office for details as to environmental matters such as the environmental compatibility of each Renesas Electronics product. Please use Renesas Electronics products in compliance with all applicable laws and regulations that regulate the inclusion or use of controlled substances, including without limitation, the EU RoHS Directive. Renesas Electronics assumes no liability for damages or losses occurring as a result of your noncompliance with applicable laws and regulations.
11. This document may not be reproduced or duplicated, in any form, in whole or in part, without prior written consent of Renesas Electronics.
12. Please contact a Renesas Electronics sales office if you have any questions regarding the information contained in this document or Renesas Electronics products, or if you have any other inquiries.

(Note 1) "Renesas Electronics" as used in this document means Renesas Electronics Corporation and also includes its majority-owned subsidiaries.

(Note 2) "Renesas Electronics product(s)" means any product developed or manufactured by or for Renesas Electronics.

# R1EX24064ASAS0A

# R1EX24064ATAS0A

Two-wire serial interface  
64k EEPROM (8-kword × 8-bit)

REJ03C0332-0200

Rev.2.00

Oct. 26, 2009

---

## Description

R1EX24xxx series are two-wire serial interface EEPROM (Electrically Erasable and Programmable ROM). They realize high speed, low power consumption and a high level of reliability by employing advanced MONOS memory technology and CMOS process and low voltage circuitry technology. They also have a 32-byte page programming function to make their write operation faster.

Note: Renesas Technology's serial EEPROM are authorized for using consumer applications such as cellular phone, camcorders, audio equipment. Therefore, please contact Renesas Technology's sales office before using industrial applications such as automotive systems, embedded controllers, and meters.

## Features

- Single supply: 1.8 V to 5.5 V
- Two-wire serial interface (I<sup>2</sup>C serial bus)
- Clock frequency: 400 kHz
- Power dissipation:
  - Standby: 2 μA (max)
  - Active (Read): 1 mA (max)
  - Active (Write): 3.0 mA (max)
- Automatic page write: 32-byte/page
- Write cycle time: 5 ms
- Endurance: 1,000k Cycles @ 25°C
- Data retention: 100 Years @ 25°C

## R1EX24064AxxS0A

Small size packages: SOP-8pin, TSSOP-8pin

- Shipping tape and reel
  - TSSOP 8-pin: 3,000 IC/reel
  - SOP 8-pin: 2,500 IC/reel
- Temperature range:  $-40$  to  $+85^{\circ}\text{C}$
- Lead free products.

## Ordering Information

Type No.	Internal organization	Operating voltage	Frequency	Package
R1EX24064ASAS0A	64k bit (8192 $\times$ 8-bit)	1.8 V to 5.5 V	400 kHz	150 mil 8-pin plastic SOP PRSP0008DF-B (FP-8DBV) Lead free
R1EX24064ATAS0A	64k bit (8192 $\times$ 8-bit)	1.8 V to 5.5 V	400 kHz	8-pin plastic TSSOP PTSP0008JC-B (TTP-8DAV) Lead free

## Pin Arrangement

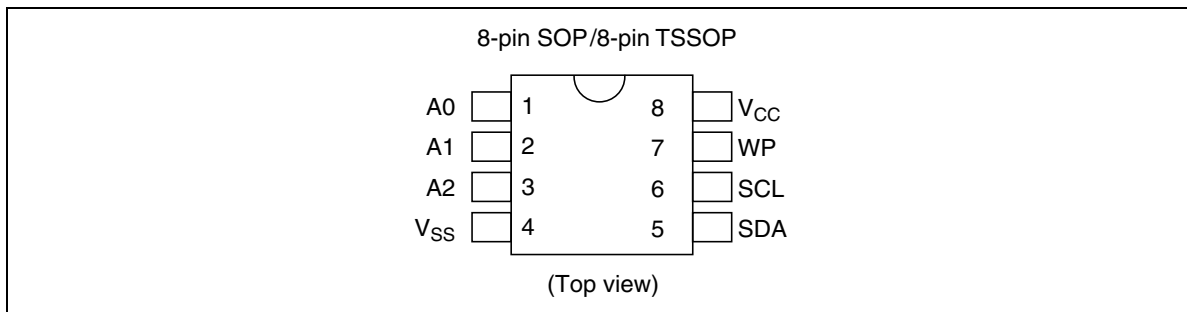

## Pin Description

Pin name	Function
A0 to A2	Device address
SCL	Serial clock input
SDA	Serial data input/output
WP	Write protect
$V_{CC}$	Power supply
$V_{SS}$	Ground

## Block Diagram

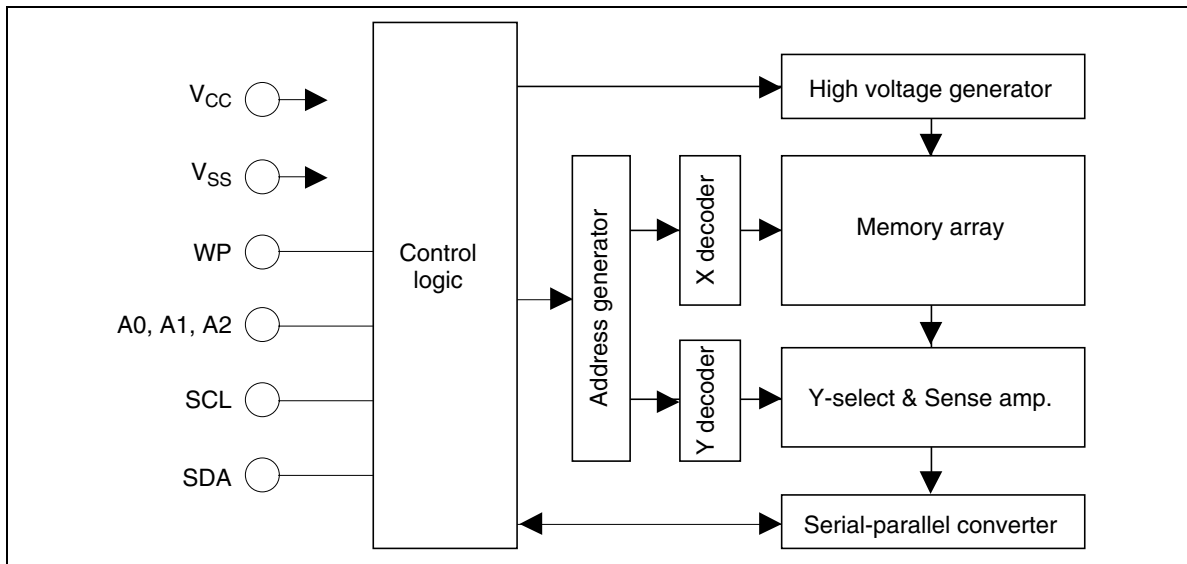

## Absolute Maximum Ratings

Parameter	Symbol	Value	Unit
Supply voltage relative to $V_{SS}$	$V_{CC}$	-0.6 to +7.0	V
Input voltage relative to $V_{SS}$	$V_{in}$	-0.5* <sup>2</sup> to +7.0* <sup>3</sup>	V
Operating temperature range* <sup>1</sup>	$T_{opr}$	-40 to +85	°C
Storage temperature range	$T_{stg}$	-55 to +125	°C

Notes: 1. Including electrical characteristics and data retention.

2.  $V_{in}$  (min): -3.0 V for pulse width  $\leq$  50 ns.

3. Should not exceed  $V_{CC} + 1.0$  V.

## DC Operating Conditions

Parameter	Symbol	Min	Typ	Max	Unit
Supply voltage	$V_{CC}$	1.8	—	5.5	V
	$V_{SS}$	0	0	0	V
Input high voltage	$V_{IH}$	$V_{CC} \times 0.7$	—	$V_{CC} + 0.5$	V
Input low voltage	$V_{IL}$	-0.3* <sup>1</sup>	—	$V_{CC} \times 0.3$	V
Operating temperature	$T_{opr}$	-40	—	+85	°C

Notes: 1.  $V_{IL}$  (min): -1.0 V for pulse width  $\leq$  50 ns.

## R1EX24064AxxS0A

### DC Characteristics (Ta = -40 to +85°C, V<sub>CC</sub> = 1.8 V to 5.5 V)

Parameter	Symbol	Min	Typ	Max	Unit	Test conditions
Input leakage current	I <sub>LI</sub>	—	—	2.0	μA	V <sub>CC</sub> = 5.5 V, Vin = 0 to 5.5 V
Output leakage current	I <sub>LO</sub>	—	—	2.0	μA	V <sub>CC</sub> = 5.5 V, Vout = 0 to 5.5 V
Standby V <sub>CC</sub> current	I <sub>SB</sub>	—	1.0	2.0	μA	Vin = V <sub>SS</sub> or V <sub>CC</sub>
Read V <sub>CC</sub> current	I <sub>CC1</sub>	—	—	1.0	mA	V <sub>CC</sub> = 5.5 V, Read at 400 kHz
Write V <sub>CC</sub> current	I <sub>CC2</sub>	—	—	3.0	mA	V <sub>CC</sub> = 5.5 V, Write at 400 kHz
Output low voltage	V <sub>OL2</sub>	—	—	0.4	V	V <sub>CC</sub> = 2.7 to 5.5 V, I <sub>OL</sub> = 3.0 mA
	V <sub>OL1</sub>	—	—	0.2	V	V <sub>CC</sub> = 1.8 to 2.7 V, I <sub>OL</sub> = 1.5 mA

### Capacitance (Ta = +25°C, f = 1 MHz)

Parameter	Symbol	Min	Typ	Max	Unit	Test conditions
Input capacitance (A0 to A2, SCL, WP)	C <sub>in</sub> * <sup>1</sup>	—	—	6.0	pF	Vin = 0 V
Output capacitance (SDA)	C <sub>IO</sub> * <sup>1</sup>	—	—	6.0	pF	Vout = 0 V

Note: 1. Not 100% tested.

### Memory cell characteristics (V<sub>CC</sub> = 1.8 V to 5.5 V)

	Ta=25°C	Ta=85°C	Notes
Endurance	1,000k Cycles min.	100k Cycles min	1
Data retention	100 Years min.	10 Years min.	1

Notes: 1. Not 100% tested.

**AC Characteristics** ( $T_a = -40$  to  $+85^\circ\text{C}$ ,  $V_{CC} = 1.8$  to  $5.5$  V)**Test Conditions**

- Input pules levels:
  - $V_{IL} = 0.2 \times V_{CC}$
  - $V_{IH} = 0.8 \times V_{CC}$
- Input rise and fall time:  $\leq 20$  ns
- Input and output timing reference levels:  $0.5 \times V_{CC}$
- Output load: TTL Gate + 100 pF

Parameter	Symbol	Min	Typ	Max	Unit	Notes
Clock frequency	$f_{SCL}$	—	—	400	kHz	
Clock pulse width low	$t_{LOW}$	1200	—	—	ns	
Clock pulse width high	$t_{HIGH}$	600	—	—	ns	
Noise suppression time	$t_I$	—	—	50	ns	1
Access time	$t_{AA}$	100	—	900	ns	
Bus free time for next mode	$t_{BUF}$	1200	—	—	ns	
Start hold time	$t_{HD,STA}$	600	—	—	ns	
Start setup time	$t_{SU,STA}$	600	—	—	ns	
Data in hold time	$t_{HD,DAT}$	0	—	—	ns	
Data in setup time	$t_{SU,DAT}$	100	—	—	ns	
Input rise time	$t_R$	—	—	300	ns	1
Input fall time	$t_F$	—	—	300	ns	1
Stop setup time	$t_{SU,STO}$	600	—	—	ns	
Data out hold time	$t_{DH}$	50	—	—	ns	
Write protect hold time	$t_{HD,WP}$	1200	—	—	ns	
Write protect setup time	$t_{SU,WP}$	0	—	—	ns	
Write cycle time	$t_{WC}$	—	—	5	ms	2

Notes: 1. Not 100% tested.

2.  $t_{WC}$  is the time from a stop condition to the end of internally controlled write cycle.

## Timing Waveforms

### Bus Timing

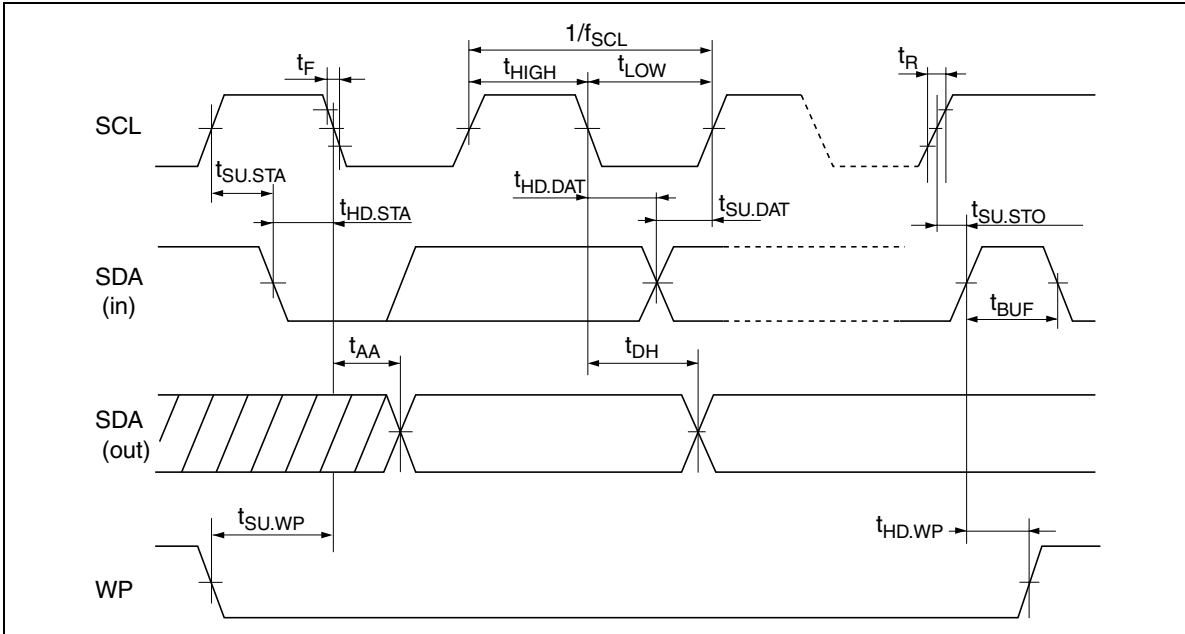

### Write Cycle Timing

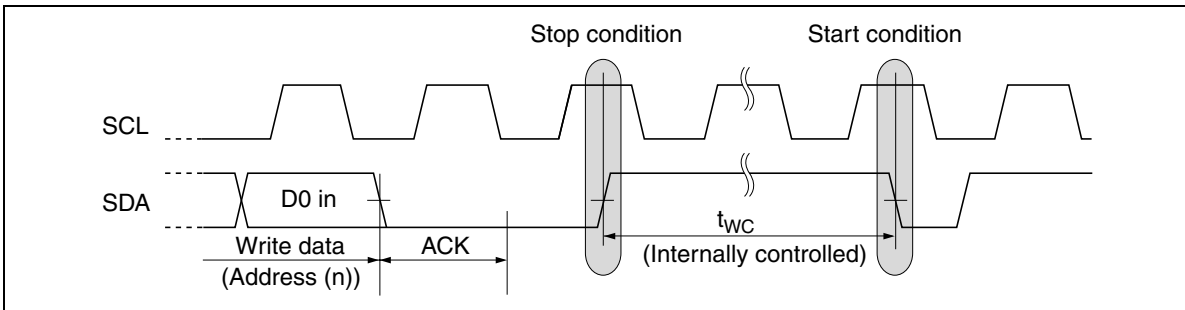

## Pin Function

### Serial Clock (SCL)

The SCL pin is used to control serial input/output data timing. The SCL input is used to positive edge clock data into EEPROM device and negative edge clock data out of each device. Maximum clock rate is 400 kHz.

### Serial Input/Output Data (SDA)

The SDA pin is bidirectional for serial data transfer. The SDA pin needs to be pulled up by resistor as that pin is open-drain driven structure. Use proper resistor value for your system by considering  $V_{OL}$ ,  $I_{OL}$  and the SDA pin capacitance. Except for a start condition and a stop condition which will be discussed later, the SDA transition needs to be completed during the SCL low period.

### Data Validity (SDA data change timing waveform)

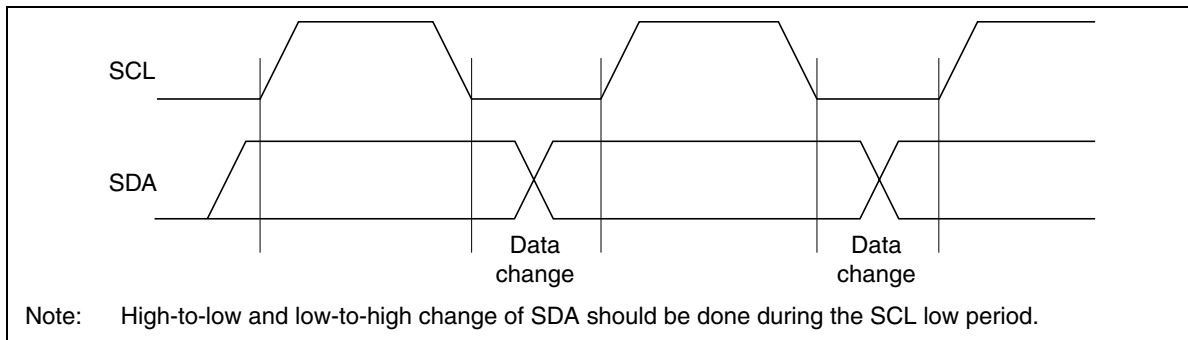

## R1EX24064AxxS0A

---

### Device Address (A0, A1, A2)

Eight devices can be wired for one common data bus line as maximum. Device address pins are used to distinguish each device and device address pins should be connected to  $V_{CC}$  or  $V_{SS}$ . When device address code provided from SDA pin matches corresponding hard-wired device address pins A0 to A2, that one device can be activated.

These pins are internally pulled-down to  $V_{SS}$ . The device reads these pins as Low if unconnected.

### Pin Connections for A0 to A2

Memory size	Max connect number	Pin connection			Note
		A2	A1	A0	
64k bit	8	$V_{CC}/V_{SS}$	$V_{CC}/V_{SS}$	$V_{CC}/V_{SS}$	

Note: 1. During floating, " $V_{CC}/V_{SS}$ " are fixed to  $V_{SS}$ .

### Write Protect (WP)

When the Write Protect pin (WP) is high, the write protection feature is enabled and operates as shown in the following table.

Also, acknowledgment "0" is outputted after inputting device address and memory address. After inputting write data, acknowledgment "1" (**NO ACK**) is outputted.

When the WP is low, write operation for all memory arrays are allowed. The read operation is always activated irrespective of the WP pin status.

The WP pin is internally pulled-down to  $V_{SS}$ . Write operations for all memory array are allowed if unconnected.

### Write Protect Area

WP pin status	Write protect area
	64k bit
$V_{IH}$	Full (64k bit)
$V_{IL}$	Normal read/write operation

## Functional Description

### Start Condition

A high-to-low transition of the SDA with the SCL high is needed in order to start read, write operation (See start condition and stop condition).

### Stop Condition

A low-to-high transition of the SDA with the SCL high is a stop condition. The stand-by operation starts after a read sequence by a stop condition. In the case of write operation, a stop condition terminates the write data inputs and place the device in a internally-timed write cycle to the memories. After the internally-timed write cycle which is specified as  $t_{WC}$ , the device enters a standby mode (See write cycle timing).

### Start Condition and Stop Condition

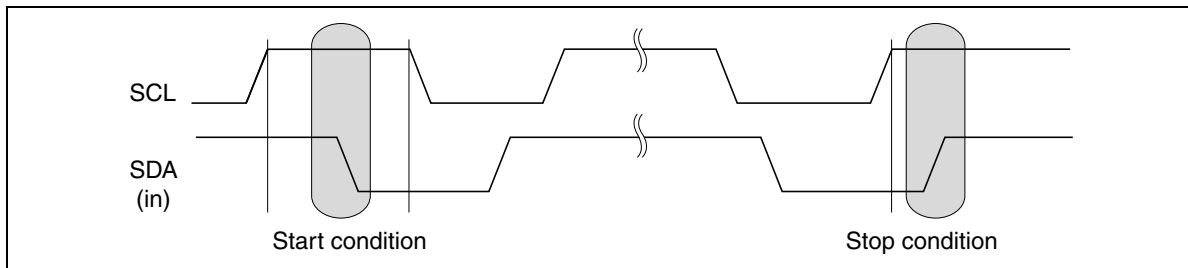

### Acknowledge

All addresses and data words are serially transmitted to and from in 8-bit words. The receiver sends a zero to acknowledge that it has received each word. This happens during ninth clock cycle. The transmitter keeps bus open to receive acknowledgment from the receiver at the ninth clock. In the write operation, EEPROM sends a zero to acknowledge after receiving every 8-bit words. In the read operation, EEPROM sends a zero to acknowledge after receiving the device address word. After sending read data, the EEPROM waits acknowledgment by keeping bus open. If the EEPROM receives zero as an acknowledge, it sends read data of next address. If the EEPROM receives acknowledgment "1" (no acknowledgment) and a following stop condition, it stops the read operation and enters a stand-by mode. If the EEPROM receives neither acknowledgment "0" nor a stop condition, the EEPROM keeps bus open without sending read data.

### Acknowledge Timing Waveform

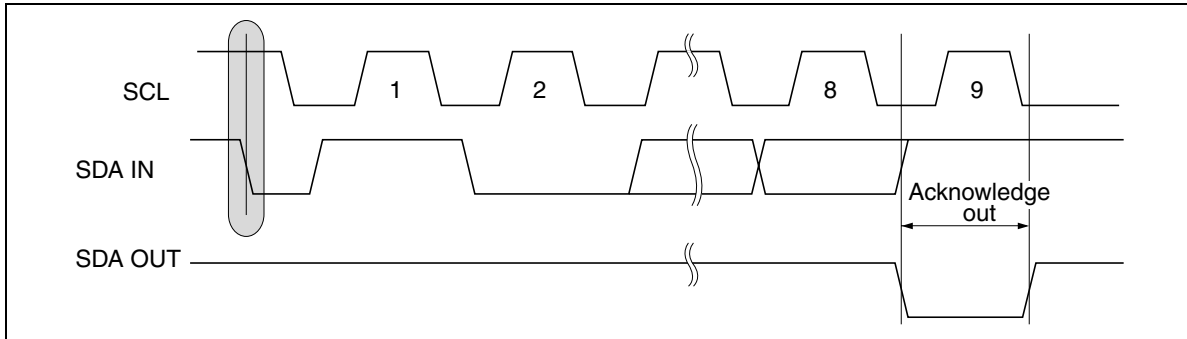

### Device Addressing

The EEPROM device requires an 8-bit device address word following a start condition to enable the chip for a read or a write operation. The device address word consists of 4-bit device code, 3-bit device address code and 1-bit read/write(R/W) code. The most significant 4-bit of the device address word are used to distinguish device type and this EEPROM uses “1010” fixed code. The device address word is followed by the 3-bit device address code in the order of A2, A1, A0. The device address code selects one device out of all devices which are connected to the bus. This means that the device is selected if the inputted 3-bit device address code is equal to the corresponding hard-wired A2-A0 pin status. The eighth bit of the device address word is the read/write(R/W) bit. A write operation is initiated if this bit is low and a read operation is initiated if this bit is high. Upon a compare of the device address word, the EEPROM enters the read or write operation after outputting the zero as an acknowledge. The EEPROM turns to a stand-by state if the device code is not “1010” or device address code doesn’t coincide with status of the correspond hard-wired device address pins A0 to A2.

### Device Address Word

Device address word (8-bit)								
	Device code (fixed)				Device address code			R/W code* <sup>1</sup>
64k	1	0	1	0	A2	A1	A0	R/W

Note: 1. R/W=“1” is read and R/W = “0” is write.

**Write Operations(WP=Low)**

**Byte Write: (Write operation during WP=Low status)**

A write operation requires an 8-bit device address word with R/W = "0". Then the EEPROM sends acknowledgment "0" at the ninth clock cycle. After these, the 64kbit EEPROM receives 2 sequence 8-bit memory address words. Upon receipt of this memory address, the EEPROM outputs acknowledgment "0" and receives a following 8-bit write data. After receipt of write data, the EEPROM outputs acknowledgment "0". If the EEPROM receives a stop condition, the EEPROM enters an internally-timed write cycle and terminates receipt of SCL, SDA inputs until completion of the write cycle. The EEPROM returns to a standby mode after completion of the write cycle.

**Byte Write Operation**

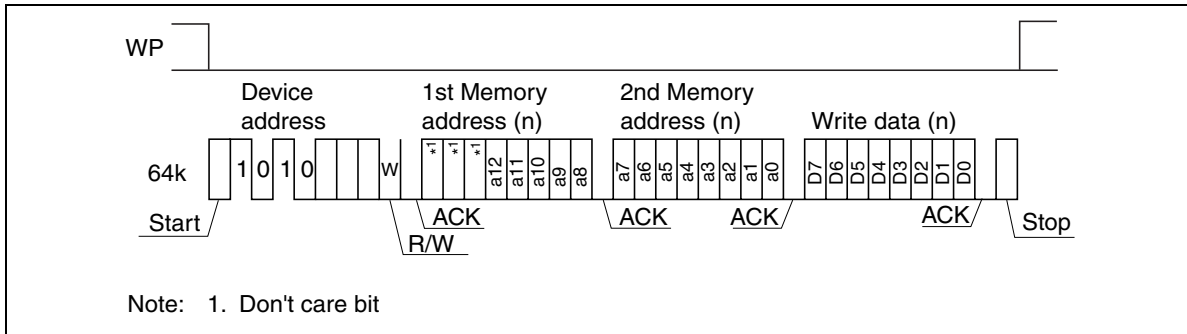

**Page Write:**

The EEPROM is capable of the page write operation which allows any number of bytes up to 32 bytes to be written in a single write cycle. The page write is the same sequence as the byte write except for inputting the more write data. The page write is initiated by a start condition, device address word, memory address(n) and write data (Dn) with every ninth bit acknowledgment. The EEPROM enters the page write operation if the EEPROM receives more write data (Dn+1) instead of receiving a stop condition. The a0 to a4 address bits are automatically incremented upon receiving write data (Dn+1). The EEPROM can continue to receive write data up to 32 bytes. If the a0 to a4 address bits reaches the last address of the page, the a0 to a4 address bits will roll over to the first address of the same page and previous write data will be overwritten. Upon receiving a stop condition, the EEPROM stops receiving write data and enters internally-timed write cycle.

**Page Write Operation**

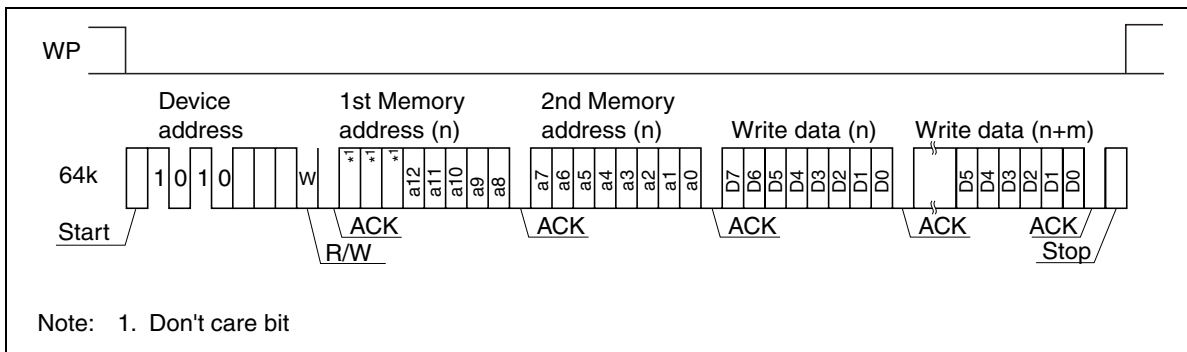

**Write Operations(WP=High)**

**Byte Write: (Write operation during WP=High status)**

A write operation requires an 8-bit device address word with R/W = "0". Then the EEPROM sends acknowledgment "0" at the ninth clock cycle. After these, the 64kbit EEPROM receives 2 sequence 8-bit memory address words.

Upon receipt of this memory address, the EEPROM outputs acknowledgment "0". After receipt of 8-bit write data, the EEPROM outputs acknowledgment "1"(NO ACK). Then the EEPROM write operations are not allowed.

**Byte Write Operation**

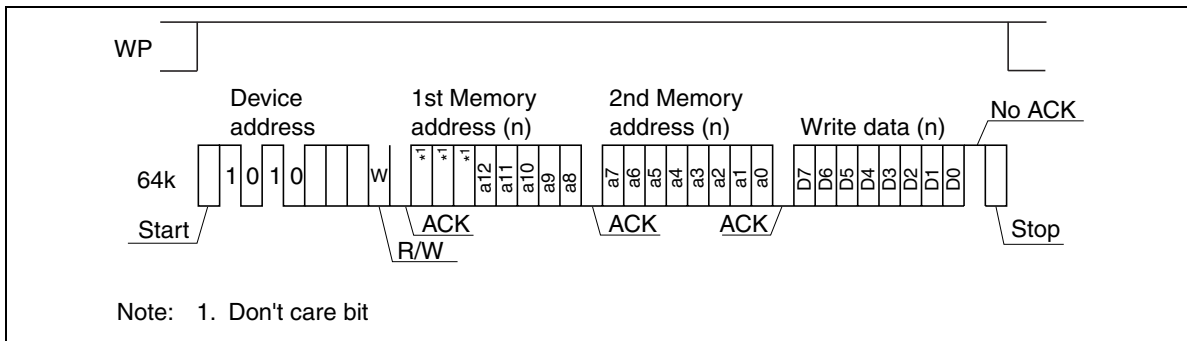

**Page Write:**

The page write is the same sequence as the byte write. The page write is initiated by a start condition, device address word and memory address(n) with every ninth bit acknowledgment "0". But after inputting write data(Dn) , the EEPROM outputs acknowledgment "1"(NO ACK). Then the EEPROM write operations are not allowed.

**Page Write Operation**

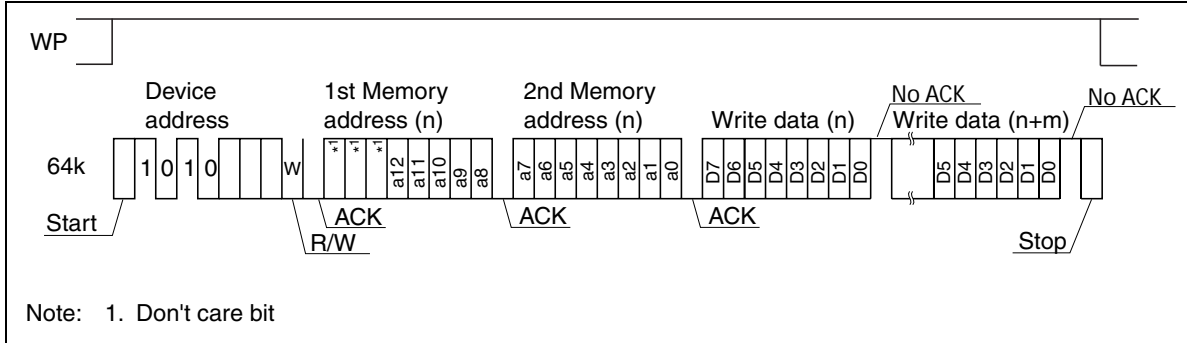

**Acknowledge Polling:**

Acknowledge polling feature is used to show if the EEPROM is in a internally-timed write cycle or not. This feature is initiated by the stop condition after inputting write data. This requires the 8-bit device address word following the start condition during a internally-timed write cycle. Acknowledge polling will operate when the R/W code = "0". Acknowledgment "1" (no acknowledgment) shows the EEPROM is in a internally-timed write cycle and acknowledgment "0" shows that the internally-timed write cycle has completed. See Write Cycle Polling using ACK.

**Write Cycle Polling Using ACK**

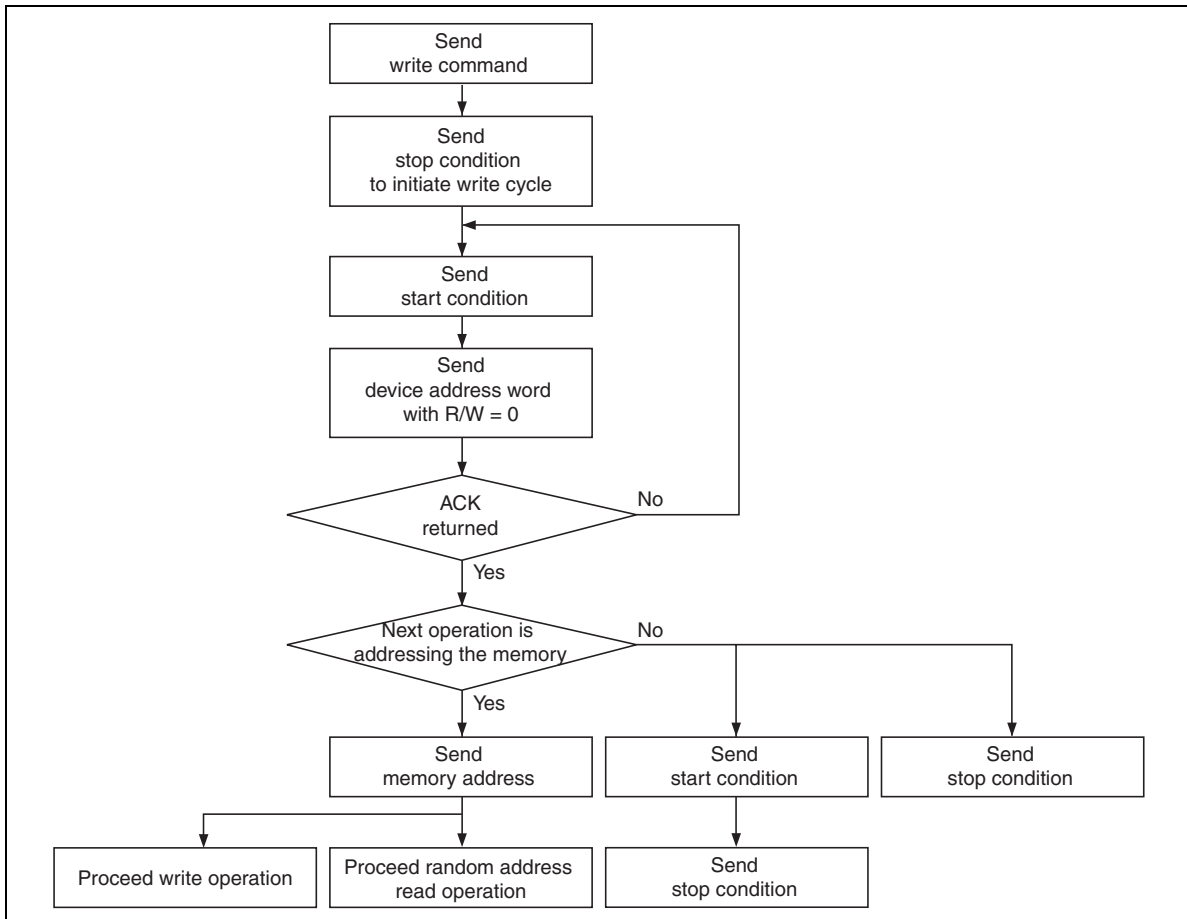

### Read Operation

There are three read operations: current address read, random read, and sequential read. Read operations are initiated the same way as write operations with the exception of R/W = "1".

#### Current Address Read:

The internal address counter maintains the last address accessed during the last read or write operation, with incremented by one. Current address read accesses the address kept by the internal address counter. After receiving a start condition and the device address word (R/W is "1"), the EEPROM outputs the 8-bit current address data from the most significant bit following acknowledgment "0". If the EEPROM receives acknowledgment "1" (no acknowledgment) and a following stop condition, the EEPROM stops the read operation and is turned to a standby state. In case the EEPROM has accessed the last address of the last page at previous read operation, the current address will roll over and returns to zero address. In case the EEPROM has accessed the last address of the page at previous write operation, the current address will roll over within page addressing and returns to the first address in the same page. The current address is valid while power is on. The current address after power on will be indefinite. The random read operation described below is necessary to define the memory address.

#### Current Address Read Operation

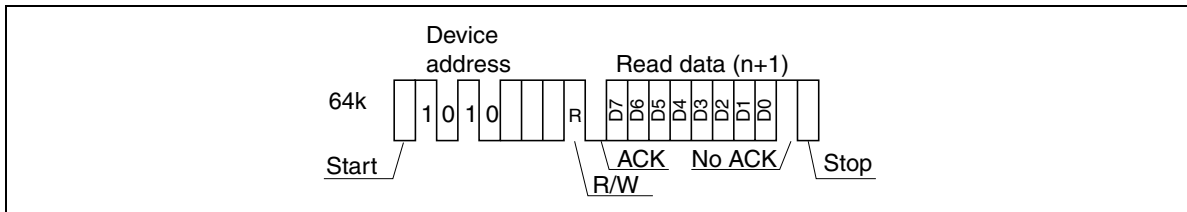

**Random Read:**

This is a read operation with defined read address. A random read requires a dummy write to set read address. The EEPROM receives a start condition, device address word (R/W=0) and memory address  $2 \times 8$ -bit sequentially. The EEPROM outputs acknowledgment "0" after receiving memory address then enters a current address read with receiving a start condition. The EEPROM outputs the read data of the address which was defined in the dummy write operation. After receiving acknowledgment "1"(no acknowledgment) and a following stop condition, the EEPROM stops the random read operation and returns to a standby state.

**Random Read Operation**

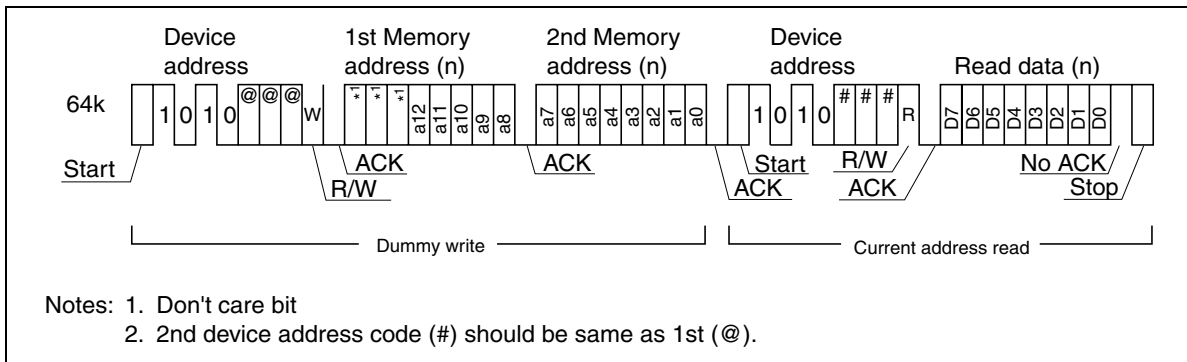

**Sequential Read:**

Sequential reads are initiated by either a current address read or a random read. If the EEPROM receives acknowledgment “0” after 8-bit read data, the read address is incremented and the next 8-bit read data are coming out. This operation can be continued as long as the EEPROM receives acknowledgment “0”. The address will roll over and returns address zero if it reaches the last address of the last page. The sequential read can be continued after roll over. The sequential read is terminated if the EEPROM receives acknowledgment “1” (no acknowledgment) and a following stop condition.

**Sequential Read Operation**

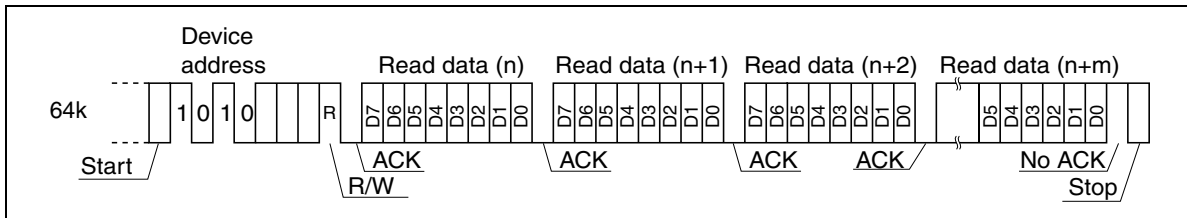

## Notes

### Data Protection at $V_{cc}$ On/Off

When  $V_{cc}$  is turned on or off, noise on the SCL and SDA inputs generated by external circuits (CPU, etc) may act as a trigger and turn the EEPROM to unintentional program mode. To prevent this unintentional programming, this EEPROM has a power on reset function. Be careful of the notices described below in order for the power on reset function to operate correctly.

- SCL and SDA should be fixed to  $V_{cc}$  or  $V_{ss}$  during  $V_{cc}$  on/off. Low to high or high to low transition during  $V_{cc}$  on/off may cause the trigger for the unintentional programming.
- $V_{cc}$  should be turned off after the EEPROM is placed in a standby state.
- $V_{cc}$  should be turned on from the ground level( $V_{ss}$ ) in order for the EEPROM not to enter the unintentional programming mode.
- $V_{cc}$  turn on rate should be longer than  $2 \mu\text{s}/V$ .

### Noise Suppression Time

This EEPROM have a noise suppression function at SCL and SDA inputs, that cut noise of width less than 50 ns. Be careful not to allow noise of width more than 50 ns.

# R1EX24064AxxS0A

## Package Dimensions

R1EX24064ASAS0A (PRSP0008DF-B / Previous Code: FP-8DBV)

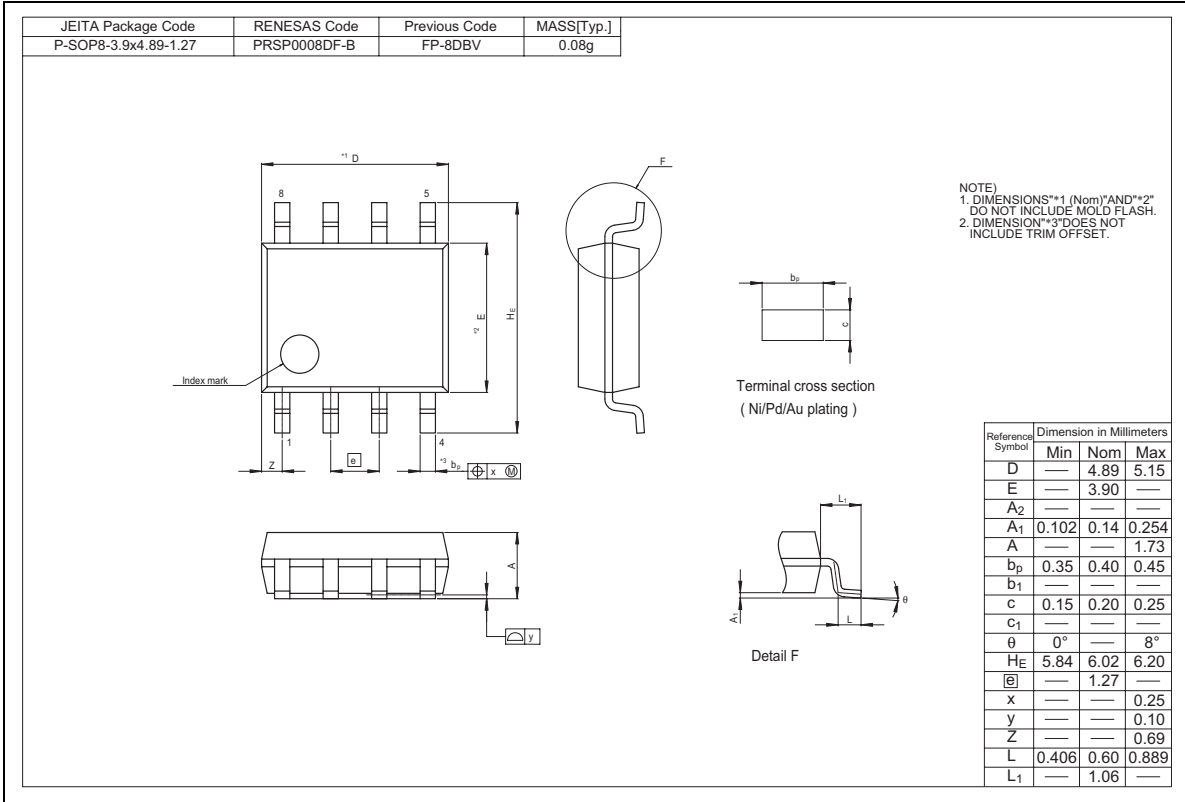

# R1EX24064AxxS0A

## R1EX24064ATAS0A (PTSP0008JC-B / Previous Code: TTP-8DAV)

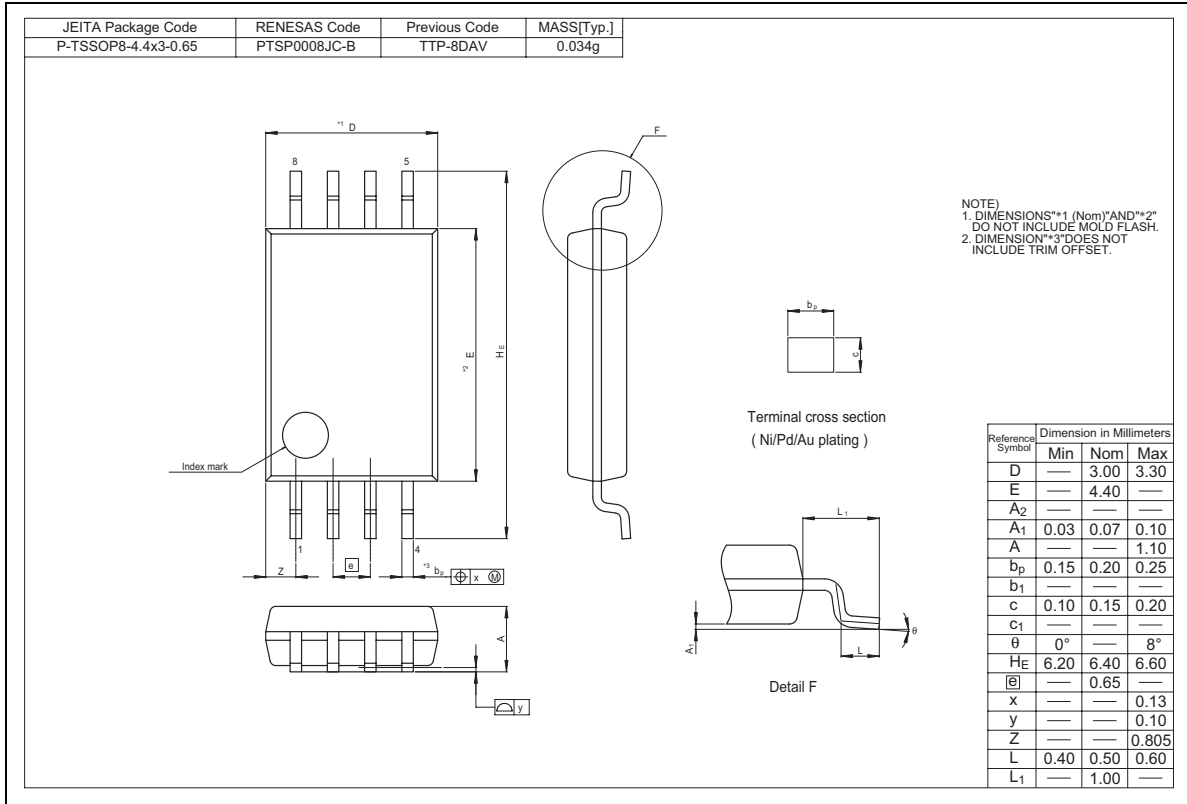

## Revision History

## R1EX24064AxxS0A Data Sheet

Rev.	Date	Contents of Modification	
		Page	Description
0.01	Nov. 05, 2007	—	Initial issue
1.00	April. 21, 2008	—	Deletion preliminary
1.01	Jan.13, 2009	P1	<p>Features</p> <p>Power dissipation Active(write) change 3.5mA to 3.0mA.                      Endurance cycles change 10<sup>6</sup> cycles to 1,000k cycles @ 25°C.                      Data retentions years change 10 years to 100 years @ 25°C.</p>
		P4	<p>DC characteristics</p> <p>Write Vcc current change 3.5 mA to 3.0 mA.                      Memory cell characteristics new is described.</p>
		P5	<p>AC characteristics</p> <p>Erase/Write endurance is deleted.                      Notes1. change Not 100% tested.                      Notes3 deleted.</p>
2.00	Oct.26, 2009	P8	<p>Addition of device address description</p> <p>These pins are internally pulled-down to Vss. The device reads these pins as Low if unconnected.</p> <p>Addition of write protect description</p> <p>The WP pin is internally pulled-down to Vss. Write operations for all memory array are allowed if unconnected.</p>
		P20	<p>Change of Vcc turn on description</p> <ul style="list-style-type: none"> <li>·Vcc turn on speed should be longer than 10 μs . to</li> <li>·Vcc turn on rate should be longer than 2 μs/V.</li> </ul>

Notes:

1. This document is provided for reference purposes only so that Renesas customers may select the appropriate Renesas products for their use. Renesas neither makes warranties or representations with respect to the accuracy or completeness of the information contained in this document nor grants any license to any intellectual property rights or any other rights of Renesas or any third party with respect to the information in this document.
2. Renesas shall have no liability for damages or infringement of any intellectual property or other rights arising out of the use of any information in this document, including, but not limited to, product data, diagrams, charts, programs, algorithms, and application circuit examples.
3. You should not use the products or the technology described in this document for the purpose of military applications such as the development of weapons of mass destruction or for the purpose of any other military use. When exporting the products or technology described herein, you should follow the applicable export control laws and regulations, and procedures required by such laws and regulations.
4. All information included in this document such as product data, diagrams, charts, programs, algorithms, and application circuit examples, is current as of the date this document is issued. Such information, however, is subject to change without any prior notice. Before purchasing or using any Renesas products listed in this document, please confirm the latest product information with a Renesas sales office. Also, please pay regular and careful attention to additional and different information to be disclosed by Renesas such as that disclosed through our website. (<http://www.renesas.com>)
5. Renesas has used reasonable care in compiling the information included in this document, but Renesas assumes no liability whatsoever for any damages incurred as a result of errors or omissions in the information included in this document.
6. When using or otherwise relying on the information in this document, you should evaluate the information in light of the total system before deciding about the applicability of such information to the intended application. Renesas makes no representations, warranties or guarantees regarding the suitability of its products for any particular application and specifically disclaims any liability arising out of the application and use of the information in this document or Renesas products.
7. With the exception of products specified by Renesas as suitable for automobile applications, Renesas products are not designed, manufactured or tested for applications or otherwise in systems the failure or malfunction of which may cause a direct threat to human life or create a risk of human injury or which require especially high quality and reliability such as safety systems, or equipment or systems for transportation and traffic, healthcare, combustion control, aerospace and aeronautics, nuclear power, or undersea communication transmission. If you are considering the use of our products for such purposes, please contact a Renesas sales office beforehand. Renesas shall have no liability for damages arising out of the uses set forth above.
8. Notwithstanding the preceding paragraph, you should not use Renesas products for the purposes listed below:
  - (1) artificial life support devices or systems
  - (2) surgical implantations
  - (3) healthcare intervention (e.g., excision, administration of medication, etc.)
  - (4) any other purposes that pose a direct threat to human lifeRenesas shall have no liability for damages arising out of the uses set forth in the above and purchasers who elect to use Renesas products in any of the foregoing applications shall indemnify and hold harmless Renesas Technology Corp., its affiliated companies and their officers, directors, and employees against any and all damages arising out of such applications.
9. You should use the products described herein within the range specified by Renesas, especially with respect to the maximum rating, operating supply voltage range, movement power voltage range, heat radiation characteristics, installation and other product characteristics. Renesas shall have no liability for malfunctions or damages arising out of the use of Renesas products beyond such specified ranges.
10. Although Renesas endeavors to improve the quality and reliability of its products, IC products have specific characteristics such as the occurrence of failure at a certain rate and malfunctions under certain use conditions. Please be sure to implement safety measures to guard against the possibility of physical injury, and injury or damage caused by fire in the event of the failure of a Renesas product, such as safety design for hardware and software including but not limited to redundancy, fire control and malfunction prevention, appropriate treatment for aging degradation or any other applicable measures. Among others, since the evaluation of microcomputer software alone is very difficult, please evaluate the safety of the final products or system manufactured by you.
11. In case Renesas products listed in this document are detached from the products to which the Renesas products are attached or affixed, the risk of accident such as swallowing by infants and small children is very high. You should implement safety measures so that Renesas products may not be easily detached from your products. Renesas shall have no liability for damages arising out of such detachment.
12. This document may not be reproduced or duplicated, in any form, in whole or in part, without prior written approval from Renesas.
13. Please contact a Renesas sales office if you have any questions regarding the information contained in this document, Renesas semiconductor products, or if you have any other inquiries.



**RENESAS SALES OFFICES**

<http://www.renesas.com>

Refer to "<http://www.renesas.com/en/network>" for the latest and detailed information.

**Renesas Technology America, Inc.**  
450 Holger Way, San Jose, CA 95134-1368, U.S.A  
Tel: <1> (408) 382-7500, Fax: <1> (408) 382-7501

**Renesas Technology Europe Limited**  
Dukes Meadow, Millboard Road, Bourne End, Buckinghamshire, SL8 5FH, U.K.  
Tel: <44> (1628) 585-100, Fax: <44> (1628) 585-900

**Renesas Technology (Shanghai) Co., Ltd.**  
Unit 204, 205, AZIACenter, No.1233 Lujiazui Ring Rd, Pudong District, Shanghai, China 200120  
Tel: <86> (21) 5877-1818, Fax: <86> (21) 6887-7858/7898

**Renesas Technology Hong Kong Ltd.**  
7th Floor, North Tower, World Finance Centre, Harbour City, Canton Road, Tsimshatsui, Kowloon, Hong Kong  
Tel: <852> 2265-6688, Fax: <852> 2377-3473

**Renesas Technology Taiwan Co., Ltd.**  
10th Floor, No.99, Fushing North Road, Taipei, Taiwan  
Tel: <886> (2) 2715-2888, Fax: <886> (2) 3518-3399

**Renesas Technology Singapore Pte. Ltd.**  
1 Harbour Front Avenue, #06-10, Keppel Bay Tower, Singapore 098632  
Tel: <65> 6213-0200, Fax: <65> 6278-8001

**Renesas Technology Korea Co., Ltd.**  
Kukje Center Bldg. 18th Fl., 191, 2-ka, Hangang-ro, Yongsan-ku, Seoul 140-702, Korea  
Tel: <82> (2) 796-3115, Fax: <82> (2) 796-2145

**Renesas Technology Malaysia Sdn. Bhd**  
Unit 906, Block B, Menara Amcorp, Amcorp Trade Centre, No.18, Jln Persiaran Barat, 46050 Petaling Jaya, Selangor Darul Ehsan, Malaysia  
Tel: <603> 7955-9390, Fax: <603> 7955-9510

## Looking for pricing, stock, or lifecycle information?

Click below to explore more details on WIN SOURCE:

- ⊖ [View R1EX24064ASAS0A#U0 on WIN SOURCE](#)
- ⊖ [Renesas Electronics America](#) Information

## Optimize Your Supply Chain with WIN SOURCE Solutions

- ✓ Global Sourcing Solution
- ✓ Obsolete Management
- ✓ Cost Control Management
- ✓ Shortage Management
- ✓ Alternative Solution
- ✓ Excess Inventory Management