



**THE DATASHEET OF
532L25DT19M2000**





FEATURES

- **Clipped Sine Wave Output**
- **Optional Voltage Control for Frequency Tuning [VCTCXO]**
- 5.0mmx3.2mm Surface Mount Package
- Frequency Range 10 – 40 MHz [Standard Frequencies List Shown Below]
- Fundamental Crystal Design
- Frequency Stability, several options to choose from $\pm 0.5\text{ppm} \sim \pm 2.5\text{ppm}$
- Operating Voltage, +2.8Vdc \sim +5.0Vdc
- Operating Temperature to -40°C to +85°C
- Tape & Reel Packaging, EIA-418
- **RoHS/Green Compliant (6/6)**

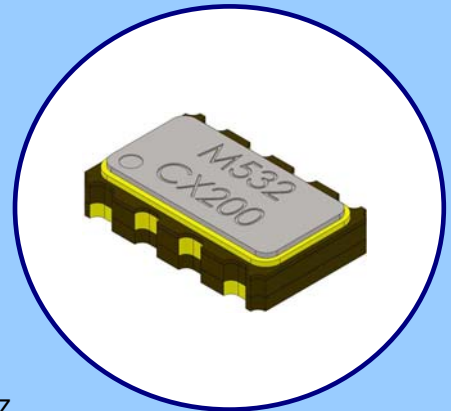

APPLICATIONS

The Model 532 Temperature Compensated Crystal Oscillator (TCXO) is a quartz based, clipped sine wave output, digital temperature compensated oscillator with optional frequency tuning, in a hermetically sealed ceramic package. M532 is suitable for wireless communications, broadband access, WLAN/WiMax/WIFI, portable equipment, test and measurement and mobile phone applications.

ORDERING INFORMATION

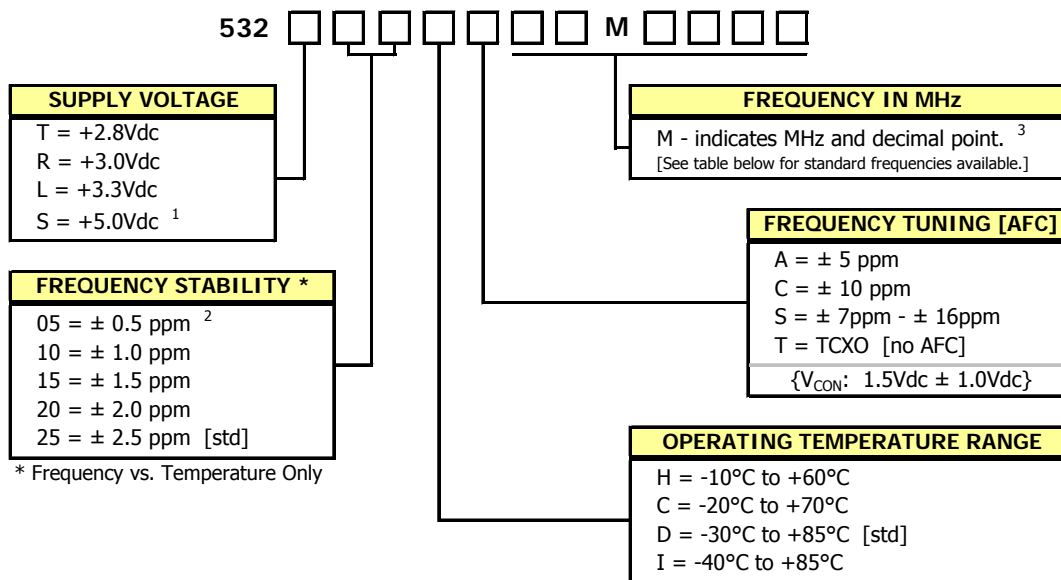

1] Limited availability. Please consult factory.
2] Only available with temperature range codes "H" and "C".
3] Frequency is recorded with two leading digits before the 'M' and 4 significant digits after the 'M' (including zeros).
[Ex. XXMXXXX (10M0000), XXMXXXX (16M3840)]

**Not all performance combinations and frequencies may be available.
Contact your local CTS Representative or CTS Customer Service for availability.**

M532 Standard Frequencies						
10.000 MHz	13.000 MHz	16.3676 MHz	16.384 MHz	19.680 MHz	25.000 MHz	36.000 MHz
12.000 MHz	14.400 MHz	16.367667 MHz	16.800 MHz	20.000 MHz	26.000 MHz	40.000 MHz
12.288 MHz	14.7456 MHz	16.368 MHz	19.200 MHz	24.000 MHz	27.000 MHz	
12.800 MHz	16.000 MHz	16.369 MHz	19.440 MHz	24.5535 MHz	30.000 MHz	

ELECTRICAL CHARACTERISTICS

PARAMETER	SYMBOL	CONDITIONS	MIN	TYP	MAX	UNIT
Maximum Supply Voltage	V _{CC}	-	-0.5	-	6.0	V
Maximum Control Voltage	V _C	-	-0.5	-	V _{CC}	V
Storage Temperature	T _{STG}	-	-40	-	85	°C
Frequency Range	f ₀	Std frequencies listed in Ordering Information	10	-	40	MHz
Frequency Stability	Δf/f ₀	Frequency vs. Temperature Only	0.5, 1.0, 1.5, 2.0, 2.5	-	-	± ppm
Frequency Stability vs. Initial Calibration	-	@25°C	-	-	1.0	± ppm
vs. Supply Voltage	-	±5% change	-	-	0.2	
vs. Load	-	±10% change	-	-	0.2	
vs. Reflow Shift	-	After 2 reflows	-	-	2.0	
vs. Aging	-	1st year	-	-	1.0	
		10 year	-	-	10.0	
Operating Temperature	T _A	-	-10	25	60	°C
Order Code 'H'			-20		70	
Order Code 'C'			-30		85	
Order Code 'I'			-40		85	
Supply Voltage	V _{CC}	±5%	2.66	2.8	2.94	V
Order Code 'T'			2.85	3.0	3.15	
Order Code 'R'			3.14	3.3	3.47	
Order Code 'S'		Consult factory for availability	4.75	5.0	5.25	
Supply Current	I _{CC}	10.00 MHz - 14.99 MHz 15.00 MHz - 25.99 MHz 26.00 MHz - 40.00 MHz	-	-	1.5	mA
			-	-	2.0	
			-	-	2.5	
Control Voltage	V _C	-	0.5	1.5	2.5	V
Frequency Tuning [VCTCXO Only]	-	V _C = 1.5V ±1.0V	5.0	-	-	± ppm
Order Code 'A'			10.0	-	-	
Order Code 'C'			7.0	-	16	
Order Code 'S'			-	-	-	
V _C Input Impedance	ZV _C	-	500	-	-	kOhm
Output Waveform	-	AC coupled Clipped Sinewave	-	-	-	-
Output Voltage Levels	V _O	-	0.8	-	-	Vp-p
Output Load	R _L // C _L	-	10 kOhm	//	10 pF	-
Start Up Time	T _S	-	-	-	2	ms
Phase Noise ¹	-	-	-	-	-	dBc/Hz

1. Phase Noise performance may vary based on output frequency. See example plot at 10 MHz below.

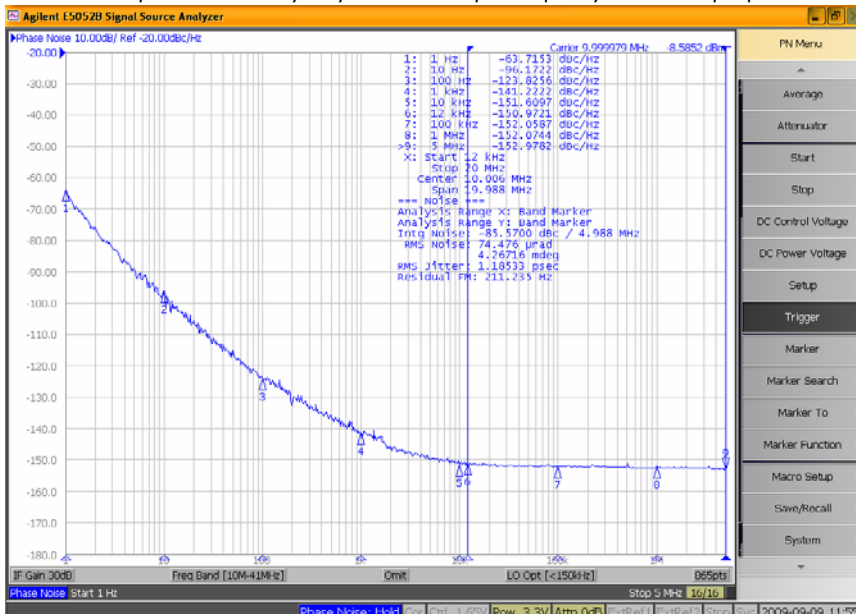

SINGLE SIDE BAND PHASE NOISE
(typical maximums @ 10 MHz)

Frequency Offset	Phase Noise (dBc/Hz)
10 Hz	-90
100 Hz	-115
1k Hz	-135
10k Hz	-148

MECHANICAL SPECIFICATIONS

PACKAGE DRAWING

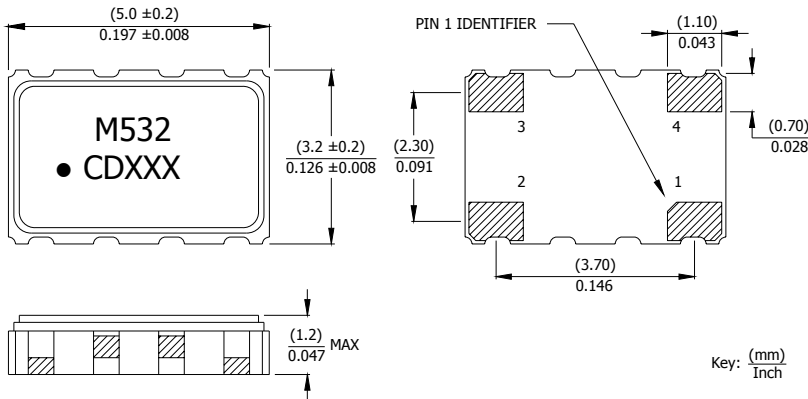

MARKING INFORMATION

1. M532 - CTS Model Series.
2. ● - Pin 1 identifier.
3. C - CTS identifier.
4. D - Date code. See Table II for codes.
5. XXX - Frequency code. See Table I for codes.

Complete CTS part number, frequency value and date code information must appear on reel and carton labels.

NOTES

1. DO NOT make connections to non-labeled pins. Castellation pins may have internal connections used in the manufacturing process.
2. Termination pads (e4); barrier plating is nickel (Ni) with gold (Au) flash plate.
3. Reflow conditions per JEDEC J-STD-020, 260°C maximum.

SUGGESTED SOLDER PAD GEOMETRY

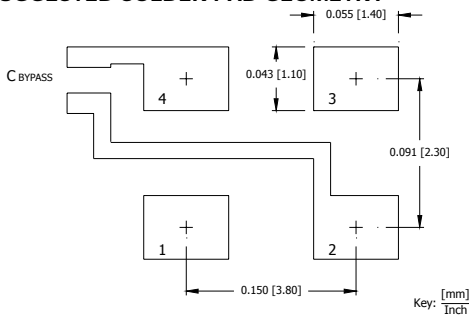

C_{BYPASS} should be ≥ 0.01 uF.

TABLE I – FREQUENCY CODING

FREQUENCY	MARKING CODE	FREQUENCY	MARKING CODE	FREQUENCY	MARKING CODE	FREQUENCY	MARKING CODE
10.000 MHz	100	16.000 MHz	160	19.440 MHz	194	26.000 MHz	260
10.240 MHz	102	16.367 MHz	16A	19.680 MHz	196	27.000 MHz	270
12.000 MHz	120	16.3676 MHz	16E	19.800 MHz	198	30.000 MHz	300
12.288 MHz	122	16.367667 MHz	16B	19.998 MHz	199	32.000 MHz	320
12.800 MHz	128	16.368 MHz	16C	20.000 MHz	200	32.512 MHz	325
13.000 MHz	130	16.369 MHz	16D	20.480 MHz	204	32.768 MHz	327
13.500 MHz	135	16.384 MHz	163	21.000 MHz	210	36.000 MHz	360
14.000 MHz	140	16.800 MHz	168	24.000 MHz	240	38.880 MHz	388
14.400 MHz	144	18.000 MHz	180	24.5535 MHz	24B	40.000 MHz	400
14.7456 MHz	147	18.432 MHz	184	24.576 MHz	24C		
15.360 MHz	153	19.200 MHz	192	25.000 MHz	250		

Not all frequencies listed may be available for this design.

TABLE II – DATE CODE

YEAR		MONTH					JAN	FEB	MAR	APR	MAY	JUN	JUL	AUG	SEP	OCT	NOV	DEC
		2001	2005	2009	2013	2017												
2001	2005	2009	2013	2017	A	B	C	D	E	F	G	H	J	K	L	M		
2002	2006	2010	2014	2018	N	P	Q	R	S	T	U	V	W	X	Y	Z		
2003	2007	2011	2015	2019	a	b	c	d	e	f	g	h	j	k	l	m		
2004	2008	2012	2016	2020	n	p	q	r	s	t	u	v	w	x	y	z		

TEST CIRCUIT – RL//CL LOAD

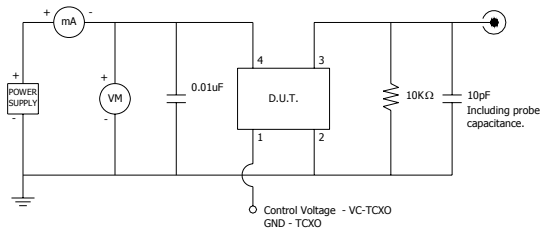

D.U.T. PIN ASSIGNMENTS

PIN	SYMBOL	DESCRIPTION
1	V _C	Control Voltage – VCTCXO (Note 1) GND - TCXO
2	GND	Circuit & Package Ground
3	Output	Clipped Sine Wave Output
4	V _{CC}	Supply Voltage

NOTES

1. Connect to ground for TCXO (no AFC) option.

PACKAGING INFORMATION

Device quantity is 1,000 pieces per 180mm reel.

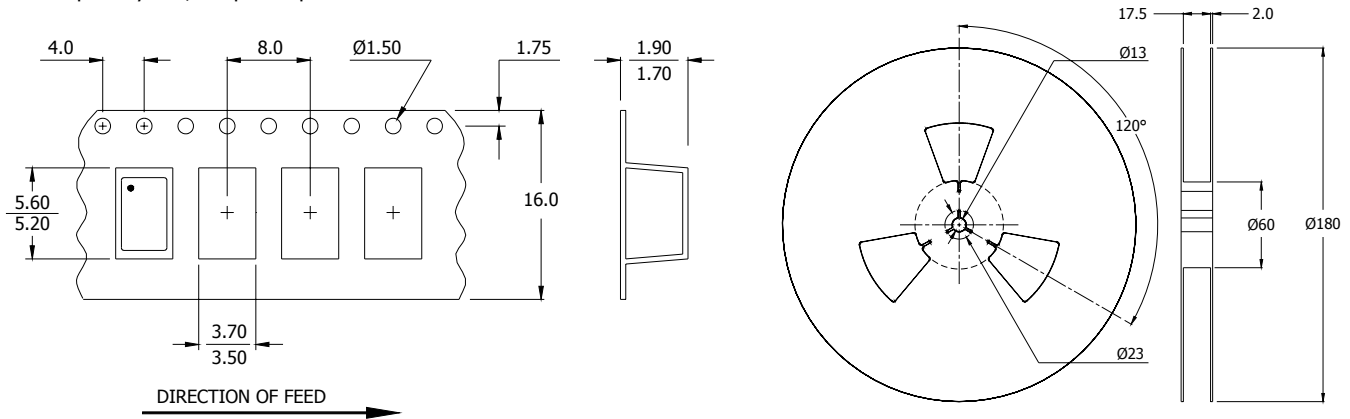

Dimensions in Millimeters

Looking for pricing, stock, or lifecycle information?

Click below to explore more details on WIN SOURCE:

- ⊖ [View 532L25DT19M2000 on WIN SOURCE](#)
- ⊖ [CTS-Frequency Controls Information](#)

Optimize Your Supply Chain with WIN SOURCE Solutions

- ✓ Global Sourcing Solution
- ✓ Obsolete Management
- ✓ Cost Control Management
- ✓ Shortage Management
- ✓ Alternative Solution
- ✓ Excess Inventory Management