

適合金めっきFPC推奨寸法
 APPLICABLE FPC OF GOLD
 PLATING RECOMMENDED DIMENSION
 仕上がり厚さ : 0.3±0.05
 THICKNESS: 0.3±0.05/-0.05

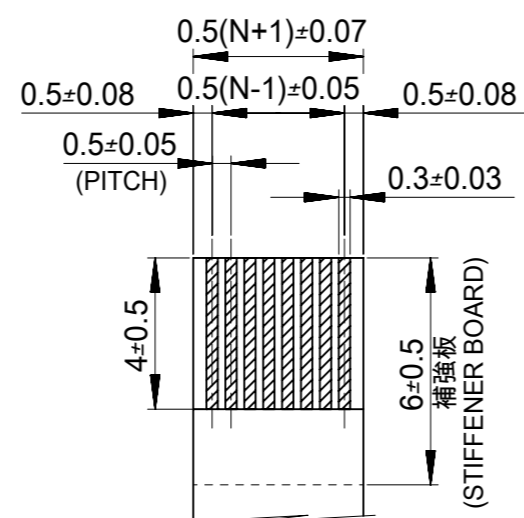

適合金めっきFFC推奨寸法
 APPLICABLE FFC OF GOLD
 PLATING RECOMMENDED DIMENSION
 仕上がり厚さ : 0.3±0.05
 THICKNESS: 0.3±0.05/-0.05

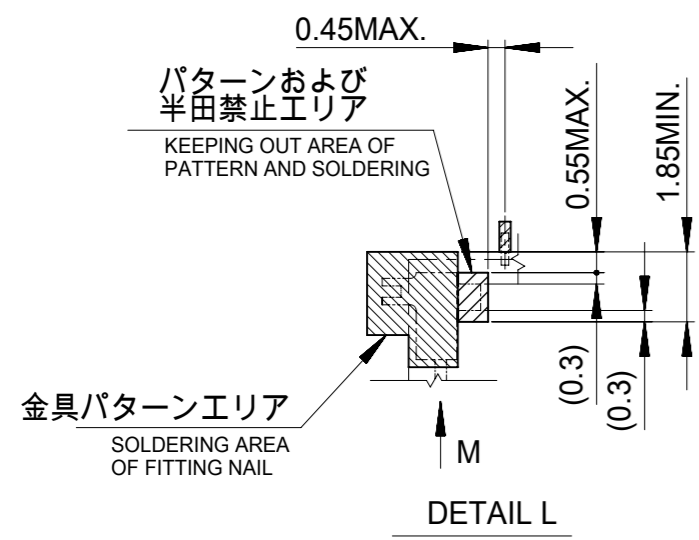

DETAIL L

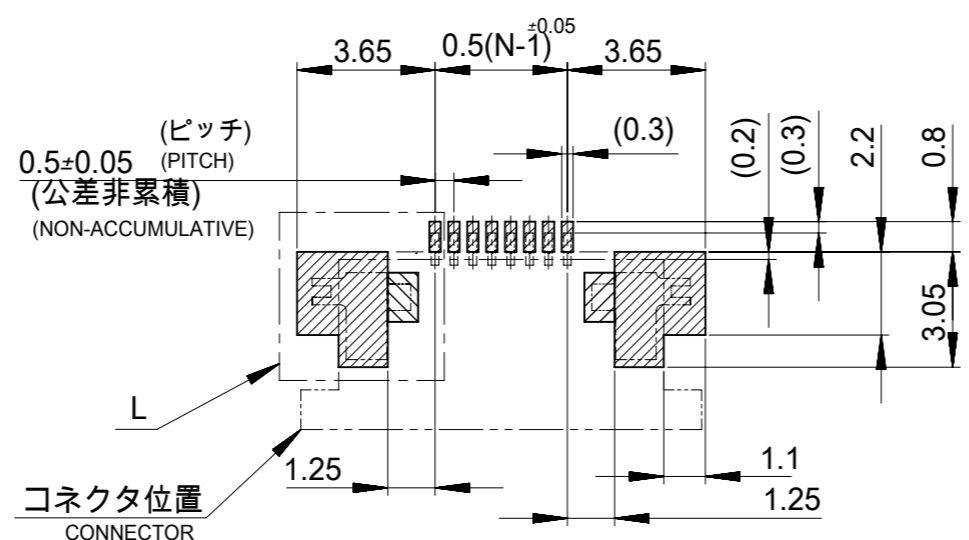

コネクタ位置
 CONNECTOR POSITION

参考基板レイアウト
 (マウント面)
 RECOMMENDED P.C.BOARD
 PATTERN DIMENSION (REF.)
 (MOUNTING SIDE)

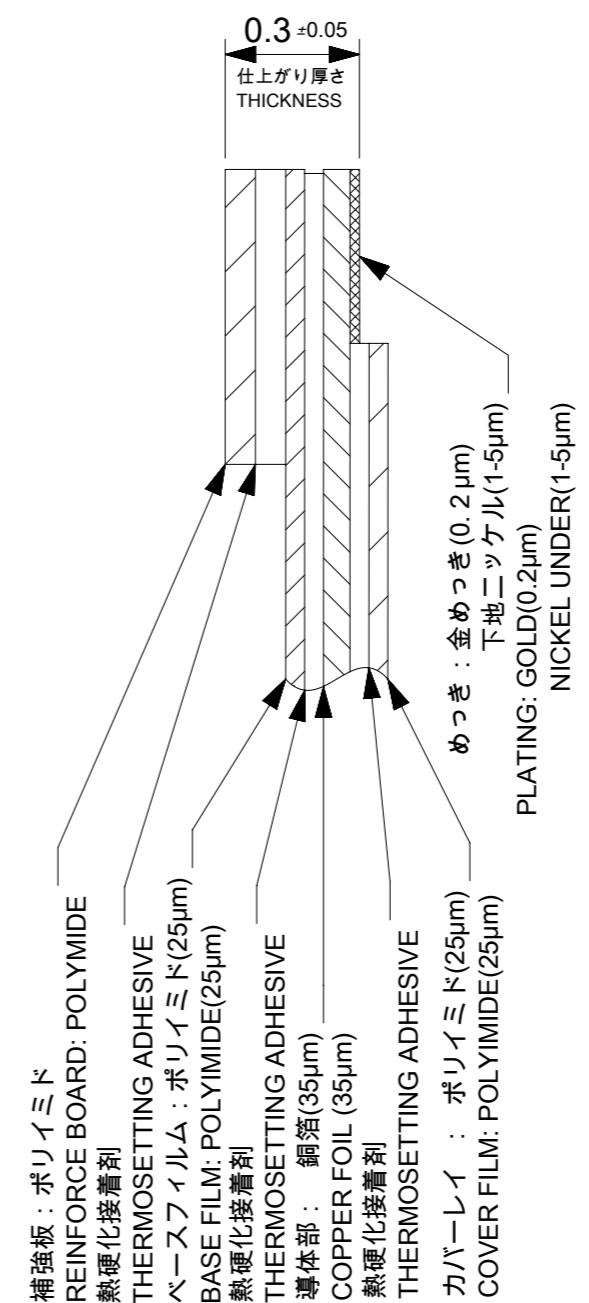

FPC構成推奨仕様
 STRUCTURE OF FPC

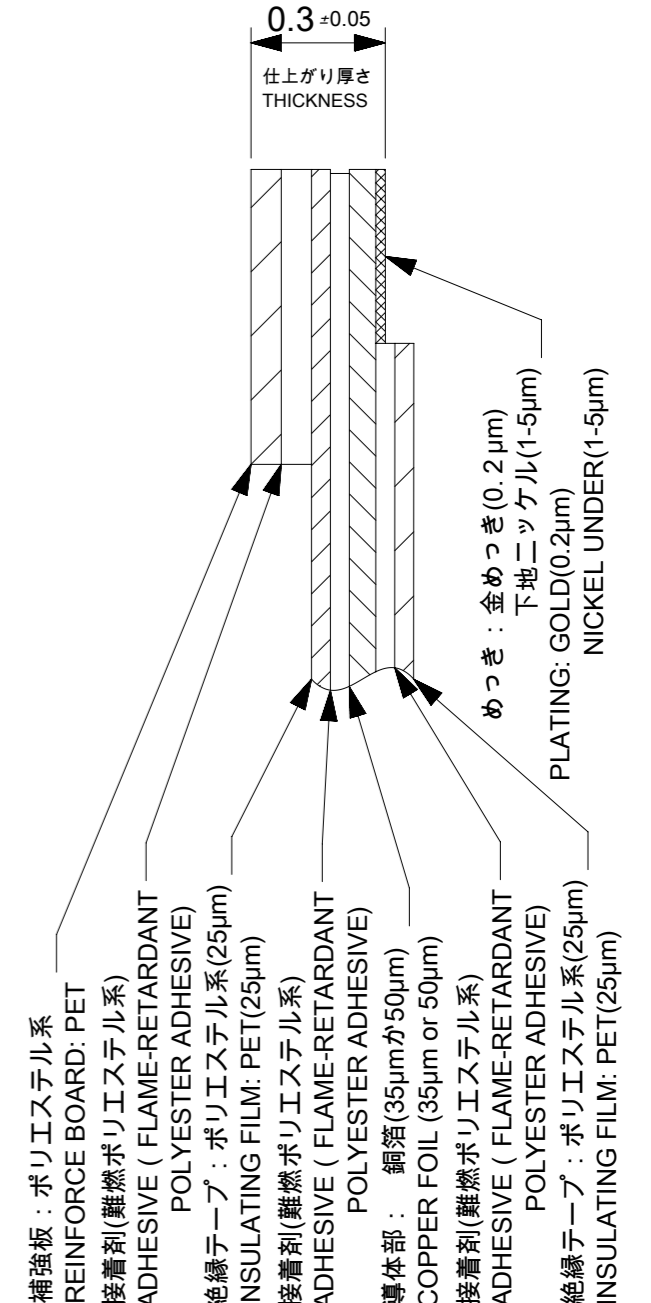

FFC構成推奨仕様
 STRUCTURE OF FFC

FPCについて
 打ち抜き方向は導体側から補強板を推奨いたします。
 補強フィルム材質はポリイミドを推奨いたします。
 接着剤は熱効果接着剤を推奨致します。

ABOUT FPC :
 RECOMMENDED PUNCHER DIRECTION : FROM CONDUCTOR SIDE TO STIFFNER BOARD SIDE.
 RECOMMENDED MATERIAL :
 STIFFNER FILM : POLYIMIDE
 BONDING AGENT : THERMOSETTING BONDING AGENT

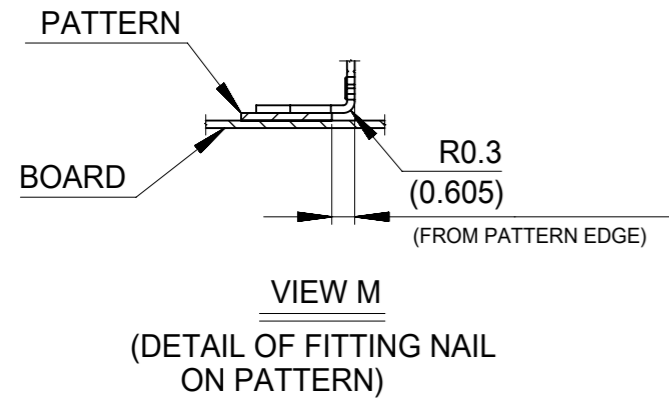

VIEW M
 (DETAIL OF FITTING NAIL
 ON PATTERN)

GENERAL TOLERANCES (UNLESS SPECIFIED)	
10 UNDER	± 0.2
10 OVER 30 UNDER	± 0.25
30 OVER	± 0.3
ANGULAR	± 3 °
DRAFT WHERE APPLICABLE MUST REMAIN WITHIN DIMENSIONS	

THIS DRAWING CONTAINS INFORMATION THAT IS PROPRIETARY TO MOLEX ELECTRONIC TECHNOLOGIES, LLC AND SHOULD NOT BE USED WITHOUT WRITTEN PERMISSION		CURRENT REV DESC:		molex	
DIMENSION UNITS	SCALE				
mm	5:1			0.5 FPC CONN.ZIF FOR SMT R/A (BOTTOM CONTACT) GOLD PLATING	
GENERAL TOLERANCES (UNLESS SPECIFIED)		EC NO: 600082		DOCUMENT NUMBER	
ANGULAR TOL	± 3.0 °	DRWN: YCHEN128 2018/03/02		SD-52437-019	
4 PLACES	± 0.2	CHK'D: KTAKAHASHI 2018/03/14		DOC TYPE DOC PART REVISION	
3 PLACES	± 0.25	APPR: NUKITA 2018/03/14		PSD 001 F	
2 PLACES	± 0.3	INITIAL REVISION:		MATERIAL NUMBER	
1 PLACE	±	DRWN: MUMEDA 2004/12/20		CUSTOMER	
0 PLACES	±	APPR: NUKITA 2004/12/24		GENERAL MARKET	
DRAFT WHERE APPLICABLE MUST REMAIN WITHIN DIMENSIONS		THIRD ANGLE PROJECTION	DRAWING	SERIES	SHEET NUMBER
		⊕	A3-SIZE	52437	2 OF 2

注記 NOTES

- 製品番号52437-**29の梱包状態はアクチュエータがロックした状態とする。
製品の詳細寸法については図面SD-52437-019を参照下さい。
IN THE PACKAGE, ACTUATOR OF PART NO. 52437-**29 SHOULD BE LOCKED RE DETAILED DIMENSIONS, SEE SD-52437-019.
- 梱包数量：1000個/リール
NUMBER OF CONNECTORS:1000PCS/REEL
- リードテープ長さ LEAD TAPE LENGTH

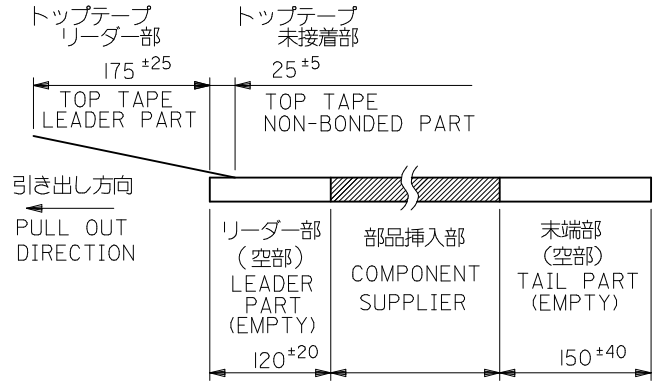

- トップテープの剥離強度：(剥離方向は下図参照)
0.1N ~ 1.3N {10gf ~ 130gf} 尚、本規格値は、出荷時に適用。
(但し、輸送時に剥離が発生しない事。)
PEELING OFF FORCE OF TOP TAPE
0.1N ~ 1.3N {10gf ~ 130gf} (PEELING DIRECTION AS SHOWN IN FOLLOWING FIG.)
THIS REQUIREMENT SHOULD BE APPLIED AT SHIPMENT
PEEL OFF SHOULD NOT BE ALLOWED,
DURING TRANSPORTATION

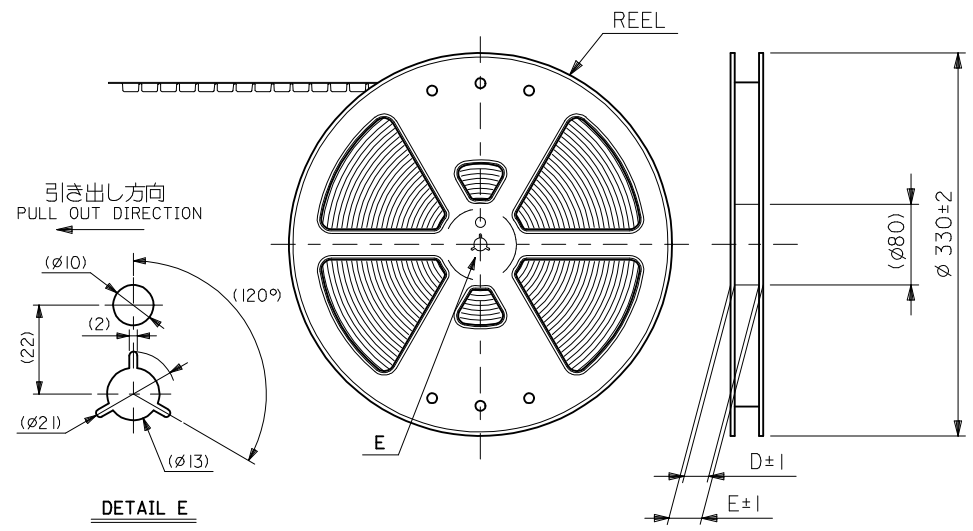
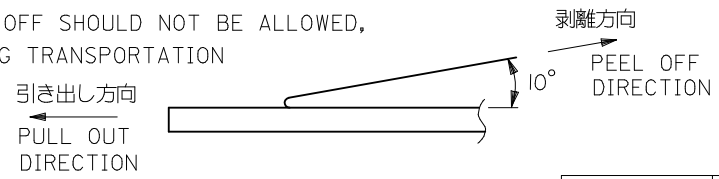

5. 材料 (MATERIAL)
 キャリアテープ (CARRIER TAPE) : ポリプロピレン (POLYPROPYLENE)
 トップテープ (TOP TAPE) : PET, PE, PEF
 リール (REEL) : ポリスチレン (PS) <リサイクル材を含む>
 POLYSTYREN (PS) <RECYCLE MATERIAL CONTAINED>

6. 本製品は 52437-**91 の鉛フリー品である。
 THIS PRODUCT IS LEAD FREE OF 52437-**91.

REVISED EC NO: J2014-0114 2013/07/22 DRWN: INOUE01 2013/07/29 CHKD: HIJIMA 2013/07/29 APPR: YNOGAWA 2013/07/29	DESCRIPTION REV	GENERAL TOLERANCES (UNLESS SPECIFIED)		DIMENSION STYLE MM ONLY		SCALE ---	DESIGN UNITS METRIC	MODEL NO.	52437-**71
		10 UNDER	± 0.2	DRAWN BY M.UMEDA	DATE 2004-12/08	TITLE 0.5 FPC CONN. ZIF SMT RA WITH TAPE EMBSTP PKG -LEAD FREE-			
		10 OVER 30 UNDER	± 0.25	CHECKED BY K.TOYODA	DATE 2004-12/08				
		30 OVER	± 0.3	APPROVED BY N.UKITA	DATE 2004-12/08				
ANGULAR ± 3 °		DRAFT WHERE APPLICABLE MUST REMAIN WITHIN DIMENSIONS		MATERIAL NO. SEE CHART		DOCUMENT NO. SD-52437-020		SHEET NO. 1 OF 3	
THIS DRAWING CONTAINS INFORMATION THAT IS PROPRIETARY TO MOLEX INCORPORATED AND SHOULD NOT BE USED WITHOUT WRITTEN PERMISSION									

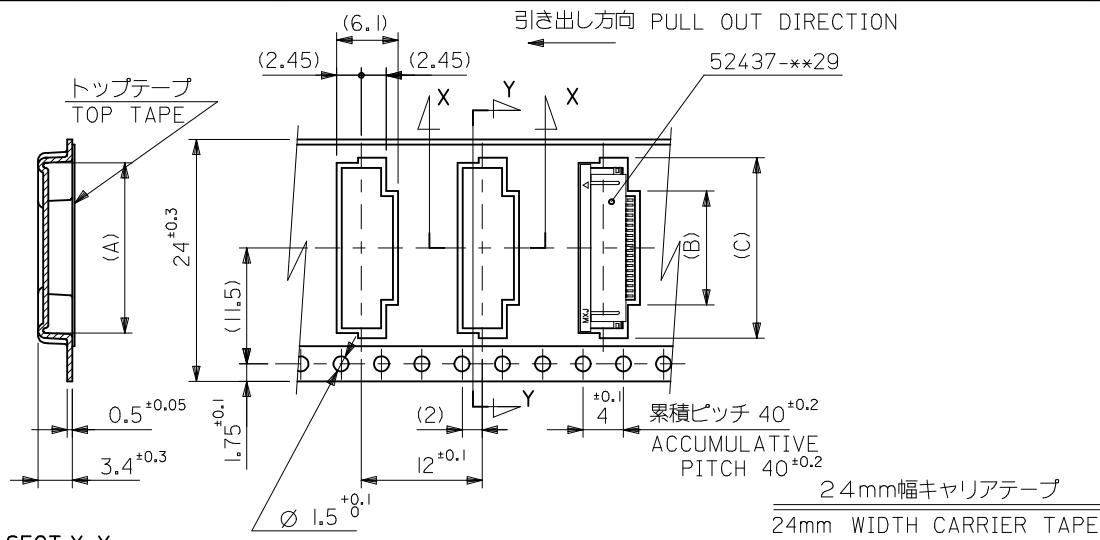

SECT.Y-Y

24mm幅キャリアテープ
24mm WIDTH CARRIER TAPE

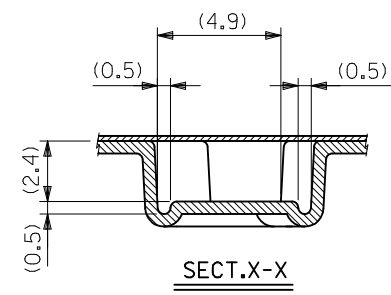

SECT.X-X

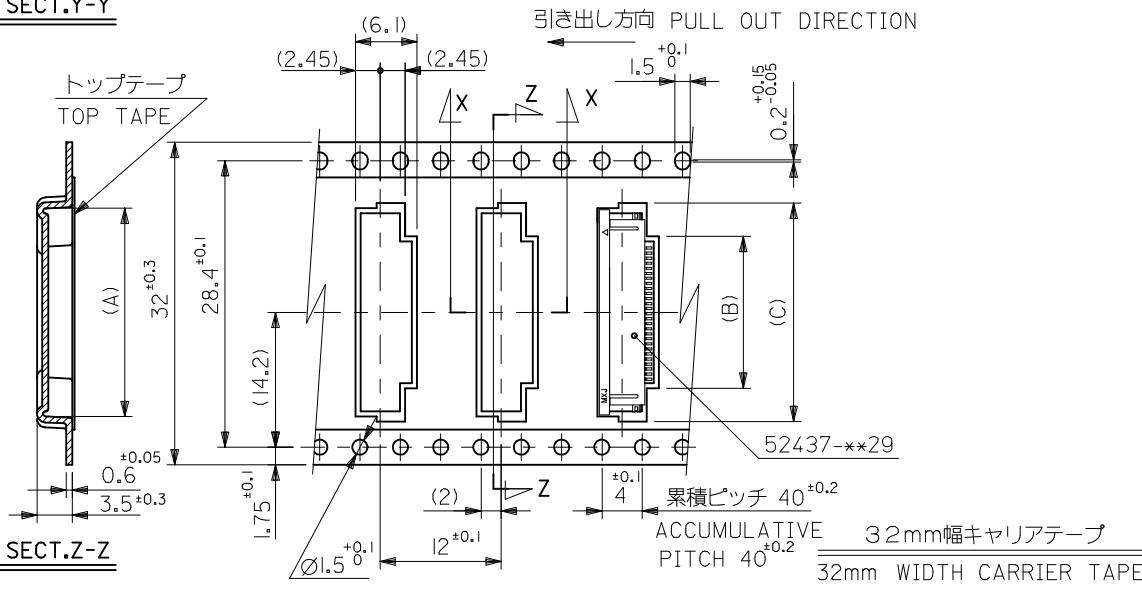

SECT.Z-Z

32mm幅キャリアテープ
32mm WIDTH CARRIER TAPE

32	37.4	33.4	22.4	15.8	21.4	52437-2971	29
			21.9	15.3	20.9	52437-2871	28
			21.4	14.8	20.4	52437-2771	27
			20.9	14.3	19.9	52437-2671	26
			20.4	13.8	19.4	52437-2571	25
			19.9	13.3	18.9	52437-2471	24
			19.4	12.8	18.4	52437-2371	23
18.9	12.3	17.9	52437-2271	22			
24	29.4	25.4	18.4	11.8	17.4	52437-2171	21
キャリアテープ幅 CARRIER TAPE WIDTH	E	D	(C)	(B)	(A)	MATERIAL NO.	極数 CIRCUIT
						MODEL NO.	52437-**-71

REVISED EC NO.: J2014-0114 2013/07/22 DRWN: INOUE01 2013/07/29 CHK: H I J I M A 2013/07/29 APPR: YNOGAWA 2013/07/29	GENERAL TOLERANCES (UNLESS SPECIFIED)		DIMENSION STYLE	SCALE	DESIGN UNITS	TITLE 0.5 FPC CONN. ZIF SMT RA WITH TAPE EMBSTP PKG -LEAD FREE- molex DOCUMENT NO. SD-52437-020 SHEET NO. 2 OF 3
	10 UNDER ±0.2		MM ONLY	---	METRIC	
	10 OVER 30 UNDER ±0.25		DRAWN BY DATE	THIRD ANGLE PROJECTION		
	30 OVER ±0.3		M. UMEDA 2004/12/08			
D	ANGULAR ±3 °		CHECKED BY DATE			
	DRAFT WHERE APPLICABLE MUST REMAIN WITHIN DIMENSIONS		K. TOYODA 2004/12/08			
			APPROVED BY DATE			
			N. UKITA 2004/12/08			
			MATERIAL NO.			
			SEE CHART			
			SIZE			
			A3	THIS DRAWING CONTAINS INFORMATION THAT IS PROPRIETARY TO MOLEX INCORPORATED AND SHOULD NOT BE USED WITHOUT WRITTEN PERMISSION		

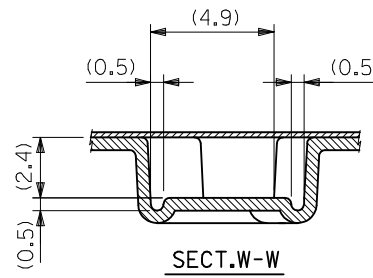
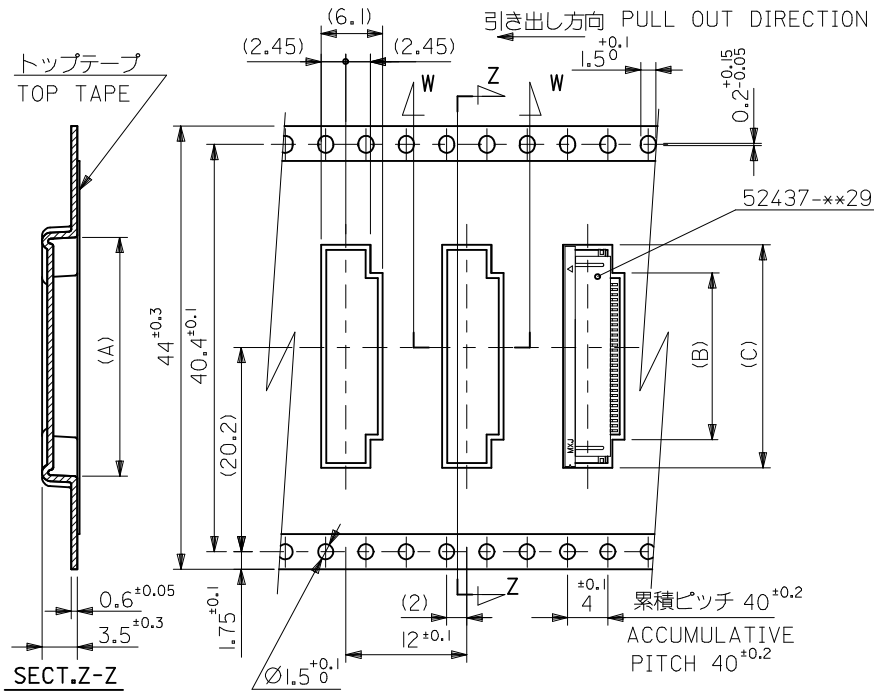

44mm幅キャリアテープ
44mm WIDTH CARRIER TAPE

44	49.4	45.4	22.9	16.3	21.9	52437-3071	30
キャリアテープ幅 CARRIER TAPE WIDTH	E	D	(C)	(B)	(A)	MATERIAL NO.	極数 CIRCUIT
						MODEL NO.	25437-**-71

REVISED EC NO: J2014-0114 DRWN: INOUE01 2013/07/29 CHKD: HIJIMA 2013/07/29 APPR: YNOGAWA 2013/07/29	GENERAL TOLERANCES (UNLESS SPECIFIED)		DIMENSION STYLE MM ONLY		SCALE ---	DESIGN UNITS METRIC	THIRD ANGLE PROJECTION	
	10 UNDER	±0.2	DRAWN BY M.UMEDA	DATE 2004/12/08	TITLE 0.5 FPC CONN. ZIF SMT RA WITH TAPE EMBSTP PKG -LEAD FREE-			
	10 OVER 30 UNDER	±0.25	CHECKED BY K.TOYODA	DATE 2004/12/08	molex DOCUMENT NO. SD-52437-020 SHEET NO. 3 OF 3			
	30 OVER	±0.3	APPROVED BY N.UKITA	DATE 2004/12/08				
	ANGULAR ±3 °	DRAFT WHERE APPLICABLE MUST REMAIN WITHIN DIMENSIONS		MATERIAL NO. SEE CHART		THIS DRAWING CONTAINS INFORMATION THAT IS PROPRIETARY TO MOLEX INCORPORATED AND SHOULD NOT BE USED WITHOUT WRITTEN PERMISSION		

Looking for pricing, stock, or lifecycle information?

Click below to explore more details on WIN SOURCE:

 [View 524372471 on WIN SOURCE](#)

 [Molex, LLC Information](#)

Optimize Your Supply Chain with WIN SOURCE Solutions

-  Global Sourcing Solution
-  Obsolete Management
-  Cost Control Management
-  Shortage Management
-  Alternative Solution
-  Excess Inventory Management