



**THE DATASHEET OF
PVZ3G103C01R00**





SPECIFICATION FOR SUPPLIED PRODUCT

TRIMMER POTENTIOMETER / PVZ3G□□□C01 SERIES

-CONTENTS-

1. SCOPE
2. MURATA PART NUMBER
3. OUTLINE DIMENSIONS AND MARKINGS
4. CHARACTERISTICS
 - 4.1 Electrical Characteristics
 - 4.2 Mechanical Characteristics
 - 4.3 Environmental Characteristics
 - 4.4 Other Characteristics
5. TEST METHOD
 - 5.1 Contact Resistance Variation (CRV)
 - 5.2 Temperature Coefficient of Resistance
 - 5.3 Permitted Force of Driver Plate
 - 5.4 Soldering Strength
 - 5.5 High Temperature Exposure
 - 5.6 Humidity Exposure
 - 5.7 Load Life
 - 5.8 Humidity Load Life
 - 5.9 Temperature Cycle
 - 5.10 Rotational Life
 - 5.11 Vibration
 - 5.12 Resistance to Soldering Heat
 - 5.13 Solderability
6. CAUTION
7. CAUTION FOR USING
 - 7.1 Mounting the product
 - 7.2 Soldering
 - 7.3 Cleaning
 - 7.4 Adjusting
 - 7.5 Operating Environmental Conditions
 - 7.6 Storage Conditions
 - 7.7 Circuit Design Guide
8. NOTICE
9. OUTLINE DIMENSIONS
10. TAPING SPECIFICATIONS
 - 10.1 Plastic Tape Dimensions
 - 10.2 Reel Dimensions
11. PART NUMBERS CROSS REFERENCE TABLE

1. Scope

This specification defines the characteristics of Murata made Trimmer Potentiometer PVZ3G□□□C01 series with carbon material of the resistive element.

2. Murata Part Number

PVZ3G□□□C01B00 Bulk : 1000pcs./bag
 PVZ3G□□□C01R00 Taping (Standard) : 2500pcs./reel
 PVZ3G□□□C01R02 Taping (Option) : 2500pcs./reel

Note 1) □□□: Resistance code

Resistance	Code	Resistance	Code	Resistance	Code	Resistance	Code	Resistance	Code	Resistance	Code
1k ohm	102	1.5k ohm	152	220 ohm	221	330 ohm	331	470 ohm	471	680 ohm	681
10k ohm	103	15k ohm	153	2.2k ohm	222	3.3k ohm	332	4.7k ohm	472	6.8k ohm	682
100k ohm	104	150k ohm	154	22k ohm	223	33k ohm	333	47k ohm	473	68k ohm	683
1M ohm	105	1.5M ohm	155	220k ohm	224	330k ohm	334	470k ohm	474	680k ohm	684
				2.2M ohm	225						

Note 2) Taping direction: See 10. Taping Specifications.

Note 3) Please fill in your part number on the cross-reference table.

3. Outline Dimensions and Markings

Please see 9. Outline Dimensions.

4. Characteristics

4.1 Electrical characteristics

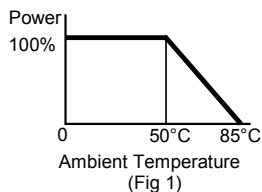
ITEM	SPECIFICATION	TEST METHOD
Standard Resistance Range	220 ohm to 2.2M ohm	-
Standard Resistance Tolerance	±30% of nominal total resistance value	-
Taper	B (Linear) • 50% position of effective rotational angle - 40 to 60% • Jump or reverse (except extreme end) - 5% max. • Jump or reverse (at the extreme end of #1 or #3) - 5% max.	-
Power Rating	50°C – 1/10W 85°C - 0W *In case that the ambient temperature exceed 50°C, the derating curve is as Fig 1. However, in case of partial load, power rating reduces in proportion to the rotational angle of wiper.	
Voltage Rating	$E=(P \cdot R)^{1/2}$ E: Voltage rating (V) P: Power rating (W) R: Nominal total resistance value (ohm) *However, in case that voltage rating exceed max. working voltage, the max. working voltage should be applied as voltage rating.	-
Max. Working Voltage	50Vdc	-
Operating Temperature Range	-25°C to +85°C	-
Residual Resistance	220 ohm ≤ R < 470 ohm : 10 ohm max. of nominal total resistance value 470 ohm ≤ R ≤ 2.2M ohm: 2% max. of nominal total resistance value	-
Contact Resistance Variation	5% max. of nominal total resistance value	5.1
Temperature Coefficient of Resistance	±500ppm/°C max.	5.2

4.2 Mechanical Characteristics

ITEM	SPECIFICATION	TEST METHOD
Effective Rotational Angle	230°±10° max.	-
Rotational Torque	1.0 to 19.6mN·m (Ref; 10 to 200gf·cm)	-
Permitted Force to Driver Plate	No mechanical damages and breaks. Rotational torque: 1.0 to 14.7mN·m (Ref; 10 to 150gf·cm)	5.3
Soldering Strength	No electrode peeling	5.4

4.3 Environmental Characteristics

ITEM	SPECIFICATION	TEST METHOD
High Temperature Exposure	Total resistance change 220 ohm≤R≤100k ohm : +2/-10% max. 100k ohm<R≤2.2M ohm: +2/-15% max. CCR (Note 4): 5% max. of nominal total resistance value	5.5
Humidity Exposure	Total resistance change: +10/-2% max. CCR (Note 4): 5% max. of nominal total resistance value	5.6
Load Life	Total resistance change 220 ohm≤R≤100k ohm : +2/-10% max. 100k ohm<R ≤2.2M ohm: +2/-15% max. CCR (Note 4): 5% max. of nominal total resistance value	5.7
Humidity Load Life	Total resistance change: ±10% max. CCR (Note 4): 5% max. of nominal total resistance value	5.8
Temperature Cycling	Total resistance change: ±5% max. CCR (Note 4): 5% max. of nominal total resistance value	5.9
Rotational Life	Total resistance change: ±10% max. Rotational torque: 0.5 to 19.6mN·m (Ref; 5 to 200gf.cm)	5.10
Vibration	SS (Note 5): ±2.5% max.	5.11
Soldering Heat Resistance	Total resistance change: ±5% max. CCR (Note 4): 5% max. of nominal total resistance value	5.12.1
	Total resistance change 220 ohm≤R≤100k ohm : 0/-15% max. 100k ohm<R ≤2.2M ohm: -5/-20% max. CCR (Note 4): 5% max. of nominal total resistance value	5.12.2

(Note 4)

$$\text{Concentrated Contact Resistance} = \frac{(R_{12}+R_{23}) - R_{13}}{2 \times R_{13}} \times 100 (\%)$$

(Note 5)

$$\text{Setting Stability} = \left[\frac{R_{12}}{R_{13}} - \frac{r_{12}}{r_{13}} \right] \times 100 (\%)$$

- r13 : Resistance across #1 Terminal and #3 Terminal before test
- r12 : Resistance across #1 Terminal and #2 Terminal before test
- R13 : Resistance across #1 Terminal and #3 Terminal after test
- R12 : Resistance across #1 Terminal and #2 Terminal after test
- R23 : Resistance across #2 Terminal and #3 Terminal after test

4.4 Other Characteristics

ITEM	SPECIFICATION	TEST METHOD
Solderability	More than 90% of wetting where immersed portion.	5.13

5. Test Method

The tests and measurements should be conducted under the condition of 15 to 35°C of temperature, 25 to 75% of relative humidity and 86 to 106 kpa of atmospheric pressure unless otherwise specified. If questionable results occur that have been measured in accordance with the above mentioned conditions, the tests and measurements should be conducted under the condition of 25±2°C of temperature and, 45 to 55% of relative humidity and 86 to 106 kpa of atmospheric pressure. When the trimmer potentiometer is tested after soldering on PCB, it should be tested after being kept in a room (15 to 35°C, 25 to 75%RH) over 24 hours except " 5.12 Resistance to soldering heat".

5.1 Contact resistance variation (CRV)

Contact resistance variation should be measured with the measuring circuit shown below, or its equivalent. The operating wiper should be rotated in both directions through 90% of the actual effective electrical travel for a total of 6 cycles. The rate of rotation of the operating wiper should be such that the wiper completes 1 count in determining whether or not a contact resistance variation is observed at least twice in the same location.

[Measurement circuit]

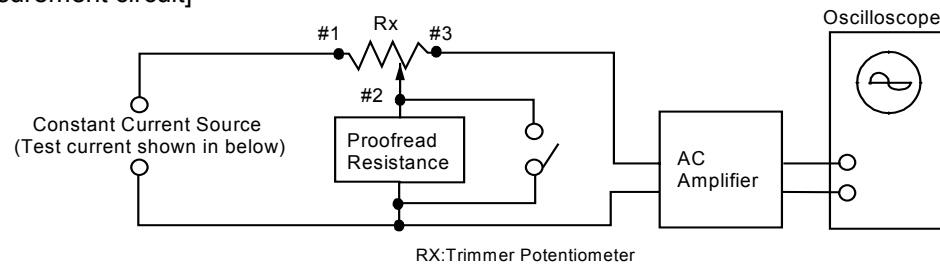

[Measurement wave]

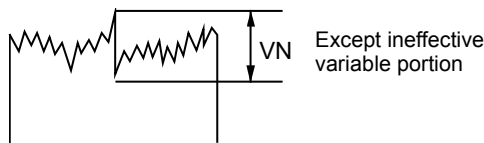

$$CRV = \left[\frac{VN}{IS \cdot RX} \right] \times 100(\%)$$

[Test current for CRV]

Nominal total resistance	Test current
220 ohm ≤ R < 10k ohm	10mA max.
10k ohm ≤ R < 100k ohm	1mA max.
100k ohm ≤ R	100μA max.

IS : Test current for CRV

RX: Nominal total resistance of trimmer potentiometer

VN: Noise voltage (peak to peak)

5.2 Temperature coefficient of resistance

The trimmer potentiometer should be subjected to each of the following temperatures (see Table 1) for 30 to 45 minutes. The resistance value should be measured in the chamber.

Table 1

Sequence	*1	2	*3	4
Temp. (°C)	+25±2	-25±3	+25±2	+85±3

Note)*: Norm Temp.

$$TC = \frac{R_2 - R_1}{R_1 (T_2 - T_1)} \times 10^6 \text{ (ppm/°C)}$$

T₁ : Reference temperature in degrees Celsius

T₂ : Test temperature in degrees Celsius

R₁ : Resistance at reference temperature in ohm

R₂ : Resistance at test temperature in ohm

5.3 Permitted force of Driver plate

A static load of 4.9N (Ref; 500gf) should be applied on the driver plate of the trimmer potentiometer for 5+1/-0 second. The load should be applied on driver plate uniformly by the 3mm-size plate of push-pull gage.

5.4 Soldering strength

The trimmer potentiometer should be soldered under the soldering condition described in paragraph 7.2(1) on standard land pattern described in 9. Outline dimensions. A static load of 9.8N (Ref; 1kgf) should be applied from rear side through the hole opened in the center of PCB by the 1.0±0.1mm dia. stick for 5 second.

5.5 High temperature exposure

The wiper contact point should be preset at about 50% position of effective rotational angle. After that, the trimmer potentiometer should be kept in a chamber at $70\pm 2^{\circ}\text{C}$ without loading for 500 ± 12 hours. The resistance value should be measured after keeping the trimmer potentiometer in a room for $1.5\pm 1/6$ hours.

5.6 Humidity exposure

The wiper contact point should be preset at about 50% position of effective rotational angle. After that, the trimmer potentiometer should be kept in a chamber at $40\pm 2^{\circ}\text{C}$ and 90 to 95% without loading for 500 ± 12 hours. The resistance value should be measured after keeping the trimmer potentiometer in a room for $5\pm 1/6$ hours.

5.7 Load life

The wiper contact point should be preset at about 50% position of effective rotational angle. After that, the trimmer potentiometer should be kept in a chamber at $50\pm 2^{\circ}\text{C}$ with loading the 1/2 rated voltage between #1 and #2 terminals, intermittently 1.5 hours ON and 0.5 hours OFF for 1000 ± 12 hours. The resistance value should be measured after keeping the trimmer potentiometer in a room for $1.5\pm 1/6$ hours.

5.8 Humidity load life

The wiper contact point should be preset at about 50% position of effective rotational angle. After that, the trimmer potentiometer should be kept in a chamber at $40\pm 2^{\circ}\text{C}$ and 90 to 95% with loading the 1/2 rated voltage between #1 and #2 terminals, intermittently 1.5 hours ON and 0.5 hours OFF for 1000 ± 12 hours. The resistance value should be measured after keeping the trimmer potentiometer in a room for $5\pm 1/6$ hours.

5.9 Temperature cycle

The wiper contact point should be preset at about 50% position of effective rotational angle. After that, the trimmer potentiometer should be subjected to Table 2 temperatures for 5 cycles. The resistance value should be measured after keeping the trimmer potentiometer in a room for $1.5\pm 1/6$ hours.

Table 2

Sequence	1	2	3	4
Temp. ($^{\circ}\text{C}$)	-25 ± 3	$+25\pm 2$	$+85\pm 3$	$+25\pm 2$
Time (min.)	30 ± 3	10 max.	30 ± 3	10 max.

5.10 Rotational life

The wiper should be rotated over 90% of the effective rotational angle without loading at a speed of 10 cycles per minute, for 10 cycles continuously. The resistance value should be measured after keeping the trimmer potentiometer in a room for 10 ± 5 minutes.

5.11 Vibration

The wiper contact point should be preset at about 50% position of effective rotational angle. After that, the trimmer potentiometer should be tested under the condition of the amplitude of 1.5mm, the frequency range from 10 to 55Hz (shall be traversed in approximately one minute) and 2 hours in each of 3 mutually perpendicular directions. (Total 6 hours)

5.12 Resistance to soldering heat

5.12.1

The trimmer potentiometer should be soldered under the soldering condition shown in Table 3. The resistance value should be measured after keeping the trimmer potentiometer in a room for 24+8/-0 hours.

Table 3

Pre-heating temperature	130 to 160°C
Pre-heating time	60 to 120 sec.
Soldering temperature	200°C
Soldering time	30sec. max.
Reflow peak temperature	240°C max.

5.12.2

The trimmer potentiometer should be soldered twice under the soldering condition shown in Table 4. The resistance value should be measured after keeping the trimmer potentiometer in a room for 24+8/-0 hours.

Table 4

Pre-heating temperature	150 to 180°C
Pre-heating time	60 to 120 sec.
Soldering temperature	220°C
Soldering time	30 to 60 sec.
Reflow peak temperature	260°C max.

5.13 Solderability

The trimmer potentiometer should be dipped into flux (Rosin type: chlorine 0.2% max., Solid content 30% max., Specific gravity 0.8 to 0.9), and dipped into solder bath at 230±5°C for 3.0±0.5 sec.

6.  Caution

- (1) Please contact us before using our products for the applications listed below which require especially high reliability for the prevention of defects that might directly cause damage to the third party's life, body or property.
 - Aircraft equipment
 - Aerospace equipment
 - Undersea equipment
 - Power plant equipment
 - Medical equipment
 - Transportation equipment (vehicles, trains, ships, etc.)
 - Traffic signal equipment
 - Disaster prevention / crime prevention equipment
 - Data-processing equipment
 - Applications of similar complexity and/or reliability requirements to the applications listed in the above
- (2) Be sure to provide an appropriate fail-safe function on your product to prevent a second damage that may be caused by an abnormality or failure related to our product.

7. Caution for Using

7.1 Mounting the product

Please use a pick-up nozzle with 2.5 to 2.8mm outer dia., 2mm inner dia.

7.2 Soldering

(1) Standard soldering condition for lead-free solder (96.5Sn-3.0Ag-0.5Cu)

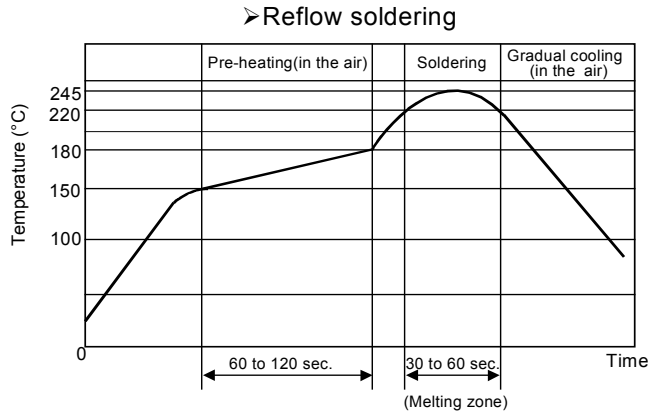

➤Soldering iron

Temperature of tip	: 360°C max.
Diameter	: 2mm max.
Soldering time	: 3 sec. max.
Wattage of iron	: 30W max.

Before using other soldering conditions than those listed above, please consult with a Murata factory representative prior to using. If the soldering conditions are not suitable, e.g., excessive time and/or excessive temperature, the trimmer potentiometer may deviate from the specified characteristics.

- (2) The amount of solder is critical. The thickness of solder paste should be printed from 100µm to 150µm and the dimension of land pattern should be used Murata's standard land pattern at re-flow soldering. Insufficient amounts of solder can lead to insufficient soldering strength on the PCB. Excessive amounts of solder may cause the bridging between the terminals or the contact failure due to flux wicking up.
- (3) The soldering iron should not come in contact with the resin substrate of the trimmer potentiometer. If such contact does occur, the trimmer potentiometer may be damaged.
- (4) PVZ3 series can not be flow soldering. If you use the flow soldering method, the trimmer potentiometer may not function.
- (5) Trimmer potentiometer is designed for the purpose of soldering. If you intend to connect with conductive adhesive or other method, please consult with a Murata factory representative prior to using.

7.3 Cleaning

In case there is flux on the resistive element, clean sufficiently by cleaning solvents and remove all residual flux perfectly. When cleaning the trimmer potentiometer, only use Isopropyl-alcohol and Ethyl-alcohol. If you use any other types of solvents, please evaluate performance by your set. Moreover, please confirm no damage for trimmer potentiometer after cleaning by your conditions.

7.4 Adjusting

- (1) PVZ3 series dose not have a mechanical stop for over rotation, so please use within the effective rotational angle. The #2 terminal is opened electrically out of effective rotational angle.
- (2) Please use suitable screwdrivers that fit comfortably in driver slot. We recommend the screwdrivers below.

Manufactures	Model Number	MURATA Model Number
VESSEL MFG.	NO.9000+1.7x30	KMDR080
VESSEL MFG.	NO.9000—1.8x30	KMDR110

- (3) When using a lock paint to fix adjustment position, please evaluate performance by your set. Lock paint may become the cause of corrosion and contact fault.

7.5 Operating environmental conditions

The trimmer potentiometer should not be used under the following environmental conditions.

If you use the trimmer potentiometer in an environment other than listed below, please consult with a Murata factory representative prior to using.

- (1) Corrosive gaseous atmosphere. (e.g. Cl_2 , H_2S , NH_3 , SO_2 , NO_x etc)
- (2) In liquid. (Ex. Water, Oil, Medical liquid, Organic solvent, etc)
- (3) Dusty/dirty atmosphere.
- (4) Direct sunlight.
- (5) No static voltage or electric/magnetic fields.
- (6) Direct sea breeze.
- (7) Other variations of the above.

7.6 Storage Conditions

- (1) To ensure the solderability of the terminal, store that the temperature is -10 to $+40^{\circ}C$ and the relative humidity is 30 to 85% RH, and use within six months after delivery. If you are going to use a product that has been stored for more than six months, please check its solderability beforehand.
- (2) Do not store in or near corrosive gases.
- (3) Do not store under direct sunlight.

7.7 Circuit design guide

- (1) Please confirm specifications of required trimmer potentiometers (power rating, maximum operating voltage, operating temperature, etc.).
- (2) When using with partial load (rheostat), minimize the power depending on the resistance value.
- (3) If the trimmer potentiometer is used in DC and high humidity conditions, please connect wiper (#2) for plus and resistive element (#1 or #3) for minus.

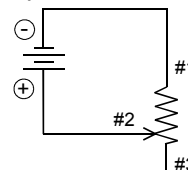

- (4) Use trimmer potentiometer within 90% of the effective-electrical rotational angle to prevent a sudden change of resistance when excessive current is applied.
- (5) The maximum input voltage to a trimmer potentiometer should not exceed $(P \cdot R)^{1/2}$ or the maximum operating voltage, whichever is smaller.
*P: Power rating (W)
R: Normal resistance value (ohm)
- (6) If the mounting process includes reflow soldering for the upper side of the PCB and flow soldering for its lower side and a product is mounted on the upper side by reflow soldering without cleaning, take the following cautions in order to prevent the flux from flowing onto the wiper sliding surface.
 1. Don't place the product within 10 mm from the outer edge of the PCB.
 2. Don't provide a through hole near the product.
(A distance of 10 mm or more between the product and a through hole is necessary.)

8. ⚠ Notice

- (1) Please make sure that your product has been evaluated in view of your specifications with our product being mounted to your product.
- (2) You are requested not to use our product deviating from the agreed specifications.
- (3) Please return one duplicate of this product specification to us with your receipt signature. If the duplicate is not returned, this product specification will be deemed to have been received by you.
- (4) We consider it is not appropriate to include any terms and conditions with regard to the business transaction in the product specifications, drawings or other technical documents. Therefore, if your technical documents as above include such terms and conditions such as warranty clause, product liability clause, or intellectual property infringement liability clause, they will be deemed to be invalid.

9. Outline Dimensions

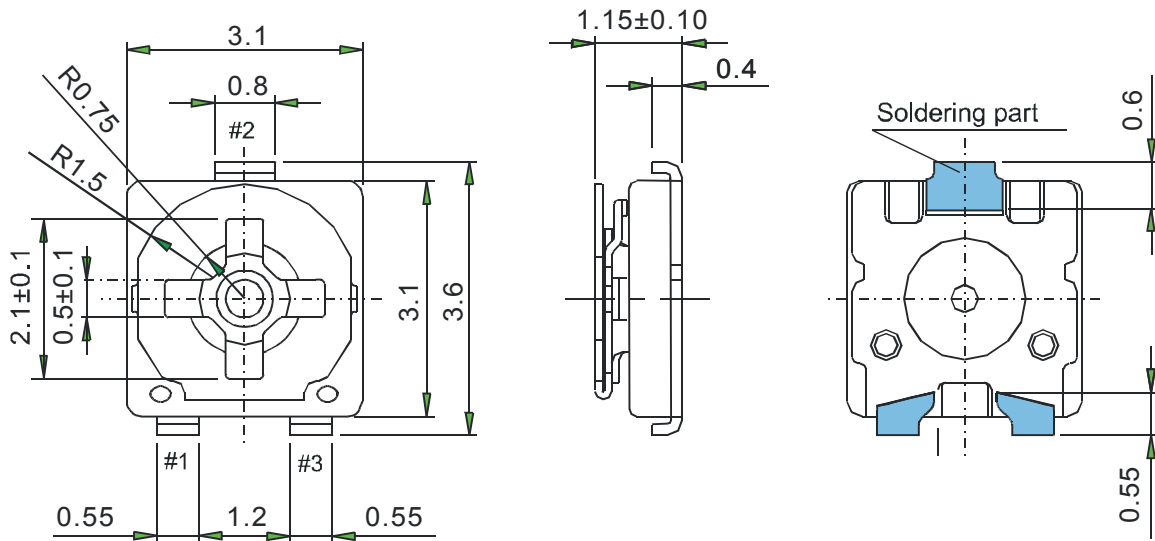

(Unit: mm)
(Tolerance: ±0.3)

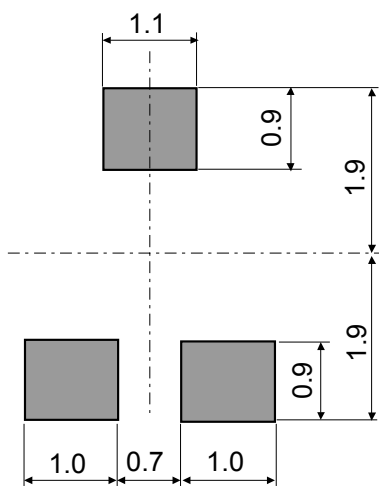
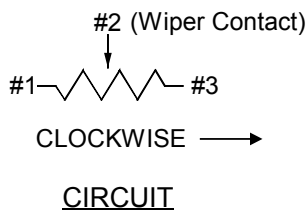

Standard Land Pattern

(Unit: mm)
(Tolerance: ±0.1)

The resistance value should be indicated with two digits at the OO portions above.

Resistance value	Indicated by 2 digits	Resistance value	Indicated by 2 digits
220 ohm	22	33k ohm	34
330 ohm	32	47k ohm	54
470 ohm	52	68k ohm	64
680 ohm	62	100k ohm	15
1k ohm	13	150k ohm	05
1.5k ohm	03	220k ohm	25
2.2k ohm	23	330k ohm	35
3.3k ohm	33	470k ohm	55
4.7k ohm	53	680k ohm	65
6.8k ohm	63	1M ohm	16
10k ohm	14	1.5M ohm	06
15k ohm	04	2.2M ohm	26
22k ohm	24		

11. Part Number Cross Reference Table

➤PVZ3G□□□C01B00 (Bulk)

Customer's part No.	Murata part No.
	PVZ3G221C01B00
	PVZ3G331C01B00
	PVZ3G471C01B00
	PVZ3G681C01B00
	PVZ3G102C01B00
	PVZ3G152C01B00
	PVZ3G222C01B00
	PVZ3G332C01B00
	PVZ3G472C01B00
	PVZ3G682C01B00
	PVZ3G103C01B00
	PVZ3G153C01B00
	PVZ3G223C01B00
	PVZ3G333C01B00
	PVZ3G473C01B00
	PVZ3G683C01B00
	PVZ3G104C01B00
	PVZ3G154C01B00
	PVZ3G224C01B00
	PVZ3G334C01B00
	PVZ3G474C01B00
	PVZ3G684C01B00
	PVZ3G105C01B00
	PVZ3G155C01B00
	PVZ3G225C01B00

➤PVZ3G□□□C01R00 (Standard Taping)

Customer's part No.	Murata part No.
	PVZ3G221C01R00
	PVZ3G331C01R00
	PVZ3G471C01R00
	PVZ3G681C01R00
	PVZ3G102C01R00
	PVZ3G152C01R00
	PVZ3G222C01R00
	PVZ3G332C01R00
	PVZ3G472C01R00
	PVZ3G682C01R00
	PVZ3G103C01R00
	PVZ3G153C01R00
	PVZ3G223C01R00
	PVZ3G333C01R00
	PVZ3G473C01R00
	PVZ3G683C01R00
	PVZ3G104C01R00
	PVZ3G154C01R00
	PVZ3G224C01R00
	PVZ3G334C01R00
	PVZ3G474C01R00
	PVZ3G684C01R00
	PVZ3G105C01R00
	PVZ3G155C01R00
	PVZ3G225C01R00



11. Part Number Cross Reference Table

➤PVZ3G□□□C01R02 (Option Taping)

Customer's part No.	Murata part No.
	PVZ3G221C01R02
	PVZ3G331C01R02
	PVZ3G471C01R02
	PVZ3G681C01R02
	PVZ3G102C01R02
	PVZ3G152C01R02
	PVZ3G222C01R02
	PVZ3G332C01R02
	PVZ3G472C01R02
	PVZ3G682C01R02
	PVZ3G103C01R02
	PVZ3G153C01R02
	PVZ3G223C01R02
	PVZ3G333C01R02
	PVZ3G473C01R02
	PVZ3G683C01R02
	PVZ3G104C01R02
	PVZ3G154C01R02
	PVZ3G224C01R02
	PVZ3G334C01R02
	PVZ3G474C01R02
	PVZ3G684C01R02
	PVZ3G105C01R02
	PVZ3G155C01R02
	PVZ3G225C01R02

Looking for pricing, stock, or lifecycle information?

Click below to explore more details on WIN SOURCE:

-  [View PVZ3G103C01R00 on WIN SOURCE](#)
-  [Bourns Inc. Information](#)

Optimize Your Supply Chain with WIN SOURCE Solutions

-  Global Sourcing Solution
-  Obsolete Management
-  Cost Control Management
-  Shortage Management
-  Alternative Solution
-  Excess Inventory Management