



**THE DATASHEET OF
PTH08000WAZT**



2.25-A, WIDE INPUT, ADJUSTABLE SWITCHING REGULATOR WITH AUTO-TRACK™ SEQUENCING



FEATURES

- Up to 2.25-A Output Current at 85°C
- 4.5-V to 14-V Input Voltage Range
- Wide-Output Voltage Adjust (0.9 V to 5.5 V)
- Efficiencies Up to 94%
- On/Off Inhibit
- Undervoltage Lockout (UVLO)
- Output Overcurrent Protection (Nonlatching, Auto-Reset)
- Overtemperature Protection
- Ambient Temperature Range: –40°C to 85°C
- Surface-Mount Package

- Safety Agency Approvals: UL/CUL 60950, EN60950

APPLICATIONS

- Telecommunications, Instrumentation, and General-Purpose Circuits

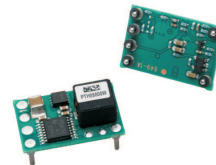

DESCRIPTION

The PTH08000W is a highly integrated, low-cost switching regulator module that delivers up to 2.25 A of output current. The PTH08000W sources output current at a much higher efficiency than a TO-220 linear regulator IC, eliminating the need for a heatsink. The small size (0.75 inch × 0.5 inch) and flexible operation creates value for a variety of applications.

The input voltage range of the PTH08000W is 4.5 V to 14 V, allowing operation from either a 5-V or 12-V input bus. Using state-of-the-art switched-mode power-conversion technology, the PTH08000W can step down to voltages as low as 0.9 V from a 5-V input bus, with less than 1 W of power dissipation. The output voltage can be adjusted to any voltage over the range, 0.9 V to 5.5 V, using a single external resistor. This series includes Auto-Track™ sequencing. This feature simplifies the task of supply voltage sequencing in a power system by enabling modules to track each other, or any external voltage, during power up and power down. Operating features include an undervoltage lockout (UVLO), on/off inhibit, overcurrent protection, and overtemperature protection. Target applications include telecommunications, test and measurement applications, and high-end consumer products. This product is available in both through-hole and surface-mount package options, including tape and reel. The PTH08000W is compatible with TI's roadmap for RoHS and lead-free compliance.

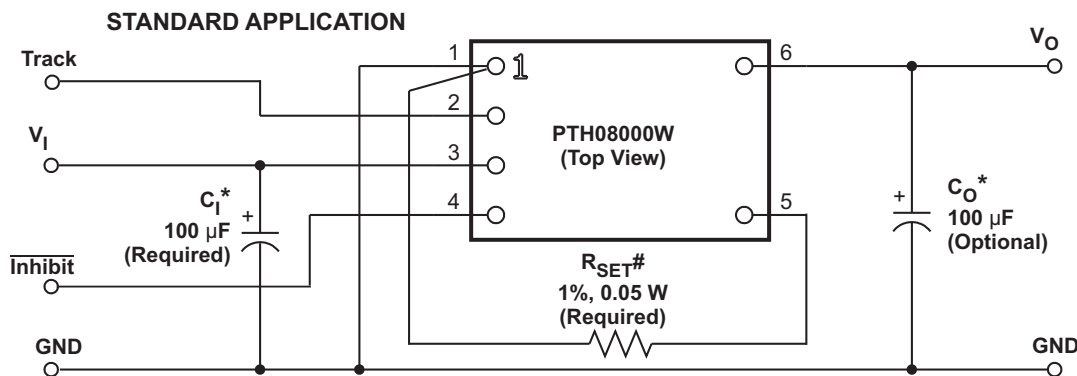

* See the Application Information section for capacitor recommendations.

See the Application Information section for R_{SET} values.



Please be aware that an important notice concerning availability, standard warranty, and use in critical applications of Texas Instruments semiconductor products and disclaimers thereto appears at the end of this data sheet.

Auto-Track, POLA, TMS320 are trademarks of Texas Instruments.



These devices have limited built-in ESD protection. The leads should be shorted together or the device placed in conductive foam during storage or handling to prevent electrostatic damage to the MOS gates.

ORDERING INFORMATION

For the most current package and ordering information, see the Package Option Addendum at the end of this datasheet, or see the TI website at www.ti.com.

ABSOLUTE MAXIMUM RATINGS

over operating free-air temperature range unless otherwise noted⁽¹⁾

			PTH08000W	UNIT
T_A	Operating free-air temperature	Over V_I range	–40 to 85	°C
	Lead temperature (H suffix)	5 seconds	260	°C
	Solder reflow temperature (S suffix)	Surface temperature of module body or pins	235	
	Solder reflow temperature (Z suffix) ⁽²⁾	Surface temperature of module body or pins	260	
T_{stg}	Storage temperature		–55 to 125	°C

- (1) Stresses beyond those listed under absolute maximum ratings may cause permanent damage to the device. These are stress ratings only, and functional operation of the device at these or any other conditions beyond those indicated under recommended operating conditions is not implied. Exposure to absolute-maximum-rated conditions for extended periods may affect device reliability
- (2) Moisture Sensitivity Level (MSL) Rating Level-3-260C-168HR

RECOMMENDED OPERATING CONDITIONS

		MIN	MAX	UNIT
V_I	Input voltage	4.5	14	V
T_A	Operating free-air temperature	–40	85	°C

PACKAGE SPECIFICATIONS

PTH08000W (Suffix AH, AS, and AZ)		
Weight		1.5 grams
Flammability	Meets UL 94 V-O	
Mechanical shock	Per Mil-STD-883D, Method 2002.3, 1 ms, sine, mounted	500 G ⁽¹⁾
Mechanical vibration	Mil-STD-883D, Method 2007.2, 20-2000 Hz	20 G ⁽¹⁾

- (1) Qualification limit.

ELECTRICAL CHARACTERISTICS

 at 25°C free-air temperature, $V_I = 12\text{ V}$, $V_O = 3.3\text{ V}$, $I_O = I_{Omax}$, $C_I = 100\text{ }\mu\text{F}$ (unless otherwise noted)

PARAMETER		TEST CONDITIONS	MIN	TYP	MAX	UNIT
I_O	Output current	$T_A = 85^\circ\text{C}$, natural convection airflow	0		2.25	A
V_I	Input voltage range	Over I_O range	4.5 ⁽¹⁾		14	V
V_O	Set-point voltage tolerance	$T_A = 25^\circ\text{C}$			2 ⁽²⁾	%
	Temperature variation	$-40^\circ\text{C} \leq T_A \leq 85^\circ\text{C}$		0.5		% V_O
	Line regulation	Over V_I range		7		mV
	Load regulation	Over I_O range		0.13		% V_O
	Total output voltage variation	Includes set-point, line, load, $-40^\circ\text{C} \leq T_A \leq 85^\circ\text{C}$				3 ⁽²⁾
$V_{(ADJ)}$	Output Voltage Adjust Range	Over I_O range	0.9		5.5	V
η	Efficiency	$T_A = 25^\circ\text{C}$, $I_O = 2\text{ A}$	$R_{SET} = 346\text{ }\Omega$, $V_O = 5\text{ V}$		93.5%	
			$R_{SET} = 1.87\text{ k}\Omega$, $V_O = 3.3\text{ V}$		92%	
			$R_{SET} = 3.74\text{ k}\Omega$, $V_O = 2.5\text{ V}$		90.5%	
			$R_{SET} = 6.19\text{ k}\Omega$, $V_O = 2\text{ V}$		89.5%	
			$R_{SET} = 8.06\text{ k}\Omega$, $V_O = 1.8\text{ V}$		88%	
			$R_{SET} = 13\text{ k}\Omega$, $V_O = 1.5\text{ V}$		86.5%	
			$R_{SET} = 27.4\text{ k}\Omega$, $V_O = 1.2\text{ V}$		84.5%	
	Output voltage ripple	20-MHz bandwidth		40		mV _{PP}
	Overcurrent threshold	Reset, followed by autorecovery		3.5		A
	Transient response	$C_O = 100\text{ }\mu\text{F}$, 1 A/ μs load step from 50% to 100% I_{Omax}	Recovery time		50	μs
			V_O over/undershoot		100	mV
$I_{IL\text{ track}}$	Track input current (pin 2)	Pin to GND			-130	μA
dV_{track}/dt	Track slew rate capability	$C_O \leq C_{O(max)}$			1	V/ms
UVLO	Undervoltage lockout	$V_I = \text{increasing}$		4.35	4.5	V
		$V_I = \text{decreasing}$	3.6	4		
	Inhibit control (pin 4)	Input high voltage (V_{IH})			Open ⁽³⁾	V
		Input low voltage (V_{IL})	-0.2		0.5	
		Input low current (I_{IL})		-5		
I_i (stby)	Input standby current	Pins 5 and 2 connected		1		mA
f_s	Switching frequency	Over V_I and I_O ranges		300		kHz
	External input capacitance	Electrolytic type (C_I)	100 ⁽⁴⁾			μF
	External output capacitance	Ceramic type (C_O)			220	μF
		Nonceramic type (C_O)		100 ⁽⁵⁾	330 ⁽⁶⁾	
		Equivalent series resistance (nonceramic)	10 ⁽⁷⁾			
MTBF	Calculated reliability	Per Telcordia SR-332, 50% stress, $T_A = 40^\circ\text{C}$, ground benign	10.3			10^6 Hr

- The minimum input voltage is 4.5 V or ($V_O + 1.1$) V, whichever is greater.
- The set-point voltage tolerance is affected by the tolerance and stability of R_{SET} . The stated limit is unconditionally met if R_{SET} has a tolerance of 1% with 100 ppm/ $^\circ\text{C}$ or better temperature stability.
- This control pin has an internal pull-up to 3 V (TYP). Do not place an external pull-up on this pin. If it is left open-circuit, the module operates when input power is applied. A small, low-leakage (< 100 nA) MOSFET is recommended for control. See the Application section for further guidance.
- An external 100- μF electrolytic capacitor is required across the input (V_I and GND) for proper operation. Locate the capacitor close to the module.
- An external output capacitor is not required for proper operation. Adding 100 μF of distributed capacitance at the load improves the transient response.
- This is the calculated maximum capacitance. The minimum ESR limitation often results in a lower value. See the capacitor application information for further guidance.
- This is the minimum ESR for all the electrolytic (nonceramic) capacitance. Use 14 m Ω as the minimum when calculating the total equivalent series resistance (ESR) using the maximum ESR values specified by the capacitor manufacturer.

PIN ASSIGNMENT

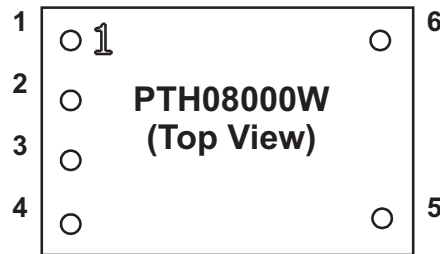

TERMINAL FUNCTIONS

TERMINAL		I/O	DESCRIPTION
NAME	NO.		
GND	1		This is the common ground connection for the V_I and V_O power connections. It is also the 0- V_{DC} reference for the <i>Inhibit</i> , V_O <i>Adjust</i> , and <i>Track</i> control inputs.
Track	2	I	This is an analog control input that enables the output voltage to follow an external voltage. This pin becomes active typically 20 ms after the input voltage has been applied, and allows direct control of the output voltage from 0 V up to the nominal set-point voltage. Within this range, the output voltage follows the voltage at the Track pin on a volt-for-volt basis. When the control voltage is raised above this range, the module regulates at its set-point voltage. The feature allows the output voltage to rise simultaneously with other modules powered from the same input bus. If unused, this input should be connected to V_I . <i>NOTE: Due to the undervoltage lockout feature, the output of the module cannot follow its own input voltage during power up. For more information, consult the related application section.</i>
V_I	3	I	The positive input voltage power node to the module, which is referenced to common GND.
Inhibit	4	I	The Inhibit pin is an open-collector/drain-negative logic input that is referenced to GND. Applying a low-level ground signal to this input disables the module's output. When the Inhibit control is active, the input current drawn by the regulator is significantly reduced. If the Inhibit pin is left open-circuit, the module produces an output voltage whenever a valid input source is applied. Do not place an external pull-up on this pin.
V_O Adjust	5	I	A 1% resistor must be connected between this pin and GND (pin 1) to set the output voltage of the module higher than 0.9 V. If left open-circuit, the output voltage defaults to this value. The temperature stability of the resistor should be 100 ppm/°C (or better). The set-point range is from 0.9 V to 5.5 V. The electrical specification table gives the standard resistor value for a number of common output voltages. See the application information for further guidance.
V_O	6	O	The regulated positive power output with respect to the GND node.

TYPICAL CHARACTERISTICS (5-V INPUT)⁽¹⁾⁽²⁾

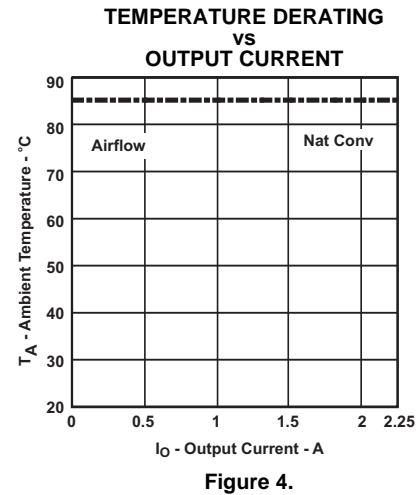
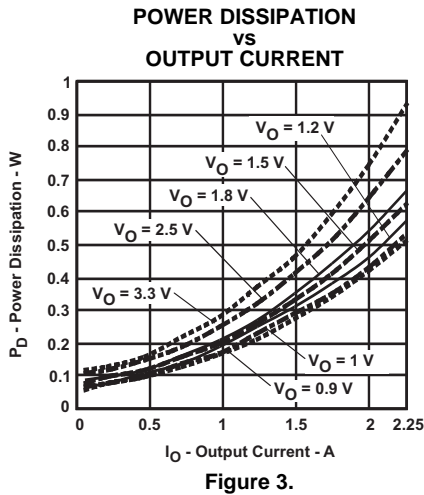
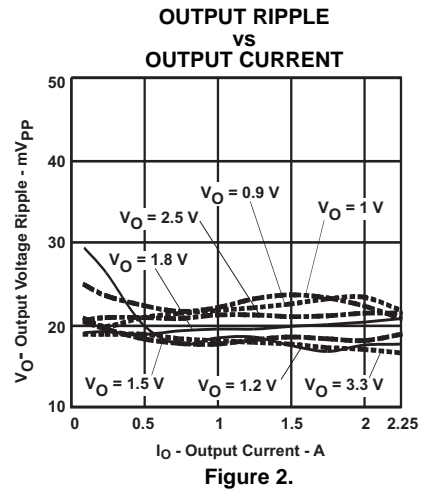
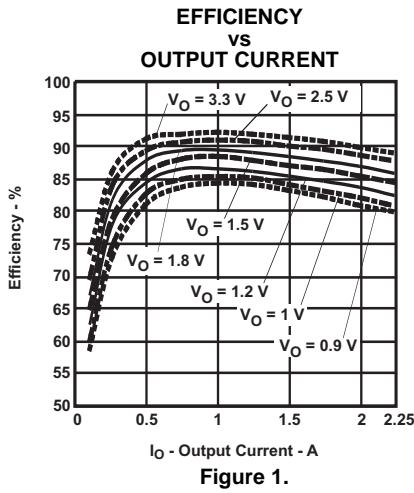

- (1) The electrical characteristic data has been developed from actual products tested at 25°C. This data is considered typical for the converter. Applies to [Figure 1](#), [Figure 2](#), and [Figure 3](#).
- (2) The temperature derating curves represent the conditions at which internal components are at or below the manufacturer's maximum operating temperatures. Derating limits apply to modules soldered directly to a 100-mm x 100-mm, double-sided PCB with 2-oz. copper. Applies to [Figure 4](#).

TYPICAL CHARACTERISTICS (12-V INPUT)⁽¹⁾⁽²⁾

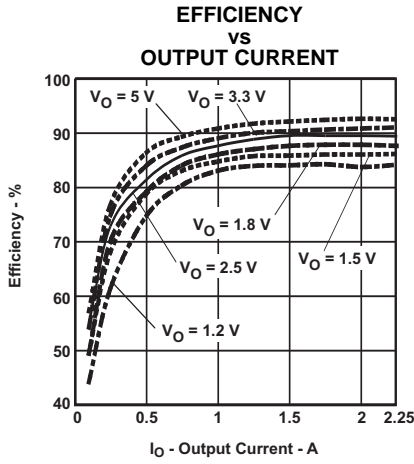

Figure 5.

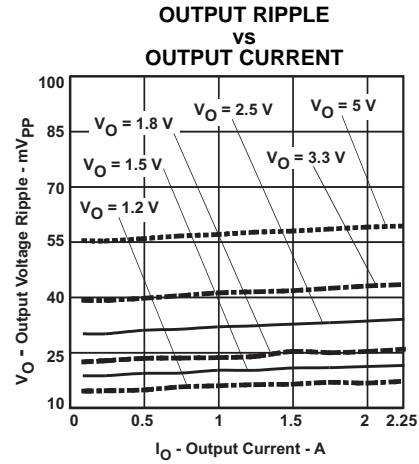

Figure 6.

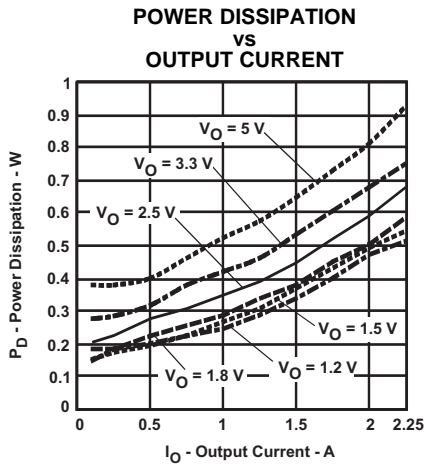

Figure 7.

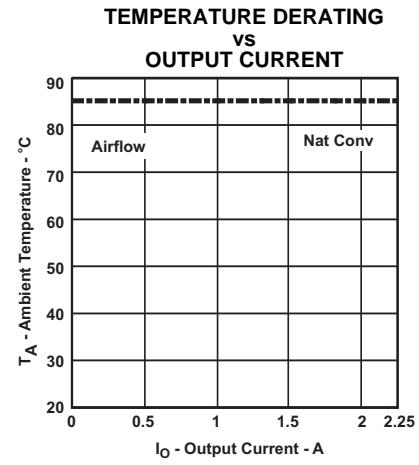

Figure 8.

- (1) The electrical characteristic data has been developed from actual products tested at 25°C. This data is considered typical for the converter. Applies to [Figure 5](#), [Figure 6](#), and [Figure 7](#).
- (2) The temperature derating curves represent the conditions at which internal components are at or below the manufacturer's maximum operating temperatures. Derating limits apply to modules soldered directly to a 100-mm x 100-mm, double-sided PCB with 2-oz. copper. Applies to [Figure 8](#).

APPLICATION INFORMATION

Adjusting the Output Voltage of the PTH08000W Wide-Output Adjust Power Modules

The V_O Adjust control (pin 5) sets the output voltage of the PTH08000W product. The adjustment range is from 0.9 V to 5.5 V. The adjustment method requires the addition of a single external resistor, R_{SET} , that must be connected directly between the V_O Adjust and GND (pin 1). Table 1 gives the standard external resistor for a number of common bus voltages, along with the actual voltage the resistance produces.

For other output voltages, the value of the required resistor can either be calculated using the following formula, or simply selected from the range of values given in Table 2. Figure 9 shows the placement of the required resistor.

$$R_{SET} = 10 \text{ k}\Omega \times \frac{0.891 \text{ V}}{V_O - 0.9 \text{ V}} - 1.82 \text{ k}\Omega$$

Table 1. Standard Values of R_{SET} for Common Output Voltages

V_O (V) (Required)	R_{SET} (k Ω) (Standard Value)	V_O (V) (Actual)
5 ⁽¹⁾	0.348	5.010
3.3	1.87	3.315
2.5	3.74	2.503
2	6.19	2.012
1.8	8.06	1.802
1.5	13.0	1.501
1.2	27.4	1.205
1	86.6	1.001
0.9	Open	0.9

(1) The minimum input voltage is 4.5 V or ($V_O + 1.1$) V, whichever is greater.

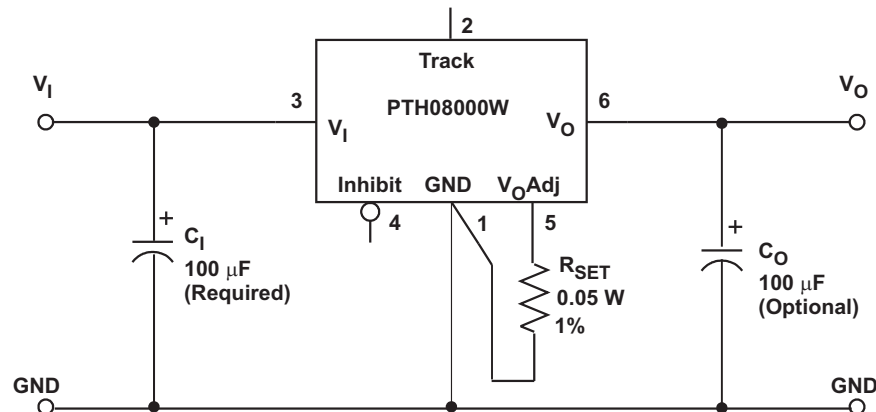

- (1) A 0.05-W rated resistor may be used. The tolerance should be 1%, with a temperature stability of 100 ppm/ $^{\circ}$ C (or better). Place the resistor as close to the regulator as possible. Connect the resistor directly between pins 5 and 1 using dedicated PCB traces.
- (2) Never connect capacitors from V_O Adjust to either GND or V_O . Any capacitance added to the V_O Adjust pin affects the stability of the regulator.

Figure 9. V_O Adjust Resistor Placement

Table 2. Calculated Set-Point Resistor Values

V _O Required	R _{SET}	V _O Required	R _{SET}	V _O Required	R _{SET}
0.900	Open	1.800	8.08 kΩ	3.700	1.36 kΩ
0.925	355 kΩ	1.850	7.56 kΩ	3.750	1.32 kΩ
0.950	176 kΩ	1.900	7.09 kΩ	3.800	1.25 kΩ
0.975	117 kΩ	1.950	6.67 kΩ	3.850	1.20 kΩ
1.000	87.2 kΩ	2.000	6.28 kΩ	3.900	1.15 kΩ
1.025	69.5 kΩ	2.050	5.92 kΩ	3.950	1.10 kΩ
1.050	57.6 kΩ	2.100	5.61 kΩ	4.000	1.05 kΩ
1.075	49.1 kΩ	2.150	5.31 kΩ	4.050	1.01 kΩ
1.100	42.7 kΩ	2.200	5.03 kΩ	4.100	964 Ω
1.125	37.8 kΩ	2.250	4.78 kΩ	4.150	922 Ω
1.150	33.8 kΩ	2.300	4.54 kΩ	4.200	880 Ω
1.175	30.6 kΩ	2.350	4.33 kΩ	4.250	840 Ω
1.200	27.9 kΩ	2.400	4.12 kΩ	4.300	801 Ω
1.225	25.6 kΩ	2.450	3.93 kΩ	4.350	763 Ω
1.250	23.6 kΩ	2.500	3.75 kΩ	4.400	726 Ω
1.275	21.9 kΩ	2.550	3.58 kΩ	4.450	690 Ω
1.300	20.5 kΩ	2.600	3.42 kΩ	4.500	655 Ω
1.325	19.1 kΩ	2.650	3.27 kΩ	4.550	621 Ω
1.350	17.9 kΩ	2.700	3.13 kΩ	4.600	588 Ω
1.375	16.9 kΩ	2.750	2.99 kΩ	4.650	556 Ω
1.400	14.6 kΩ	2.800	2.87 kΩ	4.700	525 Ω
1.425	13.7 kΩ	2.850	2.75 kΩ	4.750	494 Ω
1.450	13.0 kΩ	2.900	2.64 kΩ	4.800	465 Ω
1.475	13.7 kΩ	2.950	2.53 kΩ	4.850	436 Ω
1.500	13.0 kΩ	3.000	2.42 kΩ	4.900	408 Ω
1.525	12.4 kΩ	3.050	2.32 kΩ	4.950	380 Ω
1.550	11.9 kΩ	3.100	2.23 kΩ	5.000	353 Ω
1.575	11.4 kΩ	3.150	2.14 kΩ	5.050	327 Ω
1.600	10.9 kΩ	3.200	2.05 kΩ	5.100	301 Ω
1.625	10.5 kΩ	3.250	1.97 kΩ	5.150	276 Ω
1.650	10.0 kΩ	3.300	1.89 kΩ	5.200	252 Ω
1.675	9.68 kΩ	3.350	1.82 kΩ	5.250	228 Ω
1.700	9.32 kΩ	3.400	1.74 kΩ	5.300	205 Ω
1.725	8.98 kΩ	3.450	1.67 kΩ	5.350	182 Ω
1.750	8.66 kΩ	3.500	1.61 kΩ	5.400	160 Ω
1.775	8.36 kΩ	3.550	1.54 kΩ	5.450	138 Ω
1.800	8.08 kΩ	3.600	1.48 kΩ	5.500	117 Ω
1.825	7.81 kΩ	3.650	1.42 kΩ		

CAPACITOR RECOMMENDATIONS FOR THE PTH08000W WIDE-OUTPUT ADJUST POWER MODULES

Input Capacitor

The minimum required input capacitor is 100 μF of capacitance. When $V_O > 3.4\text{ V}$, the 100- μF electrolytic capacitance must be rated for 650-mArms ripple current. For $V_O < 3.4\text{ V}$, the ripple current rating must be at least 500 mArms. The ripple current rating of electrolytic capacitors is a major consideration when they are used at the input.

When specifying regular tantalum capacitors for use at the input, a minimum voltage rating of $2 \times$ (maximum dc voltage + ac ripple) is highly recommended. This is standard practice to ensure reliability. Polymer-tantalum capacitors are not affected by this requirement.

For improved ripple reduction on the input bus, ceramic capacitors can also be added to complement the required electrolytic capacitance.

Output Capacitors (Optional)

No output capacitance is required for normal operation. However, applications with load transients (sudden changes in load current) can benefit by adding external output capacitance. A 100- μF electrolytic or ceramic capacitor can be used to improve transient response. Adding a 100- μF nonceramic capacitor allows the module to meet its transient response specification. A high-quality computer-grade electrolytic capacitor should be adequate.

Electrolytic capacitors should be located close to the load circuit. These capacitors provide decoupling over the frequency range, 2 kHz to 150 kHz. Aluminum electrolytic capacitors are suitable for ambient temperatures above 0°C. For operation below 0°C, tantalum or Os-Con-type capacitors are recommended. When using one or more nonceramic capacitors, the calculated equivalent ESR should be no lower than 10m Ω (14m Ω using the manufacturer's maximum ESR for a single capacitor). A list of preferred low-ESR-type capacitors are identified in [Table 3](#).

Ceramic Capacitors

Above 150 kHz, the performance of aluminum electrolytic capacitors becomes less effective. To further improve the reflected input ripple current, or the output transient response, multilayer ceramic capacitors must be added. Ceramic capacitors have low ESR and their resonant frequency is higher than the bandwidth of the regulator. When placed at the output, their combined ESR is not critical as long as the total value of ceramic capacitance does not exceed 220 μF . Also, to prevent the formation of local resonances, do not exceed the maximum number of capacitors specified in the capacitor table.

Tantalum Capacitors

Additional tantalum-type capacitors can be used at both the input and output, and are recommended for applications where the ambient operating temperature can be less than 0°C. The AVX TPS, Sprague 593D/594/595, and Kemet T495/T510/T520 capacitors series are suggested over many other tantalum types due to their rated surge, power dissipation, and ripple current capability. As a caution, many general-purpose tantalum capacitors have considerably higher ESR and lower ripple current capability. These capacitors are also less reliable as they have lower power dissipation capability and surge current ratings. Tantalum capacitors that do not have a stated ESR or surge current rating are not recommended for power applications. When specifying Os-Con and polymer-tantalum capacitors for the output, the minimum ESR limit is encountered well before the maximum capacitance value is reached.

Capacitor Table

The capacitor table, [Table 3](#), identifies the characteristics of capacitors from a number of vendors with acceptable ESR and ripple current (rms) ratings. The recommended number of capacitors required at both the input and output buses is identified for each capacitor type. This is not an extensive capacitor list. Capacitors from other vendors are available with comparable specifications. Those listed are for guidance. The rms rating and ESR (at 100 kHz) are critical parameters necessary to ensure both optimum regulator performance and long capacitor life.

Table 3. Recommended Input/Output Capacitors ⁽¹⁾

CAPACITOR VENDOR/ COMPONENT SERIES	CAPACITOR CHARACTERISTICS					QUANTITY		VENDOR NUMBER
	WORKING VOLTAGE (V)	VALUE (μ F)	EQUIVALENT SERIES RESISTANCE (ESR) (Ω)	85°C MAXIMUM RIPPLE CURRENT (I _{RMS}) (mA)	PHYSICAL SIZE (mm)	INPUT BUS ⁽²⁾	OUTPUT BUS	
Panasonic WA (SMT)	20	150	0.026	3700	10 × 10,2	1	≤ 2	EEFWA1D151P
FC (SMT)	25	220	0.150	670	10 × 10,2	1	1	EEVFC1E221P
Panasonic SL	6.3	47	0.018	2500	7,3 × 4,3	N/R ⁽³⁾	≤ 3	EEFCDOJ470R
SP-cap(SMT)	6.3	120	0.007	3500	7,3 × 4,3	N/R ⁽³⁾	≤ 1	EEFSD0J121R
United Chemi-con								
PXA (SMT)	16	150	0.026	3400	10 × 7,7	1	≤ 2	PXA16VC151MJ80TP
PS	25	100	0.020	4300	10 × 12,5	1	≤ 2	25PS100MJ12
LXZ	35	220	0.180	760	10 × 12,5	1	1	LXZ35VB221M10X12LL
MVY (SMT)	35	333	0.150	670	10 × 10	1	1	MVY35VC331MJ10TP
Nichicon UWG (SMT)	35	100	0.150	670	10 × 10	1	1	UWG1V101MNR1GS
F559(Tantalum)	10	100	0.055	2000	7,7 × 4,3	N/R ⁽⁴⁾	≤ 3	F551A107MN
HD	25	220	0.072	760	8 × 11,5	1	1	UHD1E221MPR
Sanyo Os-con\ POS-Cap	10	68	0.025	2400	7,3 × 4,3	N/R ⁽⁴⁾	≤ 2	10TPE68M
SVP (SMT)	20	150	0.020	4320	10 × 12,7	1	≤ 1	20SVP150M
SP	20	120	0.024	3110	8 × 10,5	1	≤ 2	20SP120M
AVX Tantalum TPS (SMD)	35	47	0.100	1430	7,3 × 4,3 × 4,1	2	≤ 4	TPSV476M035R0100
	25	47	0.100	1150	7,3 × 4,3 × 4,1	2	≤ 4	TPSE476M025R0100 (V _I <13V)
Kemet T520 (SMD)	10	100	0.025	> 2000	7,3 × 5,7 × 4	N/R ⁽⁴⁾	≤ 1	T520V107M010ASE025
AO-CAP	6.3	100	0.018	> 2900	7,3 × 5,7 × 4	N/R ⁽⁴⁾	≤ 1	A700V107M006AT
Vishay/Sprague	35	47	0.280	> 1000	7,3 × 6 × 4,1	2	≤ 5	595D476X0035R2T
594D/SVP(SMD)	20	100	0.025	3200	8 × 12	1	≤ 2	94SVP107X0020E12
94SS	20	150	0.030	3200	10 × 10,5	1	≤ 2	94SS157X0020FBP
Murata Ceramic X5R	16	47	0.002	> 1400	3225	1 ⁽⁵⁾	≤ 3	GRM32ER61C476M
TDK ceramic X5R	6.3	47	0.002	> 1400	3225	N/R ⁽⁴⁾	≤ 3	C3225X5R0J476MT (V _O <5.5V)
Kemet Ceramic X5R	6.3	47	0.002	> 1400	3225	N/R ⁽⁴⁾	≤ 3	C1210C476K9PAC (V _O <5.5V)
TDK Ceramic X7R	25	10	0.002	> 1400	3225	1 ⁽⁵⁾	≤ 4	C3225X7R1E106K
Murata Ceramic X5R	25	10	0.002	> 1400	3225	1 ⁽⁵⁾	≤ 4	GRM32DR61E106KA12
Kemet	16	10	0.002	> 1400	3225	1 ⁽⁵⁾	≤ 4	C1210C106M4PAC
TDK Ceramic X7R	25	2.2	0.002	> 1400	3225	1	1	C3225X7R1E225KT/MT
Murata Ceramic X7R	25	2.2	0.002	> 1400	3225	1	1	GRM32RR71J225KC01L
Kemet	25	2.2	0.002	> 1400	3225	1	1	C1210C225K3RAC

- (1) Check with capacitor manufacturers for availability and lead-free status.
- (2) The voltage rating of the input capacitor must be selected for the desired operating input voltage range of the regulator. To operate the regulator at a higher input voltage, select a capacitor with a higher voltage rating.
- (3) Not Recommended (N/R). The voltage rating of this capacitor does not meet the minimum operating limit in most applications.
- (4) Not Recommended (N/R). The voltage rating of this capacitor does not meet the minimum operating limit in most applications.
- (5) Ceramic capacitors can be used to complement electrolytic types at the input bus by reducing high-frequency ripple current.

Designing for Load Transients

The transient response of the dc/dc converter has been characterized using a load transient with a di/dt of 1A/ μ s. The typical voltage deviation for this load transient is given in the data-sheet specification table using the optional value of output capacitance. As the di/dt of a transient is increased, the response of a converter's regulation circuit ultimately depends on its output capacitor decoupling network. This is an inherent limitation with any dc/dc converter once the speed of the transient exceeds its bandwidth capability. If the target application specifies a higher di/dt or lower voltage deviation, the requirement can only be met with additional output capacitor decoupling. In these cases, special attention must be paid to the type, value, and ESR of the capacitors selected.

If the transient performance requirements exceed those specified in the data sheet, the selection of output capacitors becomes more important. Review the minimum ESR in the characteristic data sheet for details on the capacitance maximum.

Features of the PTH/PTV Family of Nonisolated, Wide-Output Adjustable Power Modules

POLA™ Compatibility

The PTH/PTV family of nonisolated, wide-output adjustable power modules from Texas Instruments are optimized for applications that require a flexible, high-performance power module that is small in size. Each of these products are POLA™ compatible. POLA-compatible products are produced by a number of manufacturers, and offer customers advanced, nonisolated modules with the same footprint and form factor. POLA parts are also ensured to be interoperable, thereby providing customers with true second-source availability.

Soft-Start Power Up

The Auto-Track feature allows the power up of multiple PTH/PTV modules to be directly controlled from the Track pin. However, in a stand-alone configuration, or when the Auto-Track feature is not being used, the *Track* pin should be directly connected to the input voltage, V_I (see Figure 10).

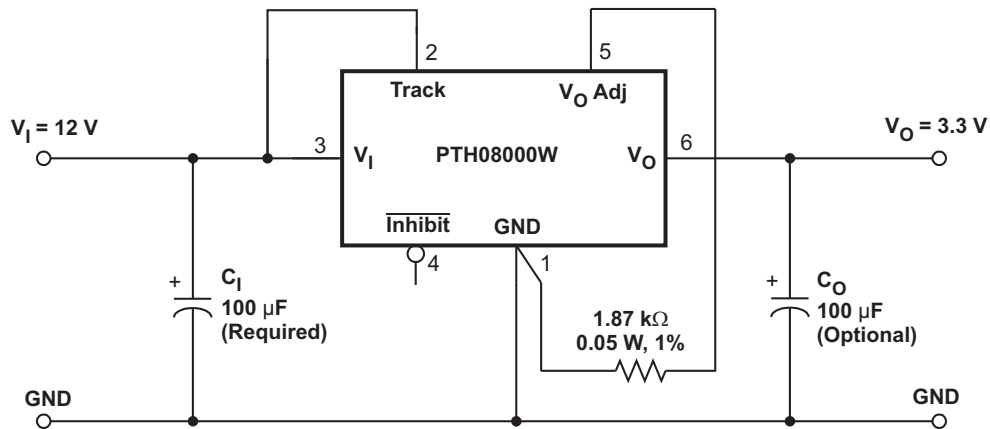

Figure 10. Power-Up Application Circuit

When the *Track* pin is connected to the input voltage, the Auto-Track function is permanently disengaged. This allows the module to power up entirely under the control of its internal soft-start circuitry. When power up is under soft-start control, the output voltage rises to the set-point at a quicker and more linear rate.

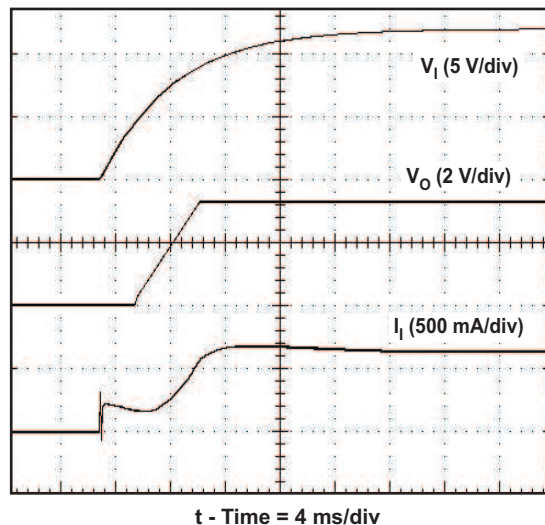

Figure 11. Power-Up Waveform

From the moment a valid input voltage is applied, the soft-start control introduces a short time delay (typically

less than 5 ms) before allowing the output voltage to rise. The output then progressively rises to the module set-point voltage. Figure 11 shows the soft-start power-up characteristic of the PTH08000W, operating from a 12-V input bus and configured for a 3.3-V output. The waveforms were measured with a 2-A resistive load and the Auto-Track feature disabled. The initial rise in input current when the input voltage first starts to rise is the charge current drawn by the input capacitors. Power up is complete within 25 ms.

Current Limit Protection

The PTH08000W modules protect against load faults with an output overcurrent trip. Under a load fault condition, the output current cannot exceed the current limit value. Attempting to draw current that exceeds the current limit value causes the output voltage to enter into a *hiccup* mode of operation, whereby the module continues in a cycle of successive shutdown and power up until the load fault is removed. On removal of the fault, the output voltage promptly recovers.

Thermal Shutdown

Thermal shutdown protects the module internal circuitry against excessively high temperatures. A rise in temperature may be the result of a drop in airflow, a high ambient temperature, or a higher than normal output current. If the junction temperature of the internal components exceeds 165°C, the module shuts down. This reduces the output voltage to zero. The module starts up automatically, by initiating a soft-start power up when the sensed temperature decreases 10°C below the thermal shutdown trip-point.

Output On/Off Inhibit

For applications requiring output voltage on/off control, the PTH08000 power module incorporates an output on/off Inhibit control (pin 4). The inhibit feature can be used wherever there is a requirement for the output voltage from the regulator to be turned off.

The power module functions normally when the Inhibit pin is left open-circuit, providing a regulated output whenever a valid source voltage is connected to V_I with respect to GND.

Figure 12 shows the typical application of the inhibit function. Note the discrete transistor (Q1). The Inhibit control has its own internal pull-up to 3 V. An open-collector or open-drain device is recommended to control this input. **Do not place an external pull-up on this pin.**

Turning Q1 on applies a low voltage to the *Inhibit* control pin and disables the output of the module. If Q1 is then turned off, the module executes a soft-start power-up sequence. A regulated output voltage is produced within 20 ms. Figure 13 shows the typical rise in the output voltage, following the turn off of Q1. The turn off of Q1 corresponds to the rise in the waveform, $Q1 V_{DS}$. The waveforms were measured with a 2-A resistive load.

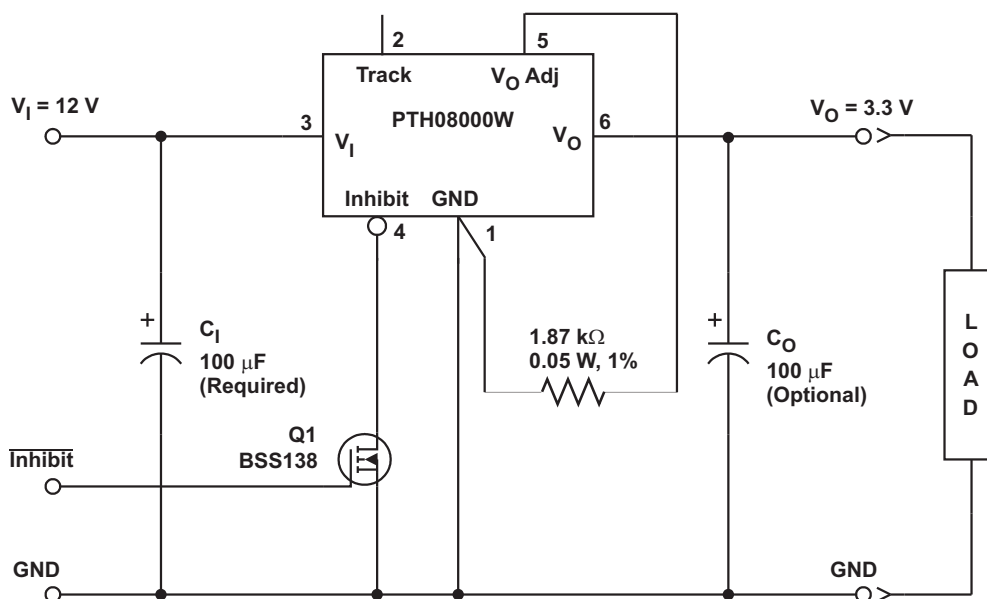

Figure 12. On/Off Inhibit Control Circuit

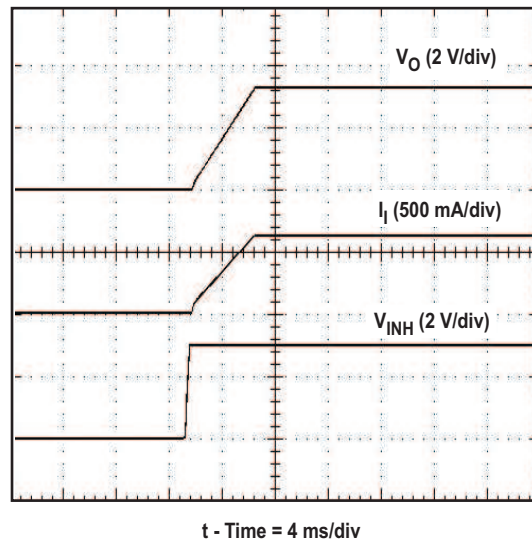

Figure 13. Power-Up Response From Inhibit Control

Auto-Track™ Function

The Auto-Track function is unique to the PTH/PTV family, and is available with all POLA products. Auto-Track was designed to simplify the amount of circuitry required to make the output voltage from each module power up and power down in sequence. The sequencing of two or more supply voltages during power up is a common requirement for complex mixed-signal applications that use dual-voltage VLSI ICs such as the TMS320™ DSP family, microprocessors, and ASICs.

How Auto-Track™ Works

Auto-Track works by forcing the module output voltage to follow a voltage presented at the *Track* control pin ⁽¹⁾. This control range is limited to between 0 V and the module set-point voltage. Once the track-pin voltage is raised above the set-point voltage, the module output remains at its set-point ⁽²⁾. As an example, if the *Track* pin of a 2.5-V regulator is at 1 V, the regulated output is 1 V. If the voltage at the *Track* pin rises to 3 V, the regulated output does not go higher than 2.5 V.

When under Auto-Track control, the regulated output from the module follows the voltage at its *Track* pin on a volt-for-volt basis. By connecting the *Track* pin of a number of these modules together, the output voltages follow a common signal during power up and power down. The control signal can be an externally generated master ramp waveform, or the output voltage from another power supply circuit ⁽³⁾. For convenience, the *Track* input incorporates an internal RC-charge circuit. This operates off the module input voltage to produce a suitable rising waveform at power up.

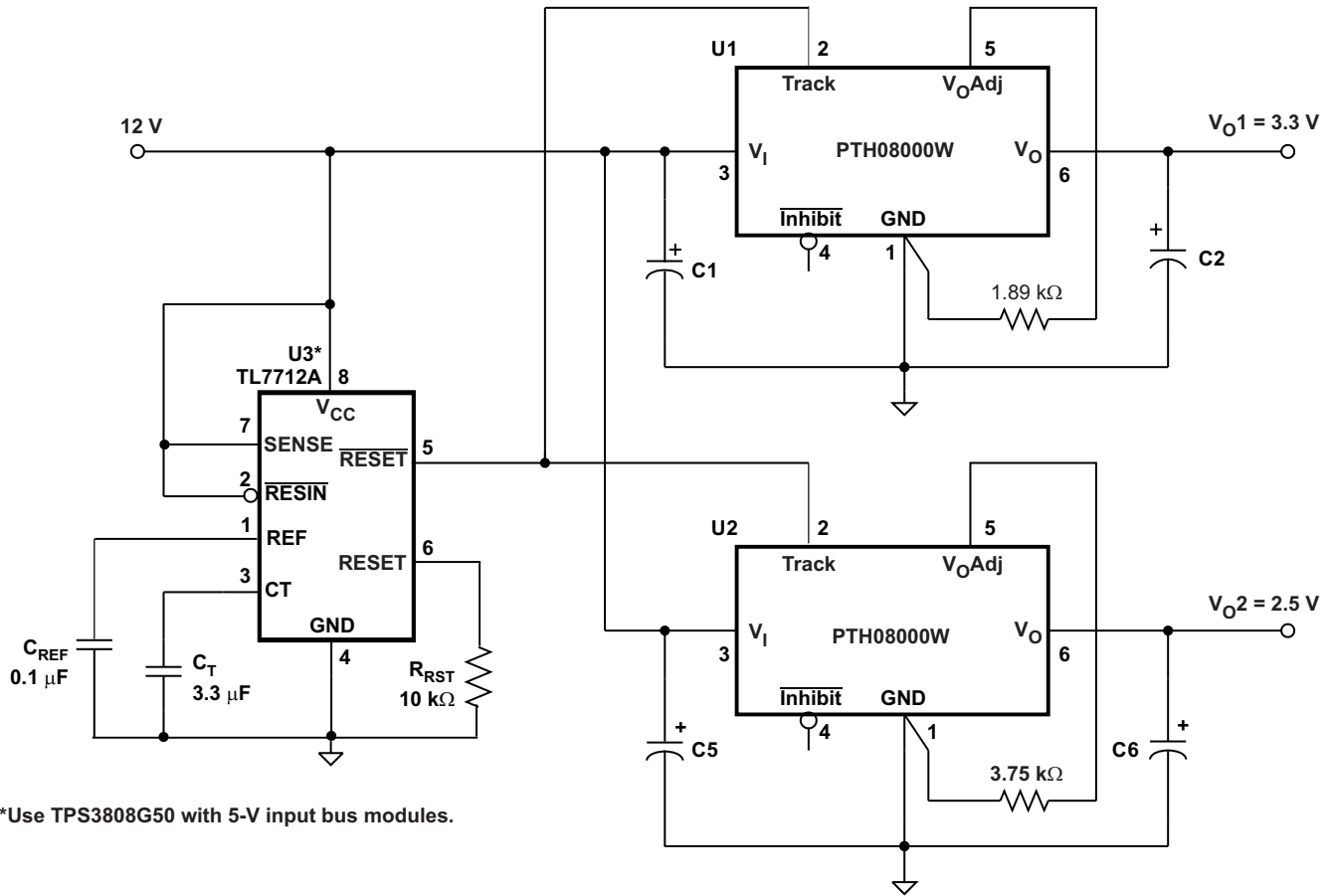

Figure 14. Auto-Track Circuit

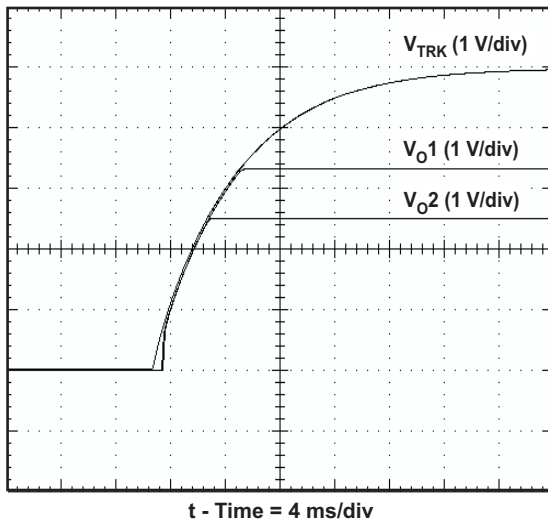

Figure 15. Simultaneous Power Up With Auto-Track Control

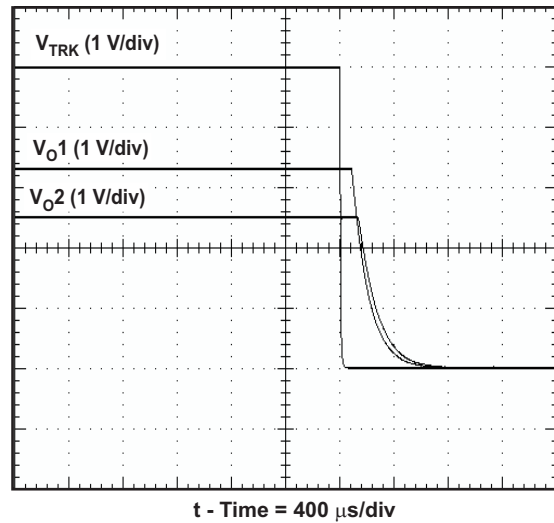

Figure 16. Simultaneous Power Down With Auto-Track Control

Typical Application

The basic implementation of Auto-Track allows for simultaneous voltage sequencing of a number of Auto-Track compliant modules. Connecting the *Track* inputs of two or more modules forces their track input to follow the same collective RC-ramp waveform, and allows their power-up sequence to be coordinated from a common Track control signal. This can be an open-collector (or open-drain) device, such as a power-up reset voltage supervisor IC. See U3 in [Figure 14](#).

To coordinate a power-up sequence, the Track control must first be pulled to ground potential. This should be done at or before input power is applied to the modules. The ground signal should be maintained for at least 20 ms after input power has been applied. This brief period gives the modules time to complete their internal soft-start initialization⁽⁴⁾, enabling them to produce an output voltage. A low-cost supply voltage supervisor IC, that includes a built-in time delay, is an ideal component for automatically controlling the Track inputs at power up.

[Figure 14](#) shows how the TPS3808G50 supply voltage supervisor IC (U3) can be used to coordinate the sequenced power up of two 5-V input Auto-Track modules. The output of the TPS3808G50 supervisor becomes active above an input voltage of 0.8 V, enabling it to assert a ground signal to the common track control well before the input voltage has reached the module's undervoltage lockout threshold. The ground signal is maintained until approximately 27 ms after the input voltage has risen above U3's voltage threshold, which is 4.65 V. The 27-ms time period is controlled by the capacitor C3. The value of 4700 pF provides sufficient time delay for the modules to complete their internal soft-start initialization. The output voltage of each module remains at zero until the track control voltage is allowed to rise. When U3 removes the ground signal, the track control voltage automatically rises. This causes the output voltage of each module to rise simultaneously with the other modules, until each reaches its respective set-point voltage.

[Figure 15](#) shows the output voltage waveforms from the circuit of [Figure 14](#) after input voltage is applied to the circuit. The waveforms, V_{O1} and V_{O2} , represent the output voltages from the two power modules, U1 (3.3 V) and U2 (2.5 V), respectively. V_{O1} and V_{O2} are shown rising together to produce the desired simultaneous power-up characteristic.

The same circuit also provides a power-down sequence. When the input voltage falls below U3's voltage threshold, the ground signal is re-applied to the common track control. This pulls the track inputs to zero volts, forcing the output of each module to follow. Power down is normally complete before the input voltage has fallen below the modules' undervoltage lockout. This is an important constraint. Once the modules recognize that an input voltage is no longer present, their outputs can no longer follow the voltage applied at their track input. During a power-down sequence, the fall in the output voltage from the modules is limited by the Auto-Track slew rate capability.

Notes on Use of Auto-Track™

1. The *Track* pin voltage must be allowed to rise above the module set-point voltage before the module regulates at its adjusted set-point voltage.
2. The Auto-Track function tracks almost any voltage ramp during power up, and is compatible with ramp speeds of up to 1 V/ms.
3. The absolute maximum voltage that may be applied to the *Track* pin is the input voltage V_I .
4. The module cannot follow a voltage at its track control input until it has completed its soft-start initialization. This takes about 20 ms from the time that a valid voltage has been applied to its input. During this period, it is recommended that the *Track* pin be held at ground potential.
5. The Auto-Track function is disabled by connecting the *Track* pin to the input voltage (V_I). When Auto-Track is disabled, the output voltage rises at a quicker and more linear rate after input power has been applied.

PACKAGING INFORMATION

Orderable Device	Status (1)	Package Type	Package Drawing	Pins	Package Qty	Eco Plan (2)	Lead/Ball Finish (6)	MSL Peak Temp (3)	Op Temp (°C)	Device Marking (4/5)	Samples
PTH08000WAH	ACTIVE	Through-Hole Module	EUS	6	56	RoHS Exempt & Green	SN	N / A for Pkg Type	-40 to 85		Samples
PTH08000WAS	ACTIVE	Surface Mount Module	EUT	6	49	RoHS (In Work) & Green (In Work)	SNPB	Level-1-235C-UNLIM/ Level-3-260C-168HRS	-40 to 85		Samples
PTH08000WAST	ACTIVE	Surface Mount Module	EUT	6	250	RoHS (In Work) & Green (In Work)	SNPB	Level-1-235C-UNLIM/ Level-3-260C-168HRS	-40 to 85		Samples
PTH08000WAZ	ACTIVE	Surface Mount Module	EUT	6	49	RoHS (In Work) & Green (In Work)	SNAGCU	Level-3-260C-168 HR	-40 to 85		Samples
PTH08000WAZT	ACTIVE	Surface Mount Module	EUT	6	250	RoHS (In Work) & Green (In Work)	SNAGCU	Level-3-260C-168 HR	-40 to 85		Samples

(1) The marketing status values are defined as follows:

ACTIVE: Product device recommended for new designs.

LIFEBUY: TI has announced that the device will be discontinued, and a lifetime-buy period is in effect.

NRND: Not recommended for new designs. Device is in production to support existing customers, but TI does not recommend using this part in a new design.

PREVIEW: Device has been announced but is not in production. Samples may or may not be available.

OBSOLETE: TI has discontinued the production of the device.

(2) **RoHS:** TI defines "RoHS" to mean semiconductor products that are compliant with the current EU RoHS requirements for all 10 RoHS substances, including the requirement that RoHS substance do not exceed 0.1% by weight in homogeneous materials. Where designed to be soldered at high temperatures, "RoHS" products are suitable for use in specified lead-free processes. TI may reference these types of products as "Pb-Free".

RoHS Exempt: TI defines "RoHS Exempt" to mean products that contain lead but are compliant with EU RoHS pursuant to a specific EU RoHS exemption.

Green: TI defines "Green" to mean the content of Chlorine (Cl) and Bromine (Br) based flame retardants meet JS709B low halogen requirements of <=1000ppm threshold. Antimony trioxide based flame retardants must also meet the <=1000ppm threshold requirement.

(3) MSL, Peak Temp. - The Moisture Sensitivity Level rating according to the JEDEC industry standard classifications, and peak solder temperature.

(4) There may be additional marking, which relates to the logo, the lot trace code information, or the environmental category on the device.

(5) Multiple Device Markings will be inside parentheses. Only one Device Marking contained in parentheses and separated by a "~" will appear on a device. If a line is indented then it is a continuation of the previous line and the two combined represent the entire Device Marking for that device.

⁽⁶⁾ Lead/Ball Finish - Orderable Devices may have multiple material finish options. Finish options are separated by a vertical ruled line. Lead/Ball Finish values may wrap to two lines if the finish value exceeds the maximum column width.

Important Information and Disclaimer:The information provided on this page represents TI's knowledge and belief as of the date that it is provided. TI bases its knowledge and belief on information provided by third parties, and makes no representation or warranty as to the accuracy of such information. Efforts are underway to better integrate information from third parties. TI has taken and continues to take reasonable steps to provide representative and accurate information but may not have conducted destructive testing or chemical analysis on incoming materials and chemicals. TI and TI suppliers consider certain information to be proprietary, and thus CAS numbers and other limited information may not be available for release.

In no event shall TI's liability arising out of such information exceed the total purchase price of the TI part(s) at issue in this document sold by TI to Customer on an annual basis.

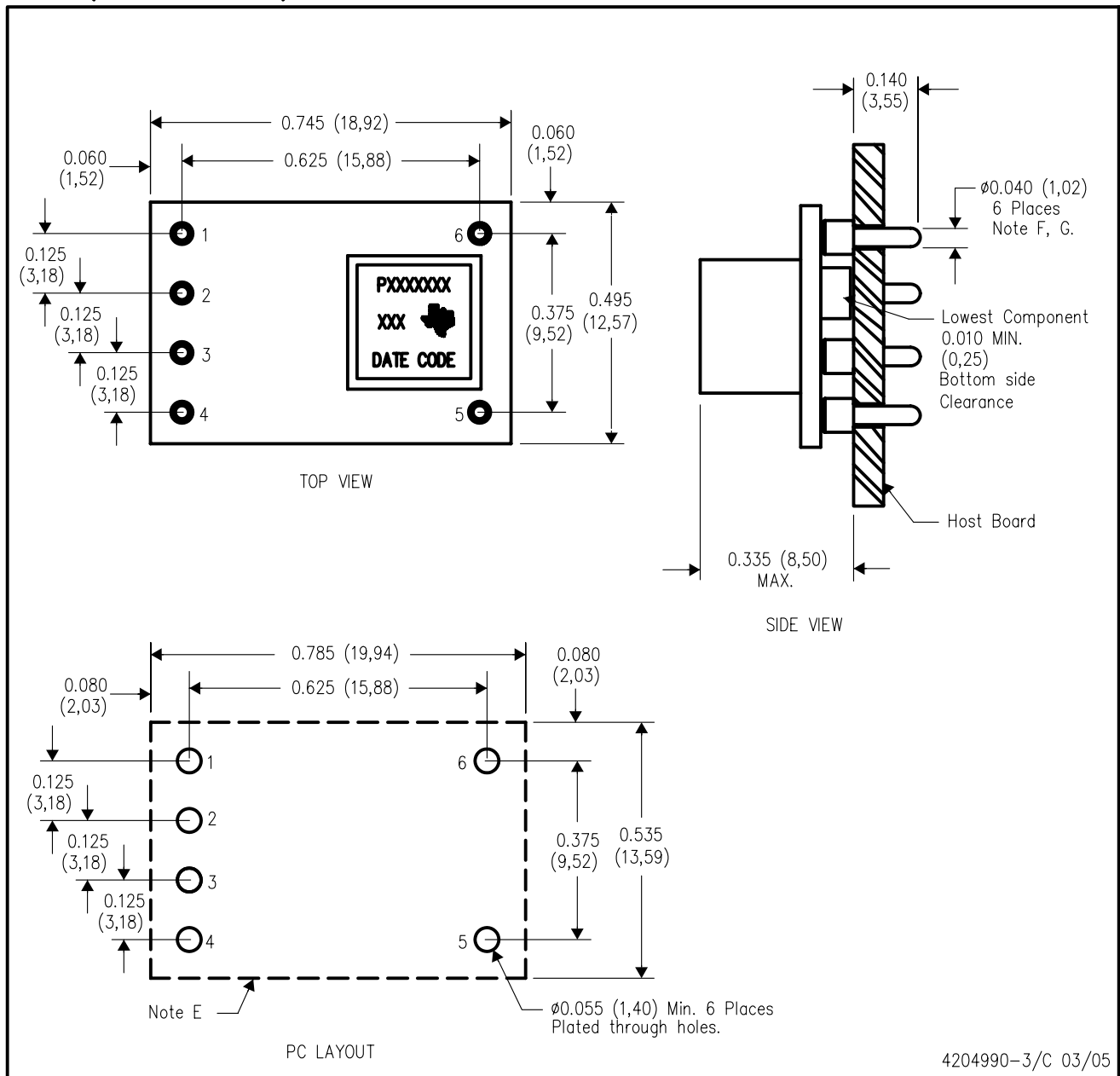

4204990-3/C 03/05

- NOTES:
- A. All linear dimensions are in inches (mm).
 - B. This drawing is subject to change without notice.
 - C. 2 place decimals are ± 0.030 ($\pm 0,76$ mm).
 - D. 3 place decimals are ± 0.010 ($\pm 0,25$ mm).
 - E. Recommended keep out area for user components.

- F. Pins are 0.040" (1,02) diameter with 0.070" (1,78) diameter standoff shoulder.
- G. All pins: Material - Copper Alloy
Finish - Tin (100%) over Nickel plate

IMPORTANT NOTICE AND DISCLAIMER

TI PROVIDES TECHNICAL AND RELIABILITY DATA (INCLUDING DATASHEETS), DESIGN RESOURCES (INCLUDING REFERENCE DESIGNS), APPLICATION OR OTHER DESIGN ADVICE, WEB TOOLS, SAFETY INFORMATION, AND OTHER RESOURCES "AS IS" AND WITH ALL FAULTS, AND DISCLAIMS ALL WARRANTIES, EXPRESS AND IMPLIED, INCLUDING WITHOUT LIMITATION ANY IMPLIED WARRANTIES OF MERCHANTABILITY, FITNESS FOR A PARTICULAR PURPOSE OR NON-INFRINGEMENT OF THIRD PARTY INTELLECTUAL PROPERTY RIGHTS.

These resources are intended for skilled developers designing with TI products. You are solely responsible for (1) selecting the appropriate TI products for your application, (2) designing, validating and testing your application, and (3) ensuring your application meets applicable standards, and any other safety, security, or other requirements. These resources are subject to change without notice. TI grants you permission to use these resources only for development of an application that uses the TI products described in the resource. Other reproduction and display of these resources is prohibited. No license is granted to any other TI intellectual property right or to any third party intellectual property right. TI disclaims responsibility for, and you will fully indemnify TI and its representatives against, any claims, damages, costs, losses, and liabilities arising out of your use of these resources.

TI's products are provided subject to TI's Terms of Sale (www.ti.com/legal/termsofsale.html) or other applicable terms available either on ti.com or provided in conjunction with such TI products. TI's provision of these resources does not expand or otherwise alter TI's applicable warranties or warranty disclaimers for TI products.

Mailing Address: Texas Instruments, Post Office Box 655303, Dallas, Texas 75265
Copyright © 2018, Texas Instruments Incorporated

Looking for pricing, stock, or lifecycle information?

Click below to explore more details on WIN SOURCE:

 [View PTH08000WAZT on WIN SOURCE](#)

 [Texas Instruments](#) Information

Optimize Your Supply Chain with WIN SOURCE Solutions

-  Global Sourcing Solution
-  Obsolete Management
-  Cost Control Management
-  Shortage Management
-  Alternative Solution
-  Excess Inventory Management