



**THE DATASHEET OF
PT67-21C/L41/TR8**



Technical Data Sheet Top Phototransistor PT67-21C/L41/TR8

Features

- Fast response time
- High photo sensitivity
- Small junction capacitance
- Compatible with infrared and vapor phase reflow solder process.
- Pb free
- The product itself will remain within RoHS compliant version.



Description

- PT67-21C/L41/TR8 is a high speed silicon NPN epitaxial planar phototransistor in a compact surface-mountable package. It's compatible with automatic placement equipment and can withstand IR reflow, vapor phase reflow , and wave solder processes.

Applications

- Miniature switch
- Counters and sorter
- Position sensor
- Infrared applied system
- Encoder

Device Selection Guide

Device No.	Chip Material	Lens Color
PT67-21C/L41/TR8	Silicon	Water clear

Package Dimensions

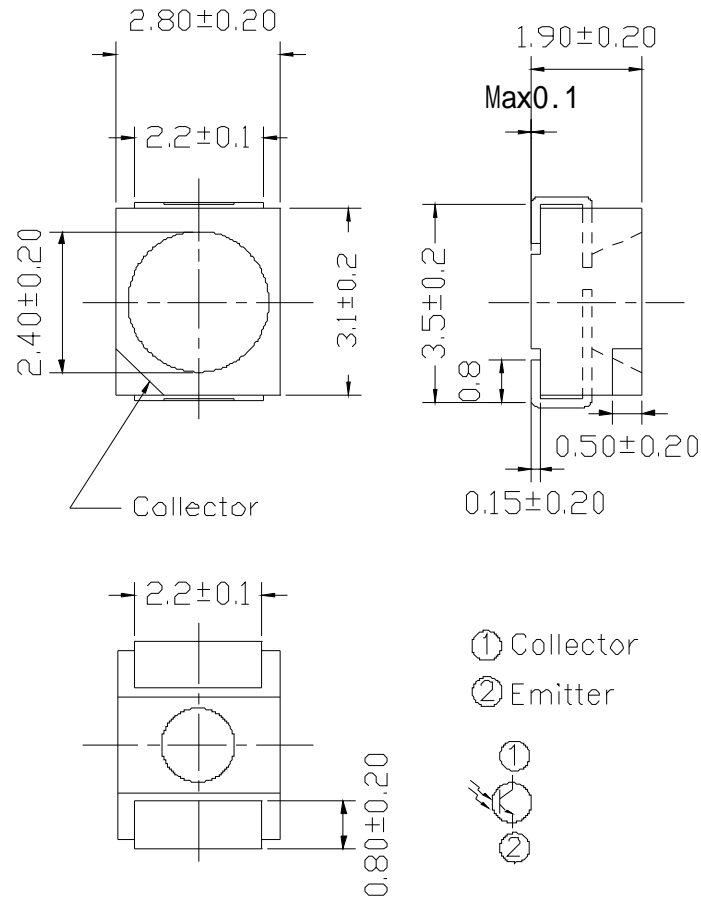

Absolute Maximum Ratings ($T_a=25^\circ\text{C}$)

Parameter	Symbol	Rating	Unit
Collector-Emitter Voltage	V_{CEO}	30	V
Emitter-Collector-Voltage	V_{ECO}	5	V
Collector Current	I_C	20	mA
Operating Temperature	T_{opr}	-25 ~ +85	
Storage Temperature	T_{stg}	-40 ~ +85	
Soldering Temperature	T_{sol}	260	
Power Dissipation at(or below) 25 Free Air Temperature	P_c	75	mW

Notes: *1:Soldering time 5 seconds.

Electro-Optical Characteristics (Ta=25)

Parameter	Symbol	Min.	Typ.	Max.	Unit	Condition
Rang Of Spectral Bandwidth	0.5	400	---	1100	nm	---
Wavelength Of Peak Sensitivity	P	---	940	---	nm	---
Collector-Emitter Breakdown Voltage	BV _{CEO}	30	---	---	V	I _C =100 μ A Ee=0mW/cm ²
Emitter-Collector Breakdown Voltage	BV _{ECO}	5	---	---	V	I _E =100 μ A Ee=0mW/cm ²
Collector-Emitter Saturation Voltage	V _{CE(sat)}	---	---	0.4	V	I _C =2mA Ee=1mW/cm ²
Collector Dark Current	I _{CEO}	---	---	100	nA	V _{CE} =20V Ee=0mW/cm ²
On State Collector Current	I _{C(ON)}	0.3	1.0	---	mA	V _{CE} =5V Ee=1mW/cm ²
Rise Time	t _r	---	15	---	μ S	V _{CE} =5V I _C =1mA R _L =1000
Fall Time	t _f	---	15	---		

Typical Electrical/Optical/Characteristics Curves for IR

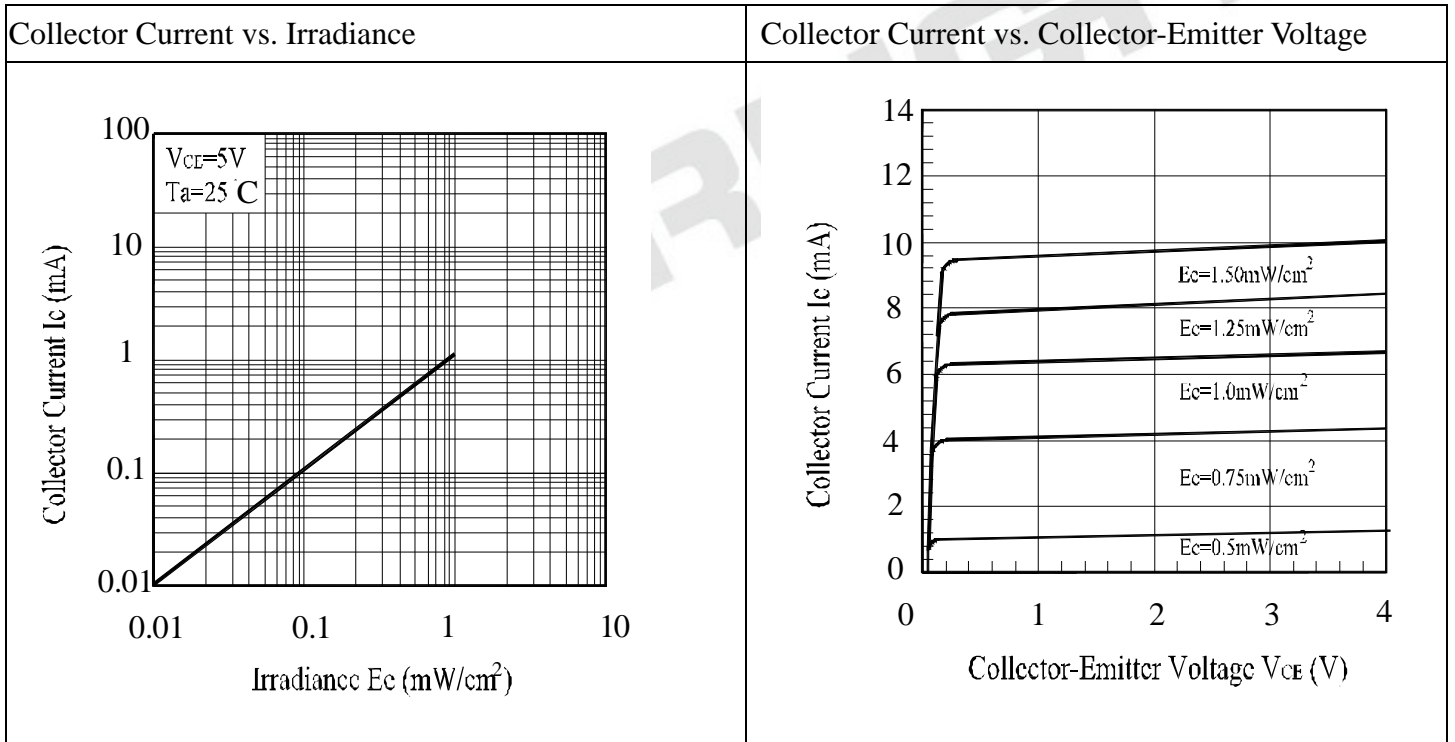
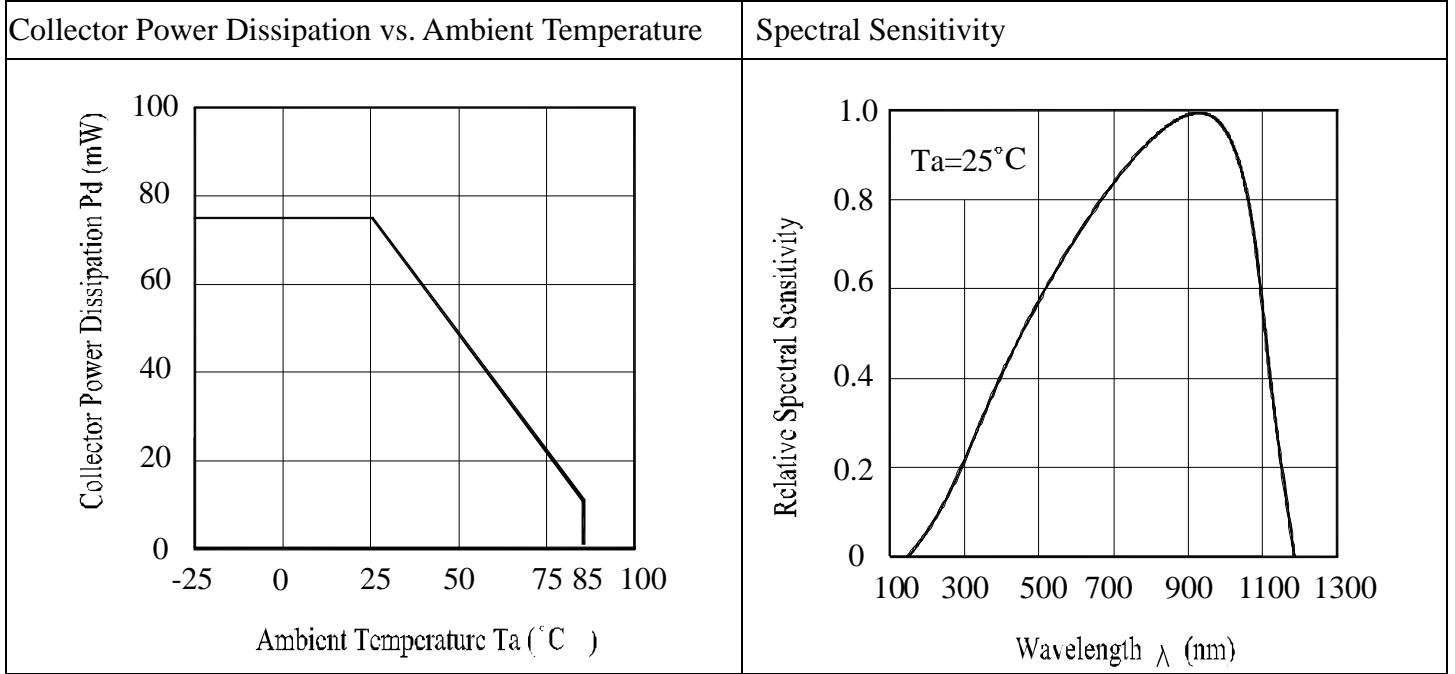

● **Precautions For Use**

1. Over-current-proof

Customer must apply resistors for protection , otherwise slight voltage shift will cause big current change (Burn out will happen).

2. Storage

- 2.1 Do not open moisture proof bag before the products are ready to use.
- 2.2 Shelf life in sealed bag from the bag seal date: 12 months at < 40°C and < 90% RH.
- 2.3 After opening the package, the LEDs must be kept at ≤ 30°C and ≤ 60%RH, and used within a year.
- 2.4 If the moisture absorbent material (silica gel) has faded away or the LEDs have exceeded the storage time. Baking treatment is required, refer to IPC/JEDEC J-STD-033 for bake procedure or recommend the conditions : 60±5°C for 48 hours.

3. Soldering Condition

3.1 Pb-free solder temperature profile

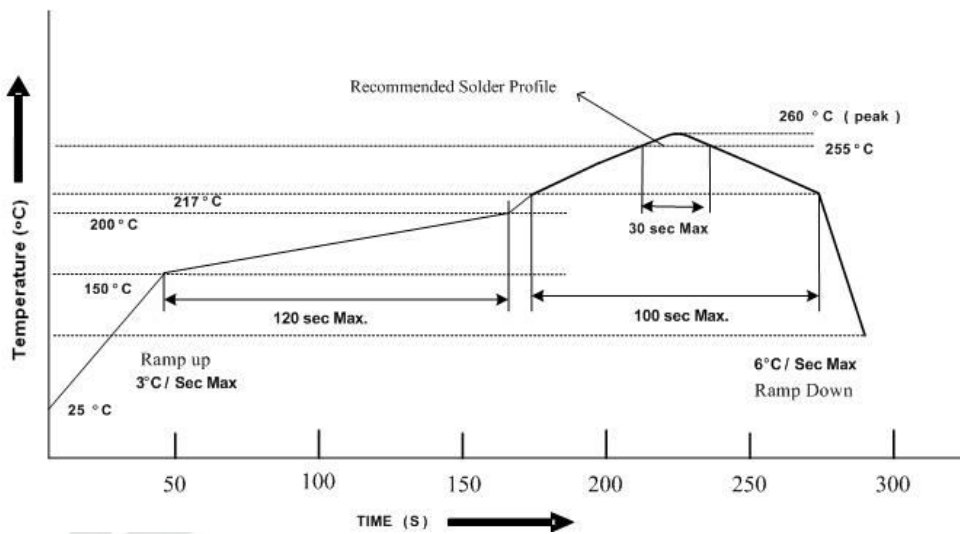

- 3.2 Reflow soldering should not be done more than two times.
- 3.3 When soldering, do not put stress on the LEDs during heating.
- 3.4 After soldering, do not warp the circuit board.

4. Soldering Iron

Each terminal is to go to the tip of soldering iron temperature less than 350 for 3 seconds within once in less than the soldering iron capacity 25W. Leave two seconds and more intervals, and do soldering of each terminal. Be careful because the damage of the product is often started at the time of the hand solder.

5. Repairing

Repair should not be done after the LEDs have been soldered. When repairing is unavoidable, a double-head soldering iron should be used (as below figure). It should be confirmed beforehand whether the characteristics of the LEDs will or will not be damaged by repairing.

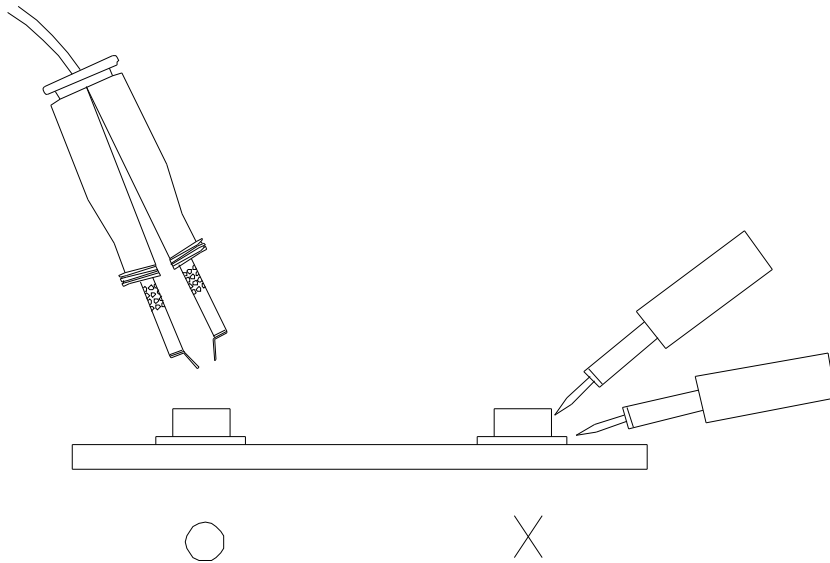

Packing Procedure

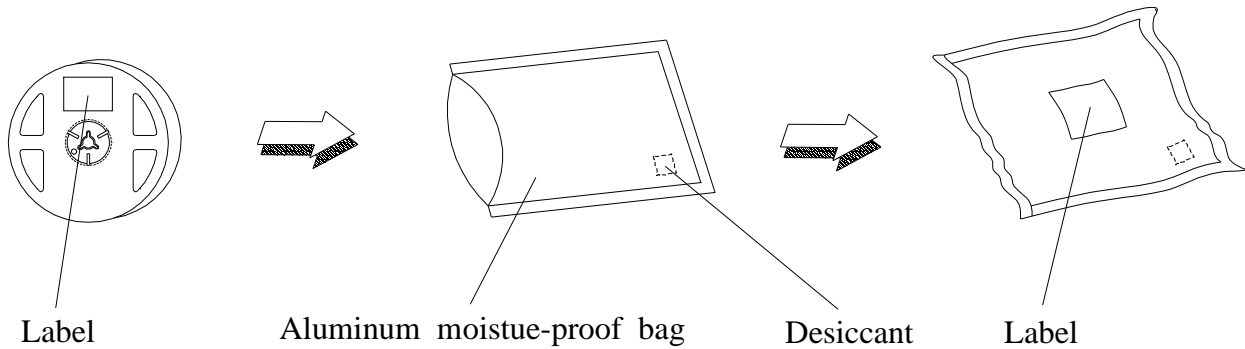

Label Form Specification

	EVERLIGHT	
CPN : P/N : XXXXXXXXXXXXX XXXXXXXXXXXXXX		RoHS
QTY : XXX XXXXXXXXXXXXXX	CAT : XXX HUE : XXX REF : XXX	
LOT NO : XXXXXXXXXXXX XXXXXXXXXXXXXX		
Reference : XXXXXXXX XXXXXXXXXXXXXX		

CPN: Customer's Production Number
P/N : Production Number
QTY: Packing Quantity
CAT: Ranks
HUE: Peak Wavelength
REF: Reference
LOT No: Lot Number
MADE IN TAIWAN: Production Place

Notes

1. Above specification may be changed without notice. EVERLIGHT will reserve authority on material change for above specification.
2. When using this product, please observe the absolute maximum ratings and the instructions for using outlined in these specification sheets. EVERLIGHT assumes no responsibility for any damage resulting from use of the product which does not comply with the absolute maximum ratings and the instructions included in these specification sheets.
3. These specification sheets include materials protected under copyright of EVERLIGHT corporation. Please don't reproduce or cause anyone to reproduce them without EVERLIGHT's consent.

EVERLIGHT ELECTRONICS CO., LTD.
Office: No 6-8, Zhonghua Rd., Shulin Dist.,
New Taipei City 23860, Taiwan, R.O.C

Tel: 886-2-2685-6688
Fax: 886-2-2685-6699
<http://www.everlight.com>

Looking for pricing, stock, or lifecycle information?

Click below to explore more details on WIN SOURCE:

- [View PT67-21C/L41/TR8 on WIN SOURCE](#)
- [Everlight Electronics Co Ltd Information](#)

Optimize Your Supply Chain with WIN SOURCE Solutions

- ✓ Global Sourcing Solution
- ✓ Obsolete Management
- ✓ Cost Control Management
- ✓ Shortage Management
- ✓ Alternative Solution
- ✓ Excess Inventory Management