



# THE DATASHEET OF PM6600





## PM6600

### 6-row 32 mA LED driver with boost regulator for LCD panel backlight

#### Features

- Boost section
  - 4.7 V to 28 V input voltage range
  - Internal power MOSFET
  - Internal +5 V LDO for device supply
  - Up to 36 V output voltage
  - Constant frequency peak current-mode control
  - 200 kHz to 1 MHz adjustable switching frequency
  - External synchronization for multi-device application
  - Pulse-skip power saving mode at light load
  - Programmable soft-start
  - Programmable OVP protection
  - Stable with ceramic output capacitors
  - Thermal shutdown
- Backlight driver section
  - Six rows with 32 mA maximum current capability (adjustable)
  - Up to 10 WLEDs per row
  - Unused rows detection
  - 500 ns minimum dimming time (1% minimum dimming duty-cycle at 20 kHz)
  - $\pm 2.1\%$  current accuracy
  - $\pm 2\%$  current matching between rows
  - LED failure (open and short circuit) detection

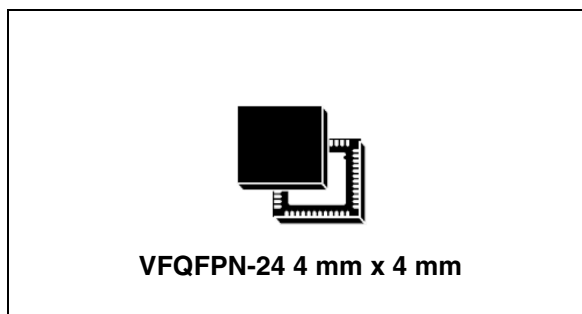

#### Description

The PM6600 consists of a high efficiency monolithic boost converter and six controlled current generators (ROWS), specifically designed to supply LEDs arrays used in the backlight of LCD panels. The device can manage a nominal output voltage up to 36 V (i.e. 10 White-LEDs per ROW). The generators can be externally programmed to sink up to 32 mA and they can be dimmed via a PWM signal (1% dimming duty-cycle at 20 kHz can be managed). The device allows to detect and manage the open and shorted LED faults and to let unused ROWs floating. Basic protections (output over-voltage, internal MOSFET over-current and thermal shutdown) are provided.

#### Applications

- Notebook monitors backlight
- UMPC backlight

Table 1. Device summary

Order codes	Package	Packaging
PM6600	VFQFPN-24 4 mm x 4 mm (exposed pad)	Tube
PM6600TR		Tape and reel

# Contents

- 1      Typical application circuit ..... 7**
- 2      Pin settings ..... 8**
  - 2.1    Connections ..... 8
  - 2.2    Pin description ..... 8
- 3      Electrical data ..... 10**
  - 3.1    Maximum rating ..... 10
  - 3.2    Thermal data ..... 10
  - 3.3    Recommended operating conditions ..... 11
- 4      Electrical characteristics ..... 12**
- 5      Typical operating characteristics ..... 15**
- 6      Block diagram ..... 25**
- 7      Operation description ..... 26**
  - 7.1    Boost section ..... 26
    - 7.1.1    Functional description ..... 26
  - 7.2    Overvoltage protection ..... 27
  - 7.3    Switching frequency selection and synchronization ..... 28
  - 7.4    System stability ..... 30
    - 7.4.1    Loop compensation ..... 30
    - 7.4.2    Slope compensation ..... 32
  - 7.5    Soft-start ..... 33
  - 7.6    Boost current limit ..... 35
  - 7.7    Enable function ..... 35
  - 7.8    Thermal protection ..... 36
- 8      Backlight driver section ..... 37**
  - 8.1    Current generators ..... 37
  - 8.2    PWM dimming ..... 38

<b>9</b>	<b>Fault management</b> .....	<b>39</b>
9.1	FAULT pin .....	39
9.2	MODE pin .....	39
9.3	Open LED fault .....	40
9.4	Shorted LED fault .....	40
9.5	Intermittent connection .....	40
<b>10</b>	<b>Package mechanical data</b> .....	<b>42</b>
<b>Appendix A</b>	<b>Layout guidelines</b> .....	<b>44</b>
A.1	Basic points: .....	44
A.1.1	GNDs planes - 1 device .....	44
A.1.2	GNDs planes - 3 devices (RGB) .....	44
A.2	Compensation network .....	44
A.3	LX area – vout power area .....	45
A.4	Overvoltage divider .....	45
A.5	LDO5 – AVCC filter .....	45
A.6	ROWS current generators .....	45
A.7	Top layer of the standard PM6600 demonstration board. ....	46
<b>Appendix B</b>	<b>Application note</b> .....	<b>48</b>
B.1	Inductor selection .....	48
B.2	Capacitors selection .....	48
B.3	Flywheel diode selection .....	48
B.4	Design example. ....	49
B.4.1	Switching frequency setting .....	49
B.4.2	Row current setting .....	49
B.4.3	Inductor choice .....	49
B.4.4	Output capacitor choice .....	51
B.4.5	Input capacitor choice .....	52
B.4.6	Overvoltage protection divider setting. ....	52
B.4.7	Compensation network .....	53
B.4.8	Boost current limit .....	53
B.4.9	Soft-start .....	54

---

<b>Appendix C</b>	<b>Application suggestions</b> .....	<b>55</b>
C.1	Full application schematic .....	55
C.2	EN, DIM path in production line .....	56
C.3	ROW pins protection .....	57
C.4	Debug and measurements test points .....	57
C.5	Inductor choice .....	58
<b>11</b>	<b>Revision history</b> .....	<b>59</b>

## List of figures

Figure 1.	Application circuit	7
Figure 2.	Pin connection (through top view)	8
Figure 3.	Efficiency vs DIM duty cycle @ fDIM = 200 Hz.	15
Figure 4.	Efficiency vs DIM duty cycle @ fDIM = 500 Hz.	15
Figure 5.	Efficiency vs DIM duty cycle @ fDIM = 1 kHz.	15
Figure 6.	Efficiency vs DIM duty cycle @ fDIM = 5 kHz.	15
Figure 7.	Efficiency vs DIM duty cycle @ fDIM = 10 kHz.	16
Figure 8.	Efficiency vs DIM duty cycle @ fDIM = 20 kHz.	16
Figure 9.	Efficiency vs DIM duty cycle @ Vin = 8 V.	16
Figure 10.	Efficiency vs DIM duty cycle @ Vin = 12 V.	16
Figure 11.	Efficiency vs DIM duty cycle @ Vin = 18 V.	16
Figure 12.	Efficiency vs DIM duty cycle @ Vin = 24 V.	16
Figure 13.	Efficiency vs Vin @ DIM duty cycles = 10%	17
Figure 14.	Efficiency vs Vin @ DIM duty cycles = 50%	17
Figure 15.	Efficiency vs Vin @ DIM duty cycles = 75%	17
Figure 16.	Efficiency vs Vin @ DIM duty cycles = 100%	17
Figure 17.	Working waveforms @ fDIM = 100 Hz, D = 1%	18
Figure 18.	Working waveforms @ fDIM = 100 Hz, D = 10%	18
Figure 19.	Working waveforms @ fDIM = 100 Hz, D = 50%	18
Figure 20.	Working waveforms @ fDIM = 100 Hz, D = 80%	18
Figure 21.	Working waveforms @ fDIM = 200 Hz, D = 1%	19
Figure 22.	Working waveforms @ fDIM = 200 Hz, D = 20%	19
Figure 23.	Working waveforms @ fDIM = 200 Hz, D = 50%	19
Figure 24.	Working waveforms @ fDIM = 200 Hz, D = 80%	19
Figure 25.	Working waveforms @ fDIM = 500 Hz, D = 1%	20
Figure 26.	Working waveforms @ fDIM = 500 Hz, D = 50%	20
Figure 27.	Working waveforms @ fDIM = 1 kHz, D = 1%	20
Figure 28.	Working waveforms @ fDIM = 1 kHz, D = 50%	20
Figure 29.	Working waveforms @ fDIM = 10 kHz, D = 1%	21
Figure 30.	Working waveforms @ fDIM = 10 kHz, D = 50%	21
Figure 31.	Working waveforms @ fDIM = 20 kHz, D = 1%	21
Figure 32.	Working waveforms @ fDIM = 20 Hz, D = 50%	21
Figure 33.	Output voltage ripple @ fDIM = 200 Hz, D = 1%	22
Figure 34.	Output voltage ripple @ fDIM = 200 Hz, D = 20%	22
Figure 35.	Output voltage ripple @ fDIM = 200 Hz, D = 50%	22
Figure 36.	Output voltage ripple @ fDIM = 200 Hz, D = 80%	22
Figure 37.	Shorted LED protection @ fDIM = 200 Hz all WLEDs connected	23
Figure 38.	Shorted LED protection @ fDIM = 200 Hz 1 WLED shorted	23
Figure 39.	Shorted LED protection @ fDIM = 200 Hz 2 WLEDs shorted.	23
Figure 40.	Shorted LED protection @ fDIM = 200 Hz 3 WLEDs shorted - ROW disabled	23
Figure 41.	Open ROW detection @ fDIM = 200 Hz.	24
Figure 42.	Simplified block diagram.	25
Figure 43.	AVCC filtering	26
Figure 44.	OVP threshold setting	28
Figure 45.	Multiple device synchronization	28
Figure 46.	External sync waveforms	29
Figure 47.	Poor phase margin (a) and properly damped (b) load transient responses	31
Figure 48.	Load transient response measurement set-up	32

---

Figure 49.	Main loop and current loop diagram . . . . .	32
Figure 50.	Effect of slope compensation on small inductor current perturbation ( $D > 0.5$ ) . . . . .	33
Figure 51.	Soft-start sequence waveforms in case of floating ROWs . . . . .	34
Figure 52.	fDIM enabling schematic . . . . .	36
Figure 53.	VFQFPN-24 mechanical data . . . . .	43
Figure 54.	Top layer critical signals components assembly and layout . . . . .	46
Figure 55.	Top side . . . . .	47
Figure 56.	Bottom side . . . . .	47
Figure 57.	Inductor current in DCM operation . . . . .	50
Figure 58.	Full application schematic. . . . .	55
Figure 59.	EN pin filter . . . . .	56
Figure 60.	DIM pin filter . . . . .	56
Figure 61.	ROW pins protection. . . . .	57

# 1 Typical application circuit

Figure 1. Application circuit

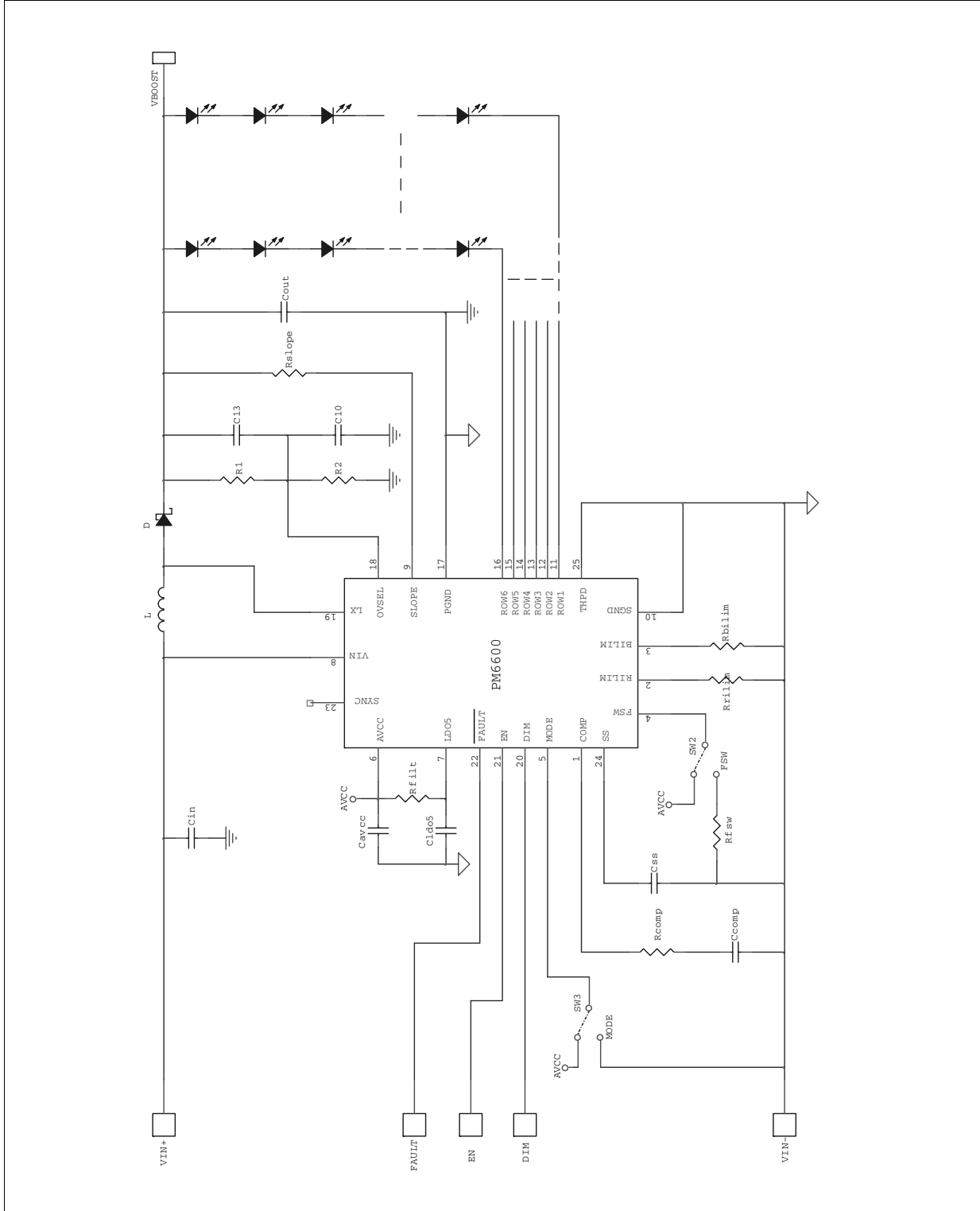

## 2 Pin settings

### 2.1 Connections

Figure 2. Pin connection (through top view)

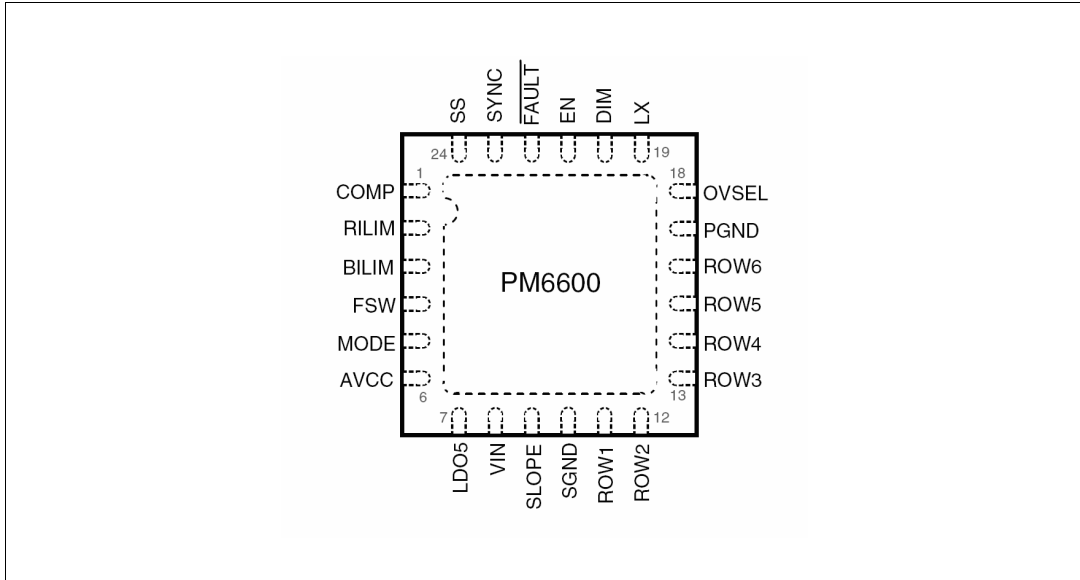

### 2.2 Pin description

Table 2. Pin functions

N°	Pin	Function
1	COMP	Error amplifier output. A simple RC series between this pin and ground is needed to compensate the loop of the boost regulator.
2	RILIM	Output generators current limit setting. The output current of the ROWs can be programmed connecting a resistor to SGND.
3	BILIM	Boost converter current limit setting. The internal MOSFET current limit can be programmed connecting a resistor to SGND.
4	FSW	Switching frequency selection and external sync input. A resistor to SGND is used to set the desired switching frequency. The pin can also be used as external synchronization input. See <a href="#">Section 7.3 on page 28</a> for details.
5	MODE	Current generators fault management selector. It allows to detect and manage LEDs failures. See <a href="#">Section 9.2 on page 39</a> for details.
6	AVCC	+5 V analog supply. Connect to LDO5 through a simple RC filter.
7	LDO5	Internal +5 V LDO output and power section supply. Bypass to SGND with a 1 $\mu$ F ceramic capacitor.
8	VIN	Input voltage. Connect to the main supply rail.

**Table 2. Pin functions (continued)**

N°	Pin	Function
9	SLOPE	Slope compensation setting. A resistor between the output of the boost converter and this pin is needed to avoid sub-harmonic instability. Refer to section 1.4 for details.
10	SGND	Signal ground. Supply return for the analog circuitry and the current generators.
11	ROW1	Row driver output #1.
12	ROW2	Row driver output #2.
13	ROW3	Row driver output #3.
14	ROW4	Row driver output #4.
15	ROW5	Row driver output #5.
16	ROW6	Row driver output #6.
17	PGND	Power ground. Source of the internal power-MOSFET.
18	OVSEL	Over-voltage selection. Used to set the desired OV threshold by an external divider. See <a href="#">Section 7.2 on page 27</a> for details.
19	LX	Switching node. Drain of the internal power-MOSFET.
20	DIM	Dimming input. Used to externally set the brightness of the LEDs by using a PWM signal.
21	EN	Enable input. When low, the device is turned off. If tied high or left floating, the device is turned on and a soft-start sequence takes place.
22	FAULT	Fault signal output. Open drain output. The pin goes low when a fault condition is detected (see <a href="#">Section 9.1 on page 39</a> for details).
23	SYNC	Synchronization output. Used as external synchronization output.
24	SS	Soft-start. Connect a capacitor to SGND to set the desired soft-start duration.

### 3 Electrical data

#### 3.1 Maximum rating

**Table 3. Absolute maximum ratings <sup>(1)</sup>**

Symbol	Parameter	Value	Unit
V <sub>AVCC</sub>	AVCC to SGND	-0.3 to 6	V
V <sub>LDO5</sub>	LDO5 to SGND	-0.3 to 6	
	PGND to SGND	-0.3 to 0.3	
V <sub>IN</sub>	VIN to PGND	-0.3 to 40	
V <sub>LX</sub>	LX to SGND	-0.3 to 40	
	LX to PGND	-0.3 to 40	
	RILIM, BILIM, SYNC, OVSEL, SS to SGND	-0.3 to V <sub>AVCC</sub> + 0.3	
	EN, DIM, FSW, MODE, FAULT to SGND	-0.3 to 6	
	ROWx to PGND/ SGND	-0.3 to 40	
	SLOPE to VIN	V <sub>IN</sub> - 0.3 to V <sub>IN</sub> + 6	
	SLOPE to SGND	-0.3 to 40	
	Maximum LX RMS current	2.0	
P <sub>TOT</sub>	Power dissipation @ = 25 °C	2.3	W
	Maximum withstanding voltage range test condition: CDF-AEC-Q100-002- "human body model" acceptance criteria: "normal performance"	± 2000	V

1. Stresses beyond those listed under "absolute maximum ratings" may cause permanent damage to the device. Exposure to absolute maximum rated conditions for extended periods may affect device reliability.

#### 3.2 Thermal data

**Table 4. Thermal data**

Symbol	Parameter	Value	Unit
R <sub>thJA</sub>	Thermal resistance junction to ambient	42	°C/W
T <sub>STG</sub>	Storage temperature range	-50 to 150	°C
T <sub>J</sub>	Junction operating temperature range	-40 to 125	°C
T <sub>A</sub>	Operating ambient temperature range	-40 to 85	°C

### 3.3 Recommended operating conditions

Table 5. Recommended operating conditions

Symbol	Parameter		Values			Unit
			Min	Typ	Max	
<b>Supply section</b>						
$V_{IN}$	Input voltage range		4.7	-	28	V
<b>Boost section</b>						
$V_{BST}$	Output voltage range			-	36	V
$f_{SW}$	Adjustable switching frequency	F <sub>SW</sub> connected to R <sub>F<sub>SW</sub></sub>	200	-	1000	kHz
	F <sub>SW</sub> sync input duty-cycle			-	40	%
$I_{rowx}$	ROWs output maximum current			-	32	mA

## 4 Electrical characteristics

$V_{IN} = 12\text{ V}$ ;  $T_A = 0\text{ }^{\circ}\text{C}$  to  $85\text{ }^{\circ}\text{C}$  and MODE connected to AVCC unless specified <sup>(1)</sup>.

**Table 6. Electrical characteristics**

Symbol	Parameter	Test condition	Values			Unit
			Min	Typ	Max	
<b>Supply section</b>						
$V_{LDO5}, V_{AVCC}$	LDO output and IC supply voltage	EN High, $I_{LDO5} = 0\text{ mA}$	4.6	5	5.5	V
$I_{IN,Q}$	Operating quiescent current	$R_{RILIM} = 51\text{ k}\Omega$ , $R_{BILIM} = 220\text{ k}\Omega$ , $R_{SLOPE} = 680\text{ k}\Omega$ DIM tied to SGND.		1		mA
$I_{IN,SHDN}$	Operating current in shutdown	EN low		20	30	$\mu\text{A}$
$V_{UVLO,ON}$	LDO5 under voltage lockout upper threshold			4.6	4.75	V
$V_{UVLO,OFF}$	LDO5 under voltage lockout lower threshold		3.8	4.0		
<b>LDO linear regulator</b>						
	Line regulation	$6\text{ V} = V_{IN} = 28\text{ V}$ , $I_{LDO5} = 30\text{ mA}$			25	mV
	LDO dropout voltage	$V_{IN} = 4.3\text{ V}$ , $I_{LDO5} = 10\text{ mA}$		80	120	
	LDO maximum output current limit	$V_{LDO5} > V_{UVLO,ON}$	25	40	60	mA
		$V_{LDO5} < V_{UVLO,OFF}$			30	

1.  $T_A = T_J$ . All parameters at operating temperature extremes are guaranteed by design and statistical analysis (not production tested)

Table 6. Electrical characteristics (continued)

Symbol	Parameter	Test condition	Values			Unit
			Min	Typ	Max	
<b>Boost section</b>						
$t_{on,min}$	Minimum switching on time				200	ns
	Default switching frequency	FSW connected to AVCC	570	660	750	kHz
	Minimum FSW Sync frequency			210		
	FSW sync Input low level threshold		240			mV
	FSW sync Input hysteresis			60		
	FSW sync Min ON time				270	ns
	SYNC output duty-cycle	FSW connected to AVCC (Internal oscillator selected)		34	40	%
	SYNC output high level	$I_{SYNC} = 10 \mu A$	$V_{AVCC} - 20$			mV
	SYNC output low level	$I_{SYNC} = -10 \mu A$			20	
<b>Power switch</b>						
$K_B$	LX current coefficient	$R_{BILIM} = 300 k\Omega$	5.7e5	6.7e5	7.7e5	V
	Internal MOSFET $R_{DSon}$			280	500	m $\Omega$
<b>OV protections</b>						
$V_{TH,OVP}$	Overvoltage protection reference (OVSEL) threshold		1.190	1.235	1.280	V
$V_{TH,FRD}$	Floating ROWs detection (OVSEL) threshold		1.100	1.145	1.190	V
$\Delta V_{OVP,FRD}$	Voltage gap between the OVP and FRD thresholds			90		mV

**Table 6. Electrical characteristics (continued)**

Symbol	Parameter	Test condition	Values			Unit
			Min	Typ	Max	
<b>Soft-start and power management</b>						
	EN, turn-on level threshold				1.6	V
	EN, turn-off level threshold		0.8			
	DIM, high level threshold				1.3	
	DIM, low level threshold		0.8			
	EN, pull-up current			2.5		μA
	SS, charge current		4	5	6	
	SS, end-of-startup threshold		2	2.4	2.8	V
	SS, reduced switching frequency Release threshold			0.8		
<b>Current generators section</b>						
T <sub>DIM-ON,min</sub>	Minimum dimming on-time	R <sub>RILIM</sub> = 51 kΩ		500		ns
K <sub>R</sub>	ROWs current coefficient accuracy	R <sub>RILIM</sub> = 51 kΩ		998	±21	V
ΔI <sub>ROWx</sub>	ROWs current mismatch <sup>(1)</sup>	R <sub>RILIM</sub> = 51 kΩ			±2	%
V <sub>IFB</sub>	Feedback regulation voltage	No LEDs mismatch		400		mV
V <sub>TH,FAULT</sub>	Shorted LED fault detection threshold			8.2		V
V <sub>FAULT,LOW</sub>	FAULT pin low-level voltage	I <sub>FAULT,SINK</sub> = 4 mA			350	mV
<b>Thermal shutdown</b>						
T <sub>SHDN</sub>	Thermal shutdown Turn-off temperature			150		°C

Note: The current mismatch is the maximum current difference among the ROWs of one device.

## 5 Typical operating characteristics

All the measures are done with a standard PM6600EVAL demonstration board and a standard WLED6021NB tamboured, with the components listed in the EVAL\_KIT document.

The measures are done with this working conditions, unless specified:

- $V_{in} = 12\text{ V}$
- $V_{out} = 6\text{ rows} \times 10\text{ WLEDs} = 34\text{ V (typ)}$
- $I_{out} = 20\text{ mA}$  each row
- $f_{sw} = 660\text{ kHz}$  (nominal switching frequency, with FSW. AVCC)
- $V_{row1}$  to  $V_{row6} = \{0.697, 0.75, 0.818, 0.696, 0.822, 0.363\}\text{ V}$

**Figure 3. Efficiency vs DIM duty cycle @  $f_{DIM} = 200\text{ Hz}$**

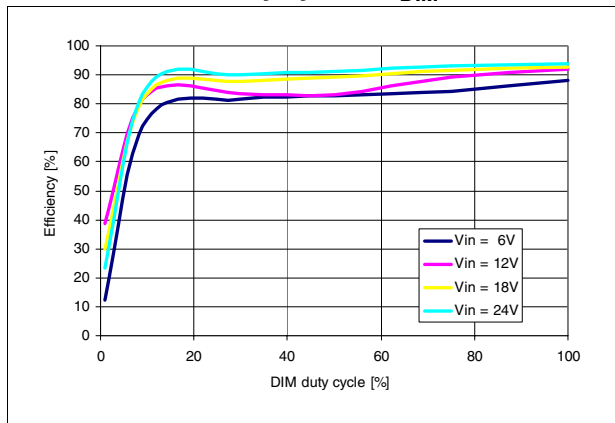

**Figure 4. Efficiency vs DIM duty cycle @  $f_{DIM} = 500\text{ Hz}$**

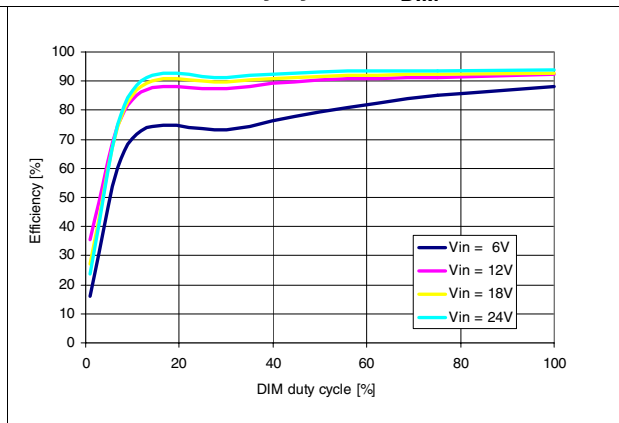

**Figure 5. Efficiency vs DIM duty cycle @  $f_{DIM} = 1\text{ kHz}$**

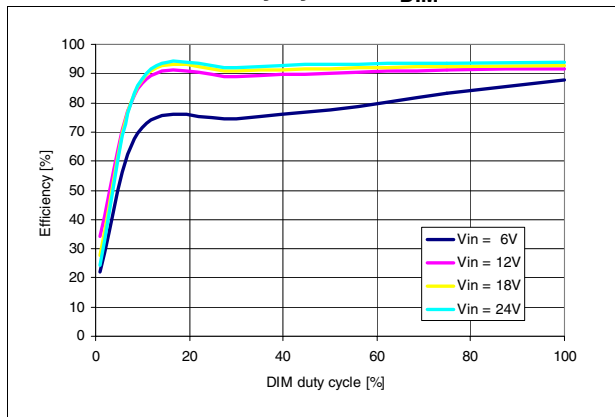

**Figure 6. Efficiency vs DIM duty cycle @  $f_{DIM} = 5\text{ kHz}$**

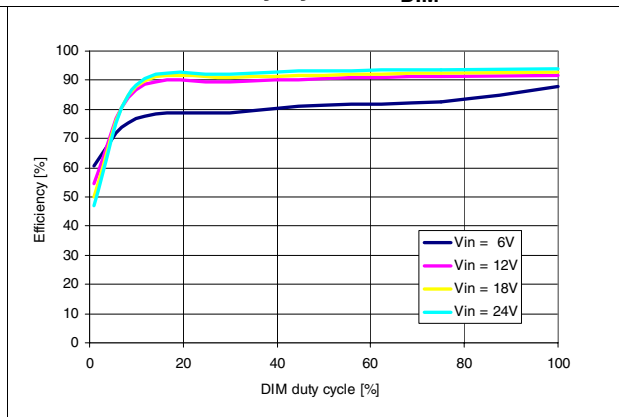

**Figure 7. Efficiency vs DIM duty cycle @  $f_{DIM} = 10\text{ kHz}$**

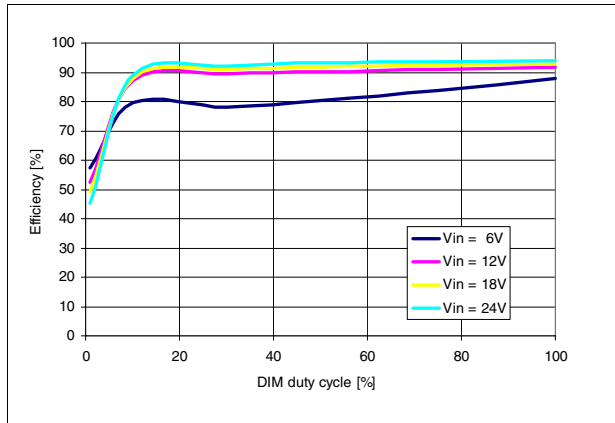

**Figure 8. Efficiency vs DIM duty cycle @  $f_{DIM} = 20\text{ kHz}$**

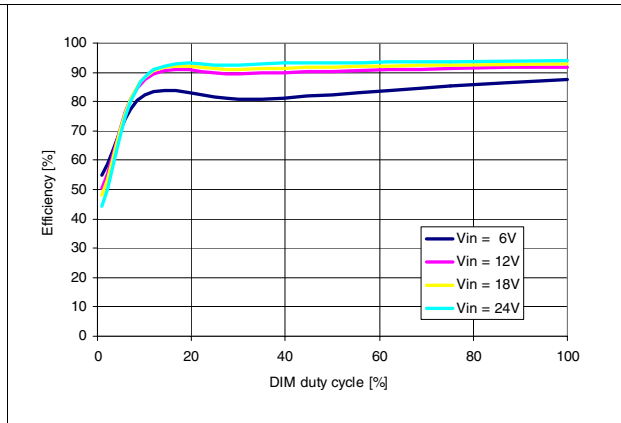

**Figure 9. Efficiency vs DIM duty cycle @  $V_{in} = 8\text{ V}$**

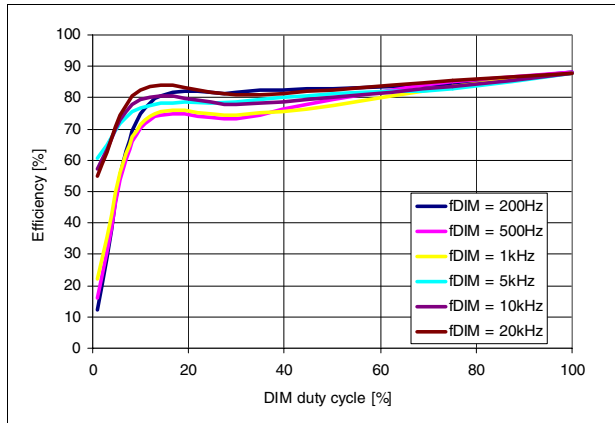

**Figure 10. Efficiency vs DIM duty cycle @  $V_{in} = 12\text{ V}$**

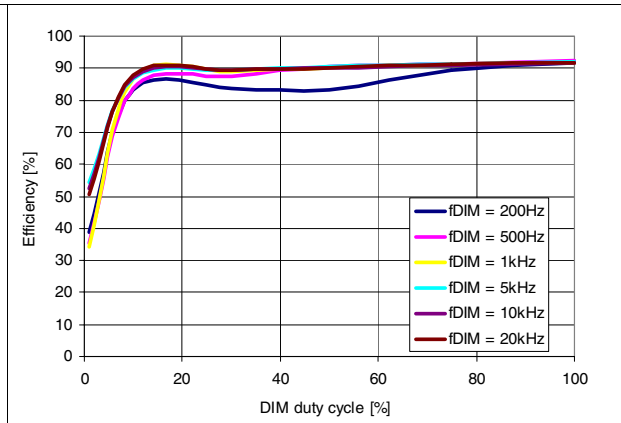

**Figure 11. Efficiency vs DIM duty cycle @  $V_{in} = 18\text{ V}$**

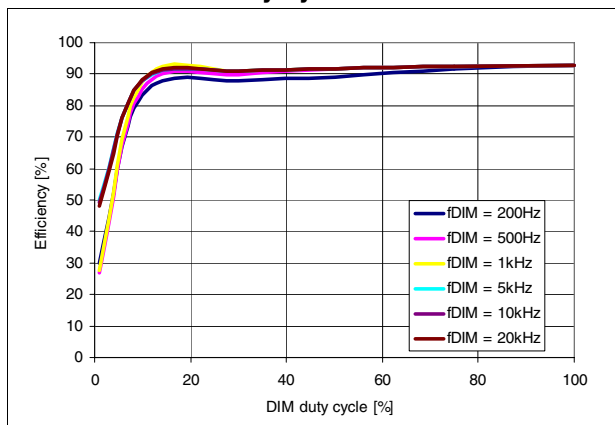

**Figure 12. Efficiency vs DIM duty cycle @  $V_{in} = 24\text{ V}$**

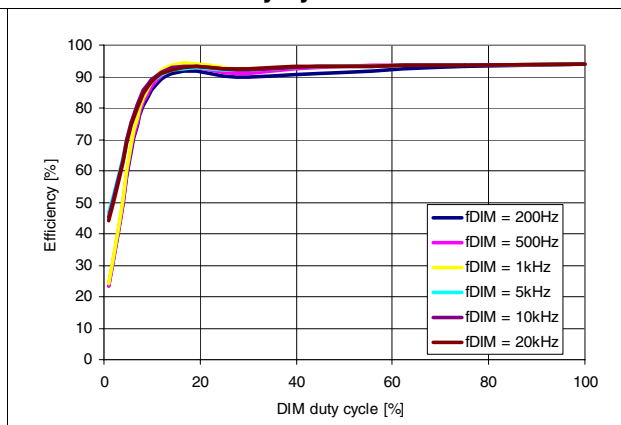

**Figure 13. Efficiency vs Vin @ DIM duty cycles = 10%**

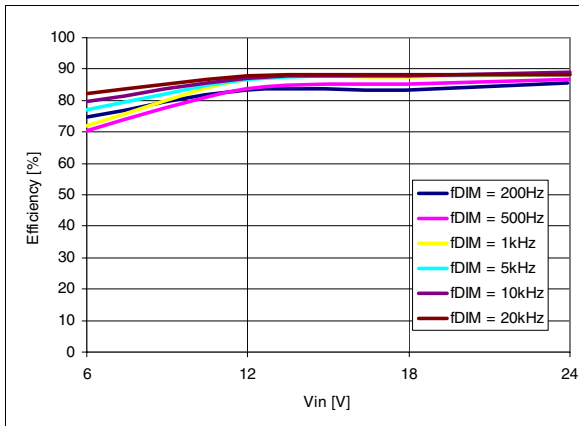

**Figure 14. Efficiency vs Vin @ DIM duty cycles = 50%**

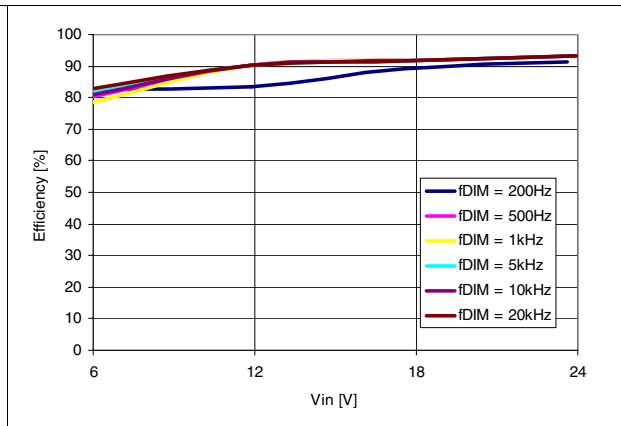

**Figure 15. Efficiency vs Vin @ DIM duty cycles = 75%**

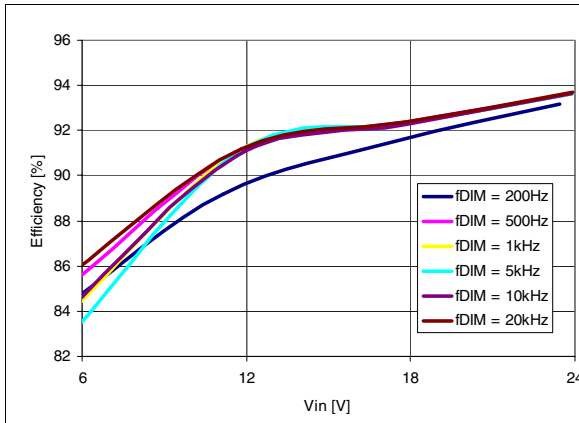

**Figure 16. Efficiency vs Vin @ DIM duty cycles = 100%**

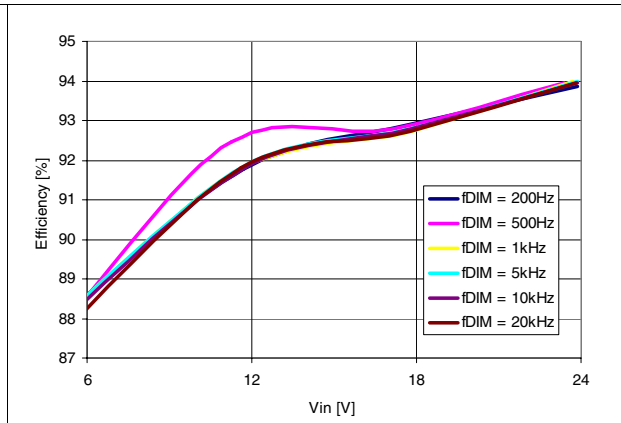

Figure 17. Working waveforms @  $f_{DIM} = 100 \text{ Hz}$ ,  $D = 1\%$

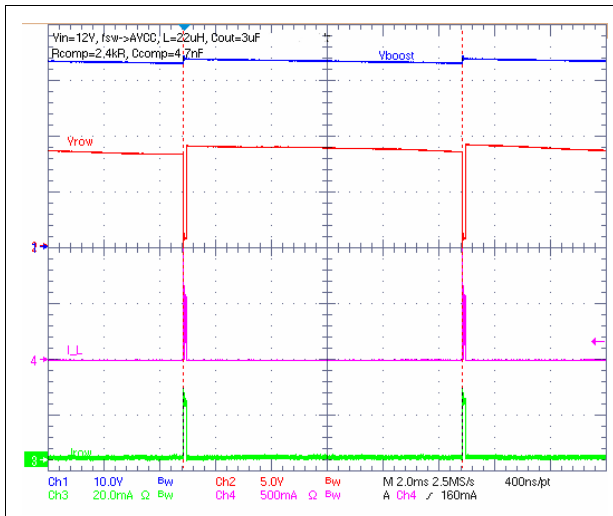

Figure 18. Working waveforms @  $f_{DIM} = 100 \text{ Hz}$ ,  $D = 10\%$

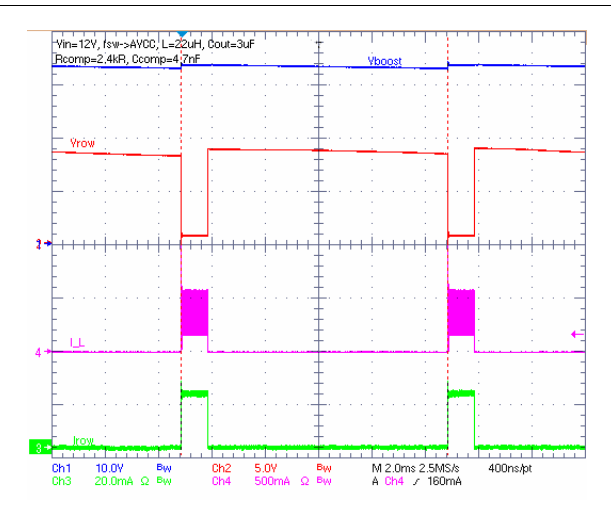

Figure 19. Working waveforms @  $f_{DIM} = 100 \text{ Hz}$ ,  $D = 50\%$

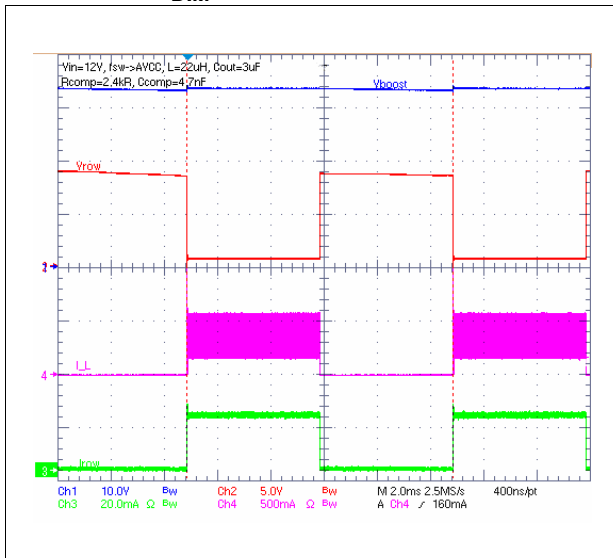

Figure 20. Working waveforms @  $f_{DIM} = 100 \text{ Hz}$ ,  $D = 80\%$

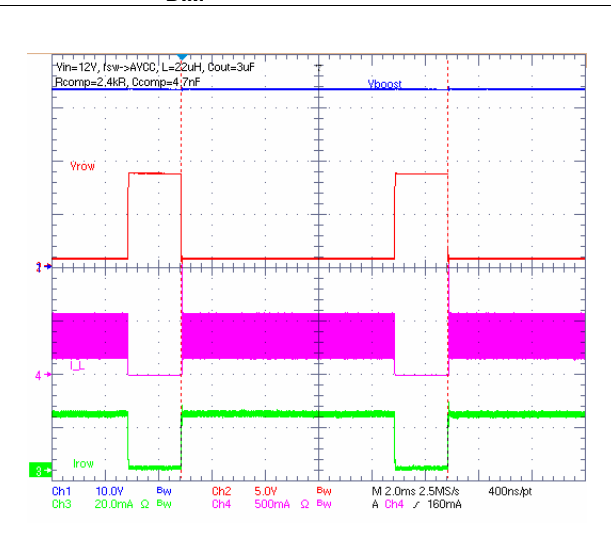

Figure 21. Working waveforms @  $f_{DIM} = 200 \text{ Hz}$ ,  $D = 1\%$

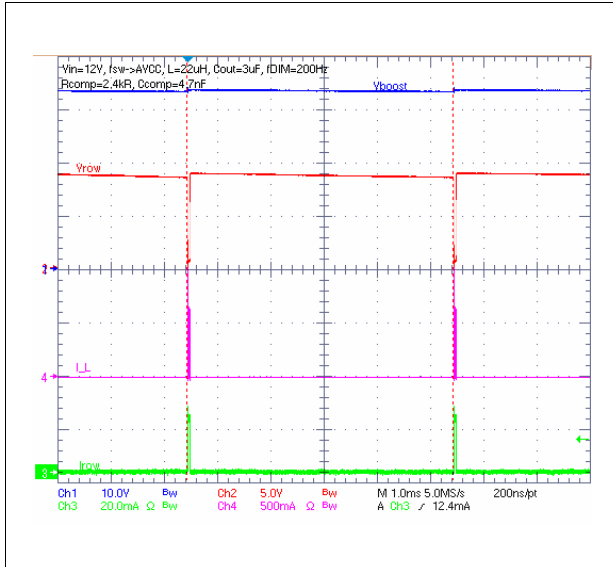

Figure 22. Working waveforms @  $f_{DIM} = 200 \text{ Hz}$ ,  $D = 20\%$

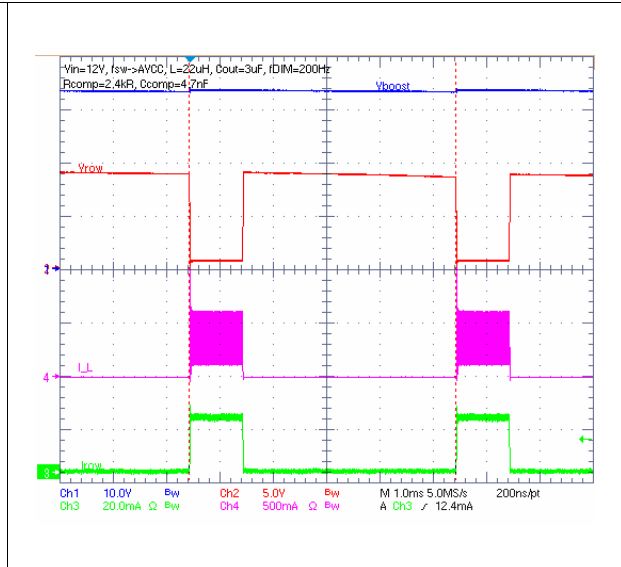

Figure 23. Working waveforms @  $f_{DIM} = 200 \text{ Hz}$ ,  $D = 50\%$

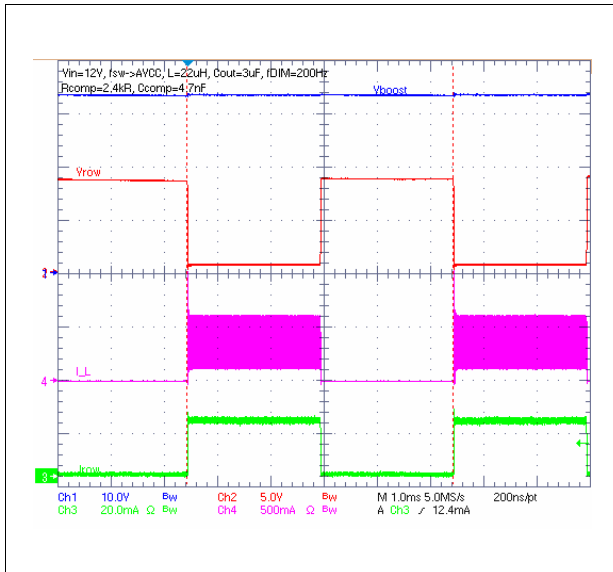

Figure 24. Working waveforms @  $f_{DIM} = 200 \text{ Hz}$ ,  $D = 80\%$

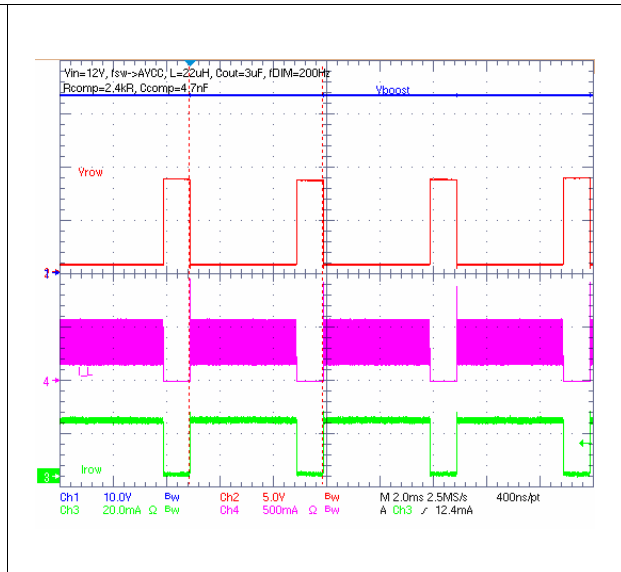

Figure 25. Working waveforms @  $f_{DIM} = 500 \text{ Hz}$ ,  $D = 1\%$

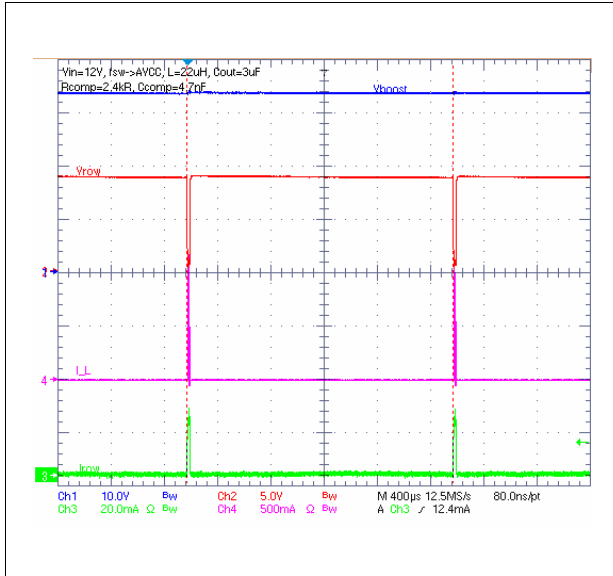

Figure 26. Working waveforms @  $f_{DIM} = 500 \text{ Hz}$ ,  $D = 50\%$

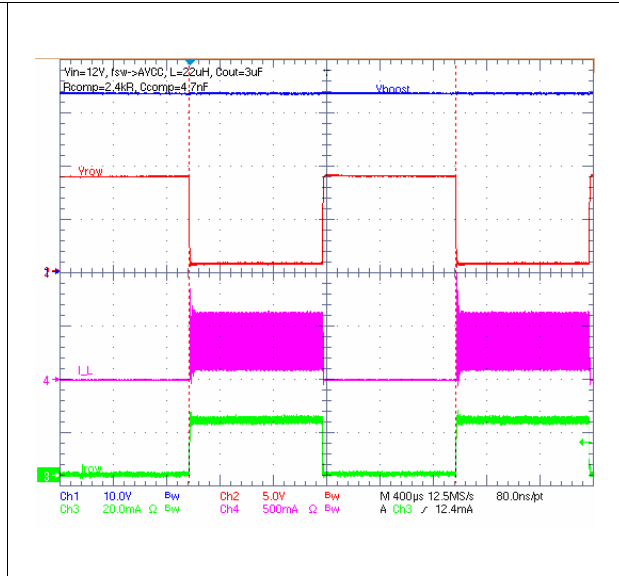

Figure 27. Working waveforms @  $f_{DIM} = 1 \text{ kHz}$ ,  $D = 1\%$

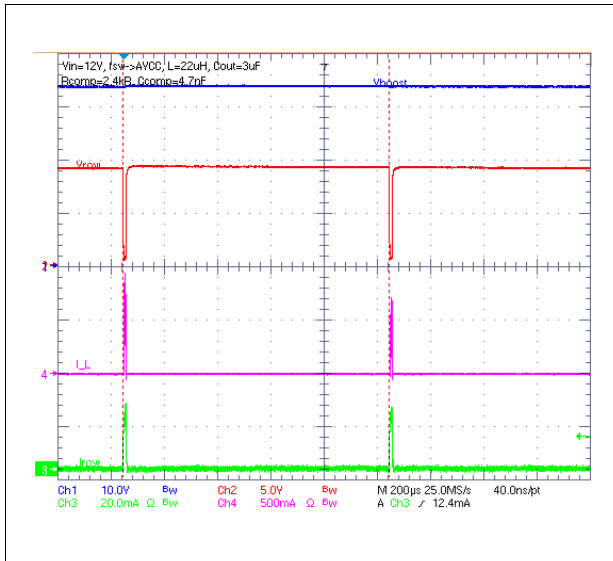

Figure 28. Working waveforms @  $f_{DIM} = 1 \text{ kHz}$ ,  $D = 50\%$

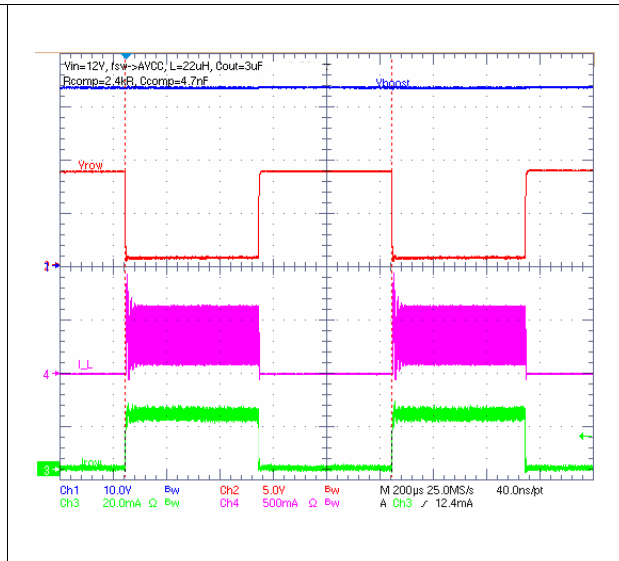

Figure 29. Working waveforms @  $f_{DIM} = 10\text{ kHz}$ ,  $D = 1\%$

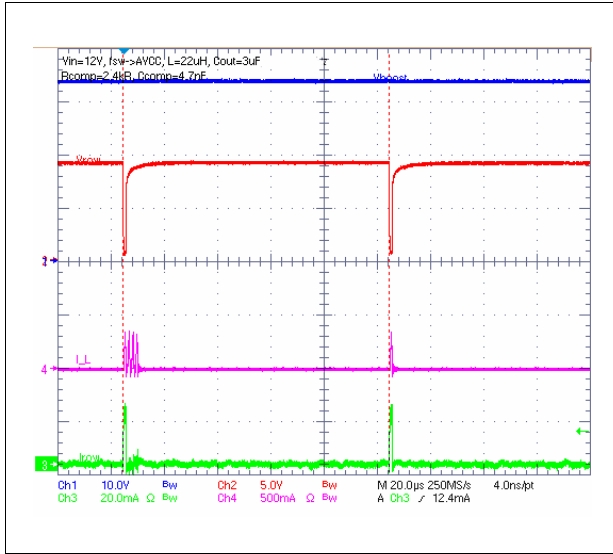

Figure 30. Working waveforms @  $f_{DIM} = 10\text{ kHz}$ ,  $D = 50\%$

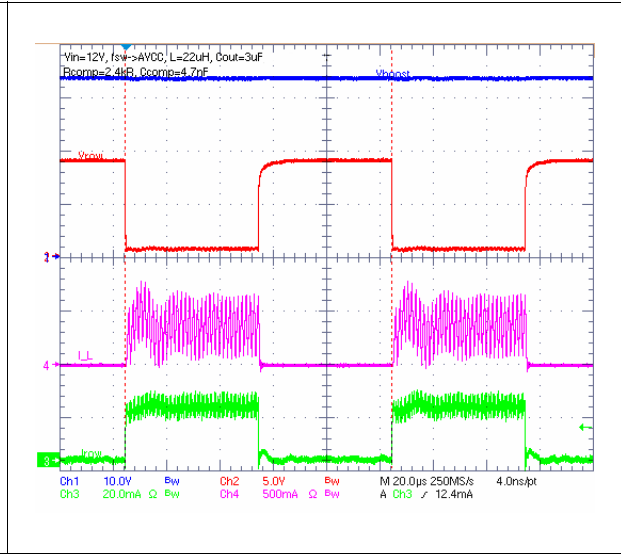

Figure 31. Working waveforms @  $f_{DIM} = 20\text{ kHz}$ ,  $D = 1\%$

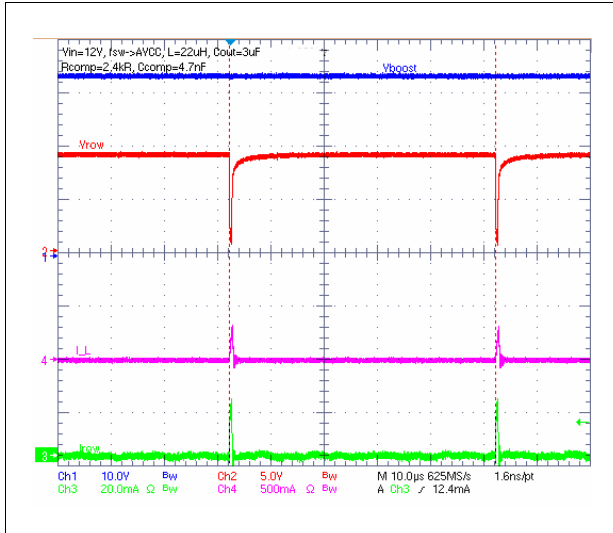
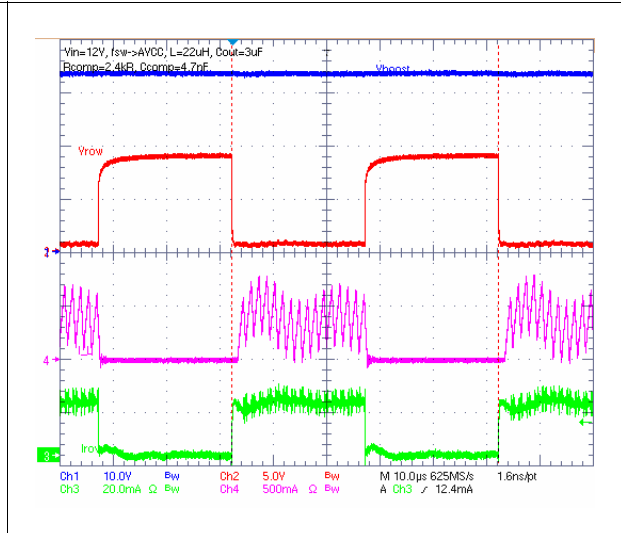
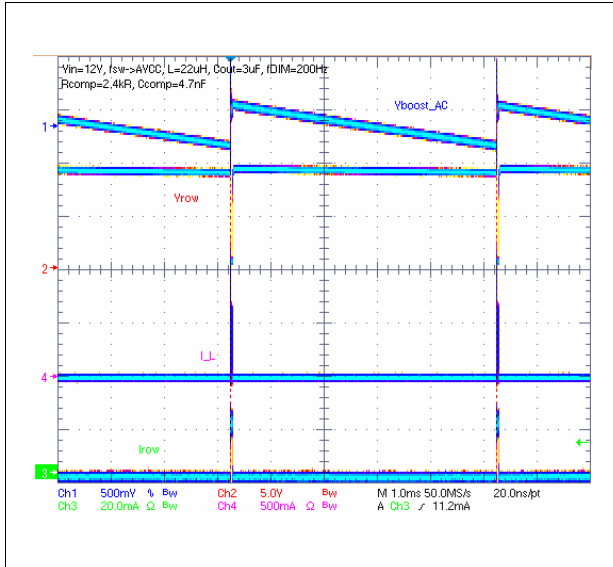

Figure 32. Working waveforms @  $f_{DIM} = 20\text{ kHz}$ ,  $D = 50\%$



**Figure 33. Output voltage ripple @  $f_{DIM} = 200\text{ Hz}$ ,  $D = 1\%$**



**Figure 34. Output voltage ripple @  $f_{DIM} = 200\text{ Hz}$ ,  $D = 20\%$**

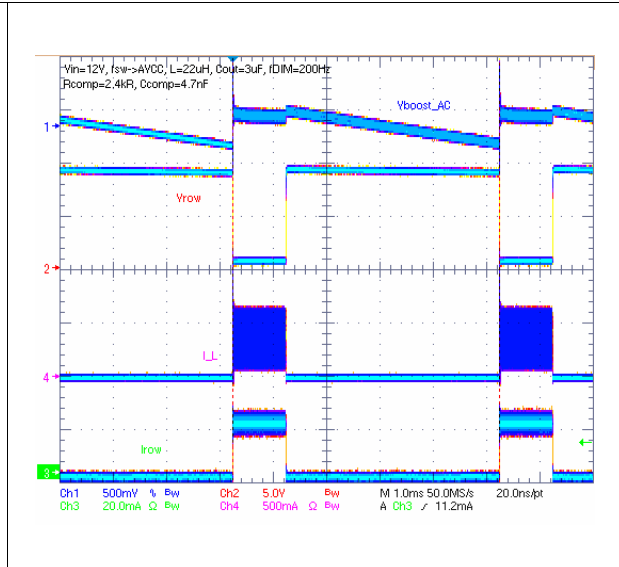

**Figure 35. Output voltage ripple @  $f_{DIM} = 200\text{ Hz}$ ,  $D = 50\%$**

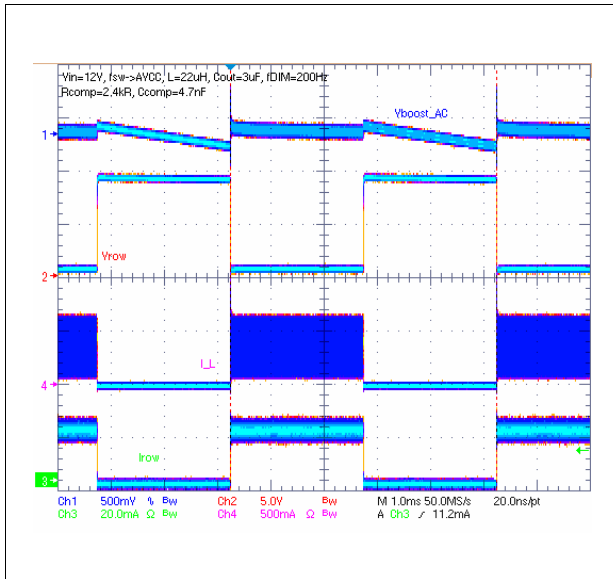

**Figure 36. Output voltage ripple @  $f_{DIM} = 200\text{ Hz}$ ,  $D = 80\%$**

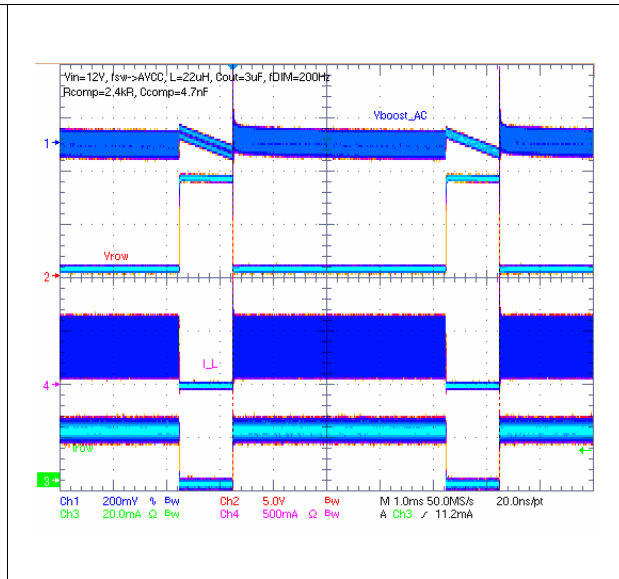

**Figure 37. Shorted LED protection @  $f_{DIM} = 200$  Hz all WLEDs connected**

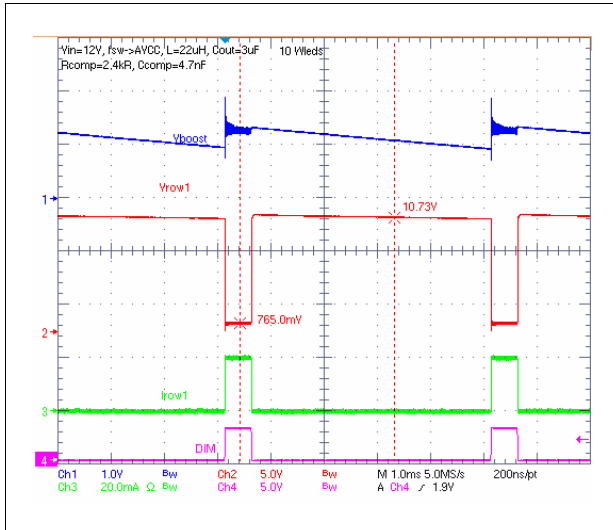

**Figure 38. Shorted LED protection @  $f_{DIM} = 200$  Hz 1 WLED shorted**

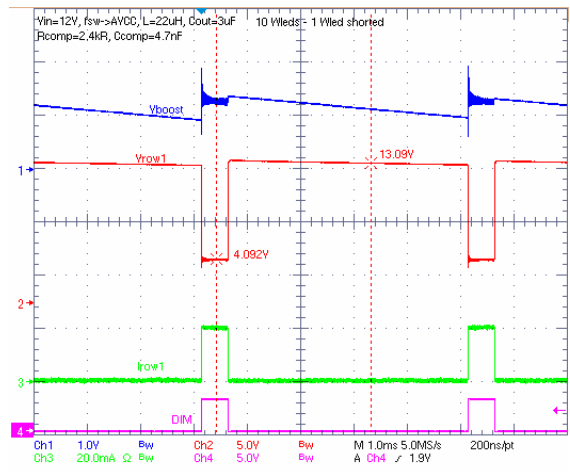

**Figure 39. Shorted LED protection @  $f_{DIM} = 200$  Hz 2 WLEDs shorted**

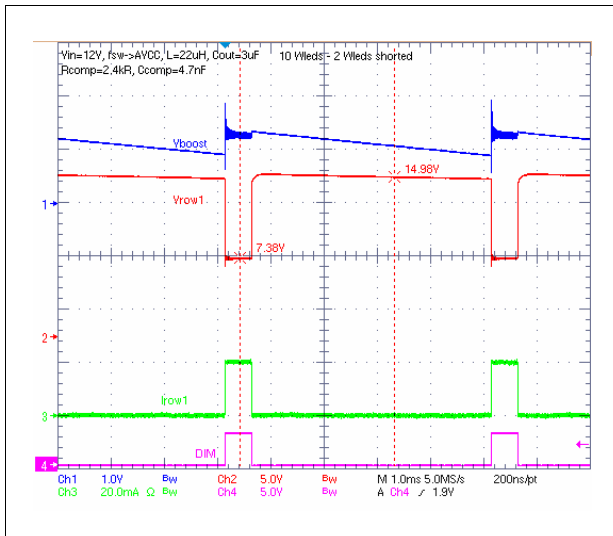

**Figure 40. Shorted LED protection @  $f_{DIM} = 200$  Hz 3 WLEDs shorted - ROW disabled**

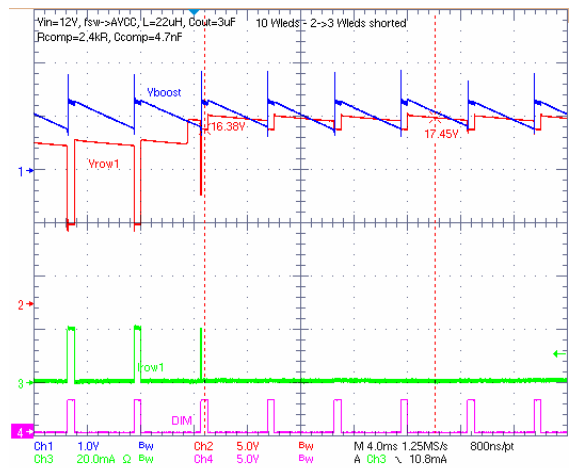
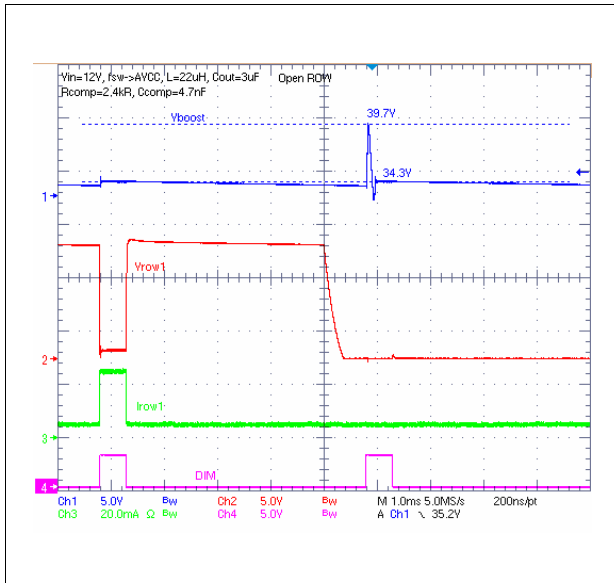
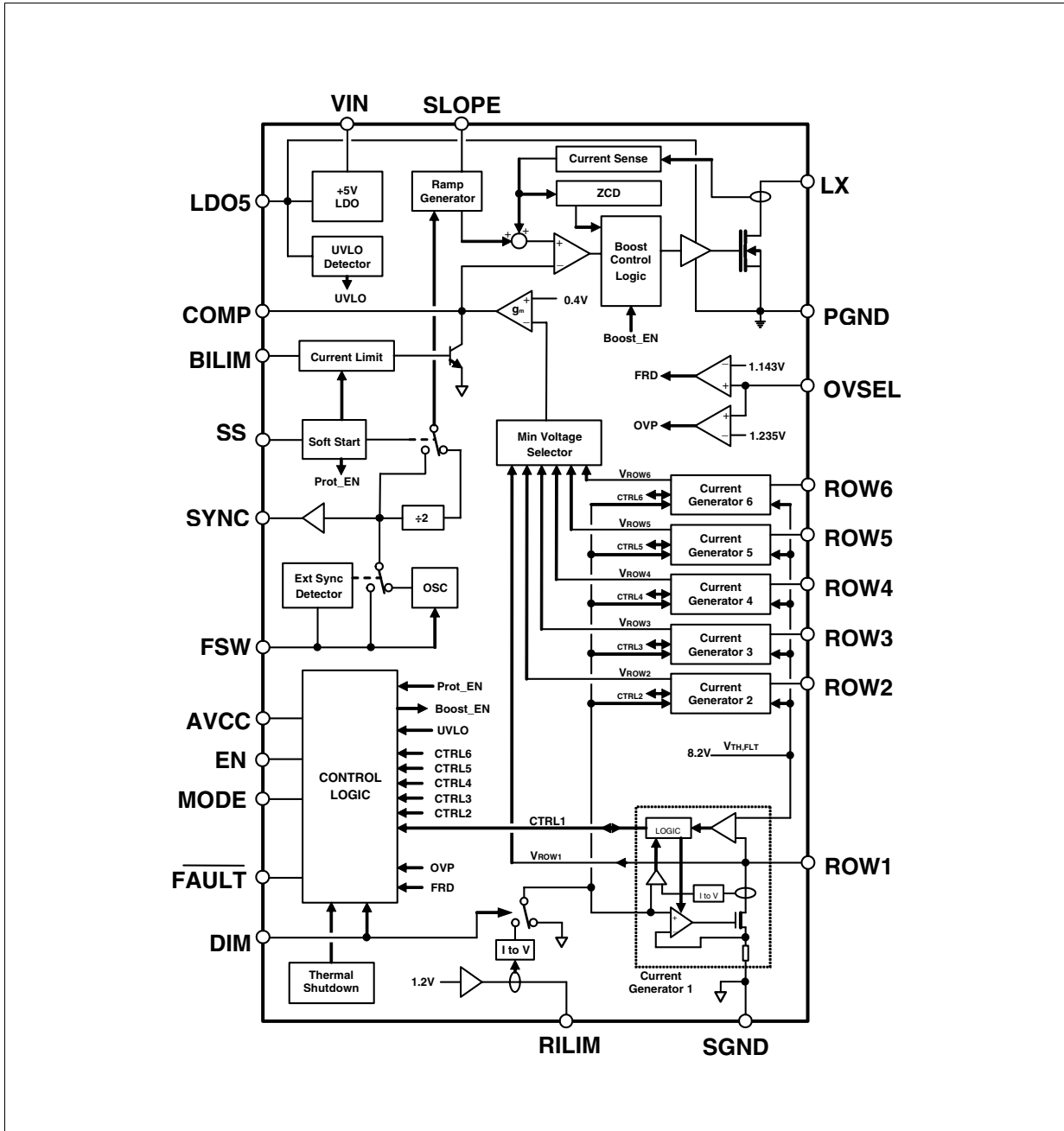

Figure 41. Open ROW detection @  
 $f_{DIM} = 200 \text{ Hz}$



# 6 Block diagram

Figure 42. Simplified block diagram



## 7 Operation description

### 7.1 Boost section

#### 7.1.1 Functional description

The PM6600 is a monolithic LEDs driver for the backlight of LCD panels and it consists of a boost converter and six PWM-dimmable current generators.

The input voltage range is from 4.7 V up to 28 V.

The boost section is based on a constant switching frequency, Peak Current-Mode architecture. The boost output voltage is controlled such that the lowest ROWs' voltage, referred to SGND, is equal to an internal reference voltage (400 mV typ.).

In addition, the PM6600 has an internal LDO that supplies the internal circuitry of the device and is capable to deliver up to 40 mA. The input of the LDO is the VIN pin. The LDO5 pin is the LDO output and the supply for the power-MOSFET driver at the same time. The AVCC pin is the supply for the analog circuitry and should be connected to the LDO output through a simple RC filter, in order to improve the noise rejection.

**Figure 43. AVCC filtering**

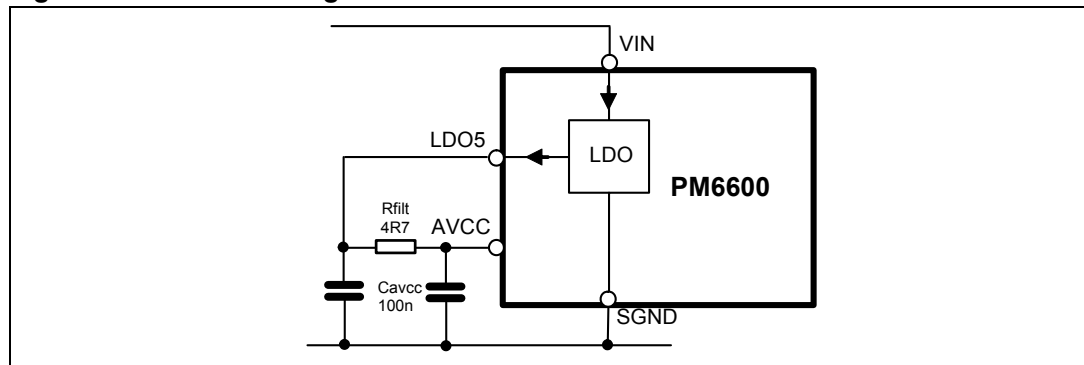

Two loops are involved in regulating the current sunk by the generators.

The main loop is related to the boost regulator and uses a constant frequency peak current-mode architecture (see [Figure 49](#)), while an internal current loop regulates the same current at each ROW according to the set value (RILIM pin).

A dedicated circuit automatically selects the lowest voltage drop among all the ROWs and provides this voltage the main loop that, in turn, regulates the output voltage. In fact, once the reference generator has been detected, the error amplifier compares its voltage drop to the internal reference voltage and varies the COMP output. The voltage at the COMP pin determines the inductor peak current at each switching cycle. The output voltage of the boost regulator is thus determined by the total forward voltage of the LEDs strings:

**Equation 1**

$$V_{OUT} = \max_{i=1}^{N_{ROWS}} \left( \sum_{j=1}^{m_{LEDS}} V_{F,j} \right) + 400mV$$

where the first term represents the highest total forward voltage drop over active ROWs and the second is the voltage drop across the leading generator (400 mV typ.).

The device continues to monitor the voltage drop across all the rows and automatically switches to the current generator having the lowest voltage drop.

## 7.2 Overvoltage protection

An adjustable over-voltage protection is available. It can be set feeding the OVSEL pin with a partition of the output voltage. The voltage of the central tap of the divider is thus compared to a fixed 1.235 V threshold. When the voltage on the OVSEL pin exceeds the OV threshold, the FAULT pin is tied low (see [Section 9 on page 39](#)) and the device is turned off; this condition is latched and the PM6600 is restarted by toggling the EN pin or by performing a power-on reset (the POR occurs when the LDO output falls below the lower UVLO threshold and subsequently crosses the upper UVLO threshold during the rising phase of the input voltage). Normally, the value of the high-side resistors of the divider is in the order of 100kΩ to reduce the output capacitor discharge when the boost converter is off (during the off phase of the dimming cycle).

The OVSEL divider should be a compensated one, with the capacitors C10 (typically in the 100 pF-330 pF range) that improves noise rejection at the OVSEL pin (see [Figure 44](#)) and C13 (typically 22 pF) that avoids OVP fault detection when a row is open.

The following formulas permit to properly select the OVP threshold, according to the VOUT value and considering the worst case (maximum VF\_WLED):

### Equation 2

$$V_{OUTmax} + 3V < V_{OVP} < V_{OUT} + V_{OUTmax} + 4.5V$$

### Equation 3

$$V_{OUTmax} = n_{WLED\_series} \cdot V_{F\_WLEDmax} + 0.4V$$

$V_{OUTmax}$  is the maximum output voltage considering the LED spread.

$V_{OVP}$  is the over-voltage protection threshold

The formula to choose the proper values for the resistors of the OVP divider is:

### Equation 4

$$R_1 = R_2 \left( \frac{V_{OVP}}{1.235 - 1} \right)$$

### Equation 5

$$C_{13} = 1.5 \cdot C_{10} \cdot \frac{R_2}{R_1}$$

Figure 44. OVP threshold setting

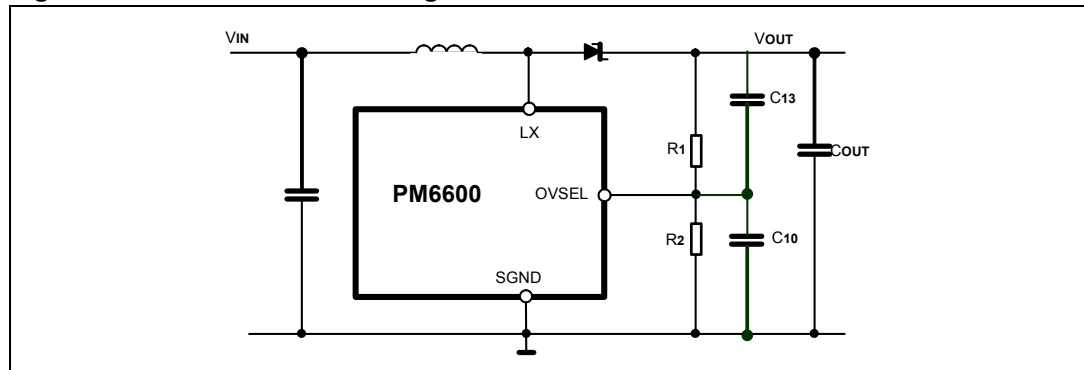

### 7.3 Switching frequency selection and synchronization

The switching frequency of the boost converter can be set in the 200 kHz-1 MHz range by connecting the FSW pin to ground through a resistor. Calculation of the setting resistor is made using equation 3 and should not exceed the 80 kΩ-400 kΩ range.

Equation 6

$$R_{FSW} = \frac{f_{sw}}{2.5}$$

In addition, when the FSW pin is tied to AVCC, the PM6600 uses a default 660 kHz fixed switching frequency, allowing to save a resistor in minimum components-count applications.

Figure 45. Multiple device synchronization

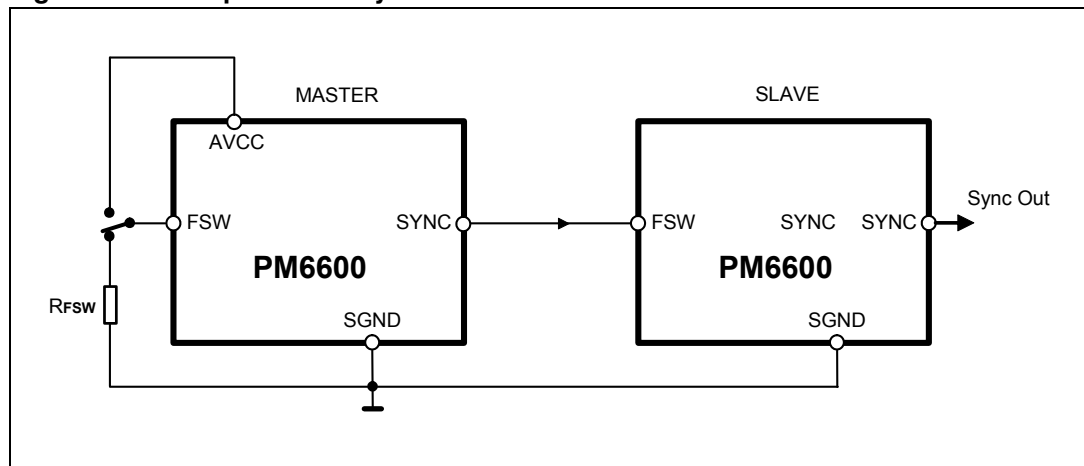

The FSW pin can also be used as a synchronization input, allowing the PM6600 to operate both as master or slave device. If a clock signal with a 210 kHz minimum frequency is applied to this pin, the device locks synchronized (300 mV threshold). An Internal time-out allows synchronization as long as the external clock frequency is greater than 210 kHz.

Keeping the FSW pin voltage lower than 300 mV for more than 1/210 kHz ≈ 5 μs results in the device turn off. Normal operation is resumed as soon as FSW rises above the mentioned threshold and the soft-start sequence is repeated.

The SYNC pin is a synchronization output and provides a 34% (typ.) duty-cycle clock when the PM6600 is used as master or a replica of the FSW pin when used as slave. It is used to connect multiple devices in a daisy-chain configuration or to synchronize other switching converters running in the system with the PM6600 (master operation).

When an external synchronization clock is applied to the FSW pin, the internal oscillator is over-driven: each switching cycle begins at the rising edge of clock, while the slope compensation ramp starts at the falling edge of the same signal. Thus, the external synchronization clock is required to have a 40% maximum duty-cycle when the boost converter is working in continuous-conduction mode (CCM). The minimum pulse width which allows the synchronizing pulses to be detected is 270 ns.

**Figure 46. External sync waveforms**

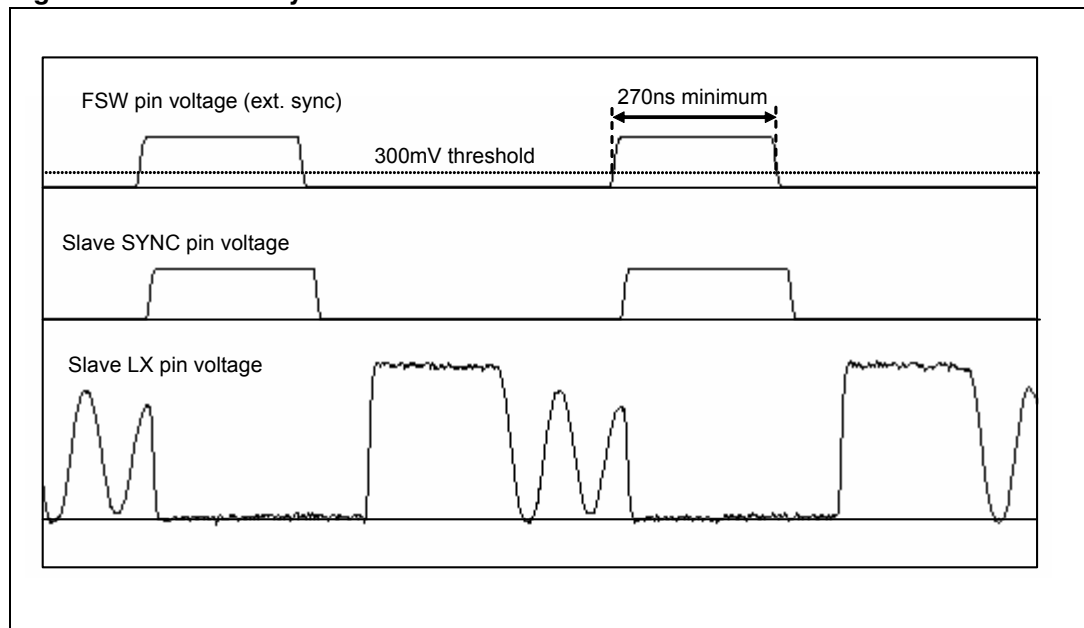

## 7.4 System stability

The boost section of the PM6600 is a fixed frequency, peak current-mode converter. During normal operation, a minimum voltage selection circuit compares all the voltage drops across the active current generators and provides the minimum one to the error amplifier. The output voltage of the error amplifier determines the inductor peak current in order to keep its inverting input equal to the reference voltage (400 mV typ). The compensation network consists of a simple RC series ( $R_{COMP}$  -  $C_{COMP}$ ) between the COMP pin and ground.

The calculation of  $R_{COMP}$  and  $C_{COMP}$  is fundamental to achieve optimal loop stability and dynamic performance of the boost converter and is strictly related to the operating conditions.

### 7.4.1 Loop compensation

The compensation network can be quickly calculated using equations 4 through 9. Once both  $R_{COMP}$  and  $C_{COMP}$  have been determined, a fine-tuning phase may be required in order to get the optimal dynamic performance from the application.

The first parameter to be fixed is the switching frequency. Normally, a high switching frequency allows reducing the size of the inductor but increases the switching losses and negatively affects the dynamic response of the converter. For most of applications, the fixed value (660 kHz) represents a good trade-off between power dissipation and dynamic response, allowing to save an external resistor at the same time. In low-profile applications, the inductor value is often kept low to reduce the number of turns; an inductor value in the 4.7  $\mu$ H-15  $\mu$ H range is a good starting choice.

Even if the loop bandwidth of the boost converter should be chosen as large as possible, it should be set to 20% of the switching frequency, taking care not to exceed the CCM-mode right half-plane zero (RHPZ).

#### Equation 7

$$f_U \leq 0.2 \cdot f_{SW}$$

#### Equation 8

$$f_U \leq 0.2 \cdot \frac{M^2 R}{2\pi \cdot L} = 0.2 \cdot \frac{\left(\frac{V_{IN,min}}{V_{OUT}}\right)^2 \left(\frac{V_{OUT}}{I_{OUT}}\right)}{2\pi \cdot L}$$

Where  $V_{IN,min}$  is the minimum input voltage,  $I_{OUT}$  is the overall output current,

$$M = \frac{V_{IN,min}}{V_{OUT}} \quad R = \frac{V_{OUT}}{I_{OUT}}$$

Note that, the lower the inductor value (or the lower the switching frequency) the higher the bandwidth can be achieved. The output capacitor is directly involved in the loop of the boost converter and must be large enough to avoid excessive output voltage drop in case of a sudden line transition from the maximum to the minimum input voltages ( $\Delta V_{OUT}$  should not exceed 50-100 mV):

**Equation 9**

$$\Delta V_{OUT} = \frac{I_{OUT}}{2\pi \cdot f_U \cdot C} \left( 1 - \frac{V_{IN\_MIN}}{V_{IN\_MAX}} \right)$$

Once the output capacitor has been chosen, the  $R_{COMP}$  can be calculated as:

**Equation 10**

$$R_{COMP} = \frac{2\pi \cdot f_U \cdot C}{G_M \cdot g_{EA} \cdot M}$$

Where  $G_M = 2.7 \text{ S}$  and  $g_{EA} = 375 \mu\text{S}$ .

The  $C_{COMP}$  capacitor is determined to place the frequency of the compensation zero 5 times lower than the loop bandwidth:

**Equation 11**

$$C_{COMP} = \frac{1}{2\pi \cdot f_Z \cdot R_{COMP}}$$

Where  $f_Z = f_U / 5$ .

The close loop gain function ( $G_{LOOP}$ ) is thus given by equation 10:

**Equation 12**

$$G_{LOOP} = G_M \cdot g_{EA} \cdot \left( R_{COMP} + \frac{1}{sC_{COMP}} \right) \cdot RM \frac{1-s \frac{L}{M^2R}}{1+sRC}$$

A simple technique to optimize different applications is to replace  $R_{COMP}$  with a  $20 \text{ k}\Omega$  trimmer and adjust its value to properly damp the output transient response. Insufficient damping will result in excessive ringing at the output and poor phase margin. Figures 5a and 5b give an example of compensation adjustment for a typical application.

**Figure 47. Poor phase margin (a) and properly damped (b) load transient responses**

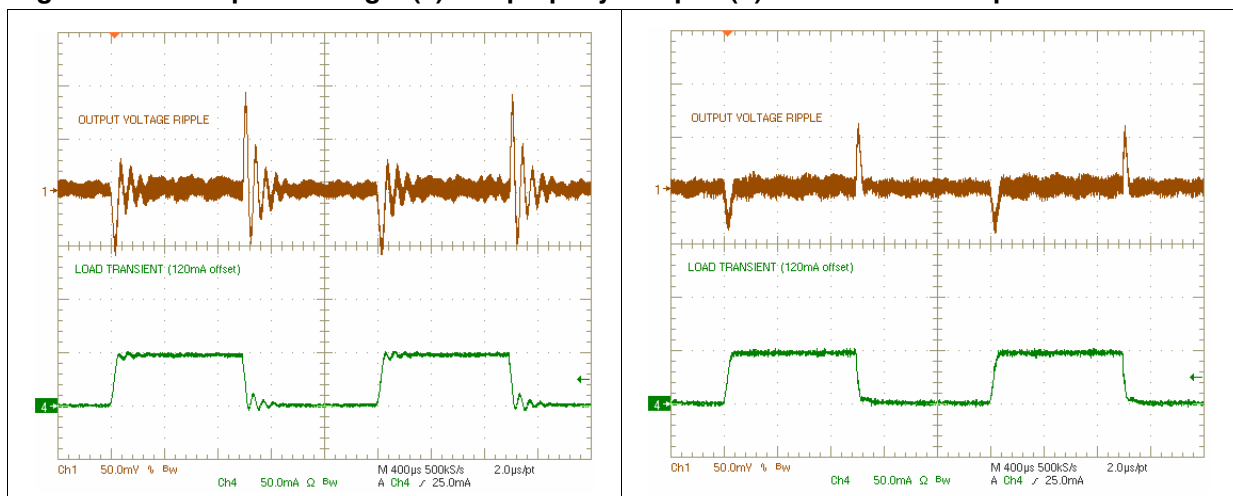
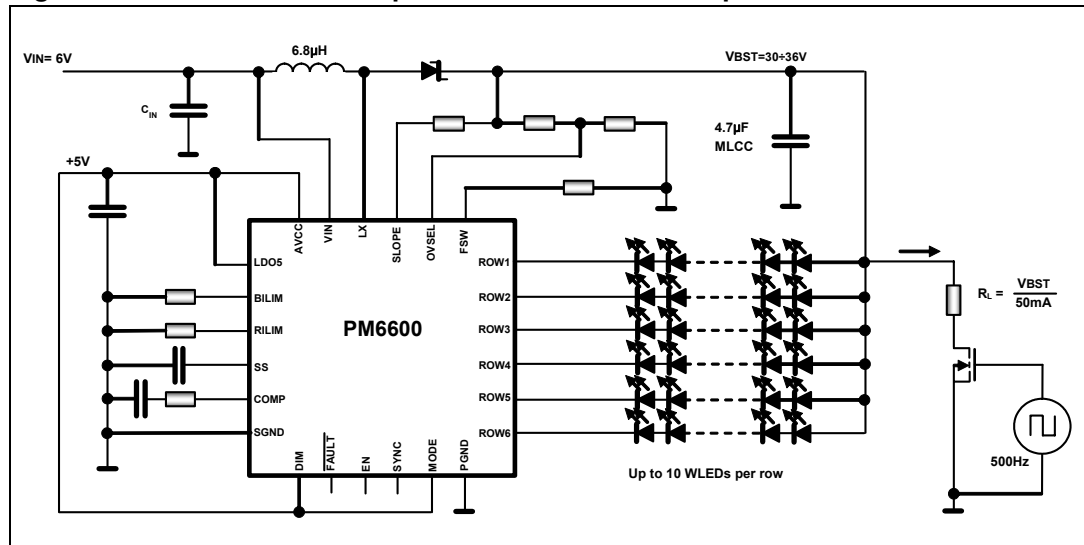

Figure 48. Load transient response measurement set-up



### 7.4.2 Slope compensation

The constant frequency, peak current-mode topology has the advantage of very easy loop compensation with output ceramic capacitors (reduced cost and size of the application) and fast transient response. In addition, the intrinsic peak-current measurement simplifies the current limit protection, avoiding undesired saturation of the inductor.

On the other side, this topology has a drawback: there is inherent open loop instability when operating with a duty-ratio greater than 0.5. This phenomenon is known as “sub-harmonic instability” and can be avoided by adding an external ramp to the one coming from the sensed current. This compensating technique, based on the additional ramp, is called “Slope Compensation”. In figure 11, where the switching duty-cycle is higher than 0.5, the small perturbation  $\Delta I_L$  dies away in subsequent cycles thanks to the slope compensation and the system reverts to a stable situation.

Figure 49. Main loop and current loop diagram

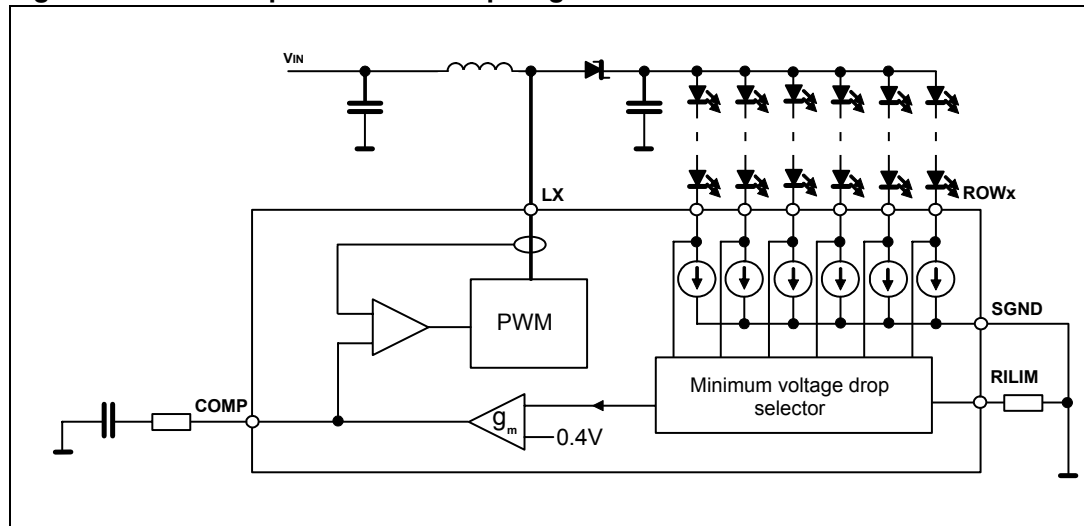

The SLOPE pin allows to properly set the amount of slope compensation connecting a simple resistor  $R_{SLOPE}$  between the SLOPE pin and the output. The compensation ramp starts at 35% (typ.) of each switching period and its slope is given by the following equation:

**Equation 13**

$$S_E = K_{SLOPE} \left( \frac{V_{OUT} - V_{IN} - V_{BE}}{R_{SLOPE}} \right)$$

Where  $K_{SLOPE}$ ,  $V_{BE} = 2 \text{ V}$  (typ.) and  $S_E$  is the slope ramp in [A/s].

To avoid sub-harmonic instability, the compensating slope should be at least half the slope of the inductor current during the off-phase for a duty-cycle greater than 50% (i.e. at the lowest input voltage). The value of  $R_{SLOPE}$  can be calculated according to equation 9.

**Equation 14**

$$R_{SLOPE} \leq \frac{2 \cdot K_{SLOPE} \cdot L \cdot (V_{OUT} - V_{IN} - V_{BE})}{(V_{OUT} - V_{IN})}$$

**Figure 50. Effect of slope compensation on small inductor current perturbation (D > 0.5)**

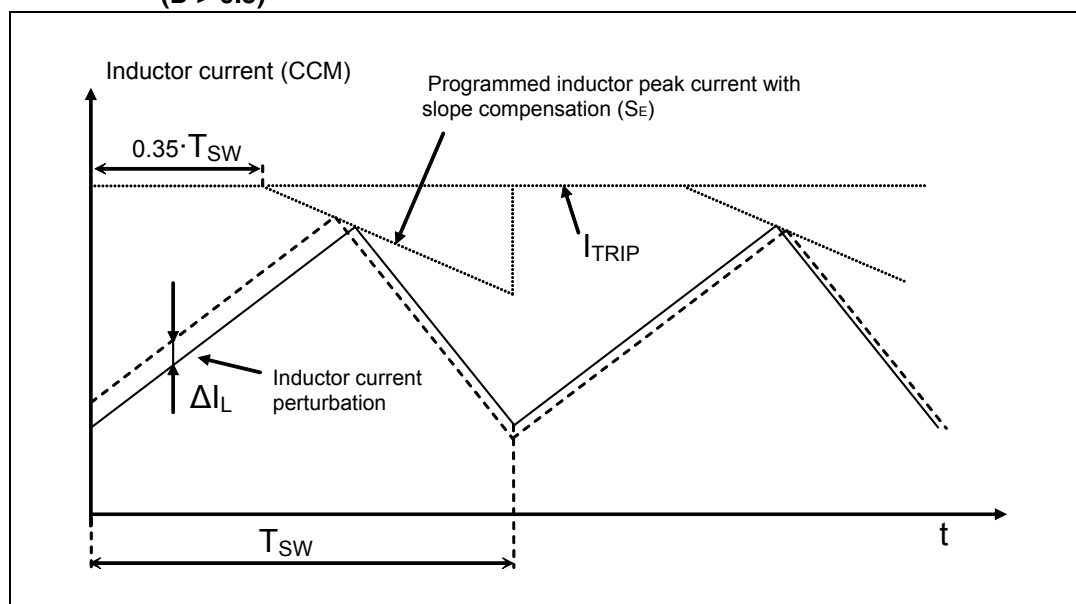

## 7.5 Soft-start

The soft-start function is required to perform a correct start-up of the system, controlling the inrush current required to charge the output capacitor and to avoid output voltage overshoot. The soft-start duration is set connecting an external capacitor between the SS pin and ground. This capacitor is charged with a 5 μA constant current, forcing the voltage on the SS pin to ramp up. When this voltage increases from zero to nearly 1.2 V, the current limit of the power-MOSFET is proportionally released to its final value. In addition, during the initial part of the Soft-Start, the switching frequency of the boost converter is reduced to half of the

nominal value to permit to use inductors with lower saturation current value; the nominal switching frequency is restored after the SS pin voltage has crossed 0.8 V. In this mode, the current runaway is avoided.

**Figure 51. Soft-start sequence waveforms in case of floating ROWs**

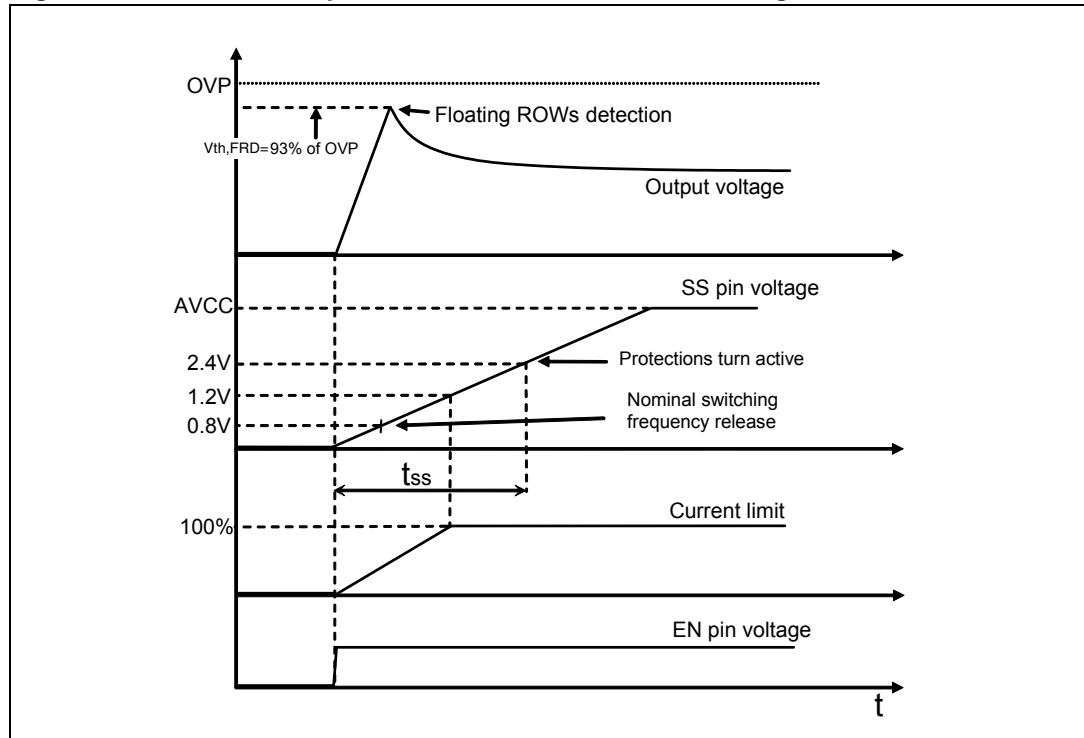

During the soft-start phase it is also performed the floating ROWs detection. In presence of one or more floating ROWs, the error amplifier is unbalanced and the output voltage increases; when it reaches the floating ROW Detection (FRD) threshold (93% of the OVP threshold), the floating ROWs are managed according to [Table 8](#) (see [Section 9 on page 39](#)). After the SS voltage reaches a 2.4 V threshold, the start-up finishes and all the protections turn active. The soft-start duration can be calculated with the following formula:

**Equation 15**

$$t_{SS} \cong 2.5 \frac{C_{SS}}{I_{SS}}$$

Where  $I_{SS} = 5 \mu A$ .

Please refer to the application note section for the  $C_{SS}$  value settings according to the different working conditions.

## 7.6 Boost current limit

The design of the external components, especially the inductor and the flywheel diode, must be optimized in terms of size relying on the programmable peak current limit. The PM6600 improves the reliability of the final application giving the way to limit the maximum current flowing into the critical components. A simple resistor connected between the BILIM pin and ground sets the desired value. The voltage at the BILIM pin is internally fixed to 1.2 V and the current limit is proportional to the current flowing through the setting resistor, according to the following equation:

**Equation 16**

$$I_{\text{BOOST,PEAK}} = \frac{K_B}{R_{\text{BILIM}}}$$

where  $K_B = 6.7 \cdot 10^5 \text{ V} \pm 15\%$  .

The maximum allowed current limit is 5 A, resulting in a minimum setting resistor  $R_{\text{BILIM}} > 120 \text{ k}\Omega$ . The maximum guaranteed RMS current in the power switch is 2 Arms. The current limitation works by clamping the COMP pin voltage proportionally to  $R_{\text{BILIM}}$ . Peak inductor current is limited to the above threshold decreased by the slope compensation contribution.

In a boost converter the r.m.s. current through the internal MOSFET depends on both the input and output voltages, according to equations 15a (DCM) and 15b (CCM).

**Equation 17 a**

$$I_{\text{MOS,rms}} = \frac{V_{\text{IN}} \cdot D}{F_{\text{SW}} \cdot L} \sqrt{\frac{D}{3}}$$

**Equation 17 b**

$$I_{\text{MOS,rms}} = I_{\text{OUT}} \sqrt{\left( \frac{D}{(1-D)^2} + \frac{1}{12} \left( \frac{V_{\text{OUT}}}{I_{\text{OUT}} \cdot f_{\text{SW}} \cdot L} \right)^2 (D(1-D))^3 \right)}$$

## 7.7 Enable function

The PM6600 is enabled by the EN pin. This pin is active high and, when forced to SGND, the device is turned off. This pin is connected to a permanently active 2  $\mu\text{A}$  current source; when sudden device turn-on at power-up is required, this pin must be left floating or connected to a delay capacitor. When turned off, the PM6600 quickly discharges the Soft-Start capacitor and turns off the power-MOSFET, the current generators and the LDO. The power consumption is thus reduced to 20  $\mu\text{A}$  only.

The proper startup sequence is DIM ' VIN ' EN, or VIN ' DIM ' EN. If the dimming signal is applied after the EN pin, the device will not perform the soft-start again, in fact it will start switching with the maximum current limit in order to recover the output voltage.

In applications where the dimming signal is used to turn on and off the device, the EN pin can be connected to the DIM pin as shown in [Figure 52](#).

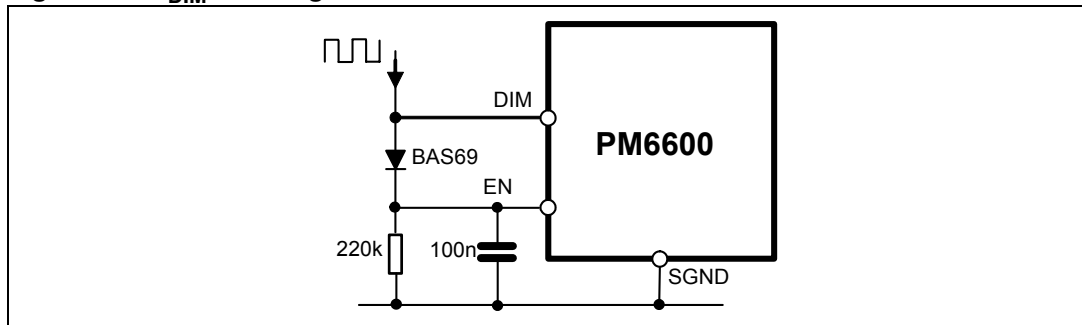
Figure 52.  $f_{DIM}$  enabling schematic

## 7.8 Thermal protection

In order to avoid damage due to high junction temperature, a thermal shutdown protection is implemented. When the junction temperature rises above 150 °C (typ.), the device turns off both the control logic and the boost converter and holds the FAULT pin low.

In order to turn on the device again, it is possible to perform a POR (power on reset) once the junction temperature has been reduced by 30 °C.

## 8 Backlight driver section

### 8.1 Current generators

The PM6600 is a LEDs driver with six channels (ROWS); each ROW is able to drive multiple LEDs in series (max. 40 V) and to sink up to 32 mA maximum current, allowing to manage different kinds of LEDs.

The LEDs current can be set by connecting an external resistor ( $R_{RILIM}$ ) between the RILIM pin and ground. The voltage across the RILIM pin is internally set to 1.2 V and the ROWs current is proportional to the RILIM current according to the following equation:

#### Equation 18

$$I_{ROWx} = \frac{K_R}{R_{RILIM}}$$

Where  $K_R = 998 \pm 21 \text{ V}$  ( $\pm 2.1\%$ ).

The current accuracy between the ROWs of more than one device is, consequently:

#### Equation 19

$$\Delta I_{ROW,MAX} = \frac{I_{ROW\_KR=1019} - I_{ROW\_KR=998}}{I_{ROW\_KR=998}} \leq + 2.1\%$$

$$\Delta I_{ROW,MIN} = \frac{I_{ROW\_KR=977} - I_{ROW\_KR=998}}{I_{ROW\_KR=998}} \geq - 2.1\%$$

In the table below there are the maximum, typical and minimum  $I_{ROW}$  values versus the  $R_{RILIM}$ :

**Table 7.  $I_{ROW}$  values versus  $R_{RILIM}$**

$R_{RILIM}$	$I_{ROW}$ @ KR = 977	$I_{ROW}$ @ KR = 998	$I_{ROW}$ @ KR = 1019
47.0 k $\Omega$	20.79 mA	21.68 mA	21.68 mA
49.9 k $\Omega$	19.58 mA	20.00 mA	20.42 mA
51.0 k $\Omega$	19.16 mA	19.57 mA	19.98 mA

The maximum current mismatch between the ROWs of one device is  $\pm 2\%$  @  $I_{ROWx} = 20 \text{ mA}$ , according to the formula:

**Equation 20**

$$\Delta I_{\text{ROWx,max}} = \frac{I_{\text{ROW\_max}} - I_{\text{ROW\_mean}}}{I_{\text{ROW\_mean}}} \leq + 2\%$$

$$\Delta I_{\text{ROWx,min}} = \frac{I_{\text{ROW\_min}} - I_{\text{ROW\_mean}}}{I_{\text{ROW\_mean}}} \geq - 2\%$$

$$I_{\text{ROW\_mean}} = \frac{\sum_{i=1}^6 I_{\text{ROW}i}}{6}$$

Due to the spread of the LEDs' forward voltage, the total drop across the LED's strings will be different. The device will manage the unconnected ROWs according to the MODE pin setting (see [Table 8](#)).

**8.2 PWM dimming**

The brightness control of the LEDs is performed by a pulse-width modulation of the ROWs current. When a PWM signal is applied to the DIM pin, the current generators are turned on and off mirroring the DIM pin behavior. Actually, the minimum dimming duty-cycle depends on the dimming frequency. The real limit to the PWM dimming is the minimum on-time that can be managed for the current generators; this minimum on-time is approximately 500 ns.

Thus, the minimum dimming duty-cycle depends on the dimming frequency according to the following formula:

**Equation 21**

$$D_{\text{DIM,min}} = 500\text{ns} \cdot f_{\text{DIM}}$$

For example, at a dimming frequency of 20 kHz, 1% of dimming duty-cycle can be managed.

The device can manage the condition  $f_{\text{DIM}} = 0$  Hz. However, in order to avoid any flickering issue due to the human eye cutoff frequency, we recommend to use  $f_{\text{DIM}} > 100$  Hz (condition verified with discrete smd leds without any light guide).

The  $f_{\text{DIM}}$  maximum value has to be 1/10 of the selected  $F_{\text{sw}}$ .

During the off-phase of the PWM signal the boost converter is paused, the current generators are turned off and the output voltage is frozen across the output capacitor.

During the start-up sequence the dimming duty-cycle is forced to 100% to detect floating ROWs regardless of the applied dimming signal.

## 9 Fault management

The main loop keeps the ROW having the lowest voltage drop regulated to about 400 mV. This value slightly depends on the voltage across the remaining active ROWs. After the soft-start sequence, all protections turn active and the voltage across the active current generators is monitored to detect shorted LEDs.

### 9.1 FAULT pin

The FAULT pin is an open-collector output, active low, which gives information regarding faulty conditions eventually detected. This pin can be used either to drive a status LED (with a series resistor to not exceed 4 mA current) or to warn the host system. The FAULT pin status is strictly related to the MODE pin setting (see [Table 8](#) for details).

### 9.2 MODE pin

The MODE pin is a digital input and can be connected to AVCC or SGND in order to choose the desired fault detection and management. The PM6600 can manage a faulty condition in two different ways, according to the application needs. [Table 8](#) summarizes how the device detects and handles the internal protections related to the boost section (over-current, over-temperature and over-voltage) and to the current generators section (open and shorted LEDs).

**Table 8. Faults management summary**

FAULT	MODE to GND	MODE to VCC
Internal MOSFET over current	FAULT pin HIGH power-MOS turned OFF	FAULT pin HIGH power-MOS turned OFF
Output over voltage	FAULT pin LOW device turned OFF latched	FAULT pin LOW device turned OFF latched
Thermal shutdown	FAULT pin LOW device turned OFF latched	FAULT pin LOW device turned OFF latched
Shorted LEDs on a single row	FAULT pin LOW faulty ROW DISABLED VTH,FAULT = 8.2 V	FAULT pin LOW faulty ROW DISABLED VTH,FAULT = 8.2 V
Shorted LEDs on more rows	FAULT pin LOW device latched OFF VTH,FAULT = 8.2 V	FAULT pin LOW faulty ROWs DISABLED VTH,FAULT = 8.2 V
Open row	FAULT pin LOW faulty ROW DISABLED	FAULT pin HIGH faulty ROW DISABLED
More than one open rows	FAULT pin LOW device latched OFF	FAULT pin HIGH faulty ROWs DISABLED
Open rows plus shorted led (different rows)	FAULT pin LOW device latched OFF VTH,FAULT = 8.2 V	FAULT pin LOW faulty ROWs DISABLED VTH,FAULT = 8.2 V

### 9.3 Open LED fault

In case a ROW is not connected or a LED fails open, the device has two different behaviors according to the MODE pin status.

If the MODE pin is high (connected to AVCC), the open ROW is excluded from the control loop and the device continues to work properly with the remaining ROWs, without asserting the FAULT pin.

Connecting the MODE pin to SGND, the PM6600 behaves in a different manner: as soon as one open ROW is detected, the FAULT pin is tied low. In case a second open ROW is detected, the device is turned off. The internal logic latches this status: to restore the normal operation, the device must be restarted by toggling the EN pin or performing a power on reset (POR occurs when the voltage at the LDO5 pin falls below the lower UVLO threshold and subsequently rises above the upper one).

As a consequence, if less than six ROWs are used in the application, the MODE pin must be set high.

### 9.4 Shorted LED fault

When a LED is shorted, the voltage across the related current generator increases of an amount equal to the missing voltage drop of the faulty LED. Since the feedback voltage on each active generator is constantly compared with a fixed fault threshold  $V_{TH,FAULT} = 8.2 V$ , the device detects the faulty condition and acts according to the MODE pin status.

In case the MODE pin is connected to AVCC, the PM6600 disconnects the ROWs whose voltage is higher than the threshold and the FAULT pin is tied low. This option is also useful to avoid undesired triggering of the shorted-LED protection simply due to the high voltage drop spread across the LEDs.

If the MODE pin is low, when the voltage across one ROW is higher than  $V_{TH,FAULT}$  threshold, the FAULT pin is set low and that ROW is disabled. If the voltage of a second ROW becomes higher than  $V_{TH,FAULT}$  threshold, the device is turned off. The internal logic latches this status until the EN pin is toggled or a POR is performed.

### 9.5 Intermittent connection

For intermittent connection it is intended the condition where the flat cable connector from the leds backlight driver to the leds can have some issues on moving the panel of the notebook. This kind of issue is represented as an intermittent connection, that means the physical electrical connection between the ROWx pins of the PM6600 device and the White LEDs can be open for a while.

The device will detect an open row fault.

There is one possible solution to determine whether the fault is due to the intermittent connection or to a broken persistent electrical connection (open circuit). Since the device disables the open rows during the intermittent connection, one possible solution is, on the customer side, to toggle the EN pin and verify if the fault condition is still present.

In fact, once you disconnect one row, it will result as a off-row (Fault -> open row, latched). When you connect it again, it is as a shorted led ( $V_{row}$  higher than the threshold).

This is because the short led detection is still active.

If the fault disappears after toggling the EN pin, it means that the connection is again on and the problem can be detected as a previous intermittent connection.

If the fault persists also after toggling the EN pin, it means that the problem is on the leds (one or more open leds) or on the flat cable or the cable connector (broken wire).

The resultant Fault Management table will be:

**Table 9. Intermittent connection faults management summary**

FAULT	MODE to GND	MODE to VCC
Internal MOSFET over current	FAULT pin HIGH power-MOS turned OFF	FAULT pin HIGH power-MOS turned OFF
Output over voltage	FAULT pin LOW device turned OFF latched	FAULT pin LOW device turned OFF latched
Thermal shutdown	FAULT pin LOW device turned OFF latched	FAULT pin LOW device turned OFF latched
Shorted LED on a single row	FAULT pin LOW faulty ROW DISABLED VTH,FAULT = 8.2 V	FAULT pin LOW faulty ROW DISABLED VTH,FAULT = 8.2 V
Shorted LEDs on more row	FAULT pin LOW device latched OFF VTH,FAULT = 8.2 V	FAULT pin LOW faulty ROWs DISABLED VTH,FAULT = 8.2 V
Open row	FAULT pin LOW faulty ROW DISABLED	FAULT pin LOW faulty ROW DISABLED
More than one open rows	FAULT pin LOW device latched OFF	FAULT pin LOW faulty ROWs DISABLED
Open row plus shorted LED (different rows)	FAULT pin LOW device latched OFF VTH,FAULT = 8.2 V	FAULT pin LOW faulty ROWs DISABLED VTH,FAULT = 8.2 V

## 10 Package mechanical data

In order to meet environmental requirements, ST offers these devices in different grades of ECOPACK<sup>®</sup> packages, depending on their level of environmental compliance. ECOPACK<sup>®</sup> specifications, grade definitions and product status are available at: [www.st.com](http://www.st.com). ECOPACK<sup>®</sup> is an ST trademark.

**Table 10. VFQFPN-24 mechanical data**

Dim.	Min	Typ	Max
A	0.80	0.90	1.00
A1	0.00	0.02	0.05
A3		0.20	
b	0.18	0.25	0.30
D	3.85	4.00	4.15
D2	2.40	2.50	2.60
E	3.85	4.00	4.15
E2	2.40	2.50	2.60
e		0.50	
L	0.30	0.40	0.50
ddd			0.08

Figure 53. VFQFPN-24 mechanical data

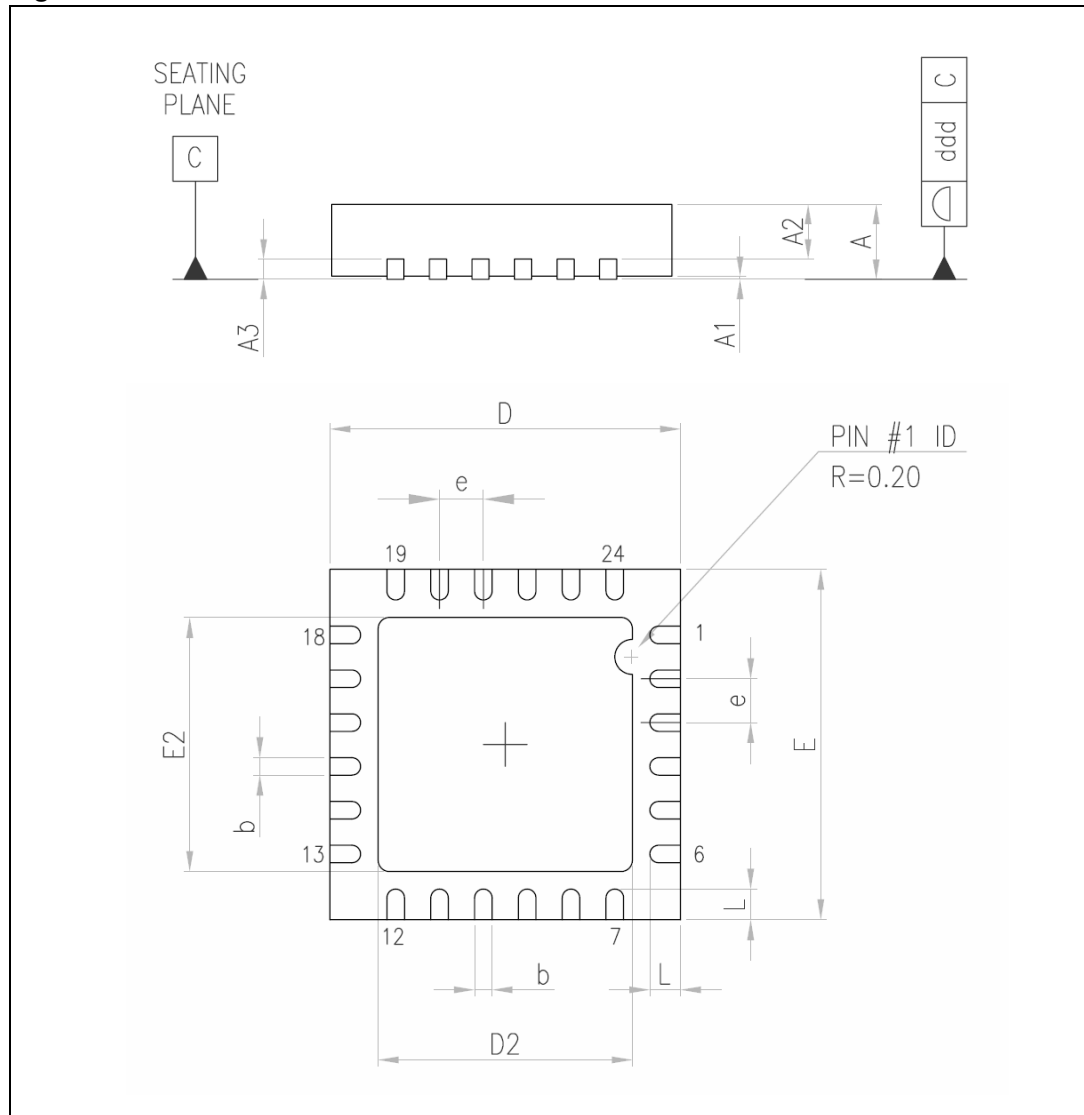

## Appendix A Layout guidelines

### A.1 Basic points:

- The device thermal pad is SGND.
- The device has 2 GND pins: SGND and PGND

#### A.1.1 GNDs planes - 1 device

If the pcb has 2 layers, the PGND area has to be in the top layer, together with the LX area and the Vin and Vout area, in order to reduce the number of the vias.

The SGND plane is the bottom layer of the board and it is also present near the signal components on the top layer.

The SGND and PGND connection can be made using the thermal pad of the device.

If the pcb has 4 layers, the PGND and SGND planes must be separated into 2 different layers. Moreover, they must be connected together in only 1 point, near the PGND pin of the device. It is recommended to duplicate the LX area into one inner layer, to reduce the impedance and improve the noise rejection immunity of the device.

If the PM6600 device is mounted on a more complex demonstration board (ex. RGB, multi-device application, LCD driver + backlight driver board), the PGND and SGND connection should be present only near the PGND pin of the device. This is relevant in complex systems because of the possible cross-talking noise between each block of the system.

In order to connect together the PGND and SGND nets, it is not advisable to use a  $0\ \Omega$  resistor, because it can produce a voltage drop between the two GNDs planes and it may damage the device.

It is preferable to connect together the PGND and SGND to the thermal pad of the device, or with a short pcb trace near the PGND pin of the device.

#### A.1.2 GNDs planes - 3 devices (RGB)

The SGND plane is the same for all the PM6600 devices – bottom layer (or internal 2-3).

Each PM6600 device must have its own PGND area (top layer), connected to the main SGND in one point, near the PGND pin of each device > totally 3 connections between the SGND and PGND, 1 for each driver:

PGND\_red - SGND; PGND\_blue - SGND; PGND\_green - SGND.

### A.2 Compensation network

The components Rcomp – Ccomp of the compensation network should be as close as possible to the COMP pin of the device. This permits to avoid any noise issue - instability of the compensation.

This PCB trace should be designed in the opposite side of the device respect to the power area (according to the pins position). This subdivision improves the noise rejection of the system and permits to have a stable loop.

Take care not to design the LX switching copper area near the COMP network, in order to avoid cross-talking between the power switching signal and the compensation one.

A very important thing is to keep the feedbacks (ROWS) and compensation traces as short as possible to minimize noise pick up and to keep them away from noise or field sources (the switch, diode, inductor). The feedbacks and compensation traces should never pass under the inductor, switch or diode (even if on opposite sides of the PCB). They should not run close to and parallel to a noisy (power critical) trace.

### A.3 LX area – vout power area

The LX Switching node area should be properly dimensioned  $\mp$  large and short enough to assure a noise-free working. The power loop of LX, inductor, PGND must be as short as possible, by mounting L, D, Cout as close as possible one each other. The power area should be positioned away from the critical signals (mainly the compensation network).

The L, D, Cout components are in the power critical path.

The Cin position is less important than the L, D, Cout. However, it is preferable to have all the power components in the same side of the device, to reduce the power path length and to avoid noise coupling between power and signal traces.

### A.4 Overvoltage divider

Since the PM6600 works with a compensated divider connected to the OVSEL pin to set the Overvoltage threshold, the two capacitors should be mounted as close as possible to the OVSEL pin of the device.

Then you can choose the resistors position near of them.

In the standard PM6600 demonstration board, the capacitors and resistors position is swapped. This was done because of the need to test the application in different working conditions.

The capacitors have the priority in the positioning because they clean the OVSEL signal of the noise caused by the LX switching node.

### A.5 LDO5 – AVCC filter

The 2 capacitors should be mounted as close as possible to the LDO5 and VCC pins of the device. The resistor has to be mounted near of them or it can be omitted (short) where the PCB dimensions are very small.

### A.6 ROWs current generators

The ROWs current generators are referred to SGND. In order to assure the best performances for current accuracy/mismatch the PCB traces lengths from the ROWs pins to the LEDs should be the same for all the current generators.

### A.7 Top layer of the standard PM6600 demonstration board

While referring to the PM6600EVAL\_EN demonstration board, the PGND and SGND connections are more than one. In this case the PGND and SGND areas are separated in the top layer (see Figure 1), while the bottom layer of the demonstration board is a unique GND plane connected to SGND and PGND with the vias on the thermal pad and the vias inside the test points.

Since the PM6600EVAL\_EN demonstration board is an isolated system, there are no cross-talking issues between the GNDs areas.

When the device is mounted on a LCD board, together with other devices (digital, analog and power ones), it is very important to properly follow the layout guidelines listed above, in order to dedicate to each device the PGND and SGND portion of the entire board.

In the picture below:

- COMP > green
- Vin > dark blue
- LX > blue
- Vout > light blue
- PGND > light yellow
- SGND > dark yellow

Figure 54. Top layer critical signals components assembly and layout

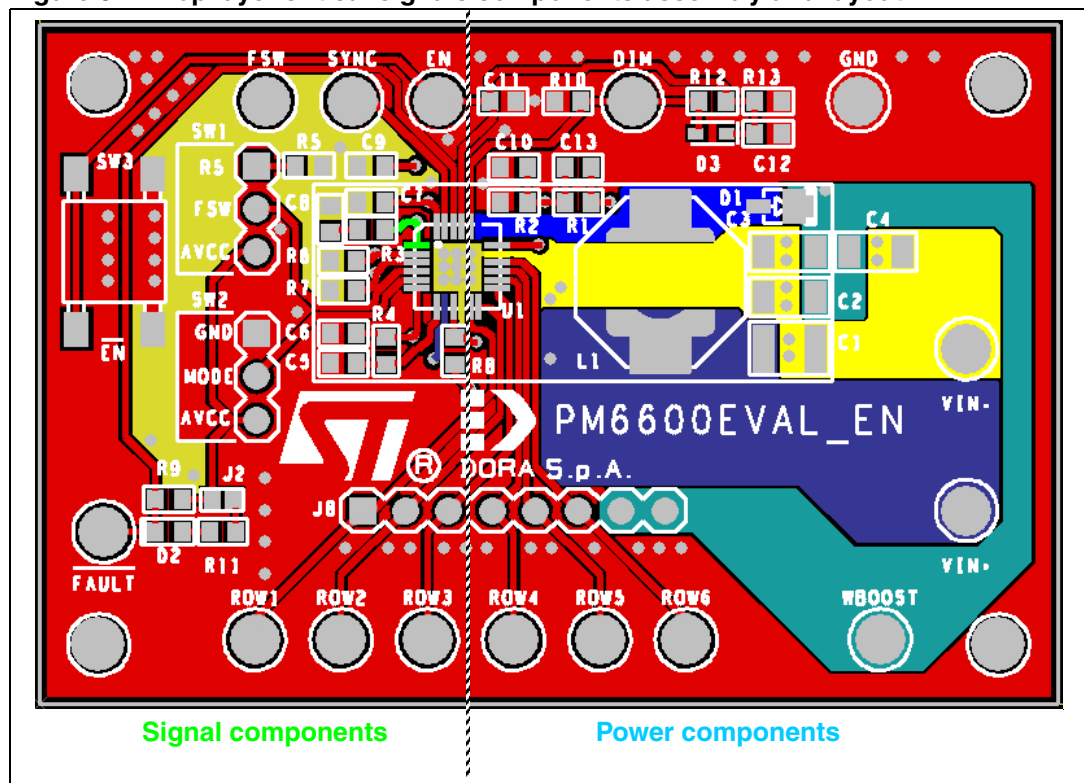

The following pictures are the Gerber files of the PM6600EVAL\_EN board.

Figure 55. Top side

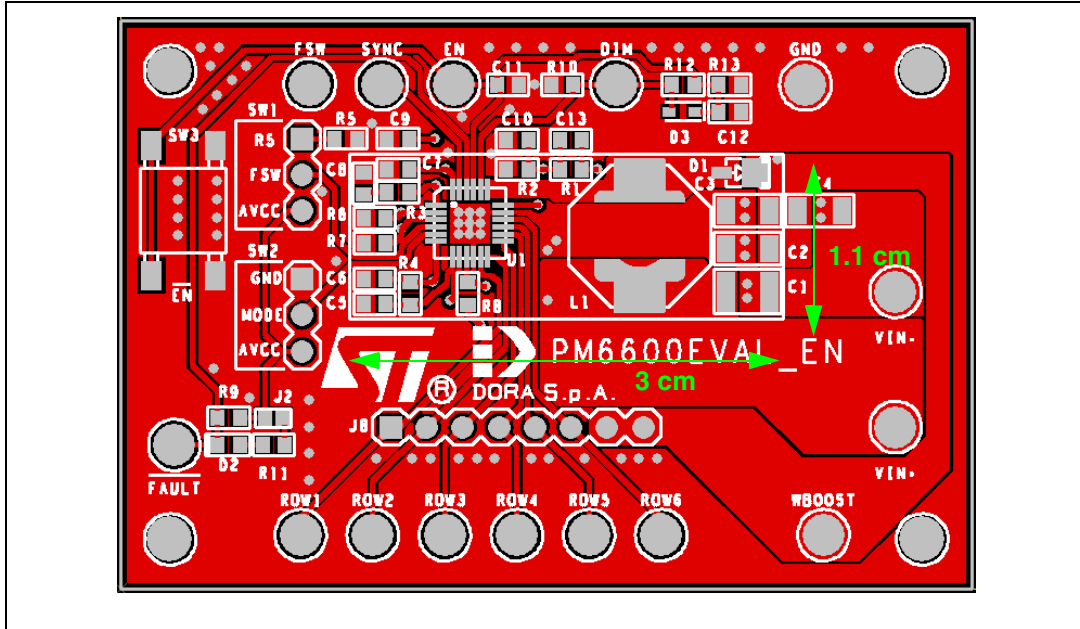
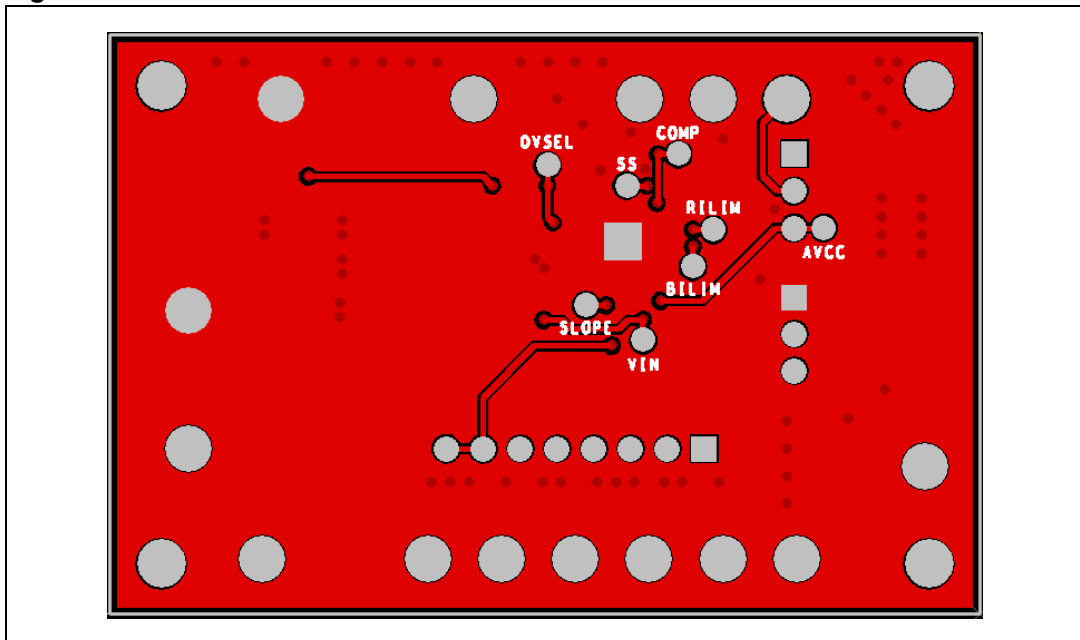

Figure 56. Bottom side



Vias specs: diameter 0.8 mm, hole 0.3 mm

## Appendix B Application note

### B.1 Inductor selection

Being the PM6600 mostly dedicated to notebook backlighting, real-estate applications dictate severe constrain in selecting the optimal inductor. The inductor choice must take into account different parameters like conduction losses (DCR), core losses (ferrite or iron-powder), saturation current and magnetic-flux shielding (core shape and technology).

The switching frequency of the PM6600 can be set in the 200 kHz-1 MHz range, allowing a wide selecting room for the inductance value. Low switching frequencies takes to high inductance value, resulting in significant DCR and size. On the other hand, high switching frequencies result in significant core losses. The suggested range is 4.7-22  $\mu\text{H}$ , even if the best trade off between the different loss contributions varies from manufacturer to manufacturer.

A 6.8  $\mu\text{H}$  inductor has been experimentally found as the most suitable for applications running at a 660 kHz switching frequency.

### B.2 Capacitors selection

The input and output capacitors should have very low ESR (ceramic capacitors) in order to minimize the ripple voltage. The boost converter of the PM6600 has been designed to support ceramic capacitors. The required capacitance depends on the programmed LED current and the minimum dimming frequency (the boost converter is off when the DIM pin is low and the output capacitor is slowly discharged). Considering the worst case (i.e. 200 Hz dimming frequency and 30mA/channel), two 2.2  $\mu\text{F}$  MLCCs are suitable for almost all applications. Particular care must be taken when selecting the rated voltage and the dielectric type of the output capacitors: 50 V rated MLCC may show a significant capacitance drop when biased, especially in case of Y5V dielectric.

As in most of boost converters, the input capacitor is less critical, although it is necessary to reduce the switching noise on the supply rail. The input capacitor is also important for the internal LDO of the PM6600 and must be kept as close as possible to the chip. The rated voltage of the input capacitor can be chosen according to the supply voltage range; a 10  $\mu\text{F}$  X5R MLCC is recommended.

### B.3 Flywheel diode selection

The flywheel diode must be a Schottky type to minimize the losses. This component is subject to an average current equal to the output one and must sustain a reverse voltage equal to the maximum output rail voltage. Considering all the channels sinking 30 mA each (i.e. 180 mA output current) and the maximum output voltage (36 V), the STPS1L40M ( $I_{f,ave} = 1 \text{ A}$ ,  $V_r = 40 \text{ V}$ ) diode is a good choice. Smaller diodes can be used in applications involving lower output voltage and/or lower output current.

## B.4 Design example

In order to help the design of an application using the PM6600, in this section a simple step-by-step design example is provided.

A typical application could be the LCD backlight in a 14.1" LCD panel using the PM6600.

Here below the possible application conditions are listed:

- $V_{IN} = 12 \pm 20\%$
- 6 ROWs x 8 WLEDs @ 20 mA
- $V_{F, LEDs} = 3.5 V \pm 200 mV$

### B.4.1 Switching frequency setting

To reduce the number of the external components, the default switching frequency is selected (660 kHz typ.) by connecting the FSW pin to AVCC pin.

However, in case a different switching frequency is required, a resistor from FSW pin and ground can be connected, according to the equation

**Equation 22**

$$R_{FSW} = \frac{F_{SW}}{2.5}$$

### B.4.2 Row current setting

The ROWs current is set using a resistor connected to the RILIM pin of the device. The  $R_{RILIM}$  resistor can be calculated as:

**Equation 23**

$$R_{RILIM} = \frac{K_R}{I_{ROW}} = \frac{998}{20} \frac{V}{mA} = 49.9k\Omega$$

### B.4.3 Inductor choice

The boost section, as all DC-DC converters, can work in CCM (continuous conduction mode) or in DCM (discontinuous conduction mode) depending on load current, input and output voltage and other parameters, among which the inductor value.

In a boost converter it is usually preferable to work in DCM.

Once the load, the input and output voltage, and the switching frequency are fixed, the inductor value defining the boundary between DCM and CCM operation can be calculated as:

**Equation 24**

$$L_B = \frac{R_0 \cdot D \cdot (1-D)^2}{2 \cdot F_{SW}}$$

where D is the duty-cycle defined as:

**Equation 25**

$$D = 1 - \frac{V_{IN}}{V_{OUT}} = \begin{cases} 0.68 & @ V_{IN,min} = 9.6V \\ 0.52 & @ V_{IN,max} = 14.4V \end{cases}$$

whereas  $R_0$  is:

**Equation 26**

$$R_0 = \frac{V_{OUT}}{I_{OUT}} = 250\Omega$$

and

**Equation 27**

$$I_{OUT} = 6 \cdot I_{ROW} = 120mA$$

The output voltage in the above calculations is considered as the maximum value (LED with the maximum forward voltage connected to the leading generator):

**Equation 28**

$$V_{OUT,max} = 8 \cdot V_{F,LEDs,max} + 400mV = 30V$$

**Figure 57. Inductor current in DCM operation**

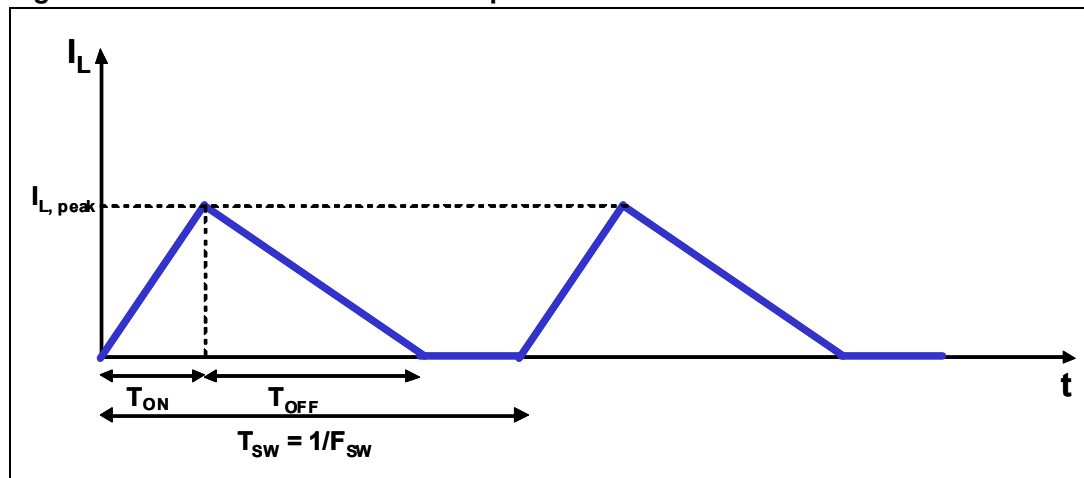

Considering the input voltage range, the lower  $L_B$  will be at the lower input voltage. Hence the condition to assure the DCM operation becomes:

**Equation 29**

$$L < L_B(V_{IN,min}) = 13.2\mu H$$

An inductor value of 6.8  $\mu H$  could be a suitable value, considering also a margin from the boundary condition.

It is important to highlight that the inductor choice involves not only the value itself but the saturation current (higher than the boost current limit), the rated RMS current (the compliance with the saturation current might be not enough; also the thermal performances must be taken into account), the DCR (which affects the efficiency) and the size (in some application might be a strict requirement).

However the DCR can't be reduced keeping the size small. Hence a trade off between these two requirements must be achieved according to the application.

#### B.4.4 Output capacitor choice

The choice of the output capacitor is mainly affected by the desired output voltage ripple.

Since the voltage across the LEDs can be considered almost constant, this ripple is transferred across the current generators, affecting their dynamic response.

The output ripple can be estimated as (neglecting the contribution of ESR of  $C_{OUT}$ , very low in case of MLCC):

##### Equation 30

$$\Delta V_{OUT} = \frac{(I_{L,peak} - I_{OUT}) \cdot T_{OFF}}{2 \cdot C_{OUT}}$$

where  $I_{L, peak}$  is the inductor peak current (see Figure 1) calculated as:

##### Equation 31

$$I_{L,peak} = \frac{V_{IN} \cdot D}{F_{sw} \cdot L} = \begin{cases} 1.044A & @ V_{IN,min} = 9.6V \\ 0.914A & @ V_{IN,max} = 14.4V \end{cases}$$

whereas D, working in DCM, is:

##### Equation 32

$$D = \sqrt{\frac{2 \cdot F_{sw} \cdot L \cdot M(M-1)}{R_0}} = \begin{cases} 0.488 & @ V_{IN,min} = 9.6V \\ 0.285 & @ V_{IN,max} = 14.4V \end{cases}$$

defining M as:

##### Equation 33

$$M = \frac{V_{OUT}}{V_{IN}} = \begin{cases} 3.125 & @ V_{IN,min} = 9.6V \\ 2.083 & @ V_{IN,max} = 14.4V \end{cases}$$

$T_{OFF}$  can be calculated as:

##### Equation 34

$$T_{OFF} = T_{sw} \cdot D_2 = \begin{cases} 348.5ns & @ V_{IN,min} = 9.6V \\ 398.5ns & @ V_{IN,max} = 14.4V \end{cases}$$

defining  $D_2$  as:

$$D_2 = \sqrt{\frac{2 \cdot F_{SW} \cdot L \cdot M}{R_0 \cdot (M-1)}} = \begin{cases} 0.23 & @ \ V_{IN,min} = 9.6V \\ 0.263 & @ \ V_{IN,max} = 14.4V \end{cases}$$

The worst case for the output voltage ripple is when input voltage is lower ( $V_{IN,min} = 9.6 V$ ).

A simple way to select the  $C_{OUT}$  value is fixing a maximum voltage ripple.

In order to affect as less as possible the current generators, it would be better to fix the maximum ripple lower than the typical voltage across the generators.

For example considering  $\Delta V_{OUT}$  lower than 80 mV (i.e. the 20% of the voltage across the leading generator), the required capacitance is:

#### Equation 35

$$C_{OUT} > \frac{(I_{L,peak} - I_{OUT}) \cdot T_{OFF}}{2 \cdot \Delta V_{OUT,max}} = 2.02 \mu F$$

A margin from the calculated value should be taken into account because of the capacitance drop due to the applied voltage when MLCCs are used.

A 4.7  $\mu F$  MLCC can be a good choice for this application (two 2.2  $\mu F$  MLCC in parallel can be also a good solution).

In case a dimming duty cycle different from 100% is used, a further contribution to the capacitor discharge (during the off time of the dimming cycle) should be considered.

### B.4.5 Input capacitor choice

The input capacitor of a boost converter is less critical than the output capacitor, due to the fact that the inductor is in series with the input, and hence, the input current waveform is continuous.

A low ESR capacitor is always recommended.

A capacitor of 10  $\mu F$  is tentatively a good choice for most of the applications.

### B.4.6 Overvoltage protection divider setting

The overvoltage protection (OVP) divider provides a partition of the output voltage to the OVSEL pin. The OVP divider setting not only fixes the OVP threshold, but also the open-channel detection threshold (93% of the OVP threshold).

The proper OVP divider setting can be calculated by the equation:

#### Equation 36

$$R_1 = R_2 \left( \frac{V_{OVP}}{1.235} - 1 \right)$$

$V_{OVP}$  has to be chosen in the range

**Equation 37**

$$V_{OUTmax} + 3V < V_{OVP} < V_{OUTmax} + 4.5V$$

Where

**Equation 38**

$$V_{OUTmax} = n_{WLED\_series} \cdot V_{F\_WLEDmax} + 400mV = 30V$$

$R_1$  can be chosen is in the order of hundreds of kilo-ohms to reduce the leakage current in the resistor divider. For example, setting  $R_2 = 15\text{ k}\Omega$  leads to  $R_1 = 390\text{ k}\Omega$  ( $V_{OVP} = 33.5\text{ V}$ ).

The OVSEL divider capacitors should be chosen according to the formula

**Equation 39**

$$C_{13} = 1.5 \cdot C_{10} \cdot \frac{R_2}{R_1}$$

For most cases,  $C_{10} = 220\text{ pF}$  and  $C_{13} = 22\text{ pF}$  are recommended.

#### B.4.7 Compensation network

For the compensation network, the suggestions provided in section 7.4 are always valid.

The following value of  $R_3$  and  $C_8$  are usually a good choice for the loop stability:

$$R_3 = 2.4\text{ k}\Omega$$

$$C_8 = 4.7\text{ nF}$$

These values are correct when working with 6 ROWs. For applications using less than 4 ROWs it is recommended to calculate again the value of the compensation components. Please refer to the [Table 11 on page 54](#) for a detailed components check

#### B.4.8 Boost current limit

The boost current limit is set to protect the internal power switch against excessive current. The slope compensation may reduce the programmed current limit. Hence, to take into account this effect, as a rule of thumb, the current limit can be set as twice as much the maximum inductor peak current (see section 1.2.4):

$$I_{BOOST, PEAK} > 2.09\text{ A}$$

Therefore choosing  $I_{BOOST, PEAK} = 2.5\text{ A}$ ,  $R_{BILIM}$  will be:

**Equation 40**

$$R_{BILIM} = \frac{K_B}{I_{BOOST, PEAK}} = 240\text{k}\Omega$$

### B.4.9 Soft-start

The SS duration is set connecting a capacitor between the SS pin and GND. The capacitor is thus charged with a constant 5  $\mu$ A current, forcing the SS pin voltage to ramp up.

The current limit of the internal power-MOS is proportionally released. It reached the set value when the voltage on the SS pin is 1.2 V.

During the initial part of the SS, the switching frequency is reduced to half of the set value. This is done to avoid current runaway due to the minimum on time of the switching controller. The switching frequency becomes the set one when the SS pin voltage is 0.8 V.

Since the current limit is been released proportionally, the changing of the switching frequency causes the output to increase with an higher slew-rate.

In order to avoid the output overshoot and to avoid a too high slew rate in the OVSEL pin voltage ramp, it is necessary to set up correctly the SS capacitors, taking into account all the working conditions (mainly  $V_{IN}$ ,  $I_{OUT}$ ,  $C_{OUT}$ , ILIM)

During the SS it is performed the floating ROWs detection.

When one or more ROWs are open, the output voltage increases until the OVSEL pin reaches the FRD threshold (93% of the OVP threshold). At this point the floating ROWs are internally excluded from the control loop and considered not connected.

When the SS pin reaches 2.4 V all the IC protections turn active. The latched OVP protection is activate as soon as the internal LDO regulates 5 V.

In order to properly dimension the  $C_{SS}$  value, it should be considered the two cases: 6 ROWs application and less than 6 ROWs application.

When working with 6 ROWs, the  $C_{SS}$  value should be chosen in the range 3.3 nF to 10 nF. Since the DIM signal is internally forced to 100% during the soft-start, a bigger  $C_{SS}$  results in a bigger WLEDs brightness that can be higher than the resultant one after the soft-start, when the ROWs current generators are driven with the applied external DIM signal.

When working with less than 6 ROWs, the application components should be chosen in order to avoid an OVP triggering due to the switching frequency change mechanism when  $SS = 0.8$  V. The suggested minimum value for  $C_{SS}$  is, in this case, 6.8 nF.

Moreover, the other critical components to change respect to the standard 6 ROWs application are

**Table 11. Components**

Component name	6 ROWs application	< 6 ROWs application
$C_{SS}$	3.3 nF	6.8 nF
$R_{BILIM}$	250 k $\Omega$	200 k $\Omega$
$R_{SLOPE}$	680 k $\Omega$	1 M $\Omega$
$R_{COMP}$	2.4 k $\Omega$	3.3 k $\Omega$
$C_{COMP}$	4.7 nF	3.3 nF

$C_{SS}$ ,  $R_{BILIM}$  and  $R_{SLOPE}$  components are changed to shift the time in which the frequency increases at the set value. The shift guarantees to avoid any  $V_{OUT}$  overshoot with  $V_{IN} > 10$  V.

$R_{COMP}$  and  $C_{COMP}$  are changed to lower the amplitude of the overshoot for  $7.5$  V <  $V_{IN}$  <  $10$  V. This avoids the occurrence of the latched OVP condition.

# Appendix C Application suggestions

## C.1 Full application schematic

Figure 58. Full application schematic

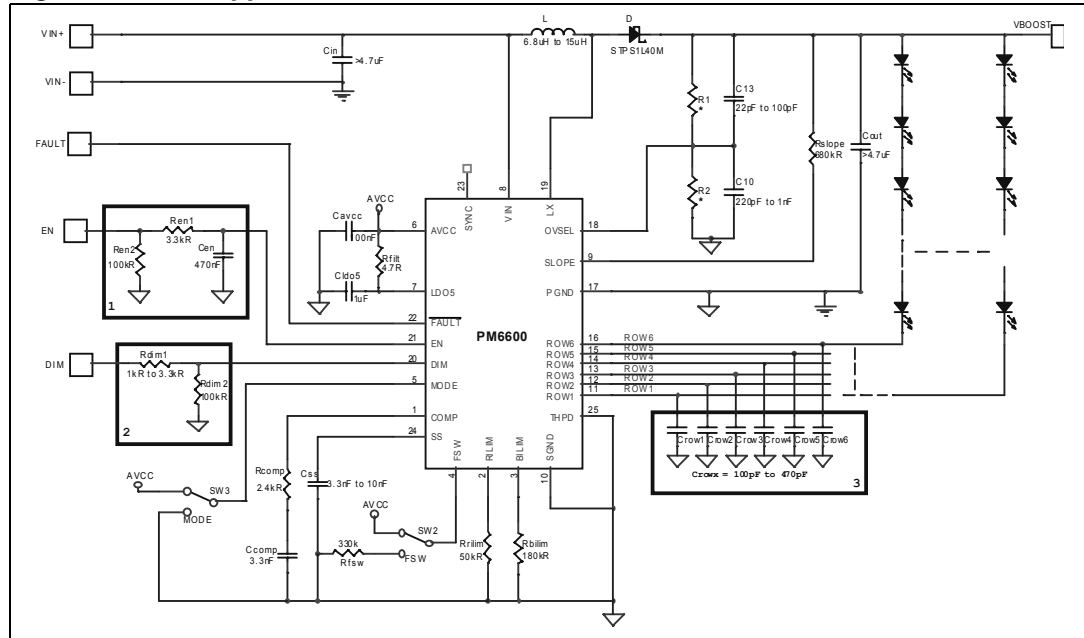

With respect to the Basic application circuit (see chapter1), some optional components are added. Below the suggestions, section by section, on why and in which cases to add these components.

## C.2 EN, DIM path in production line

Normally, in production line, the LCD modules are connected to testing machines with long wires. The VIN, EN and DIM signals are provided with automatic testing equipment, such as relays and/or software controlled switches, that connects the dedicated power supplies to the board.

The wires parasitic inductance can lead to voltage spikes conditions that can exceed the device maximum absolute ratings, thus resulting in a device damage.

In order to filter the critical signals, the suggestion is to add an RC network between the board connector and the device pin.

**Figure 59. EN pin filter**

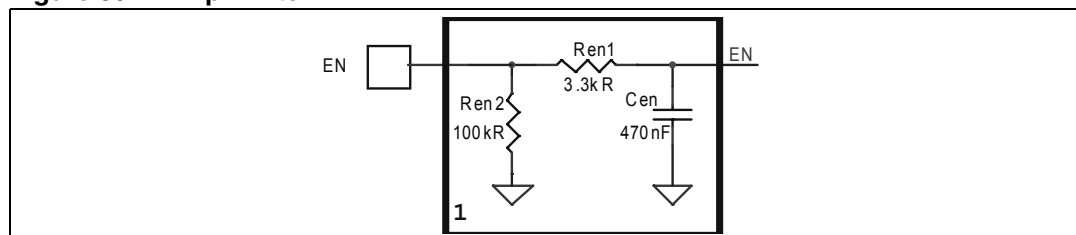

In case of the EN pin, the recommended power supply value is 3.3 V, and we also suggest to use an RC low pass filter network with  $R_{en1} = 3.3 \text{ k}\Omega$ ,  $C_{en} = 470 \text{ nF}$ .

If the EN is not externally driven, the PM6600 has an internal pull-up that permits to turn the device ON by leaving the EN pin floating. In case the external driving circuit is present, but it is not guaranteed that it drives the EN pin to a logic "0", an external pull-down resistor  $R_{en2}$  is needed.

**Figure 60. DIM pin filter**

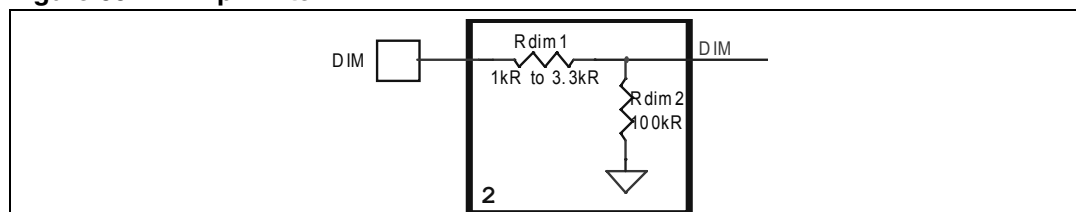

In the production line, the DIM signal is provided by a common power supply/signal generator to a set of LED driver boards under test. The use of long wires and relays can provoke spikes on the DIM pin, with a voltage level higher than the absolute maximum ratings of the device. In this case, the device is internally damaged and stops working properly.

To protect the DIM pin of the PM6600 device, a resistor  $R_{dim1}$  is needed. It prevents a large inrush current flowing into the device in case the voltage spike is exceeding the absolute maximum ratings.

In case the DIM signal is provided by a micro controller (in production line and/or in the final application), a pull-down resistor  $R_{dim2}$  can be needed. If the micro controller is not powered, it is possible that the voltage on the DIM pin of the PM6600 device will go to a logic high level, because of board noise or signals coupling. The pull-down resistor avoids this issue.

In case of the DIM pin, we suggest to use a function generator. In case of using a power supply, it is preferable to use 3.3 V and the same RC filter as the EN pin.

For what concerns the VIN pin, it is already filtered by the input capacitors.

### C.3 ROW pins protection

Figure 61. ROW pins protection

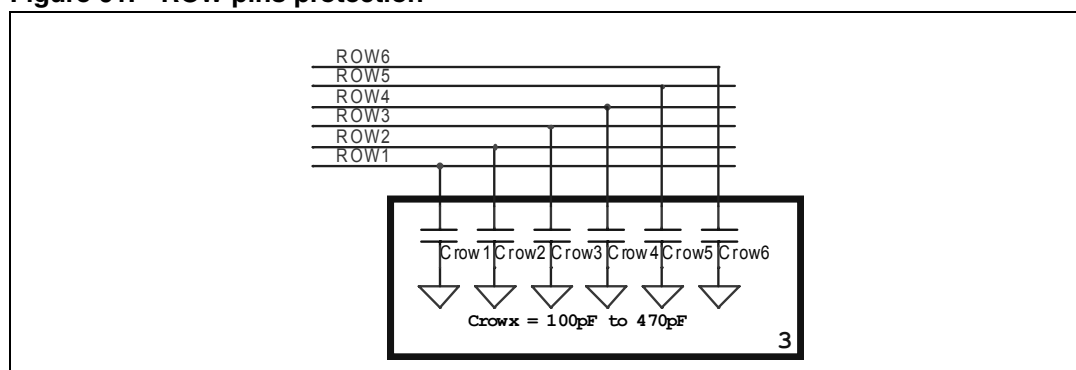

In the production line, the most common way to test the LED Driver PCB is to connect it to the LED Board using a Dummy LED Driver Board. The Dummy Board is connected to the LED Driver PCB by using metal needles, while it is directly connected to the LED Board.

The metal needles contacts, in case the board is not turned off while mounting/removing, can provoke a charge injection into the ROWs pins of the device, thus damaging it. The external capacitors, chosen in the range 100 pF to 470 pF, limits the voltage spike on the ROWs pins, avoiding the charge injection.

In order to limit the EOS induced stress on ROWx pins, 1 nF capacitor can be used. In this working conditions, please consider that the minimum on time of the current generator is increased, due to the external capacitors that reduce the current turn-on/off slew-rate.

The capacitors connected between the ROWs pins and SGND are also useful in case of ESD discharge on the ROWs pins bigger than the device specifications.

### C.4 Debug and measurements test points

The tests points used to check the functionality of the board during PCB assembly and/or in the production line can be dangerous in case of not-protected ESD environment or in case overvoltage or overcurrent, exceeding the absolute maximum ratings (AMR) of the device, hits them.

The critical pins involved are the ROWx pins. In case a testing machine is connected with needles on the ROWx pins test points, it can be possible that an ESD, exceeding AMR, occurs or it is possible that the testing machine creates an overvoltage/overcharge condition in the pin. In this case the device will result damaged.

The corrective action is to add, for every ROWx pin, 100 pF capacitor vs GND and to avoid the test points on the ROWx pins if not strictly necessary.

## C.5 Inductor choice

The inductor selection should be done according to the datasheet guidelines.

The choice of the inductor value is explained in the [Section B.4.3: Inductor choice on page 49](#).

Moreover, the inductor has to be properly dimensioned also according to the boost current limit, [Section B.4.8: Boost current limit on page 53](#)

When using low current rated inductors, the risk is to have the inductor saturating during the soft-start sequence or even during operating mode.

In case of saturation during the soft-start, the device can go into OVP and latch off. If the inductor is hard saturating, both in soft-start and in operating mode, the risk is to have the LX pin exceed the absolute maximum ratings. In this condition, the device will switch using the minimum on time of the boost controller, to avoid the output overcharge and to preserve the leds from issues. If the saturation is prolonged, the inductor is behaving as a wire (the inductance value will be extremely reduced). This will create inductor damage and/or device damage because of overstress condition.

# 11 Revision history

**Table 12. Document revision history**

Date	Revision	Changes
07-Dec-2007	1	Initial release
21-Jan-2008	2	Updated <a href="#">Table 4</a> , <a href="#">Table 5</a> and <a href="#">Table 6 on page 12</a>
07-Apr-2008	3	Updated <a href="#">Section 3.3 on page 11</a> and <a href="#">Section 8.2 on page 38</a>
20-Oct-2008	4	Updated <a href="#">Section 3.3 on page 11</a> and <a href="#">Section 8.2 on page 38</a> Added <a href="#">Section Appendix A on page 44</a> , <a href="#">Section Appendix C on page 55</a>
12-Feb-2009	5	Added <a href="#">Figure 58 on page 55</a> , <a href="#">Figure 60 on page 56</a> , <a href="#">Section C.1 on page 55</a> , <a href="#">Section C.3 on page 57</a>
29-Jun-2009	6	Updated <a href="#">Table 4 on page 10</a>
18-Feb-2010	7	Updated <a href="#">Section C.3 on page 57</a>

**Please Read Carefully:**

Information in this document is provided solely in connection with ST products. STMicroelectronics NV and its subsidiaries ("ST") reserve the right to make changes, corrections, modifications or improvements, to this document, and the products and services described herein at any time, without notice.

All ST products are sold pursuant to ST's terms and conditions of sale.

Purchasers are solely responsible for the choice, selection and use of the ST products and services described herein, and ST assumes no liability whatsoever relating to the choice, selection or use of the ST products and services described herein.

No license, express or implied, by estoppel or otherwise, to any intellectual property rights is granted under this document. If any part of this document refers to any third party products or services it shall not be deemed a license grant by ST for the use of such third party products or services, or any intellectual property contained therein or considered as a warranty covering the use in any manner whatsoever of such third party products or services or any intellectual property contained therein.

**UNLESS OTHERWISE SET FORTH IN ST'S TERMS AND CONDITIONS OF SALE ST DISCLAIMS ANY EXPRESS OR IMPLIED WARRANTY WITH RESPECT TO THE USE AND/OR SALE OF ST PRODUCTS INCLUDING WITHOUT LIMITATION IMPLIED WARRANTIES OF MERCHANTABILITY, FITNESS FOR A PARTICULAR PURPOSE (AND THEIR EQUIVALENTS UNDER THE LAWS OF ANY JURISDICTION), OR INFRINGEMENT OF ANY PATENT, COPYRIGHT OR OTHER INTELLECTUAL PROPERTY RIGHT.**

**UNLESS EXPRESSLY APPROVED IN WRITING BY AN AUTHORIZED ST REPRESENTATIVE, ST PRODUCTS ARE NOT RECOMMENDED, AUTHORIZED OR WARRANTED FOR USE IN MILITARY, AIR CRAFT, SPACE, LIFE SAVING, OR LIFE SUSTAINING APPLICATIONS, NOR IN PRODUCTS OR SYSTEMS WHERE FAILURE OR MALFUNCTION MAY RESULT IN PERSONAL INJURY, DEATH, OR SEVERE PROPERTY OR ENVIRONMENTAL DAMAGE. ST PRODUCTS WHICH ARE NOT SPECIFIED AS "AUTOMOTIVE GRADE" MAY ONLY BE USED IN AUTOMOTIVE APPLICATIONS AT USER'S OWN RISK.**

Resale of ST products with provisions different from the statements and/or technical features set forth in this document shall immediately void any warranty granted by ST for the ST product or service described herein and shall not create or extend in any manner whatsoever, any liability of ST.

ST and the ST logo are trademarks or registered trademarks of ST in various countries.

Information in this document supersedes and replaces all information previously supplied.

The ST logo is a registered trademark of STMicroelectronics. All other names are the property of their respective owners.

© 2010 STMicroelectronics - All rights reserved



STMicroelectronics group of companies

Australia - Belgium - Brazil - Canada - China - Czech Republic - Finland - France - Germany - Hong Kong - India - Israel - Italy - Japan - Malaysia - Malta - Morocco - Philippines - Singapore - Spain - Sweden - Switzerland - United Kingdom - United States of America

[www.st.com](http://www.st.com)

## Looking for pricing, stock, or lifecycle information?

Click below to explore more details on WIN SOURCE:

-  [View PM6600 on WIN SOURCE](#)
-  [STMicroelectronics](#) Information

## Optimize Your Supply Chain with WIN SOURCE Solutions

-  Global Sourcing Solution
-  Obsolete Management
-  Cost Control Management
-  Shortage Management
-  Alternative Solution
-  Excess Inventory Management