

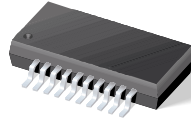

**THE DATASHEET OF  
PLL1708DBQ**





## 3.3-V DUAL PLL MULTICLOCK GENERATOR

### FEATURES

- 27-MHz Master Clock Input
- Generated Audio System Clock (PLL1707):
  - SCKO0:  $768 f_S$  ( $f_S = 44.1$  kHz)
  - SCKO1:  $768 f_S$ ,  $512 f_S$  ( $f_S = 48$  kHz)
  - SCKO2:  $256 f_S$  ( $f_S = 32, 44.1, 48, 64, 88.2, 96$  kHz)
  - SCKO3:  $384 f_S$  ( $f_S = 32, 44.1, 48, 64, 88.2, 96$  kHz)
- Generated Audio System Clock (PLL1708):
  - SCKO0:  $768 f_S$  ( $f_S = 44.1$  kHz)
  - SCKO1:  $768 f_S$ ,  $512 f_S$ ,  $384 f_S$ ,  $256 f_S$  ( $f_S = 48$  kHz)
  - SCKO2:  $256 f_S$  ( $f_S = 16, 22.05, 24, 32, 44.1, 48, 64, 88.2, 96$  kHz)
  - SCKO3:  $384 f_S$  ( $f_S = 16, 22.05, 24, 32, 44.1, 48, 64, 88.2, 96$  kHz)
- Zero PPM Error Output Clocks
- Low Clock Jitter: 50 ps (Typical)
- Multiple Sampling Frequencies (PLL1707):
  - $f_S = 32, 44.1, 48, 64, 88.2, 96$  kHz
- Multiple Sampling Frequencies (PLL1708):
  - $f_S = 16, 22.05, 24, 32, 44.1, 48, 64, 88.2, 96$  kHz
- 3.3-V Single Power Supply
- PLL1707: Parallel Control  
PLL1708: Serial Control
- Package: 20-Pin SSOP (150 mil), Lead-Free Product

### APPLICATIONS

- HDD + DVD Recorders
- DVD Recorders
- HDD Recorders
- DVD Players
- DVD Add-On Cards for Multimedia PCs
- Digital HDTV Systems
- Set-Top Boxes

### DESCRIPTION

The PLL1707<sup>†</sup> and PLL1708<sup>†</sup> are low cost, phase-locked loop (PLL) multiclock generators. The PLL1707 and PLL1708 can generate four system clocks from a 27-MHz reference input frequency. The clock outputs of the PLL1707 can be controlled by sampling frequency-control pins and those of the PLL1708 can be controlled through serial-mode control pins. The device gives customers both cost and space savings by eliminating external components and enables customers to achieve the very low-jitter performance needed for high performance audio DACs and/or ADCs. The PLL1707 and PLL1708 are ideal for MPEG-2 applications which use a 27-MHz master clock such as DVD recorders, HDD recorders, DVD add-on cards for multimedia PCs, digital HDTV systems, and set-top boxes.



This integrated circuit can be damaged by ESD. Texas Instruments recommends that all integrated circuits be handled with appropriate precautions. Failure to observe proper handling and installation procedures can cause damage.

ESD damage can range from subtle performance degradation to complete device failure. Precision integrated circuits may be more susceptible to damage because very small parametric changes could cause the device not to meet its published specifications.



Please be aware that an important notice concerning availability, standard warranty, and use in critical applications of Texas Instruments semiconductor products and disclaimers thereto appears at the end of this data sheet.

<sup>†</sup>The PLL1707 and PLL1708 use the same die and they are electrically identical except for mode control.

**FUNCTIONAL BLOCK DIAGRAM**

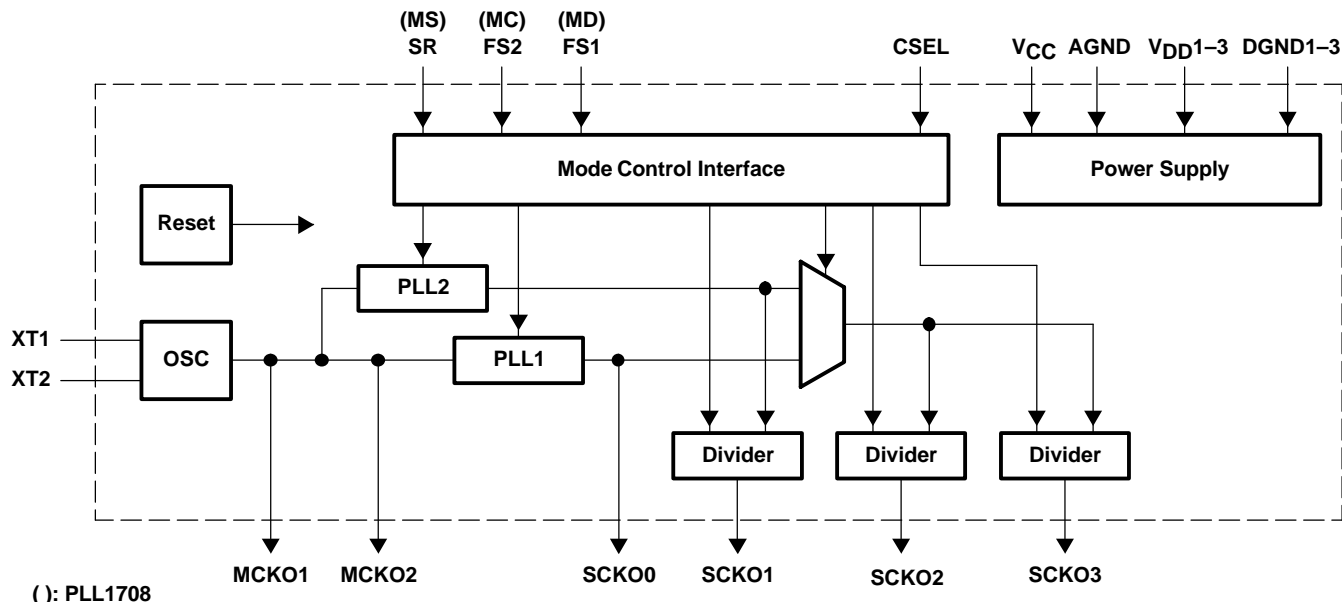

**PACKAGE/ORDERING INFORMATION**

PRODUCT	PACKAGE	PACKAGE CODE	OPERATION TEMPERATURE RANGE	PACKAGE MARKING	ORDERING NUMBER	TRANSPORT MEDIA
PLL1707DBQ	SSOP 20	20DBQ	-25°C to 85°C	PLL1707	PLL1707DBQ	Tube
					PLL1707DBQR	Tape and reel
PLL1708DBQ	SSOP 20	20DBQ	-25°C to 85°C	PLL1708	PLL1708DBQ	Tube
					PLL1708DBQR	Tape and reel

**ABSOLUTE MAXIMUM RATINGS**

over operating free-air temperature range unless otherwise noted<sup>(1)</sup>

	PLL1705 AND PLL1706
Supply voltage: $V_{CC}$ , $V_{DD1}$ - $V_{DD3}$	4 V
Supply voltage differences: $V_{CC}$ , $V_{DD1}$ - $V_{DD3}$	±0.1 V
Ground voltage differences: AGND, DGND1-DGND3	±0.1 V
Digital input voltage: FS1 (MD), FS2 (MC), SR (MS), CSEL	- 0.3 V to ( $V_{DD} + 0.3$ ) V
Analog input voltage, XT1, XT2	- 0.3 V to ( $V_{CC} + 0.3$ ) V
Input current (any pins except supplies)	±10 mA
Ambient temperature under bias	-40°C to 125°C
Storage temperature	-55°C to 150°C
Junction temperature	150°C
Lead temperature (soldering)	260°C, 5 s
Package temperature (IR reflow, peak)	260°C

<sup>(1)</sup> Stresses beyond those listed under "absolute maximum ratings" may cause permanent damage to the device. These are stress ratings only, and functional operation of the device at these or any other conditions beyond those indicated under "recommended operating conditions" is not implied. Exposure to absolute-maximum-rated conditions for extended periods may affect device reliability.

## ELECTRICAL CHARACTERISTICS

all specifications at  $T_A = 25^\circ\text{C}$ ,  $V_{DD1}-V_{DD3} (= V_{DD}) = V_{CC} = 3.3\text{ V}$ ,  $f_M = 27\text{ MHz}$ , crystal oscillation,  $f_S = 48\text{ kHz}$  (unless otherwise noted)

PARAMETER		TEST CONDITIONS		MIN	TYP	MAX	UNIT
<b>DIGITAL INPUT/OUTPUT</b>							
Logic input				CMOS compatible			
$V_{IH}^{(1)}$	Input logic level			$0.7V_{DD}$		3.6	Vdc
$V_{IL}^{(1)}$						$0.3V_{DD}$	
$I_{IH}^{(1)}$	Input logic current	$V_{IN} = V_{DD}$			65	100	$\mu\text{A}$
$I_{IL}^{(1)}$		$V_{IN} = 0\text{ V}$				$\pm 10$	
Logic output				CMOS			
$V_{OH}^{(2)}$	Output logic level	$I_{OH} = -4\text{ mA}$		$V_{DD} - 0.4\text{ V}$			Vdc
$V_{OL}^{(2)}$		$I_{OL} = 4\text{ mA}$				0.4	Vdc
Sampling frequency		PLL1707	Standard $f_S$	32	44.1	48	kHz
			Double $f_S$	64	88.2	96	
		PLL1708	Half $f_S$	16	22.05	24	
			Standard $f_S$	32	44.1	48	
			Double $f_S$	64	88.2	96	
<b>MASTER CLOCK (MCKO1, MCKO2) CHARACTERISTICS</b> ( $f_M = 27\text{ MHz}$ , $C_1 = C_2 = 15\text{ pF}$ , $C_L = 20\text{ pF}$ on measurement pin)							
Master clock frequency				26.73	27	27.27	MHz
$V_{IH}$	Input level(3)			$0.7V_{CC}$			V
$V_{IL}$				$0.3V_{CC}$			
$I_{IH}$	Input current(3)	$V_{IN} = V_{CC}$				$\pm 10$	$\mu\text{A}$
$I_{IL}$		$V_{IN} = 0\text{ V}$				$\pm 10$	
Output voltage (4)				3.5			Vp-p
Output rise time		20% to 80% of $V_{DD}$		2.0			ns
Output fall time		80% to 20% of $V_{DD}$		2.0			ns
Duty cycle		For crystal oscillation		45%	51%	55%	
		For external clock		50%			
Clock jitter (5)				50			ps
Power-up time (6)				0.5		1.5	ms
<b>PLL AC CHARACTERISTICS (SCKO0-SCKO3)</b> ( $f_M = 27\text{ MHz}$ , $C_L = 20\text{ pF}$ on measurement pin)							
SCKO0	Output system clock frequency	PLL1707	Fixed	33.8688			MHz
SCKO1			Selectable for 48 kHz	24.576		36.864	
SCKO2			256 $f_S$	8.192	12.288	24.576	
SCKO3			384 $f_S$	12.288	18.432	36.864	
SCKO0		PLL1708	Fixed	33.8688			
SCKO1			Selectable for 48 kHz	12.288	24.576	36.864	
SCKO2			256 $f_S$	4.096	12.288	24.576	
SCKO3			384 $f_S$	6.144	18.432	36.864	
Output rise time		20% to 80% of $V_{DD}$		2.0			ns
Output fall time		80% to 20% of $V_{DD}$		2.0			ns
Output duty cycle				45	50	55	%

(1) Pins 5, 6, 7, 12: FS1/MD, FS2/MC, SR/MS, CSEL (Schmitt-trigger input with internal pulldown, 3.3-V tolerant)

(2) Pins 2, 3, 14, 15, 18, 19: SCKO2, SCKO3, MCKO1, MCKO2, SCKO0, SCKO1

(3) Pin 10: XT1

(4) Pin 11: XT2

(5) Jitter performance is specified as standard deviation of jitter for 27-MHz crystal oscillation and default SCKO frequency setting. Jitter performance varies with master clock mode, SCKO frequency setting and load capacitance on each clock output.

(6) The delay time from power on to oscillation

(7) The settling time when the sampling frequency is changed

(8) The delay time from power on to lockup

(9)  $f_M = 27\text{-MHz}$  crystal oscillation, no load on MCKO1, MCKO2, SCKO0, SCKO1, SCKO2, SCKO3. Power supply current varies with sampling frequency selection and load condition.

(10) While all bits of CE[6:1] are 0, the PLL1708 goes into power-down mode.

### ELECTRICAL CHARACTERISTICS (continued)

all specifications at  $T_A = 25^\circ\text{C}$ ,  $V_{DD1}\text{--}V_{DD3} (= V_{DD}) = V_{CC} = 3.3\text{ V}$ ,  $f_M = 27\text{ MHz}$ , crystal oscillation,  $f_S = 48\text{ kHz}$  (unless otherwise noted)

PARAMETER	TEST CONDITIONS	MIN	TYP	MAX	UNIT	
Output clock jitter (5)	SCKO0, SCKO1		58	100	ps	
	SCKO2, SCKO3		50	100	ps	
Frequency Settling Time(7)	PLL1707, to stated output frequency		50	150	ns	
	PLL1708, to stated output frequency		80	300		
Power-up time (8)	To stated output frequency		3	6	ms	
<b>POWER SUPPLY REQUIREMENTS</b>						
$V_{CC}, V_{DD}$	Supply voltage range	2.7	3.3	3.6	Vdc	
$I_{DD} + I_{CC}$	Supply current (9)	$V_{DD} = V_{CC} = 3.3\text{ V}, f_S = 48\text{ kHz}$		19	25	mA
		Power down(10)		350	550	$\mu\text{A}$
	Power dissipation	$V_{DD} = V_{CC} = 3.3\text{ V}, f_S = 48\text{ kHz}$		63	90	mW
<b>TEMPERATURE RANGE</b>						
	Operating temperature	-25		85	$^\circ\text{C}$	
$\theta_{JA}$	Thermal resistance	PLL1707/8DBQ: 20-pin SSOP (150 mil)			150	$^\circ\text{C/W}$

(1) Pins 5, 6, 7, 12: FS1/MD, FS2/MC, SR/MS, CSEL (Schmitt-trigger input with internal pulldown, 3.3-V tolerant)

(2) Pins 2, 3, 14, 15, 18, 19: SCKO2, SCKO3, MCKO1, MCKO2, SCKO0, SCKO1

(3) Pin 10: XT1

(4) Pin 11: XT2

(5) Jitter performance is specified as standard deviation of jitter for 27-MHz crystal oscillation and default SCKO frequency setting. Jitter performance varies with master clock mode, SCKO frequency setting and load capacitance on each clock output.

(6) The delay time from power on to oscillation

(7) The settling time when the sampling frequency is changed

(8) The delay time from power on to lockup

(9)  $f_M = 27\text{-MHz}$  crystal oscillation, no load on MCKO1, MCKO2, SCKO0, SCKO1, SCKO2, SCKO3. Power supply current varies with sampling frequency selection and load condition.

(10) While all bits of CE[6:1] are 0, the PLL1708 goes into power-down mode.

### PIN ASSIGNMENTS

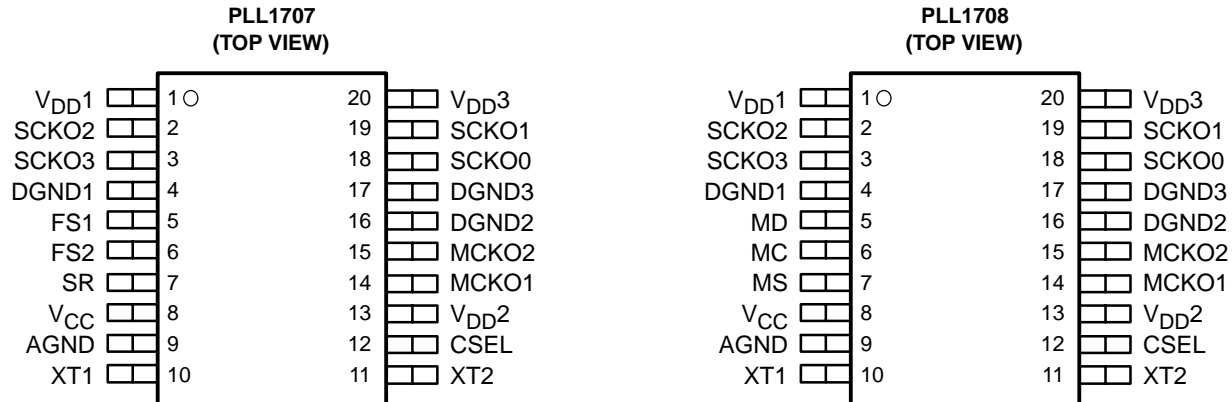

**PLL1707 Terminal Functions**

TERMINAL		I/O	DESCRIPTION
NAME	NO.		
AGND	9	–	Analog ground
CSEL	12	I	SCKO1 frequency selection control <sup>(1)</sup>
DGND1	4	–	Digital ground 1
DGND2	16	–	Digital ground 2
DGND3	17	–	Digital ground 3
FS1	5	I	Sampling frequency group control 1 <sup>(1)</sup>
FS2	6	I	Sampling frequency group control 2 <sup>(1)</sup>
MCKO1	14	O	27-MHz master clock output 1
MCKO2	15	O	27-MHz master clock output 2
SCKO0	18	O	System clock output 0 (33.8688 MHz fixed)
SCKO1	19	O	System clock output 1 (selectable for 48 kHz)
SCKO2	2	O	System clock output 2 (256 f <sub>S</sub> selectable)
SCKO3	3	O	System clock output 3 (384 f <sub>S</sub> selectable)
SR	7	I	Sampling rate control <sup>(1)</sup>
V <sub>CC</sub>	8	–	Analog power supply, 3.3 V
V <sub>DD1</sub>	1	–	Digital power supply 1, 3.3 V
V <sub>DD2</sub>	13	–	Digital power supply 2, 3.3 V
V <sub>DD3</sub>	20	–	Digital power supply 3, 3.3 V
XT1	10	I	27-MHz crystal oscillator, or external clock input
XT2	11	O	27-MHz crystal oscillator, must be OPEN for external clock input mode

<sup>(1)</sup> Schmitt-trigger input with internal pulldown.

PLL1708 Terminal Functions

TERMINAL NAME	NO.	I/O	DESCRIPTION
AGND	9	–	Analog ground
CSEL	12	I	SCKO1 frequency selection control <sup>(1)</sup>
DGND1	4	–	Digital ground 1
DGND2	16	–	Digital ground 2
DGND3	17	–	Digital ground 3
MC	6	I	Bit clock input for serial control <sup>(1)</sup>
MCKO1	14	O	27-MHz master clock output 1
MCKO2	15	O	27-MHz master clock output 2
MD	5	I	Data input for serial control <sup>(1)</sup>
MS	7	I	Chip select input for serial control <sup>(1)</sup>
SCKO0	18	O	System clock output 0 (33.8688 MHz fixed)
SCKO1	19	O	System clock output 1 (selectable for 48 kHz)
SCKO2	2	O	System clock output 2 (256 f <sub>S</sub> selectable)
SCKO3	3	O	System clock output 3 (384 f <sub>S</sub> selectable)
VCC	8	–	Analog power supply, 3.3 V
VDD1	1	–	Digital power supply 1, 3.3 V
VDD2	13	–	Digital power supply 2, 3.3 V
VDD3	20	–	Digital power supply 3, 3.3 V
XT1	10	I	27-MHz crystal oscillator, or external clock input
XT2	11	O	27-MHz crystal oscillator, must be OPEN for external clock input mode

(1) Schmitt-trigger input with internal pulldown.

TYPICAL PERFORMANCE CURVES

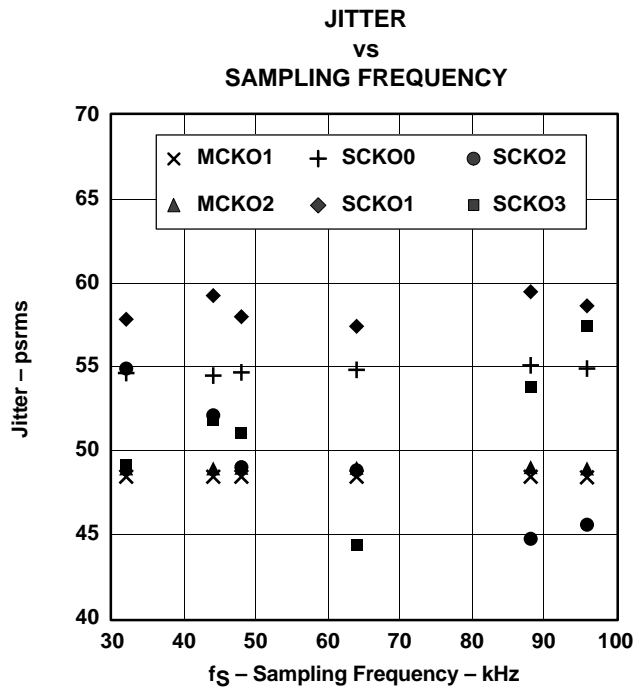

Figure 1

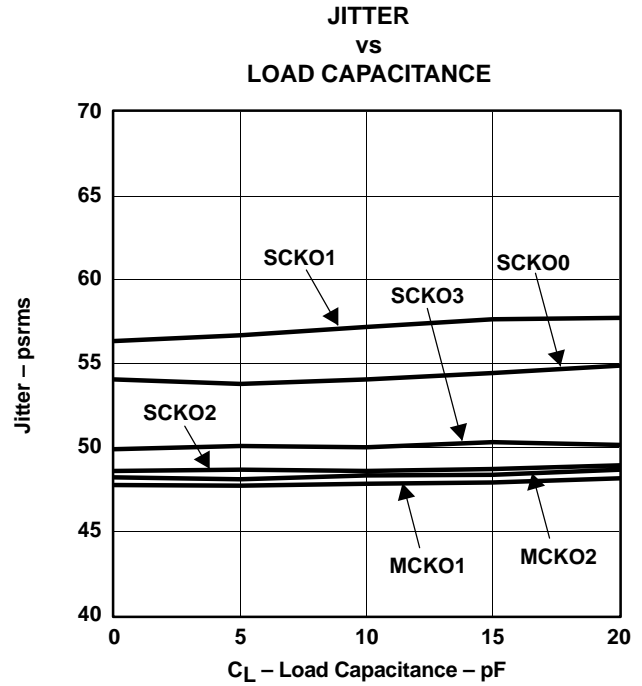

Figure 2

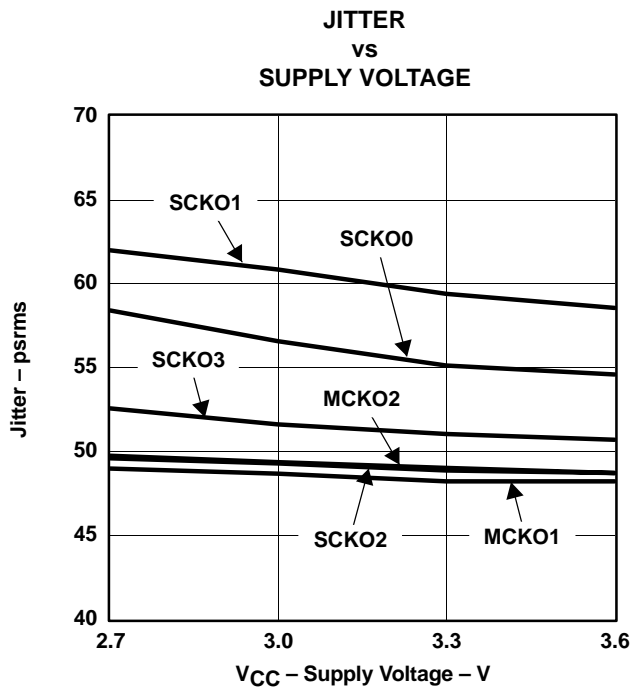

Figure 3

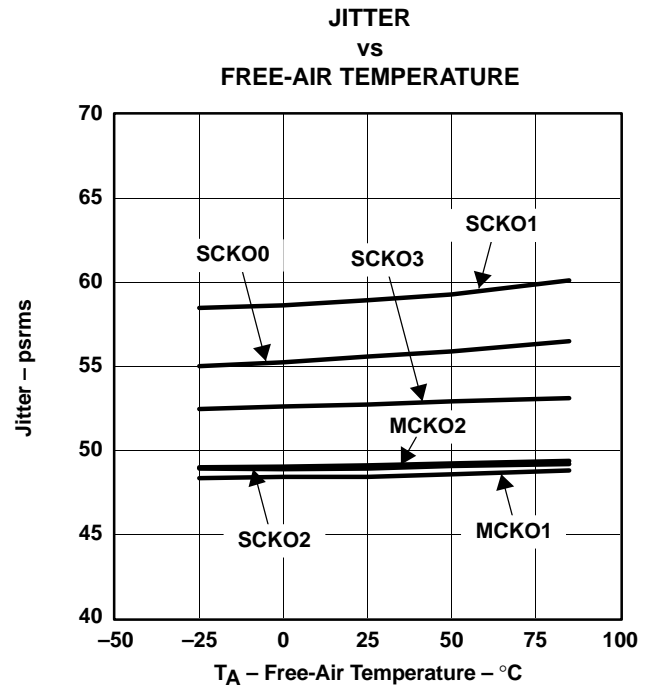

Figure 4

NOTE: All specifications at  $T_A = 25^\circ\text{C}$ ,  $V_{DD1-3} (= V_{DD}) = V_{CC} = +3.3\text{ V}$ ,  $f_M = 27\text{ MHz}$ , crystal oscillation,  $C_1, C_2 = 15\text{ pF}$ , default frequency (33.8688 MHz for SCKO0, 36.864 MHz for SCKO1, 256  $f_s$  and 384  $f_s$  of 48 kHz for SCKO2 and SCKO3),  $C_L = 20\text{ pF}$  on measurement pin, unless otherwise noted.

DUTY CYCLE  
VS  
SUPPLY VOLTAGE

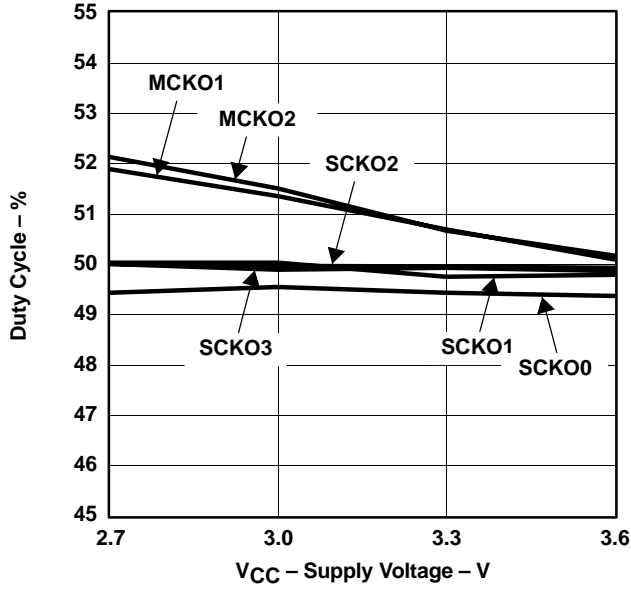

Figure 5

DUTY CYCLE  
VS  
FREE-AIR TEMPERATURE

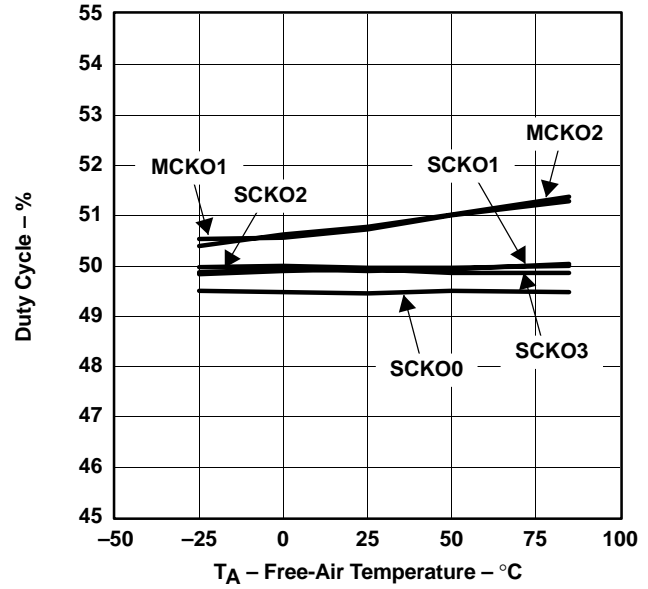

Figure 6

NOTE: All specifications at T<sub>A</sub> = 25°C, V<sub>DD1-3</sub> (= V<sub>DD</sub>) = V<sub>CC</sub> = +3.3 V, f<sub>M</sub> = 27 MHz, crystal oscillation, C<sub>1</sub>, C<sub>2</sub> = 15 pF, default frequency (33.8688 MHz for SCKO0, 36.864 MHz for SCKO1, 256 f<sub>S</sub> and 384 f<sub>S</sub> of 48 kHz for SCKO2 and SCKO3), C<sub>L</sub> = 20 pF on measurement pin, unless otherwise noted.

## THEORY OF OPERATION

### MASTER CLOCK AND SYSTEM CLOCK OUTPUT

The PLL1707/8 consists of a dual PLL clock and master clock generator which generates four system clocks and two buffered 27-MHz clocks from a 27-MHz master clock. Figure 7 shows the block diagram of the PLL1707/8. The PLL is designed to accept a 27-MHz master clock.

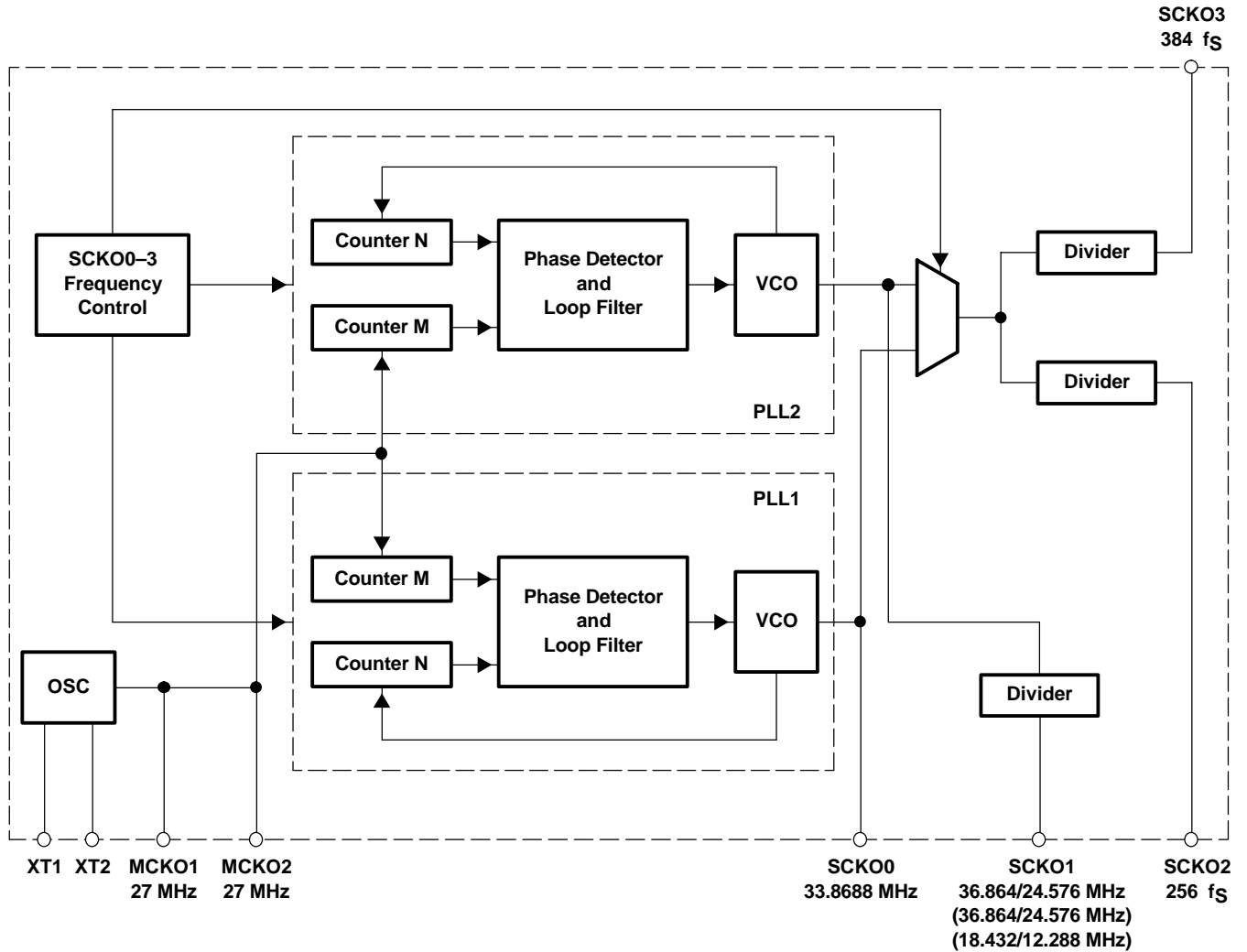

( ): PLL1708

Figure 7. Block Diagram



**Table 2. Sampling Frequencies**

SAMPLING RATE	SAMPLING FREQUENCY (kHz)		
Half sampling frequencies†	16	22.05	24
Standard sampling frequencies	32	44.1	48
Double sampling frequencies	64	88.2	96

† PLL1708 only

**Table 3. Sampling Frequencies and System Clock Output Frequencies**

SAMPLING FREQUENCY (kHz)	SAMPLING RATE	256 fs SCKO2 (MHZ)	384 fs SCKO3 (MHZ)
16†	Half	4.096	6.144
22.05†	Half	5.6448	8.4672
24†	Half	6.144	9.216
32	Standard	8.192	12.288
44.1	Standard	11.2896	16.9344
48	Standard	12.288	18.432
64	Double	16.384	24.576
88.2	Double	22.5792	33.8688
96	Double	24.576	36.864

† PLL1708 only

Response time from power on (or applying the clock to XT1) to SCKO settling time is typically 3 ms. Delay time from sampling frequency change to SCKO settling is 300 ns maximum. Figure 10 illustrates SCKO transient timing in the PLL1708.

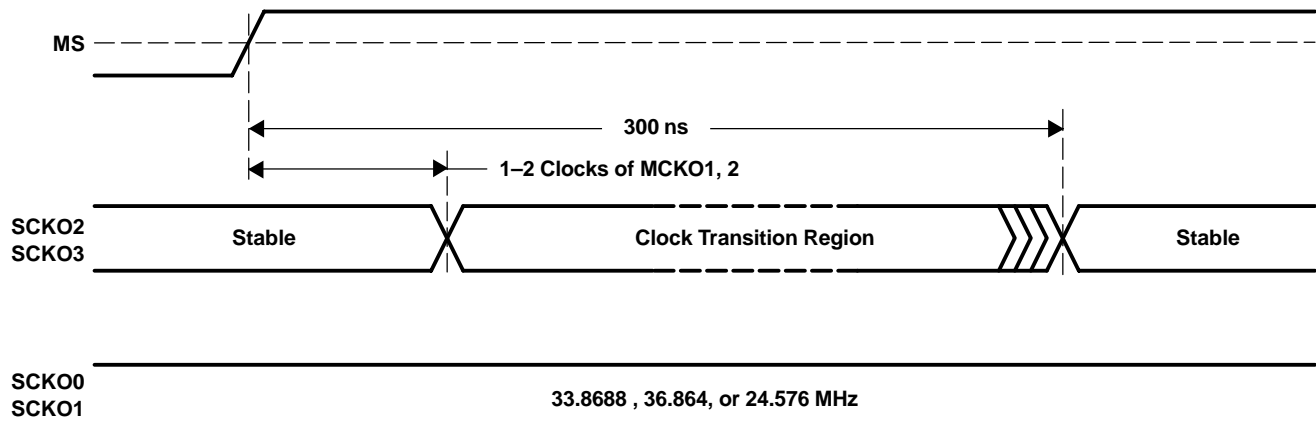

**Figure 10. System Clock Transient Timing**

The delay time for hardware control to use SR, FS2, FS1, or CSEL is 150 ns maximum. Figure 11 illustrates SCKO transient timing in the PLL1707. Clock transient timing is not synchronized with the SCKOs. External buffers are recommended on all output clocks in order to avoid degrading the jitter performance of the PLL1707/8.

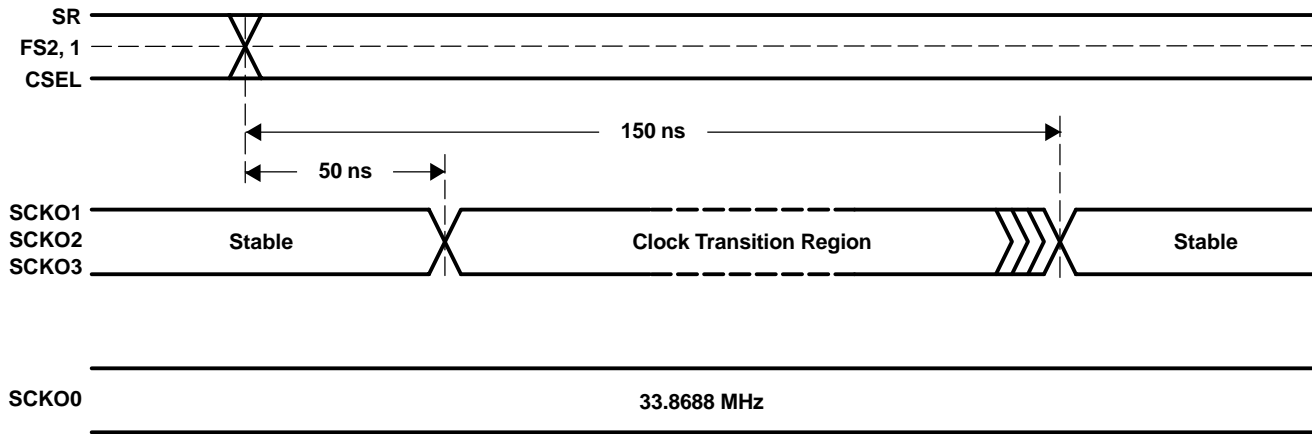

Figure 11. SCKO Transient Timing

### POWER-ON RESET

The PLL1707/8 has an internal power-on reset circuit. The mode register of the PLL1708 is initialized with default settings by power-on reset. Throughout the reset period, all clock outputs are enabled with the default settings after power-up time. Initialization by internal power-on reset is done automatically during 1024 master clocks at  $V_{DD} > 2.0$  V (TYP). Power-on reset timing is shown in Figure 12.

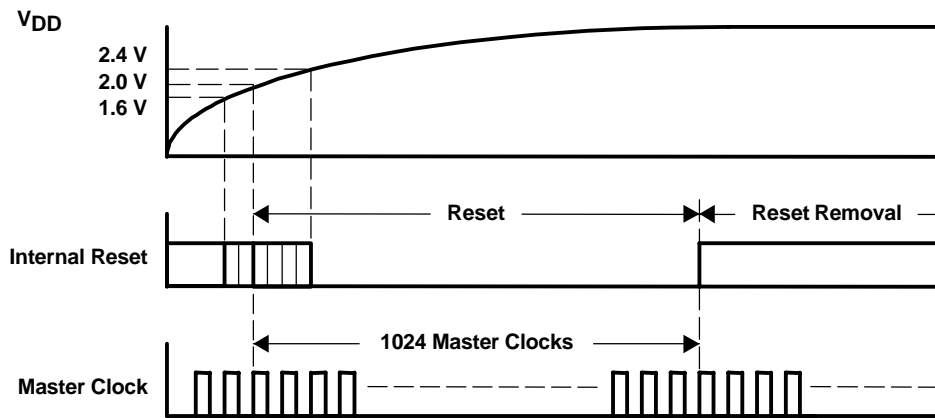

Figure 12. Power-On Reset Timing

## FUNCTION CONTROL

The built-in functions of the PLL1707 can be controlled in the parallel mode (hardware mode), which uses SR (pin 7), FS1 (pin 5) and FS2 (pin 6). The PLL1708 can be controlled in the serial mode (software mode), which has a three-wire interface using MS (pin 7), MC (pin 6), and MD (pin 5). The selectable functions are shown in Table 4.

**Table 4. Selectable Functions**

SELECTABLE FUNCTION	PARALLEL MODE	SERIAL MODE
Sampling frequency select (32 kHz, 44.1 kHz, 48 kHz)	Yes	Yes
Sampling rate select (standard/double)	Yes	Yes
Sampling rate select (half)	No	Yes
Each clock output enable/disable	No	Yes
Power down	No	Yes
SCKO1 configuration	No	Yes

### PLL1707 (Parallel Mode)

In the parallel mode, the following functions can be selected:

#### **Sampling Frequency Group Select**

The sampling frequency group can be selected by FS1 (pin 5) and FS2 (pin 6).

FS2 (PIN 6)	FS1 (PIN 5)	SAMPLING FREQUENCY
LOW	LOW	48 kHz
LOW	HIGH	44.1 kHz
HIGH	LOW	32 kHz
HIGH	HIGH	Reserved

#### **Sampling Rate Select**

The sampling rate can be selected by SR (pin 7)

SR (PIN 7)	SAMPLING RATE
LOW	Standard
HIGH	Double

#### **System Clock SCKO1 Frequency Select**

System clock SCKO1 frequency can be selected by CSEL (pin 12).

CSEL (PIN 12)	SCKO1 FREQUENCY
LOW	36.864 MHz
HIGH	24.576 MHz

### PLL1708 (Serial Mode)

The built-in functions of the PLL1708 are shown in Table 5. These functions are controlled using the MS, MC, and MD serial control signals.

**Table 5. Selectable Functions**

SELECTABLE FUNCTION	DEFAULT
Sampling frequency select (32 kHz, 44.1 kHz, 48 kHz)	48-kHz group
Sampling rate select (half, standard, double)	Standard
Each clock output enable/disable	Enabled
Power down	Disabled
SCKO1 configuration	36.864 MHz, 24.576 MHz

**Program-Register Bit Mapping**

The built-in functions of the PLL1708 are controlled through a 16-bit program register. This register is loaded using MD, MC and MS. After the 16 data bits are clocked in using the rising edge of MC, MS is used to latch the data into the register. Table 6 shows the bit mapping of the register. The serial mode control format and control data input timing are shown in Figure 13 and Figure 14, respectively.

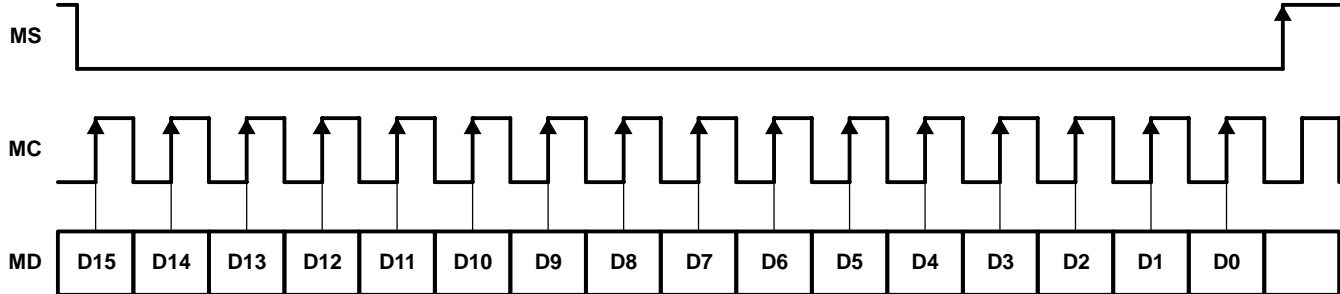

**Figure 13. Serial Mode Control Format**

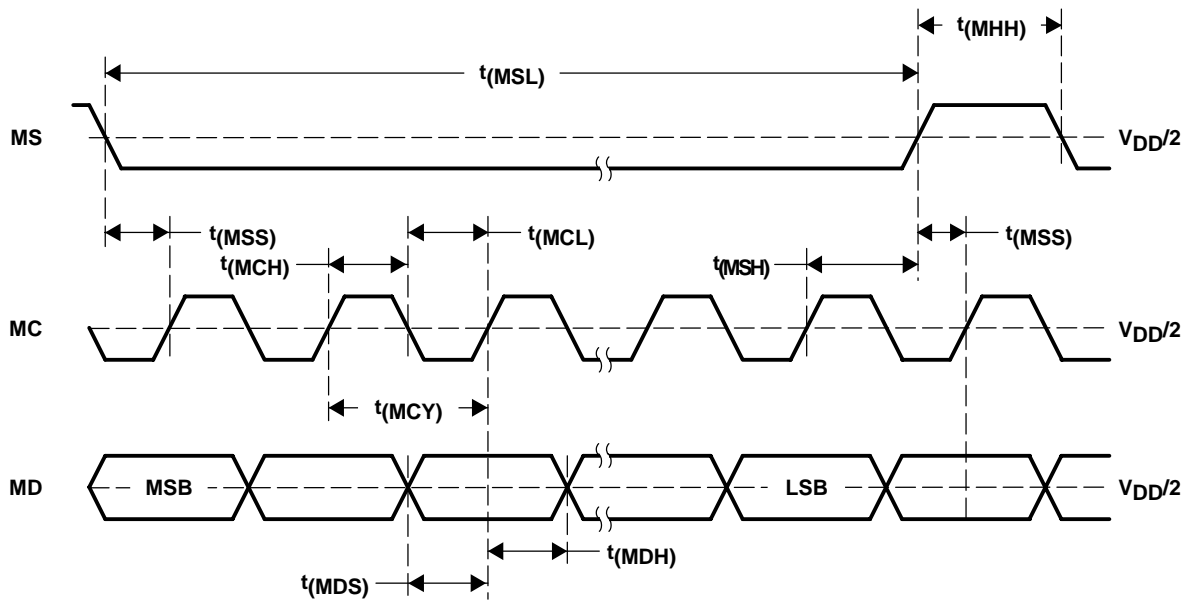

DESCRIPTION	SYMBOL	MIN	TYP	MAX	UNIT
MC pulse cycle time	t(MCY)	100			ns
MC pulse duration LOW	t(MCL)	40			ns
MC pulse duration HIGH	t(MCH)	40			ns
MD hold time	t(MDH)	40			ns
MD setup time	t(MDS)	40			ns
MS low-level time	t(MSL)	16			MC clocks <sup>(1)</sup>
MS high-level time	t(MHH)	200			ns
MS hold time <sup>(2)</sup>	t(MSH)	40			ns
MS setup time <sup>(3)</sup>	t(MSS)	40			ns

(1) MC clocks: MC clock period

(2) MC rising edge for LSB to MS rising edge

(3) MS rising edge to the next MC rising edge. If the MC clock is stopped after the LSB, any MS rise time is accepted.

**Figure 14. Control Data Input Timing**

## Mode Register

D15	D14	D13	D12	D11	D10	D9	D8	D7	D6	D5	D4	D3	D2	D1	D0
0	1	1	1	0	0	CE6	CE5	CE4	CE3	CE2	CE1	SR2	SR1	FS2	FS1

**Table 6. Mode Register Mapping**

REGISTER	BIT NAME	DESCRIPTION
Mode control	CE6	MCKO2 output enable/disable
	CE5	MCKO1 output enable/disable
	CE4	SCKO1 output enable/disable
	CE3	SCKO3 output enable/disable
	CE2	SCKO2 output enable/disable
	CE1	SCKO0 output enable/disable
	SR[2:1]	Sampling rate select
	FS[2:1]	Sampling frequency select

FS[2:1]: Sampling Frequency Group Select

FS2	FS1	SAMPLING FREQUENCY
0	0	48 kHz (default)
0	1	44.1 kHz
1	0	32 kHz
1	1	Reserved

SR[2:1]: Sampling Rate Select

SR2	SR1	SAMPLING RATE
0	0	Standard (default)
0	1	Double
1	0	Half
1	1	Reserved

CE [6:1]: Clock Output Control

CE1–CE6	CLOCK OUTPUT CONTROL
0	Clock output disable
1	Clock output enable (default)

While all the bits of CE [6:1] are 0, the PLL1708 goes into the power-down mode, all dynamic operation including PLLs and the oscillator halts, but serial mode control is enabled for resumption.

**Configuration Register**

D15	D14	D13	D12	D11	D10	D9	D8	D7	D6	D5	D4	D3	D2	D1	D0
0	1	1	0	1	1	RSV	RSV	RSV	RSV	RSV	CFG1	RSV	RSV	RSV	RSV

**Table 7. Configuration Register Mapping**

REGISTER	BIT NAME	DESCRIPTION
Configuration	RSV	Reserved, must be 0
	CFG1	SCKO1 configuration

CFG1: SCKO1 Configuration Control

CFG1	CONFIGURATION 1
0	36.864 MHz, 24.576 MHz for SCKO1 (default)
1	18.432 MHz, 12.288 MHz for SCKO1

The system clock SCKO1 frequency can be selected by CSEL (pin 12) and CFG1 (register).

CFG1 (REGISTER)	CSEL (PIN 12)	SCKO1
0	LOW	36.864 MHz
0	HIGH	24.576 MHz
1	LOW	18.432 MHz
1	HIGH	12.288 MHz

**CONNECTION DIAGRAM**

Figure 15 shows the typical connection circuit for the PLL1707. There are four grounds for digital and analog power supplies. However, the use of one common ground connection is recommended to avoid latch-up or other power-supply-related troubles. Power supplies should be bypassed as close as possible to the device.

**MPEG-2 APPLICATIONS**

Typical applications for the PLL1707/8 are MPEG-2 based systems such as DVD recorders, HDD recorders, DVD players, DVD add-on cards for multimedia PCs, digital HDTV systems, and set-top boxes. The PLL1707/8 provides audio system clocks for a CD-DA DSP, DVD DSP, Karaoke DSP, ADC(s), and DAC(s) from a 27-MHz video clock.

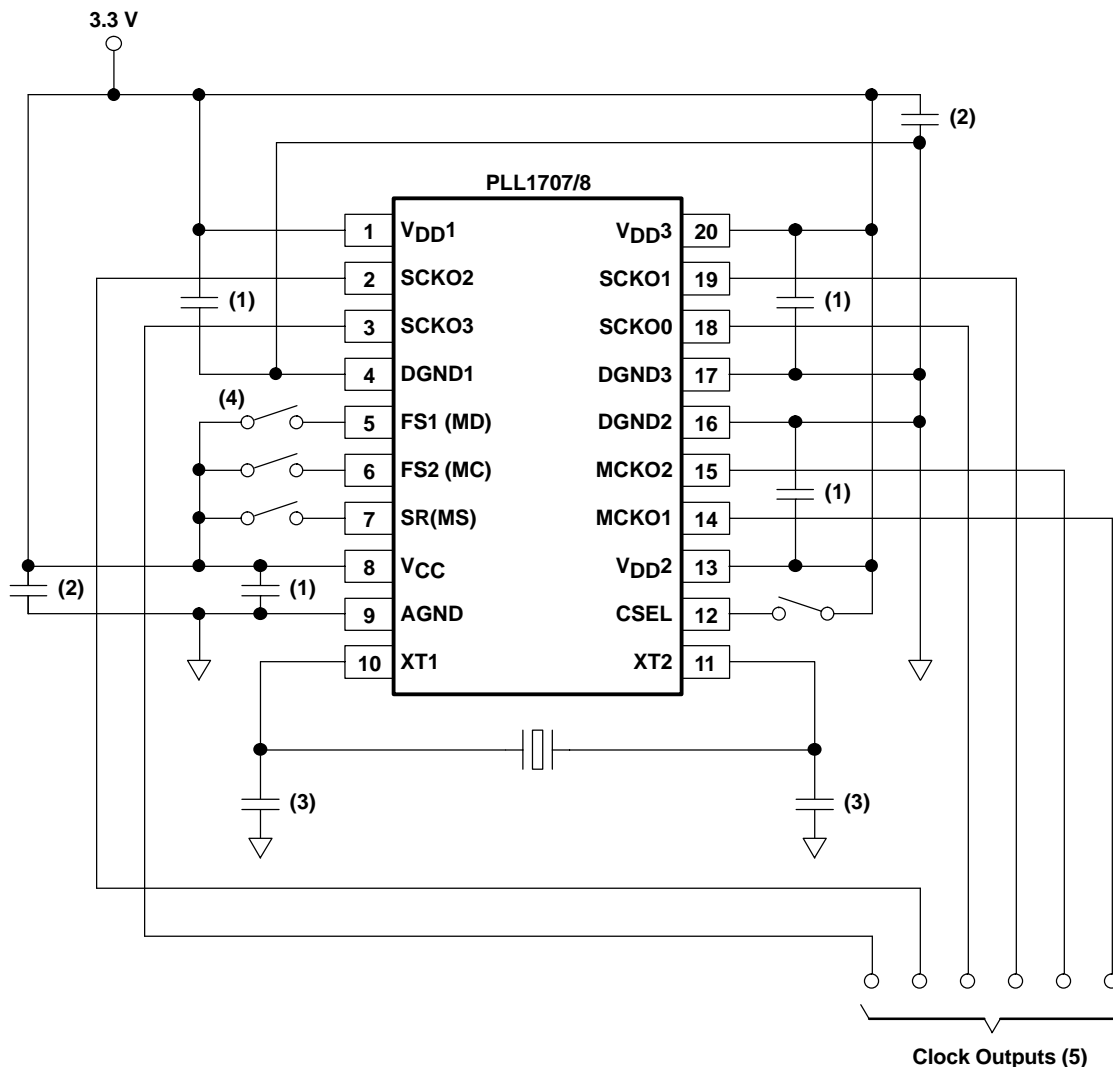

- (1) 0.1- $\mu$ F ceramic capacitor typical, depending on quality of power supply and pattern layout
- (2) 10- $\mu$ F aluminum electrolytic capacitor typical, depending on quality of power supply and pattern layout
- (3) 27-MHz quartz crystal and 10–33 pF  $\times$  2 ceramic capacitors, which generate the appropriate amplitude of oscillation on XT1/XT2
- (4) This connection is for PLL1707 (parallel mode); when PLL1708 (serial mode) is to be used, control pins must be connected to serial interfaced controller.
- (5) For good jitter performance, minimize the load capacitance on the clock output. It is recommended to drive the clock outputs through buffers, especially if there are heavy loads on SCKO0 and SCKO1, and to minimize mutual interference by separating them or inserting a guard pattern between them.

**Figure 15. Typical Connection Diagram**

**BLOCK DIAGRAM OF DVD PLAYER APPLICATION**

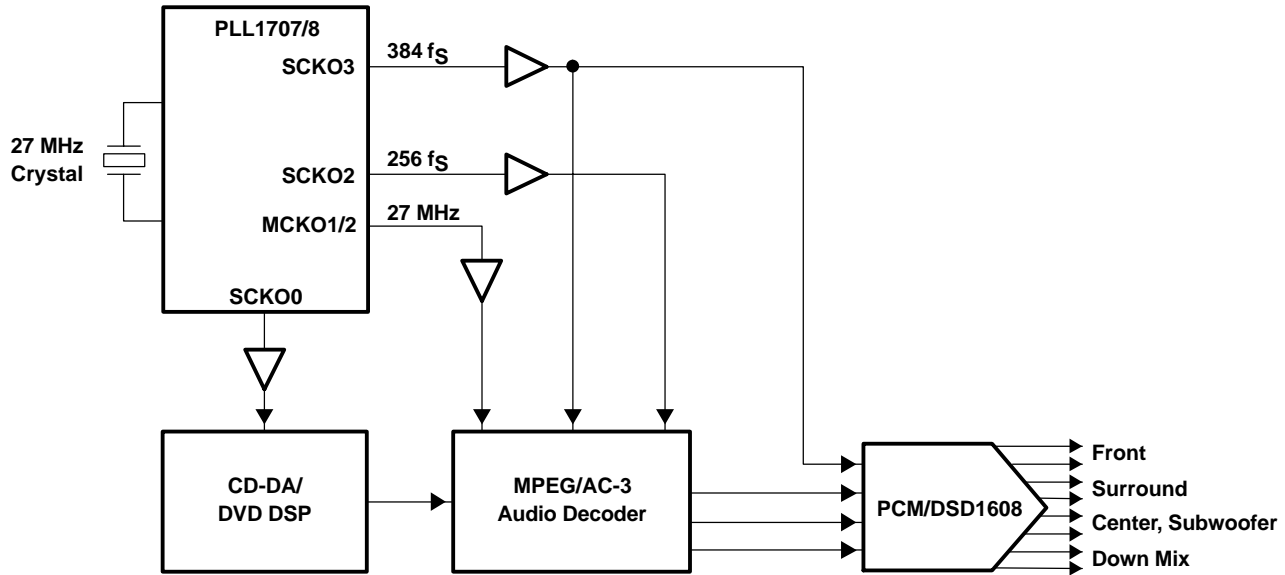

**BLOCK DIAGRAM OF HDD+DVD RECORDER APPLICATION**

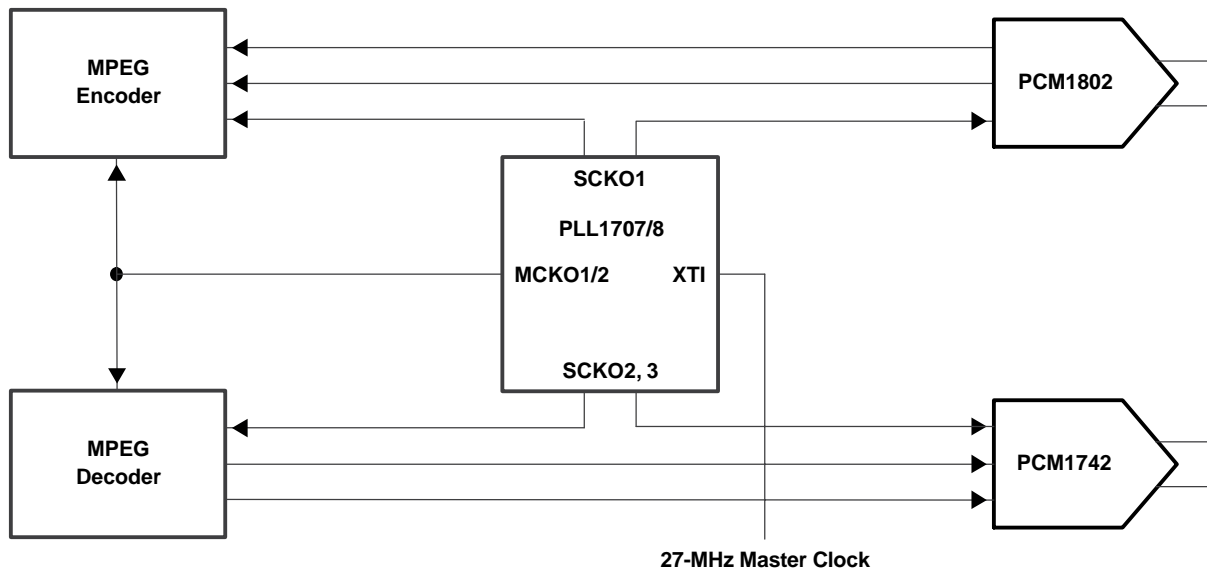

**PACKAGING INFORMATION**

Orderable Device	Status (1)	Package Type	Package Drawing	Pins	Package Qty	Eco Plan (2)	Lead/Ball Finish (6)	MSL Peak Temp (3)	Op Temp (°C)	Device Marking (4/5)	Samples
PLL1707DBQ	ACTIVE	SSOP	DBQ	20	50	Green (RoHS & no Sb/Br)	CU NIPDAU	Level-1-260C-UNLIM	-25 to 85	PLL1707	<a href="#">Samples</a>
PLL1707DBQR	ACTIVE	SSOP	DBQ	20	2000	Green (RoHS & no Sb/Br)	CU NIPDAU	Level-1-260C-UNLIM	-25 to 85	PLL1707	<a href="#">Samples</a>
PLL1708DBQ	ACTIVE	SSOP	DBQ	20	50	Green (RoHS & no Sb/Br)	CU NIPDAU	Level-1-260C-UNLIM	-25 to 85	PLL1708	<a href="#">Samples</a>
PLL1708DBQR	ACTIVE	SSOP	DBQ	20	2000	Green (RoHS & no Sb/Br)	CU NIPDAU	Level-1-260C-UNLIM	-25 to 85	PLL1708	<a href="#">Samples</a>
PLL1708DBQRG4	ACTIVE	SSOP	DBQ	20	2000	Green (RoHS & no Sb/Br)	CU NIPDAU	Level-1-260C-UNLIM	-25 to 85	PLL1708	<a href="#">Samples</a>

(1) The marketing status values are defined as follows:

**ACTIVE:** Product device recommended for new designs.

**LIFEBUY:** TI has announced that the device will be discontinued, and a lifetime-buy period is in effect.

**NRND:** Not recommended for new designs. Device is in production to support existing customers, but TI does not recommend using this part in a new design.

**PREVIEW:** Device has been announced but is not in production. Samples may or may not be available.

**OBSOLETE:** TI has discontinued the production of the device.

(2) **RoHS:** TI defines "RoHS" to mean semiconductor products that are compliant with the current EU RoHS requirements for all 10 RoHS substances, including the requirement that RoHS substance do not exceed 0.1% by weight in homogeneous materials. Where designed to be soldered at high temperatures, "RoHS" products are suitable for use in specified lead-free processes. TI may reference these types of products as "Pb-Free".

**RoHS Exempt:** TI defines "RoHS Exempt" to mean products that contain lead but are compliant with EU RoHS pursuant to a specific EU RoHS exemption.

**Green:** TI defines "Green" to mean the content of Chlorine (Cl) and Bromine (Br) based flame retardants meet JS709B low halogen requirements of <=1000ppm threshold. Antimony trioxide based flame retardants must also meet the <=1000ppm threshold requirement.

(3) MSL, Peak Temp. - The Moisture Sensitivity Level rating according to the JEDEC industry standard classifications, and peak solder temperature.

(4) There may be additional marking, which relates to the logo, the lot trace code information, or the environmental category on the device.

(5) Multiple Device Markings will be inside parentheses. Only one Device Marking contained in parentheses and separated by a "-" will appear on a device. If a line is indented then it is a continuation of the previous line and the two combined represent the entire Device Marking for that device.

(6) Lead/Ball Finish - Orderable Devices may have multiple material finish options. Finish options are separated by a vertical ruled line. Lead/Ball Finish values may wrap to two lines if the finish value exceeds the maximum column width.

**Important Information and Disclaimer:** The information provided on this page represents TI's knowledge and belief as of the date that it is provided. TI bases its knowledge and belief on information provided by third parties, and makes no representation or warranty as to the accuracy of such information. Efforts are underway to better integrate information from third parties. TI has taken and continues to take reasonable steps to provide representative and accurate information but may not have conducted destructive testing or chemical analysis on incoming materials and chemicals. TI and TI suppliers consider certain information to be proprietary, and thus CAS numbers and other limited information may not be available for release.

In no event shall TI's liability arising out of such information exceed the total purchase price of the TI part(s) at issue in this document sold by TI to Customer on an annual basis.

**OTHER QUALIFIED VERSIONS OF PLL1707 :**

- Automotive: [PLL1707-Q1](#)

NOTE: Qualified Version Definitions:

- Automotive - Q100 devices qualified for high-reliability automotive applications targeting zero defects

**TAPE AND REEL INFORMATION**

**REEL DIMENSIONS**

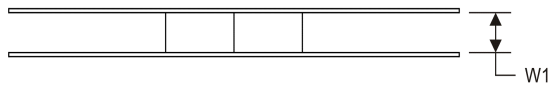
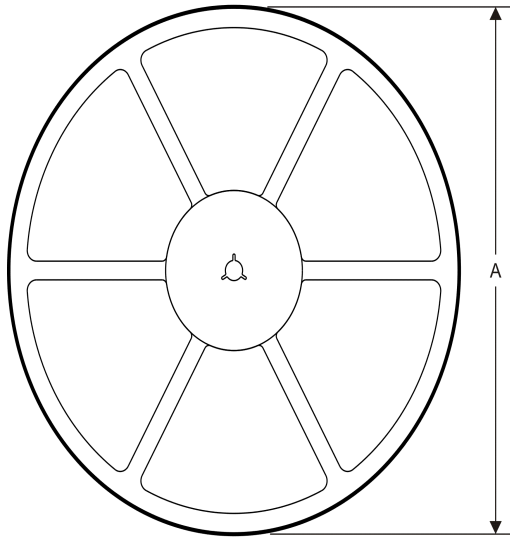

**TAPE DIMENSIONS**

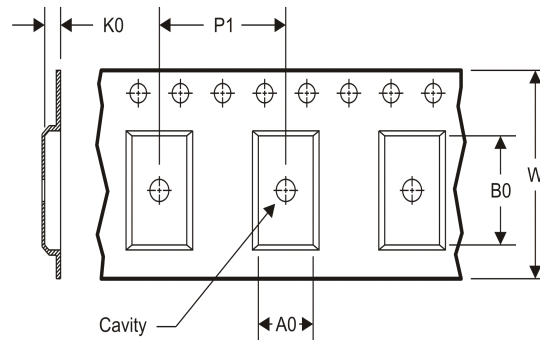

A0	Dimension designed to accommodate the component width
B0	Dimension designed to accommodate the component length
K0	Dimension designed to accommodate the component thickness
W	Overall width of the carrier tape
P1	Pitch between successive cavity centers

**TAPE AND REEL INFORMATION**

\*All dimensions are nominal

Device	Package Type	Package Drawing	Pins	SPQ	Reel Diameter (mm)	Reel Width W1 (mm)	A0 (mm)	B0 (mm)	K0 (mm)	P1 (mm)	W (mm)	Pin1 Quadrant
PLL1707DBQR	SSOP	DBQ	20	2000	330.0	16.4	6.5	9.0	2.1	8.0	16.0	Q1
PLL1708DBQR	SSOP	DBQ	20	2000	330.0	16.4	6.5	9.0	2.1	8.0	16.0	Q1

**TAPE AND REEL BOX DIMENSIONS**



\*All dimensions are nominal

Device	Package Type	Package Drawing	Pins	SPQ	Length (mm)	Width (mm)	Height (mm)
PLL1707DBQR	SSOP	DBQ	20	2000	367.0	367.0	38.0
PLL1708DBQR	SSOP	DBQ	20	2000	367.0	367.0	38.0

DBQ (R-PDSO-G20)

PLASTIC SMALL-OUTLINE PACKAGE

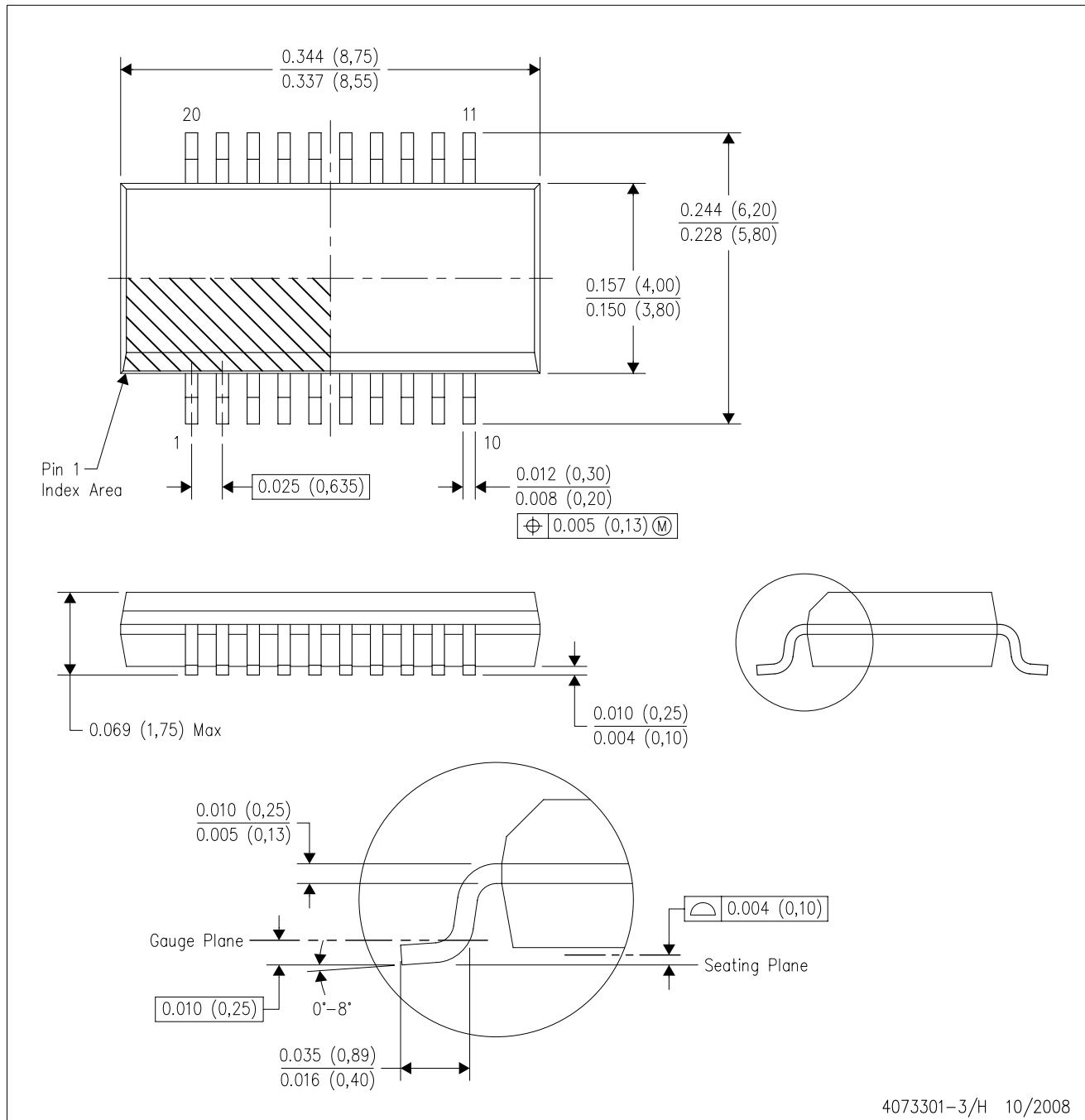

- NOTES:
- A. All linear dimensions are in inches (millimeters).
  - B. This drawing is subject to change without notice.
  - C. Body dimensions do not include mold flash or protrusion not to exceed 0.006 (0,15) per side.
  - D. Falls within JEDEC MO-137 variation AD.

DBQ (R-PDSO-G20)

PLASTIC SMALL OUTLINE PACKAGE

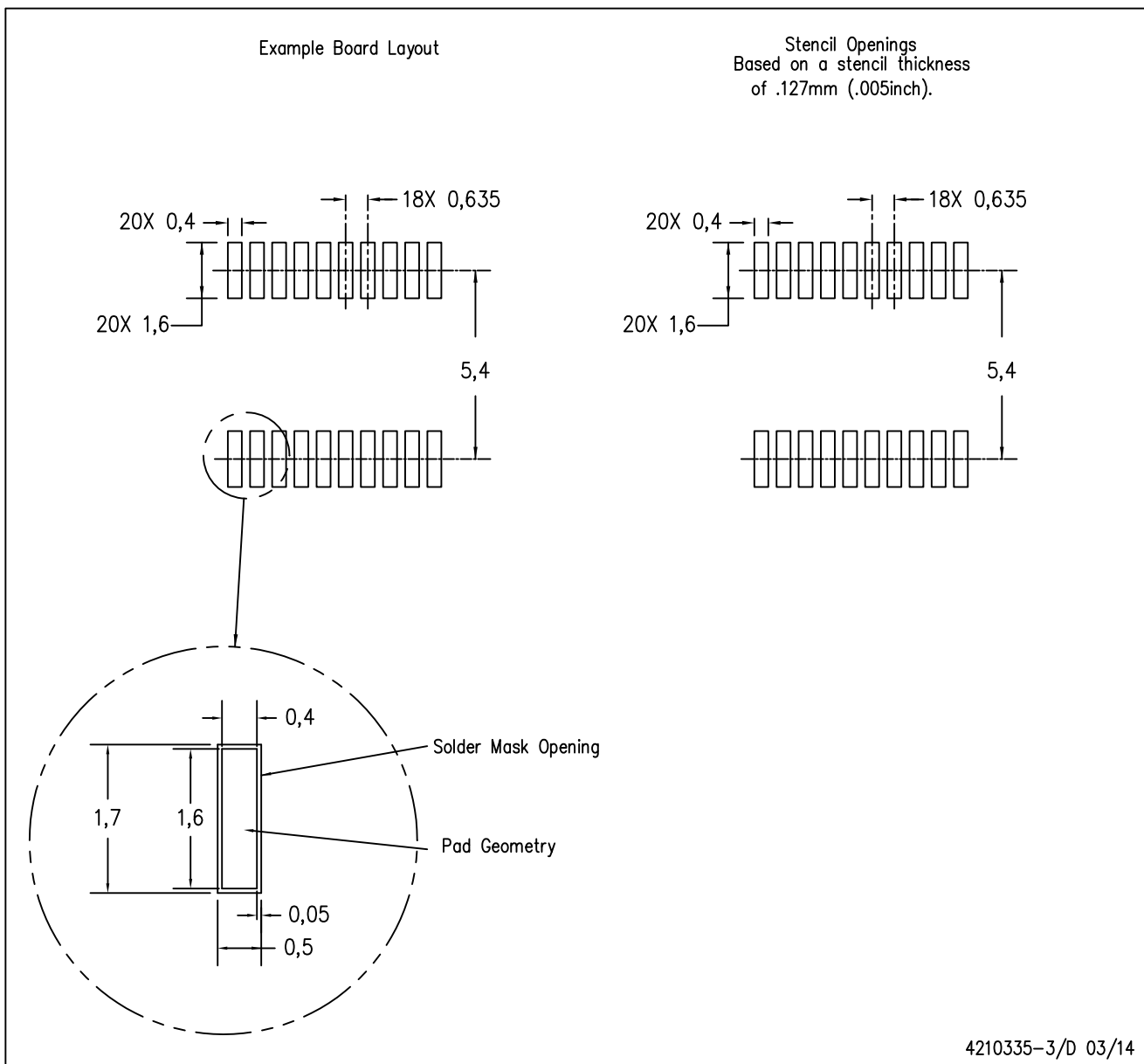

- NOTES:
- A. All linear dimensions are in millimeters.
  - B. This drawing is subject to change without notice.
  - C. Publication IPC-7351 is recommended for alternate designs.
  - D. Laser cutting apertures with trapezoidal walls and also rounding corners will offer better paste release. Customers should contact their board assembly site for stencil design recommendations. Example stencil design based on a 50% volumetric metal load solder paste. Refer to IPC-7525 for other stencil recommendations.

## IMPORTANT NOTICE AND DISCLAIMER

TI PROVIDES TECHNICAL AND RELIABILITY DATA (INCLUDING DATASHEETS), DESIGN RESOURCES (INCLUDING REFERENCE DESIGNS), APPLICATION OR OTHER DESIGN ADVICE, WEB TOOLS, SAFETY INFORMATION, AND OTHER RESOURCES "AS IS" AND WITH ALL FAULTS, AND DISCLAIMS ALL WARRANTIES, EXPRESS AND IMPLIED, INCLUDING WITHOUT LIMITATION ANY IMPLIED WARRANTIES OF MERCHANTABILITY, FITNESS FOR A PARTICULAR PURPOSE OR NON-INFRINGEMENT OF THIRD PARTY INTELLECTUAL PROPERTY RIGHTS.

These resources are intended for skilled developers designing with TI products. You are solely responsible for (1) selecting the appropriate TI products for your application, (2) designing, validating and testing your application, and (3) ensuring your application meets applicable standards, and any other safety, security, or other requirements. These resources are subject to change without notice. TI grants you permission to use these resources only for development of an application that uses the TI products described in the resource. Other reproduction and display of these resources is prohibited. No license is granted to any other TI intellectual property right or to any third party intellectual property right. TI disclaims responsibility for, and you will fully indemnify TI and its representatives against, any claims, damages, costs, losses, and liabilities arising out of your use of these resources.

TI's products are provided subject to TI's Terms of Sale ([www.ti.com/legal/termsofsale.html](http://www.ti.com/legal/termsofsale.html)) or other applicable terms available either on [ti.com](http://ti.com) or provided in conjunction with such TI products. TI's provision of these resources does not expand or otherwise alter TI's applicable warranties or warranty disclaimers for TI products.

Mailing Address: Texas Instruments, Post Office Box 655303, Dallas, Texas 75265  
Copyright © 2019, Texas Instruments Incorporated

## Looking for pricing, stock, or lifecycle information?

Click below to explore more details on WIN SOURCE:

 [View PLL1708DBQ](#) on WIN SOURCE

 [Texas Instruments](#) Information

## Optimize Your Supply Chain with WIN SOURCE Solutions

-  Global Sourcing Solution
-  Obsolete Management
-  Cost Control Management
-  Shortage Management
-  Alternative Solution
-  Excess Inventory Management