

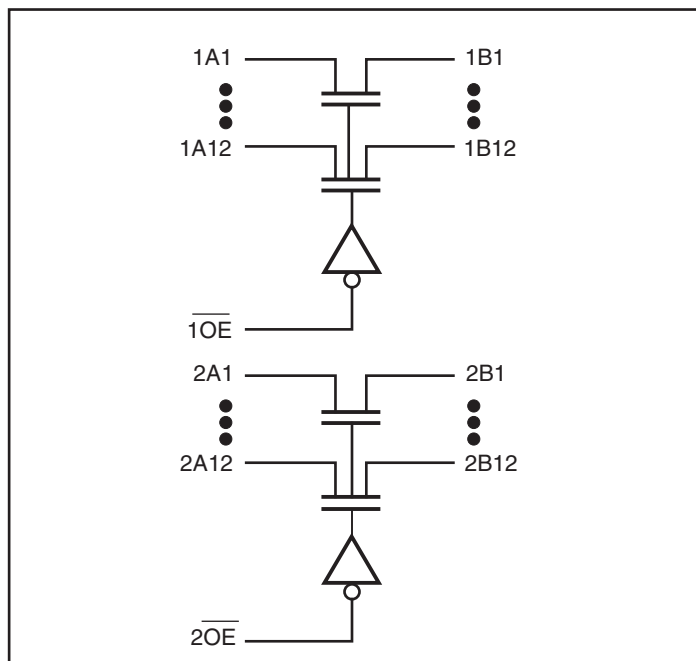

**Features**

- Near-Zero propagation delay
- 5Ω switch connects inputs to outputs
- Direct bus connection when switches are ON
- Ultra-low quiescent power (0.2 μA typical)  
– Ideally suited for notebook applications
- Industrial operating temperature: -40°C to +85°C
- Packaging (Pb-free & Green available):  
– 56-pin 173-mil wide plastic TVSOP  
– 56-pin 240-mil wide thin plastic TSSOP  
– 56-pin 300-mil wide plastic SSOP

**Block Diagram**

**Truth Table**

$\overline{1OE}$	$\overline{2OE}$	1A, 1B, I/Os	2A, 2B, I/Os
L	L	$1A = 1B$	$2A = 2B$
L	H	$1A = 1B$	Z
H	L	Z	$2A = 2B$
H	H	Z	Z

**Note:**

1. H = High Voltage Level, L = Low Voltage Level, Z = High Impedance

**Description**

Pericom Semiconductor's PI5C16211 is a 24-bit bus switch designed with a low On-Resistance allowing inputs to be connected directly to outputs. This device operates as a 24-bit or a 12-bit bus switch, which provides high speed bus switching.

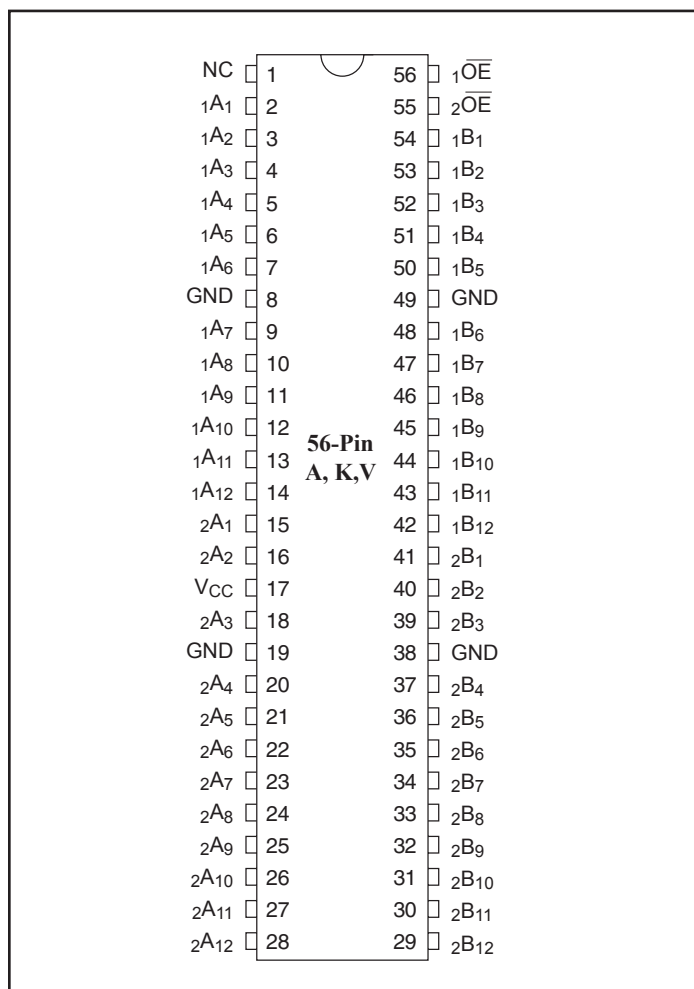
**Pin Configuration**

**Pin Description**

Pin Name	I/O	Description
$\overline{xOE}$	I	Output Enables
$xAx$	I/O	Bus A
$xBx$	I/O	Bus B

### Maximum Ratings

(Above which the useful life may be impaired. For user guidelines, not tested.)

Storage Temperature .....	-65°C to +150°C
Ambient Temperature with Power Applied .....	-40°C to +85°C
Supply Voltage to Ground Potential (Inputs & V <sub>CC</sub> Only).....	-0.5V to +7.0V
Supply Voltage to Ground Potential (Outputs & D/O Only) .....	-0.5V to +7.0V
DC Input Voltage .....	-0.5V to +7.0V
DC Output Current.....	120mA
Power Dissipation .....	1.4W

**Note:**

Stresses greater than those listed under MAXIMUM RATINGS may cause permanent damage to the device. This is a stress rating only and functional operation of the device at these or any other conditions above those indicated in the operational sections of this specification is not implied. Exposure to absolute maximum rating conditions for extended periods may affect reliability.

### DC Electrical Characteristics (Over the Operating Range, T<sub>A</sub> = -40°C to +85°C, V<sub>CC</sub> = 5V ±10%)

Parameters	Description	Test Conditions	Min.	Typ <sup>(1)</sup>	Max.	Units
V <sub>IK</sub>	Clamp Diode Voltage	V <sub>CC</sub> = 4.5V, I <sub>I</sub> = -18mA		—	1.2	V
I <sub>I</sub>	Input LOW Current	V <sub>CC</sub> = 5.5V, V <sub>I</sub> = V <sub>CC</sub> or GND	—	—	10	μA
		V <sub>CC</sub> = 0V, V <sub>I</sub> = 5.5V	—	—	±1	
I <sub>CC</sub>	Quiescent Power Supply Current	V <sub>CC</sub> = 5.5V, V <sub>I</sub> = V <sub>CC</sub> or GND	—	—	3.0	
ΔI <sub>CC</sub>	Supply Current per Control Input @ TTL High	V <sub>CC</sub> = 5.5V, One input at 3.4V, other inputs at V <sub>CC</sub> or GND	—	—	2.5	mA
C <sub>I</sub> <sup>(2)</sup>	Control Input Capacitance	V <sub>I</sub> = 3V or 0		—	4.5	pF
C <sub>IO(OFF)</sub> <sup>(2)</sup>	A/B Switch OFF Capacitance	V <sub>O</sub> = 3V or 0, OE = V <sub>CC</sub>		—	5.5	
R <sub>ON</sub>	Switch On Resistance <sup>(3)</sup>	V <sub>CC</sub> = 4.0V, V <sub>I</sub> = 2.4V, I <sub>I</sub> = 15 mA	—	14	20	Ω
		V <sub>CC</sub> = 4.5V, V <sub>I</sub> = 0V, I <sub>I</sub> = 64 mA	—	5	7	
		V <sub>CC</sub> = 4.5V, V <sub>I</sub> = 0V, I <sub>I</sub> = 30 mA	—	5	7	
		V <sub>CC</sub> = 4.5V, I <sub>I</sub> = 2.4V, I <sub>I</sub> = 15 mA	—	8	12	

**Notes:**

1. Typical values are at V<sub>CC</sub> = 5.0V, T<sub>A</sub> = 25°C ambient and maximum loading.
2. This parameter is determined by device characterization but is not production tested.
3. Measured by the voltage drop between A and B pin at indicated current through the switch. ON resistance is determined by the lower of the voltages on the two (A,B) pins.

**Power Supply Characteristics**

Parameters	Description	Min.	Typ.	Max.	Units
V <sub>CC</sub>	Supply Voltage	4.0		5.5	V
V <sub>IH</sub>	High Level Input Voltage	2.0			
V <sub>IL</sub>	Low Level Input voltage			0.8	
T <sub>A</sub>	Operating Free-Air Tempertaure	-40		85	°C

**Note:**

1. Typical values are at V<sub>CC</sub> = 5.0V, +25°C ambient.

**Switching Characteristics over Operating Range**

Parameters	From (Input)	To (Output)	Test Conditions	V <sub>CC</sub> = 5V ±0.5V		V <sub>CC</sub> = 4V		Units
				Min.	Max.	Min.	Max.	
t <sub>PD</sub> <sup>(1)</sup>	A or B	B or A	C <sub>L</sub> = 50pF R <sub>L</sub> = 500Ω		0.25		0.25	ns
t <sub>EN</sub>	OE	A or B		1.5	9.3		10.1	
t <sub>DIS</sub>	OE	A or B		1.5	8.5		7.1	

**Notes:**

1. This parameter is guaranteed but not tested on Propagation Delays. The bus switch contributes no propagational delay other than the RC delay of the ON resistance of the switch and the load capacitance. The time constant for the switch alone is of the order of 0.25ns for 50pF load. Since this time constant is much smaller than the rise/fall times of typical driving signals, it adds very little propagational delay to the system. Propagational delay of the bus switch when used in a system is determined by the driving circuit on the driving side of the switch and its interaction with the load on the driven side.

Packaging Mechanical: 56-pin TVSOP (K)

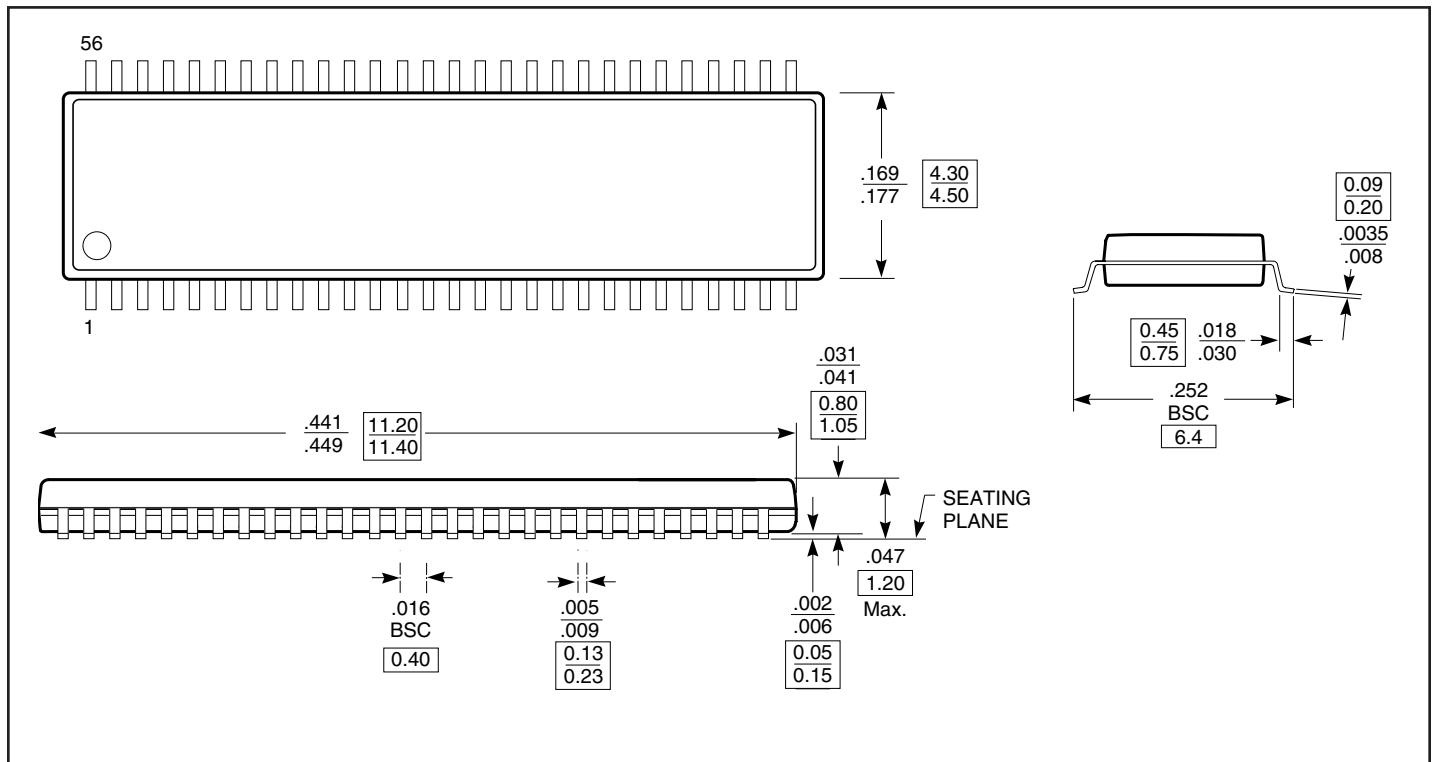

Packaging Mechanical: 56-pin TSSOP (A)

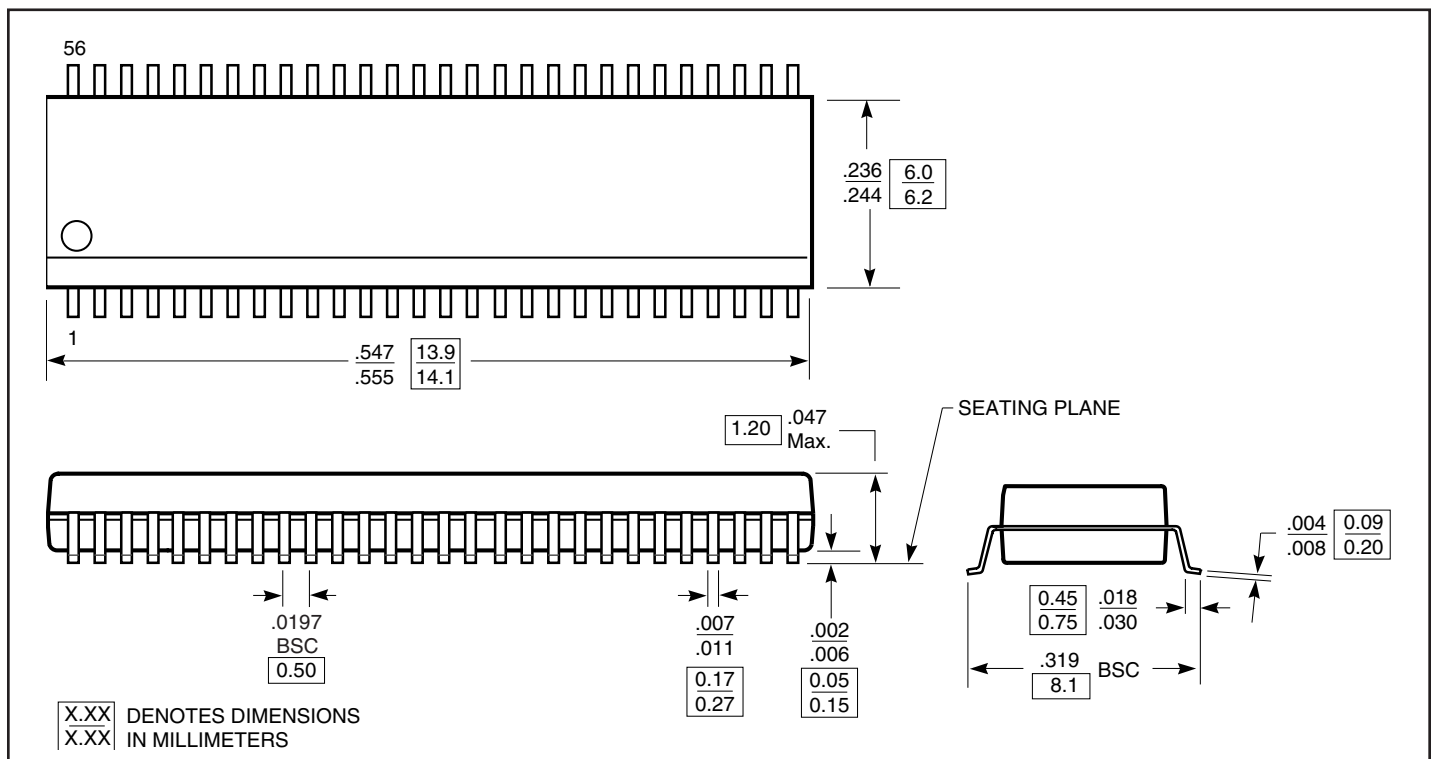

### Packaging Mechanical: 56-pin SSOP (V)

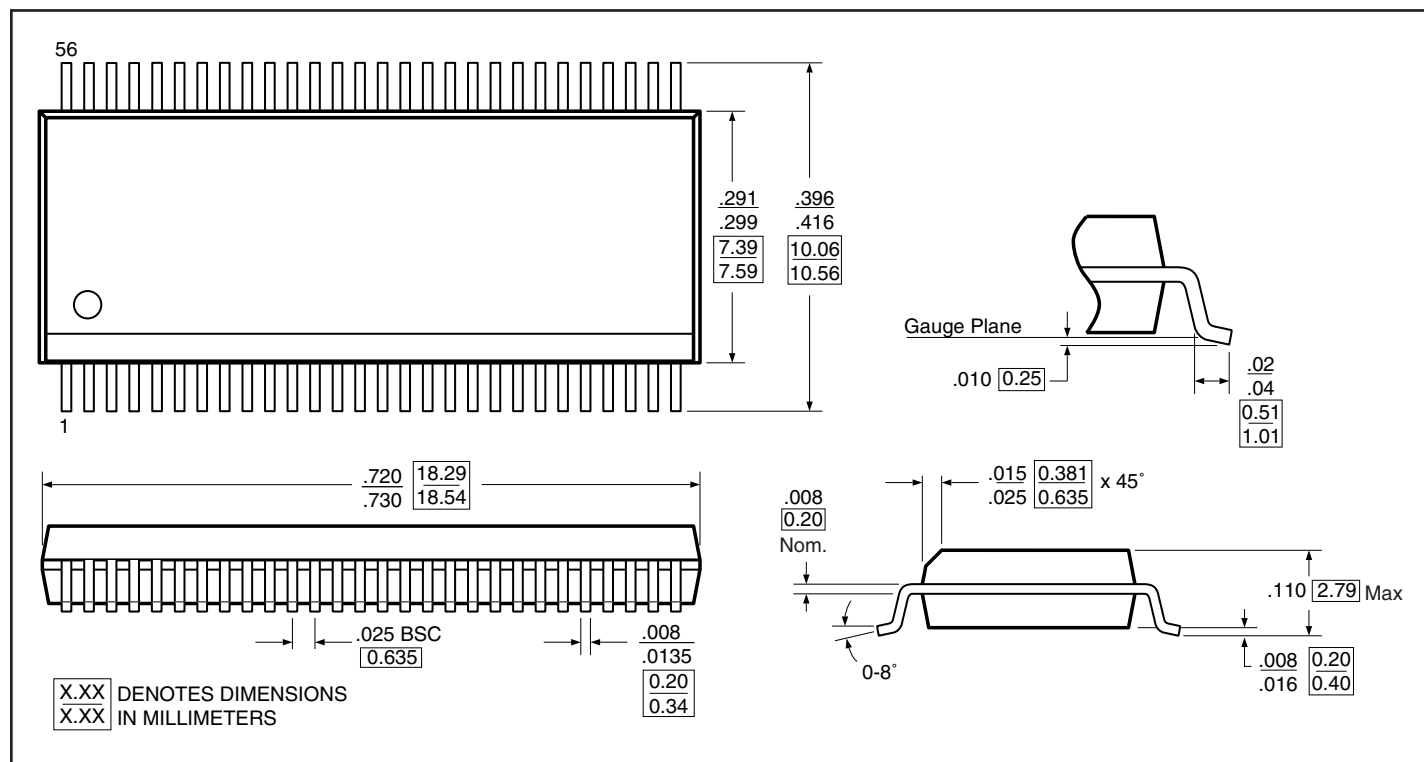

### Ordering Information

Ordering Code	Package Type	Package Description
PI5C16211A	A	56-pin 240-mil wide TSSOP
PI5C16211AE	A	Pb-free & Green, 56-pin 240-mil wide TSSOP
PI5C16211K	K	56-pin 173-mil wide TVSOP
PI5C16211KE	K	Pb-free & Green, 56-pin 173-mil wide TVSOP
PI5C16211V	V	56-pin 300-mil wide SSOP
PI5C16211VE	V	Pb-free & Green, 56-pin 300-mil wide SSOP

#### Notes:

1. Thermal characteristics can be found on the company web site at [www.pericom.com/packaging/](http://www.pericom.com/packaging/)
2. For Tape and Reel, include 'x' at the end of the part number.

## Looking for pricing, stock, or lifecycle information?

Click below to explore more details on WIN SOURCE:

 [View PI5C16211AEX on WIN SOURCE](#)

 [Diodes Incorporated Information](#)

## Optimize Your Supply Chain with WIN SOURCE Solutions

-  Global Sourcing Solution
-  Obsolete Management
-  Cost Control Management
-  Shortage Management
-  Alternative Solution
-  Excess Inventory Management