



**THE DATASHEET OF  
PI3A3160ZEEX**



### Features

- CMOS Technology for Bus and Analog Applications
- Low On-Resistance: 0.4Ω (+2.7V Supply)
- Wide V<sub>DD</sub> Range: +1.5V to +4.2V
- Low Power Consumption : 5μW
- Rail-to-Rail switching throughout Signal Range
- Fast Switching Speed: 20ns max. at 3.3V
- High Off Isolation: -27dB at 100 kHz
- -41dB (100 kHz) Crosstalk Rejection Reduces Signal Distortion
- Extended Industrial Temperature Range: -40°C to 85°C
- Packaging:
  - Pb-free & Green, 12-pin TDFN (ZE)

### Applications

- Cell Phones
- PDAs
- Portable Instrumentation
- Battery Powered Communications
- Computer Peripherals

### Pin Description

Pin Number	Name	Description
8, 11	NO <sub>x</sub>	Data Port (Normally Open)
3, 6	GND	Ground
2, 5	NC <sub>x</sub>	Data Port (Normally Closed)
1, 4	COM <sub>x</sub>	Common Output/Data Port
9, 12	V <sub>DDx</sub>	Postive Power Supply <sup>(2)</sup>
7, 10	IN <sub>x</sub>	Logic Control

#### Notes:

1. x = 0 or 1
2. V<sub>DD0</sub> ad V<sub>DD1</sub> are not internally connected. Each must be powered seperately.

### Description

The PI3A3160 is a fast Dual single-pole double-throw (SPDT) CMOS switch. It can be used as an analog switch or as a low-delay bus switch. Specified over a wide operating power supply voltage range, +1.5V to +4.2V, the switch has an On-Resistance of 0.4Ω at 3.0V.

Control inputs, IN, tolerates input drive signals up to 3.3V, independent of supply voltage.

PI3A3160 is a lower voltage and On-Resistance replacement for the PI5A3158.

### Block Diagram / Pin Configuration

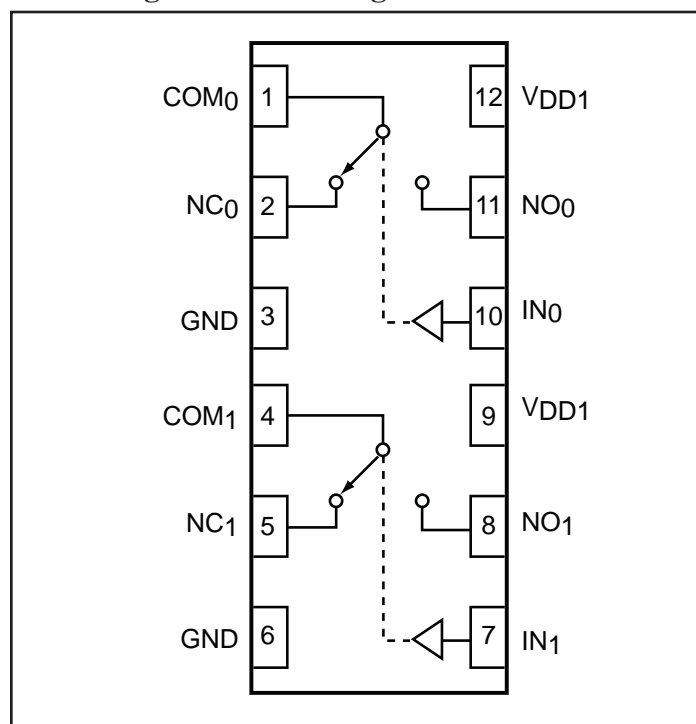

### Function Table

Logic Input	Function
0	NC <sub>x</sub> Connected to COM <sub>x</sub>
1	NO <sub>x</sub> Connected to COM <sub>x</sub>

### Absolute Maximum Ratings

Voltages Referenced to GND

$V_{DD}$  ..... -0.5V to +4.4V

$V_{IN}$ ,  $V_{COM}$ ,  $V_{NC}$ ,  $V_{NO}$  <sup>(1)</sup> ..... -0.5V to  $V_{+}$  +0.3V  
or 30mA, whichever occurs first

Current (any terminal)..... ±200mA

Peak Current, COM, NO, NC

(Pulsed at 1ms, 10% duty cycle)..... ±400mA

### Thermal Information

Continuous Power Dissipation

SOT23 (derate 7.1mW/°C above +70°C)..... 0.5W

Storage Temperature ..... -65°C to +150°C

Lead Temperature (soldering, 10s) ..... +300°C

**Note 1:** Signals on NC, NO, COM, or IN exceeding  $V_{DD}$  or GND are clamped by internal diodes. Limit forward diode current to 30mA.

**Caution:** Stresses beyond those listed under “Absolute Maximum Ratings” may cause permanent damage to the device. This is a stress only rating and operation of the device at these or any other conditions beyond those indicated in the operational sections of this specification is not implied.

### Electrical Specifications - Single +4.2V Supply

( $V_{DD} = +4.2V \pm 5\%$ ,  $GND = 0V$ ,  $V_{IH} = 1.6V$ ,  $V_{IL} = 0.7V$ )

Parameter	Symbol	Conditions	Temp. (°C)	Min. <sup>(1)</sup>	Typ. <sup>(2)</sup>	Max. <sup>(1)</sup>	Units		
<b>Analog Switch</b>									
Analog Signal Range <sup>(3)</sup>	$V_{ANALOG}$		Full	0		$V_{DD}$	V		
On Resistance	$R_{ON}$	$V_{DD} = 4.0V$ , $I_{COM} = 99mA$ , $V_{IN} = 0V$ to $V_{DD}$	25		0.4	0.45	Ω		
			Full			0.6			
On-Resistance Match Between Channels <sup>(4)</sup>	$\Delta R_{ON}$		25			0.08			
			Full			0.09			
On-Resistance Flatness <sup>(5)</sup>	$R_{FLAT(ON)}$	$V_{DD} = 4.0V$ , $I_{COM} = 100mA$	25			0.1	Ω		
			Full			0.1			
NO or NC Off Leakage Current <sup>(6)</sup>	$I_{NO(OFF)}$ or $I_{NC(OFF)}$		$V_{DD} = 4.2V$	25	-100			100	nA
				Full	-400			400	
COM On Leakage Cur- rent <sup>(6)</sup>	$I_{COM(ON)}$	$V_{DD} = 4.2V$		25	-200		200		
				Full	-400		400		

**Notes:**

- The algebraic convention, where most negative value is a minimum and most positive is a maximum, is used in this data sheet.
- Typical values are for DESIGN AID ONLY, not guaranteed or subject to production testing.
- Guaranteed by design.
- $\Delta R_{ON} = R_{ON \text{ max.}} - R_{ON \text{ min.}}$
- Flatness is defined as the difference between the maximum and minimum value of On-Resistance measured.
- Leakage parameters are 100% tested at maximum rated hot temperature and guaranteed by correlation at +25°C.
- Off Isolation =  $20 \log_{10} [ V_{COM} / (V_{NO} \text{ or } V_{NC}) ]$ . See Figure 4.
- Between any two switches. See Figure 5.

**Electrical Specifications - Single +3.3V Supply**

( $V_{DD} = +3.3V \pm 10\%$ ,  $GND = 0V$ ,  $V_{IH} = 1.4V$ ,  $V_{IL} = 0.5V$ )

Parameter	Symbol	Conditions	Temp. (°C)	Min. <sup>(1)</sup>	Typ. <sup>(2)</sup>	Max. <sup>(1)</sup>	Units
<b>Analog Switch</b>							
Analog Signal Range <sup>(3)</sup>	$V_{ANALOG}$		Full	0		$V_{DD}$	V
On Resistance	$R_{ON}$	$V_{DD} = 2.7V$ , $I_{COM} = 100mA$ , $V_{NO}$ or $V_{NC} = +1.5V$	25		0.4	0.45	$\Omega$
			Full			0.6	
On-Resistance Match Between Channels <sup>(4)</sup>	$\Delta R_{ON}$		25			0.08	
			Full			0.09	
On-Resistance Flatness <sup>(5)</sup>	$R_{FLAT(ON)}$	$V_{DD} = 2.7V$ , $I_{COM} = 100mA$ , $V_{NO}$ or $V_{NC} = 0.8V, 2.0V$	25			0.1	
			Full			0.1	
NO or NC Off Leakage Current <sup>(6)</sup>	$I_{NO(OFF)}$ or $I_{NC(OFF)}$	$V_{DD} = 3.3V$ , $V_{COM} = 0V$ , $V_{NO}$ or $V_{NC} = +2.0V$	25	-100		100	nA
			Full	-400		400	
COM On Leakage Current <sup>(6)</sup>	$I_{COM(ON)}$	$V_{DD} = 3.3V$ , $V_{COM} = +2.0V$ , $V_{NO}$ or $V_{NC} = +2.0V$	25	-200		200	
			Full	-400		400	

**Notes:**

1. The algebraic convention, where most negative value is a minimum and most positive is a maximum, is used in this data sheet.
2. Typical values are for DESIGN AID ONLY, not guaranteed or subject to production testing.
3. Guaranteed by design.
4.  $\Delta R_{ON} = R_{ON \text{ max.}} - R_{ON \text{ min.}}$
5. Flatness is defined as the difference between the maximum and minimum value of On-Resistance measured.
6. Leakage parameters are 100% tested at maximum rated hot temperature and guaranteed by correlation at +25°C.
7. Off Isolation =  $20\log_{10} [ V_{COM} / (V_{NO} \text{ or } V_{NC}) ]$ . See Figure 4.
8. Between any two switches. See Figure 5.

### Electrical Specifications - Single +4.2V Supply

( $V_{DD} = +4.2V \pm 5\%$ ,  $GND = 0V$ ,  $V_{IH} = 1.6V$ ,  $V_{IL} = 0.7V$ )

Description	Parameters	Test Conditions	Temp (°C)	Min. <sup>(1)</sup>	Typ. <sup>(2)</sup>	Max. <sup>(1)</sup>	Units	
<b>Logic Input</b>								
Input High Voltage	$V_{IH}$	Guaranteed logic High Level	Full	1.6			V	
Input Low Voltage	$V_{IL}$	Guaranteed logic Low Level				0.7		
Input Current with Voltage High	$I_{INH}$	$V_{IN} = 1.4V$ , all others = 0.5V		-1		1	$\mu A$	
Input Current with Voltage Low	$I_{INL}$	$V_{IN} = 0.5V$ , all other = 1.4V		-1		1		
<b>Dynamic</b>								
Turn-On Time	$t_{ON}$	$V_{DD} = 4.2V$ , $V_{NO}$ or $V_{NC} = 2.0V$ , Figure 1	25			20	ns	
			Full			25		
Turn-Off Time	$t_{OFF}$		25			12		
			Full			15		
Break-Before-Make	$t_{BBM}$	$V_{NO}$ or $V_{NC} = 1.5V$ , $R_L = 50\Omega$ , $C_L = 35pF$ , See Figure 8	25	1	12			
			Full	1				
Charge Injection <sup>(3)</sup>	Q		$C_L = 1nF$ , $V_{GEN} = 0V$ , $R_{GEN} = 0\Omega$ , Figure 2	25		100		$pC$
Off Isolation <sup>(7)</sup>	$O_{IRR}$	$R_L = 50\Omega$ , $f = 100kHz$ , Figure 3				-27		dB
Cross Talk <sup>(8)</sup>	$X_{TALK}$	$R_L = 50\Omega$ , $f = 100kHz$ , Figure 4				-41		
NC or NO Capacitance	$C_{(OFF)}$	$f = 1MHz$ , Figure 5			56		$pF$	
COM Off Capacitance	$C_{COM(OFF)}$				56			
COM On Capacitance	$C_{COM(ON)}$		$f = 1MHz$ , Figure 6			160		
<b>Supply</b>								
Power-Supply Range	$V_{DD}$		Full	1.5		3.6	V	
Positive Supply Current	$I_{CC}$	$V_{DD} = 3.6V$ , $V_{IN} = 0V$ or $V_{DD}$	25			0.3	$\mu A$	

**Notes:**

1. The algebraic convention, where most negative value is a minimum and most positive is a maximum, is used in this data sheet.
2. Typical values are for DESIGN AID ONLY, not guaranteed or subject to production testing.
3. Guaranteed by design.
4.  $\Delta R_{ON} = R_{ON} \text{ max.} - R_{ON} \text{ min.}$
5. Flatness is defined as the difference between the maximum and minimum value of On-Resistance measured.
6. Leakage parameters are 100% tested at maximum rated hot temperature and guaranteed by correlation at +25°C.
7. Off Isolation =  $20\log_{10} [ V_{COM} / (V_{NO} \text{ or } V_{NC}) ]$ . See Figure 4.
8. Between any two switches. See Figure 5.

### Electrical Specifications - Single +3.3V Supply

( $V_{DD} = +3.3V \pm 10\%$ ,  $GND = 0V$ ,  $V_{IH} = 1.4V$ ,  $V_{IL} = 0.5V$ )

Description	Parameters	Test Conditions	Temp (°C)	Min. <sup>(1)</sup>	Typ. <sup>(2)</sup>	Max. <sup>(1)</sup>	Units	
<b>Logic Input</b>								
Input High Voltage	$V_{IH}$	Guaranteed logic High Level	Full	1.4			V	
Input Low Voltage	$V_{IL}$	Guaranteed logic Low Level				0.5		
Input Current with Voltage High	$I_{INH}$	$V_{IN} = 1.4V$ , all others = 0.5V		-1		1	$\mu A$	
Input Current with Voltage Low	$I_{INL}$	$V_{IN} = 0.5V$ , all other = 1.4V		-1		1		
<b>Dynamic</b>								
Turn-On Time	$t_{ON}$	$V_{DD} = 3.3V$ , $V_{NO}$ or $V_{NC} = 2.0V$ , Figure 1	25			20	ns	
			Full			25		
Turn-Off Time	$t_{OFF}$		25			12		
			Full			15		
Break-Before-Make	$t_{BBM}$	$V_{NO}$ or $V_{NC} = 1.5V$ , $R_L = 50\Omega$ , $C_L = 35pF$ , See Figure 8	25	1	12			
			Full	1				
Charge Injection <sup>(3)</sup>	Q		$C_L = 1nF$ , $V_{GEN} = 0V$ , $R_{GEN} = 0\Omega$ , Figure 2	25		100		pC
Off Isolation <sup>(7)</sup>	$O_{IRR}$		$R_L = 50\Omega$ , $f = 100kHz$ , Figure 3			-27		dB
Cross Talk <sup>(8)</sup>	$X_{TALK}$	$R_L = 50\Omega$ , $f = 100kHz$ , Figure 4			-41			
NC or NO Capacitance	$C_{(OFF)}$	$f = 1MHz$ , Figure 5			56		pF	
COM Off Capacitance	$C_{COM(OFF)}$				56			
COM On Capacitance	$C_{COM(ON)}$		$f = 1MHz$ , Figure 6			160		
<b>Supply</b>								
Power-Supply Range	$V_{DD}$		Full	1.5		3.6	V	
Positive Supply Current	$I_{CC}$	$V_{DD} = 3.6V$ , $V_{IN} = 0V$ or $V_{DD}$	25			0.3	$\mu A$	

**Notes:**

1. The algebraic convention, where most negative value is a minimum and most positive is a maximum, is used in this data sheet.
2. Typical values are for DESIGN AID ONLY, not guaranteed or subject to production testing.
3. Guaranteed by design.
4.  $\Delta R_{ON} = R_{ON} \text{ max.} - R_{ON} \text{ min.}$
5. Flatness is defined as the difference between the maximum and minimum value of On-Resistance measured.
6. Leakage parameters are 100% tested at maximum rated hot temperature and guaranteed by correlation at +25°C.
7. Off Isolation =  $20\log_{10} [ V_{COM} / (V_{NO} \text{ or } V_{NC}) ]$ . See Figure 4.
8. Between any two switches. See Figure 5.

### Electrical Specifications - Single +2.5V Supply

( $V_{DD} = +2.5V \pm 10\%$ ,  $GND = 0V$ ,  $V_{IH} = 1.4V$ ,  $V_{IL} = 0.5V$ )

Description	Parameters	Test Conditions	Temp.(°C)	Min. <sup>(1)</sup>	Typ. <sup>(2)</sup>	Max. <sup>(1)</sup>	Units
<b>Analog Switch</b>							
Analog Signal Range <sup>(3)</sup>	$V_{ANALOG}$			0		$V_{DD}$	V
On Resistance	$R_{ON}$	$V_{DD} = 2.5V$ , $I_{COM} = 80mA$ , $V_{NO}$ or $V_{NC} = 1.8V$	25			0.5	Ω
			Full			0.55	
On-Resistance Match Between Channels <sup>(4)</sup>	$\Delta R_{ON}$	25			0.09		
		Full			0.09		
On-Resistance Flatness <sup>(5)</sup>	$R_{FLAT(ON)}$	$V_{DD} = 2.5V$ , $I_{COM} = 80mA$ , $V_{NO}$ or $V_{NC} = 0.8V$ 1.8V	25			0.1	
			Full			0.1	
<b>Dynamic</b>							
Turn-On Time	$t_{ON}$	$V_{DD} = 2.5V$ , $V_{NO}$ or $V_{NC} = 1.8V$ , Figure 1	25			20	ns
			Full			30	
Turn-Off Time	$t_{OFF}$	25			12		
		Full			15		
Break-Before-Make	$t_{BBM}$	$V_{NO}$ or $V_{NC} = 1.5V$ , $R_L = 50\Omega$ , $C_L = 35pF$ , See Figure 8	25	1	15		
Charge Injection <sup>(3)</sup>	Q	$C_L = 1nF$ , $V_{GEN} = 0V$ , $R_{GEN} = 0V$ , Figure 2	25		60		pC
<b>Logic Input</b>							
Input HIGH Voltage	$V_{IH}$	Guaranteed logic high level	Full	1.4			V
Input LOW Voltage	$V_{IL}$	Guaranteed logic Low level	Full			0.5	
Input HIGH Current	$I_{INH}$	$V_{IN} = 1.4V$ , all others = 0.5V	Full	-1		1	μA
Input HIGH Current	$I_{INL}$	$V_{IN} = 0.5V$ , all others = 1.4V	Full	-1		1	

**Notes:**

1. The algebraic convention, where most negative value is a minimum and most positive is a maximum, is used in this data sheet.
2. Typical values are for DESIGN AID ONLY, not guaranteed or subject to production testing.
3. Guaranteed by design.
4.  $\Delta R_{ON} = R_{ON} \text{ max.} - R_{ON} \text{ min.}$
5. Flatness is defined as the difference between the maximum and minimum value of On-Resistance measured.

### Electrical Specifications - Single +1.8V Supply

( $V_{DD} = +1.8V \pm 10\%$ ,  $GND = 0V$ ,  $V_{INH} = 1.4V$ ,  $V_{INL} = 0.5V$ )

Description	Parameters	Test Conditions	Temp.(°C)	Min. <sup>(1)</sup>	Typ. <sup>(2)</sup>	Max. <sup>(1)</sup>	Units	
<b>Analog Switch</b>								
Analog Signal Range <sup>(3)</sup>	$V_{ANALOG}$			0		$V_{DD}$	V	
On-Resistance	$R_{ON}$	$V_{DD} = 1.8V$ , $I_{COM} = 60mA$ , $V_{NO}$ or $V_{NC} = 1.5V$	25			0.55	Ω	
			Full			0.7		
On-Resistance Match Between Channels <sup>(4)</sup>	$\Delta R_{ON}$		25			0.03		
			Full			0.03		
On-Resistance Flatness <sup>(5)</sup>	$R_{FLAT(ON)}$	25			0.9			
		Full			1.1			
<b>Dynamic</b>								
Turn-On Time	$t_{ON}$	$V_{DD} = 1.8V$ , $V_{NO}$ or $V_{NC} = 1.5V$ , Figure 1	25			40	ns	
			Full			50		
Turn-Off Time	$t_{OFF}$		25			12		
			Full			15		
Break-Before-Make	$t_{BBM}$		$V_{NO}$ or $V_{NC} = 1.5V$ , $R_L = 50\Omega$ , $C_L = 35pF$ , See Figure 8	25	1	30		
Charge Injection <sup>(3)</sup>	Q		$C_L = 1nF$ , $V_{GEN} = 0V$ , $R_{GEN} = 0V$ , Figure 2	25		40		
<b>Logic Input</b>								
Input HIGH Voltage	$V_{IH}$	Guaranteed logic high level	Full	1.4			V	
Input LOW Voltage	$V_{IL}$	Guaranteed logic Low level	Full			0.5		
Input HIGH Current	$I_{INH}$	$V_{IN} = 1.4V$ , all others = 0.5V	Full	-1		1	μA	
Input HIGH Current	$I_{INL}$	$V_{IN} = 0.5V$ , all others =1.4V	Full	-1		1		

**Notes:**

1. The algebraic convention, where most negative value is a minimum and most positive is a maximum, is used in this data sheet.
2. Typical values are for DESIGN AID ONLY, not guaranteed or subject to production testing.
3. Guaranteed by design.
4.  $\Delta R_{ON} = R_{ON} \text{ max.} - R_{ON} \text{ min.}$
5. Flatness is defined as the difference between the maximum and minimum value of On-Resistance measured.

### Test Circuits/Timing Diagrams

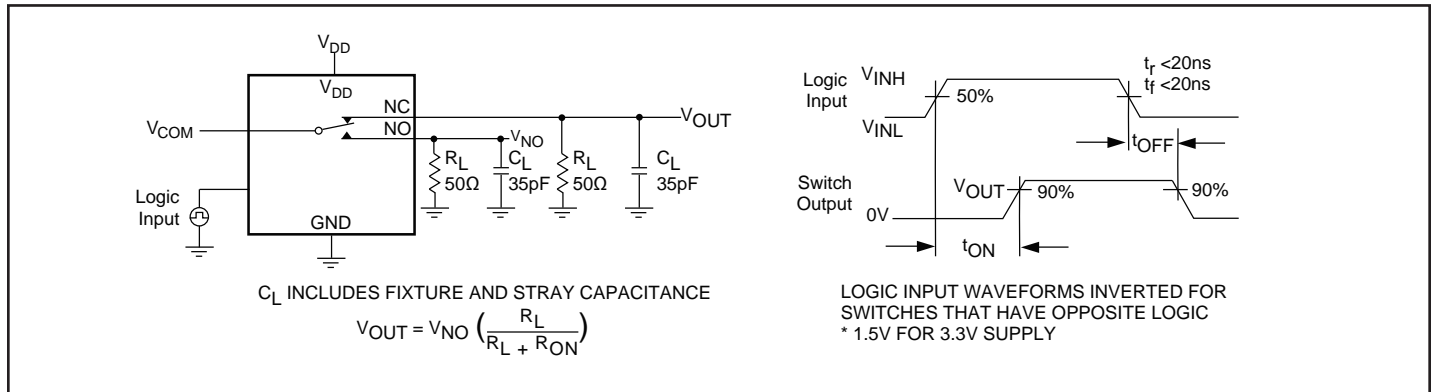

Figure 1. Switching Time

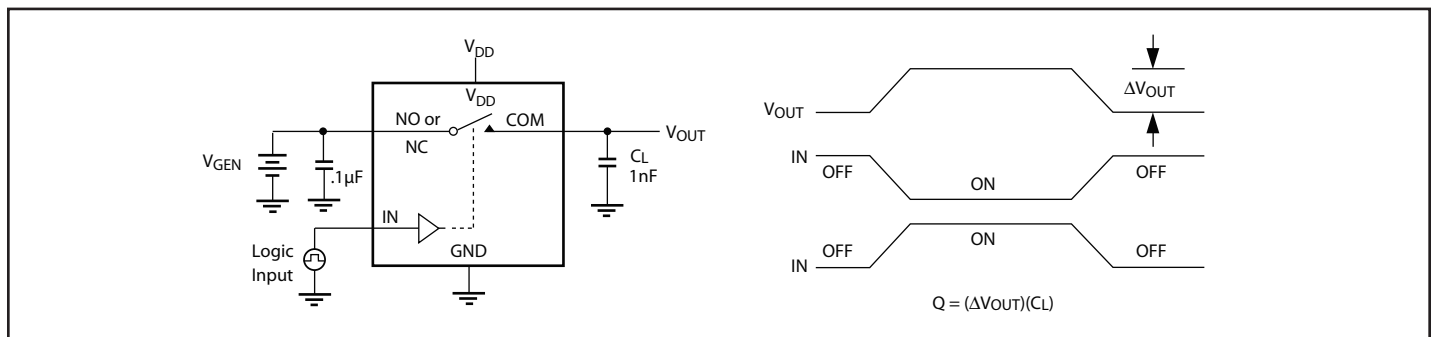

Figure 2. Charge Injection

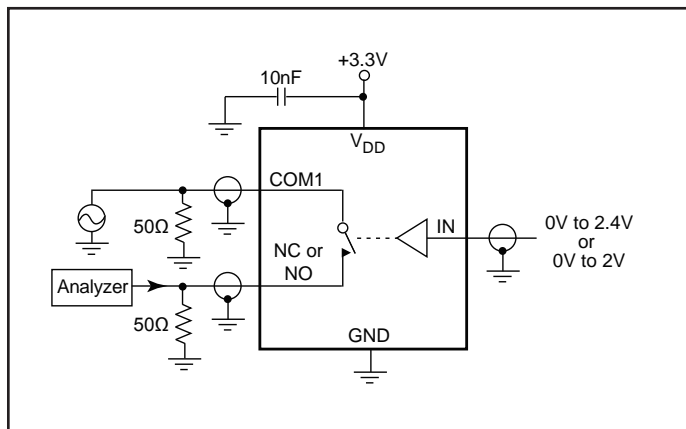

Figure 3. Off Isolation

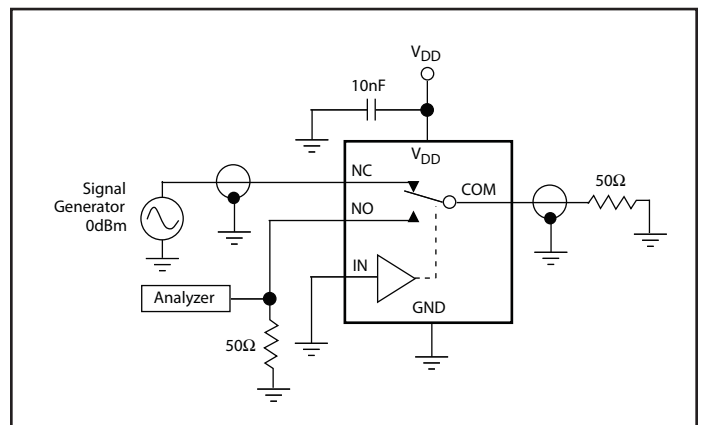

Figure 4. Crosstalk

Test Circuits/Timing Diagrams (continued)

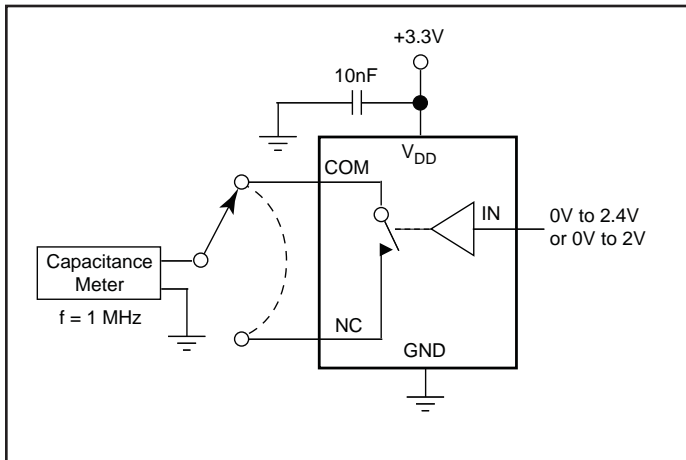

Figure 5. Channel-Off Capacitance

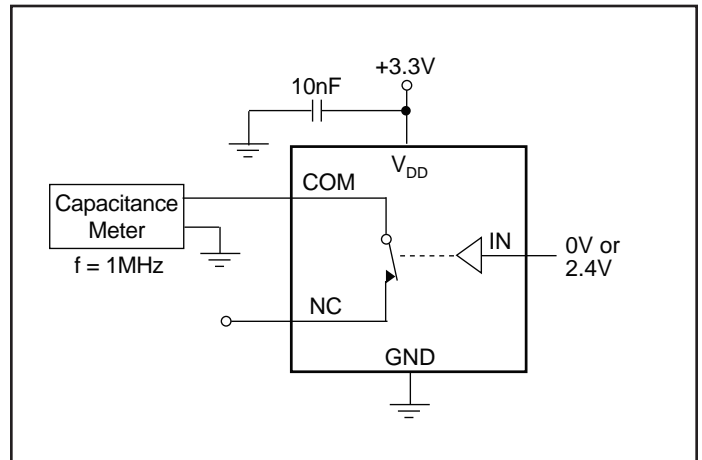

Figure 6. Channel-On Capacitance

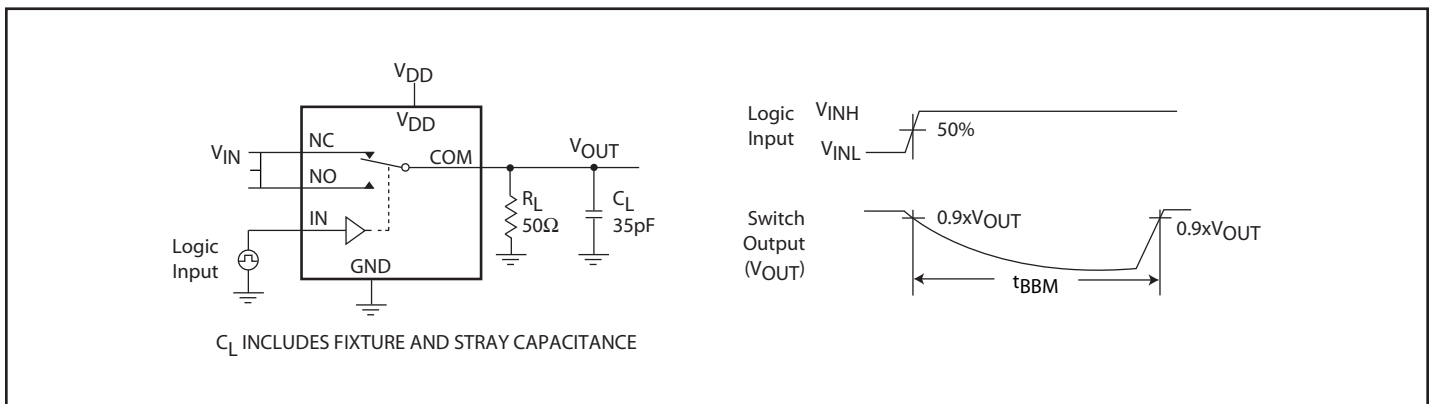
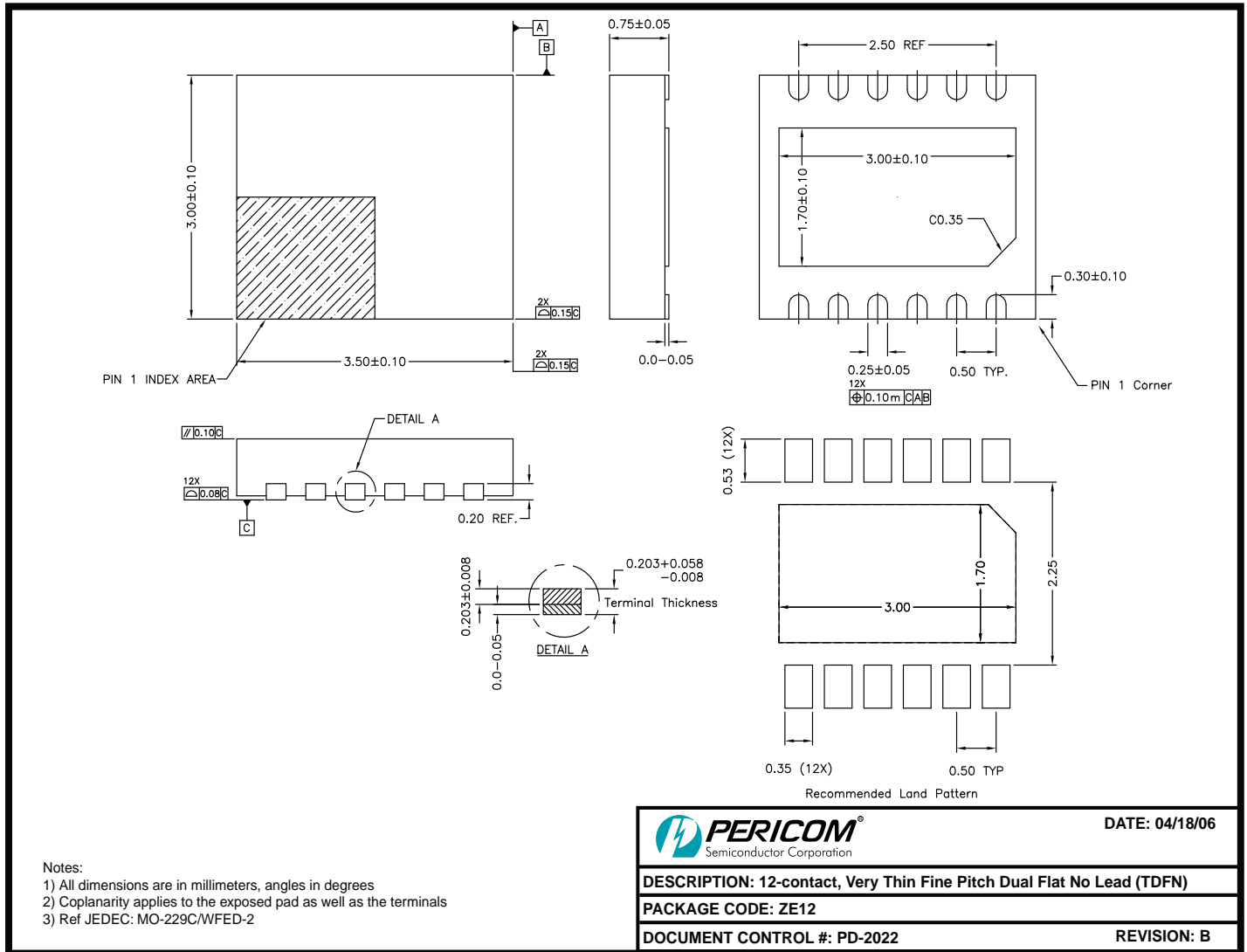

Figure 8. Break Before Make Diagram

**Packaging Mechanical: 12-Contact TDFN (ZE)**

06-0360

**Note:**

- For latest package info, please check: <http://www.pericom.com/products/packaging/mechanicals.php>

**Ordering Information**



Ordering Code	Package Code	Package Description	Top Mark
PI3A3160ZEEX	ZE	Pb-free & Green, 12-contact TDFN	YI

**Notes:**

1. Thermal characteristics can be found on the company web site at [www.pericom.com/packaging/](http://www.pericom.com/packaging/)
2. X = Tape/Reel
3. Number of transistors = TBD

## Looking for pricing, stock, or lifecycle information?

Click below to explore more details on WIN SOURCE:

-  [View PI3A3160ZEEX on WIN SOURCE](#)
-  [Diodes Incorporated Information](#)

## Optimize Your Supply Chain with WIN SOURCE Solutions

-  Global Sourcing Solution
-  Obsolete Management
-  Cost Control Management
-  Shortage Management
-  Alternative Solution
-  Excess Inventory Management